

Genie®

OPERATOR HANDBOOK

Code 57.0002.3200 - 12/2002

Handler with telescopic boom **GTH-3013 - GTH-3517**

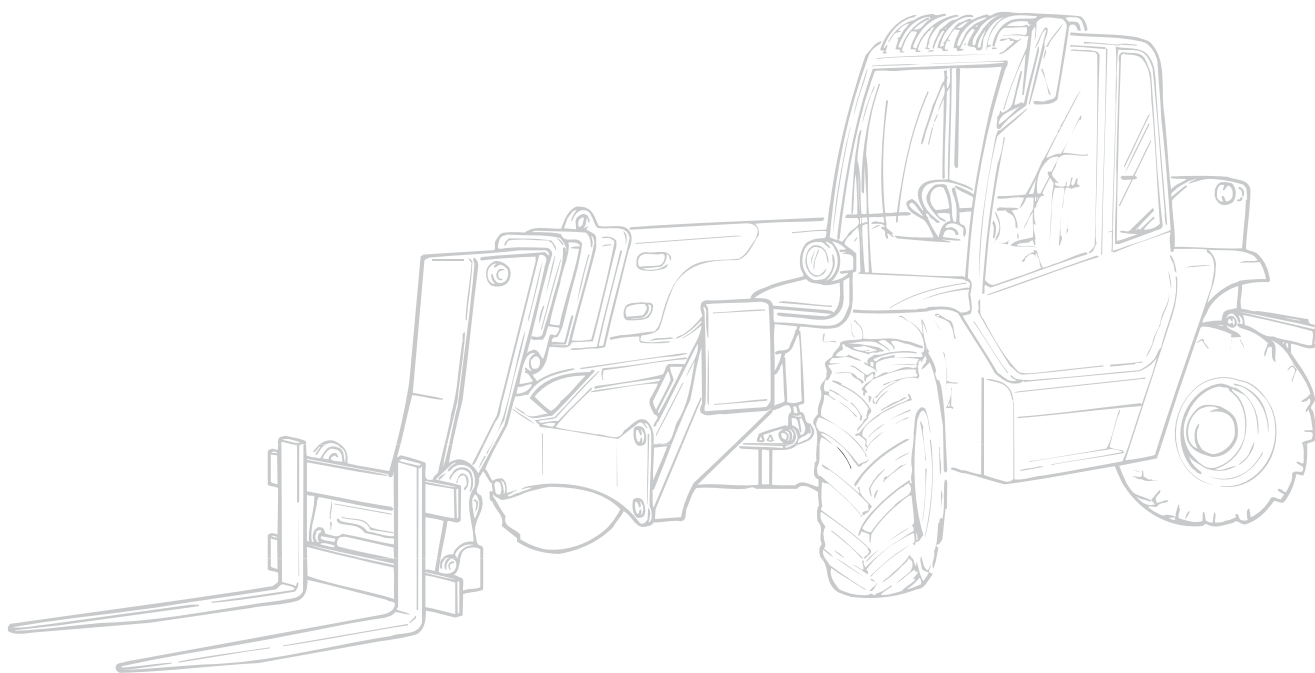

Version

English



**CAUTION: THOROUGHLY READ AND UNDERSTAND THIS HANDBOOK BEFORE OPERATING THE MACHINE
CAUTION: KEEP THIS HANDBOOK IN THE MACHINE AT ALL TIMES**

CLICK HERE TO **DOWNLOAD** THE COMPLETE MANUAL

- Thank you very much for reading the preview of the manual.
- You can download the complete manual from: www.heydownloads.com by clicking the link below



- Please note: If there is no response to CLICKING the link, please download this PDF first and then click on it.

CLICK HERE TO **DOWNLOAD** THE COMPLETE MANUAL

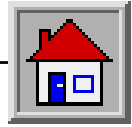

GENERAL INFORMATION

■ A-1.2 LABELS AND WARNING PLATES APPLIED ON THE MACHINE

This paragraph lists the labels and warning plates normally applied on standard machines or on special attachments coupled to the machine.

IMPORTANT

*The familiarisation with these labels is never a waste of time.
 Make sure they are easy to read. For this purpose, clean them or replace those that become unreadable (either graphic or text).
 To clean labels, use of a soft cloth, water and soap.
 Never use solvents, petrol, etc.
 When a label is applied on a part to be replaced, make sure that the replaced part is already labelled as required or apply a new label.*



Description:
 red/white label “Keep out of the working range of the machine”.

Meaning:
 when the machine is running, entering the working range of the machine is prohibited.

Location:
 on the telescopic boom, both on the right and on the left.



Description:
 label with white background “Keep out of the working range of the machine”.

Meaning:
 when the machine is running, entering the working range of the machine is prohibited.

Location:
 one on the right side in the casing of the engine compartment
 one on the left side on the fuel tank

Description:
 label with transparent background explaining the use of the control lever.

Meaning:
 through the use of special symbols, this label explains all possible functions and motions of the control lever and the built-in pushbuttons.

Location:
 in the cab, on the windscreen, to the right of the driving place.

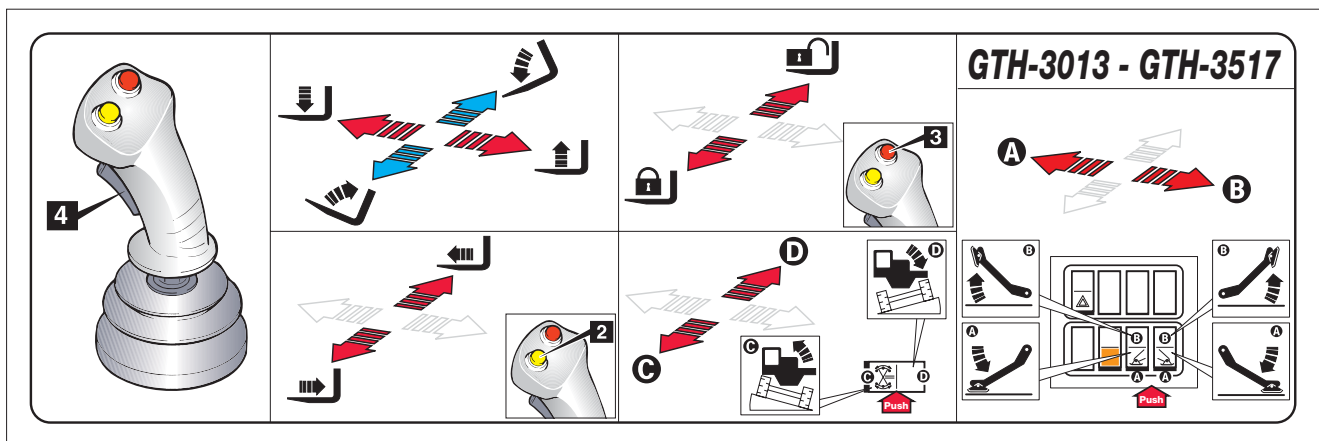

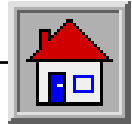

GENERAL INFORMATION

■ **A-3.4 APPLICABLE STANDARDS**

For the operator’s safety, the following standards were obeyed during the risk assessment of the handler fitted with telescopic boom:

Directive	Title
98/37/CE	Machinery Directive
89/336/CEE	Electromagnetic compatibility
73/23/CEE	Low Voltage
2000/14/CE	Environment Acoustic Emissions
Standard	Title
EN 1459:1988	Harmonised standard. Safety of industrial trucks - Self- propelled variable reach trucks.
EN 281:1988	Self-propelled industrial trucks sit- down rider-controlled. Rules for the construction and layout of pedals.
EN 292-1:1991	Safety of machinery. Basic concepts, general principles for design. Basic terminology, methodology.
EN 292-2:1991	Safety of machinery. Basic concepts, principles for design. Technical principles and specification.
EN 1175-2:1998	Electrical requirements - General requirements of internal combustion engine powered trucks
prEN ISO 13564:1996	Test method for measuring visibility from self-propelled trucks.
ISO 2330:1995	Fork-lift trucks - Fork arms - Technical characteristics and testing.
ISO/DIS 3287	Powered industrial trucks. Pictorial signs. Control symbols.
ISO 3449:1992	Earth-moving machinery - Falling-object protective structures - Laboratory tests and performance requirements.
EN 13510: 2002	Earth-moving machinery - Roll-over protective structures - Laboratory tests and performance requirements.
ISO 3776:1989	Tractors for agriculture - Seat belt anchorages.
ISO 3795:1989	Road vehicles, tractors and machinery for agriculture and forestry - Determination of burning behaviour of interior materials.

ISO 5053:1987	Powered industrial trucks - Terminology.
ISO 6055:1997	High-lift rider trucks - Overhead guards - Specification and testing.
ISO 6292:1996	Powered industrial trucks and tractors - Brake performance and component strength.
ISO 9533:1989	Earth-moving machinery - Machine-mounted forward and reverse audible warning alarm - Sound test method.
prEN 13059:1997	Safety of industrial trucks - Test methods for measuring vibration
EN 50081-1: 1997	Electromagnetic compatibility – Generic requirements on emissions - Part 1
EN 50082-1: 1997	Electromagnetic compatibility – Generic requirements on immunity - Part 1
EN 60204-1:1998	Safety of machinery - Electrical equipment of machines - Part 1

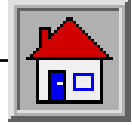

SAFETY

Section B

SAFETY

TABLE OF CONTENTS

B-1	GENERAL REMARKS	B-2
B-2	PREREQUISITES OF THE PERSONNEL IN CHARGE	B-2
B-2.1	Prerequisites of the machine operators	B-2
B-2.2	Prerequisites of the servicemen	B-3
B-2.3	Working clothes	B-3
B-2.4	Personal protective equipment	B-3
B-3	SAFETY PRECAUTIONS	B-4
B-3.1	Job site	B-4
B-3.2	Getting ready to work	B-5
B-3.3	During work or maintenance	B-5
B-4	Safety devices	B-7

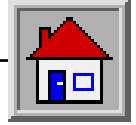

OPERATING INSTRUCTIONS

C-2 ENTERING THE MACHINE

C-2.1 ENTERING THE CAB



CAUTION

Always make sure that your hands and shoe soles are clean and dry before getting into the driving cab. Always face the machine when entering and leaving it and hold to the suitable handles.

The handler cab is equipped with an access door on the left-hand side.

Door opening from outside:

- Insert the key and release lock **1**.
- Open the door using the built-in handle.

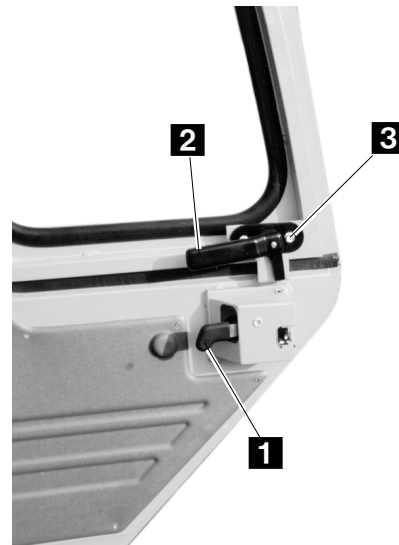
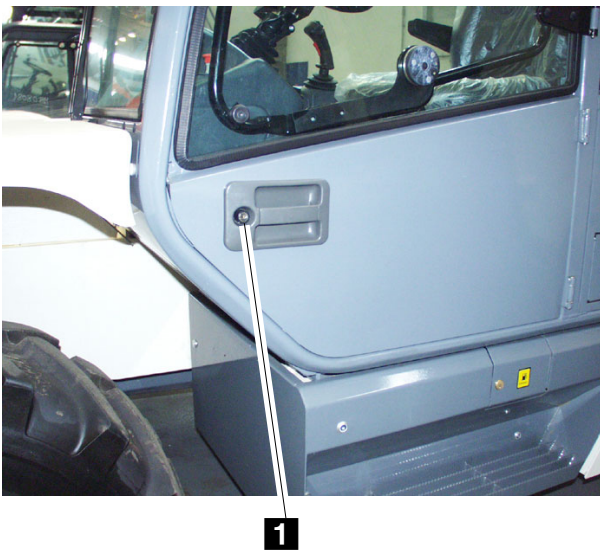

CAUTION

The upper section of the door must be secured to the rear part of the driving cab or latched to the lower section of the same door.

■ C-2.1.1 Leaving the cab in an emergency

In an emergency, use the rear window of the cab as safety exit-way.

This window has special locking handles with plastic pins easy to pull out when you need to fully open the glass.

Door closing from inside:

- Pull the door with force: it locks automatically.

Door opening from inside:

- Lift lever **1** and release the lock to open the door completely.
- Hold button **3** pressed down and rotate handle **2** to open and lock the upper door section against the catch located outside the driving cab.

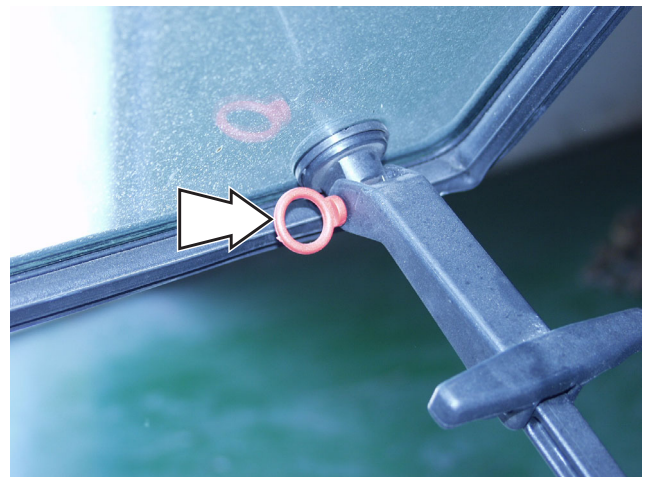

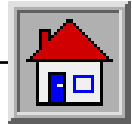

OPERATING INSTRUCTIONS

C-3.3 INSTRUMENTS AND LIGHT INDICATORS

C-3.3.1 Instruments

36 Engine coolant temperature indicator
Signals the engine coolant temperature



37 Fuel gauge
Signals the fuel level within the tank.



38 Hydraulic oil temperature indicator
Signals the temperature of the hydraulic oil within the reservoir.



39 Hour-meter
Signals the total operating hours of the machine.



C-3.3.2 Light indicators

16 Fuel reserve indicator



This light comes on to signal a limited fuel autonomy of the machine. When the indicator comes on, the fuel reserve is about 10 litres.

23 Indicator light - hydraulic oil filter clogged



When this lamp sets to on, immediately change the oil filter on the return line to the tank.

24 Indicator light - air filter clogged



When this lamp sets to on, clean or change the filter elements.

25 Indicator light - low battery charge



Signals a low charge by the alternator

26 Indicator light - low brake pressure



It lights when the pressure of the braking circuit is too low for a correct functioning

27 Indicator light - low engine oil pressure



It lights when the engine oil pressure is too low.

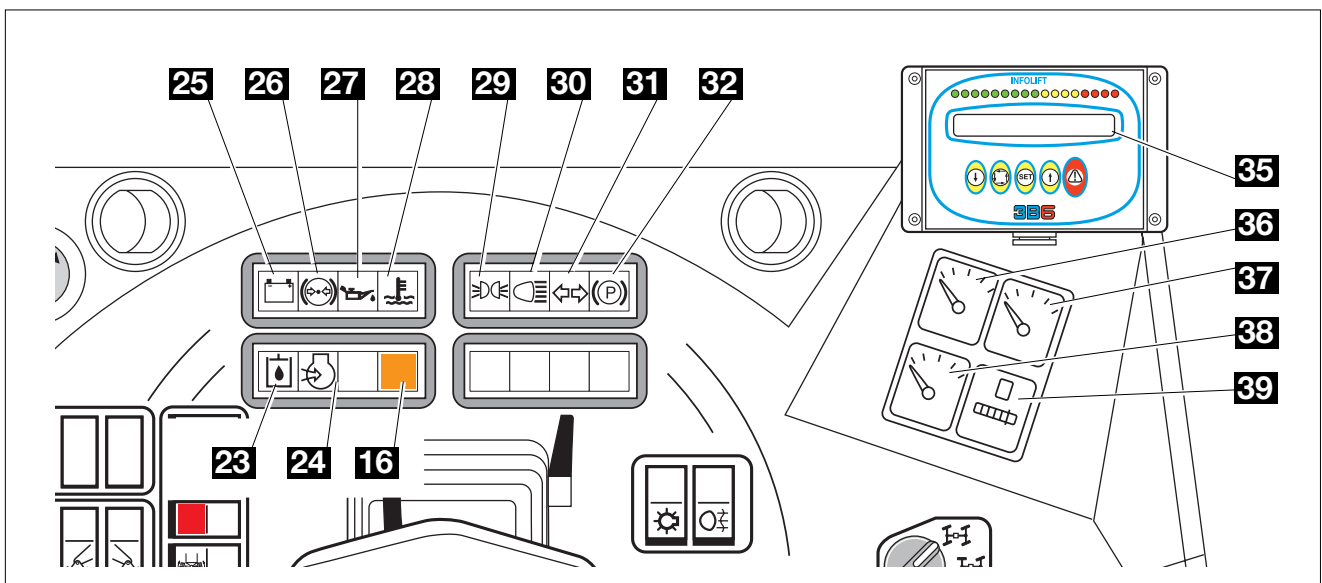



OPERATING INSTRUCTIONS

C-3.6 OUTRIGGER CONTROL



Before lowering the outriggers, make sure that nobody is within the working range of the machine.

To operate the outriggers:

- Shift the control lever to central position and press button **4**
- Press button **15** and hold it down to enable the motion of the right outrigger:
select **1** to lower the outrigger
select **2** to raise the outrigger
- Press button **13** and hold it down to enable the motion of the left outrigger:
select **1** to lower the outrigger
select **2** to raise the outrigger
- Shift the control lever to the position selected by means of the enabling pushbutton:
select **A** to lower the outrigger
select **B** to raise the outrigger

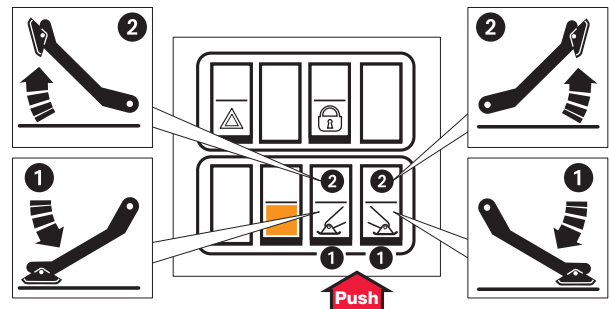
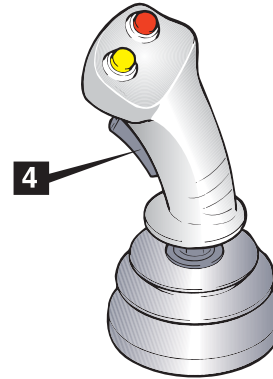
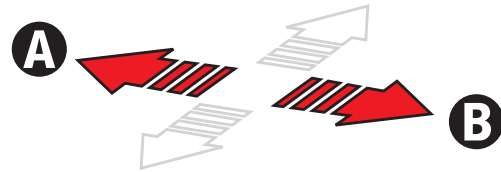

IMPORTANT

In an alarm condition (red stability LED indicator ON) or when the boom is raised beyond the horizontal position, the function-keys 13 and 15 are not enabled.

IMPORTANT

If the command is not executed correctly, e.g. button pressed to the up-position and lever shifted to the down-position, no movement will be operated.

CLICK HERE TO **DOWNLOAD** THE COMPLETE MANUAL

- Thank you very much for reading the preview of the manual.
- You can download the complete manual from: www.heydownloads.com by clicking the link below



- Please note: If there is no response to CLICKING the link, please download this PDF first and then click on it.

CLICK HERE TO **DOWNLOAD** THE COMPLETE MANUAL

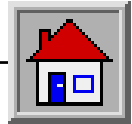

OPERATING INSTRUCTIONS

SWITCHING ON THE MACHINE

Starting the machine the system automatically switches on and, for a few seconds, the display shows the machine model and the software version (dd.mm.yy= software date of development)

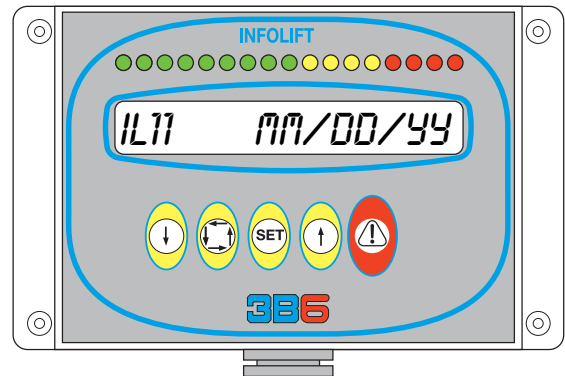

About 10 seconds later, the message **PLEASE CONFIRM** starts flashing on the display:

- Press **SET**
- With key **D** select the attachment installed among those available:

FORCHE	FORK
NAVICELLA	BASKET
VERRICELLO	WINCH
FALCONE	JIB
- The message **PLEASE CONFIRM** shows up
- Confirm the selection pressing the **SET** key

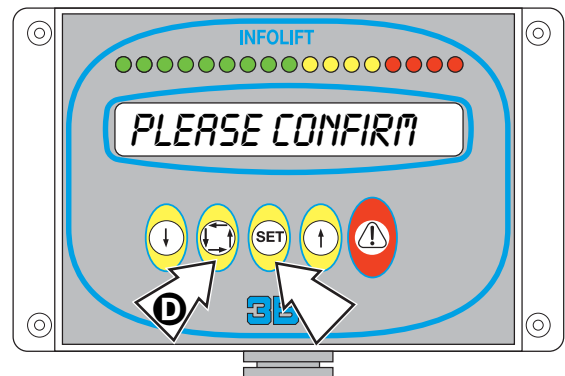

The machine is ready to work.



When the attachment is replaced, it is necessary to set the new attachment on the control panel by hand and to select the load chart related to this new attachment (fforks, basket, winch or jib). During the programming phase, the system is not activated.



Once set, the attachment remains activated even if the machine is stopped and until a new manual setting is done. However, the attachment must always be confirmed pressing the SET key every time the machine is started up.

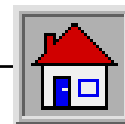

MAINTENANCE

Section **D**

MAINTENANCE

TABLE OF CONTENTS

D-1	LUBRICANTS - HEALTH AND SAFETY PRECAUTIONS	D-2
D-2	ORDINARY MAINTENANCE	D-3
D-3	MAINTENANCE INTERVENTIONS	D-5
D-3.1	Disconnecting the battery	D-6
D-3.2	Access to the engine compartment	D-6
D-3.3	Greasing	D-7
D-3.4	Tyres and wheels	D-8
D-3.5	Brakes	D-8
D-3.6	Engine air filter	D-9
D-3.7	Engine cooling system	D-10
D-3.8	Checking the oil level in the tank	D-11
D-3.9	Changing the canisters of the oil filter in the injection line	D-12
D-3.9.1	Transmission oil filter	D-12
D-3.9.2	Auxiliary circuit oil filter	D-13
D-3.10	Oil level in the differential gears	D-13
D-3.11	Oil level in the (front/rear) wheel reduction gears	D-14
D-3.12	Oil level in the gearbox	D-14
D-3.13	Shafting alignment	D-15
D-3.14	Adjusting the sensor distance	D-16
D-3.15	Adjusting the sliding pads of the boom sections	D-17
D-3.16	Re-sequencing the telescopic boom	D-18
D-3.16.1	Re-tensioning the telescopic boom chains	D-18
D-3.17	Checking the safety devices	D-19
D-4	ELECTRICAL SYSTEM	D-23
D-4.1	Battery	D-23
D-4.2	Fuses and relays	D-24
D-4.3	12V DC lamps	D-26
D-5	REFUELLING	D-27
D-5.1	Refuelling	D-27
D-5.2	Product specifications	D-27
D-5.2.1	Engine oil	D-27
D-5.2.2	Lubrication oils and relevant filtering elements	D-27
D-5.2.3	Fuel	D-28
D-5.2.4	Grease	D-28
D-5.2.5	Engine coolant	D-28

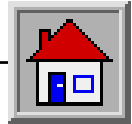

MAINTENANCE

■ D-3.8 CHECKING THE OIL LEVEL IN THE TANK



Fine jets of hydraulic oil under pressure can penetrate the skin. Do not use your fingers, but a piece of cardboard to detect oil leaks.

Check the hydraulic oil level (visually) through the special level **C** fitted into the tank.

When necessary, add new oil through filler **D**.

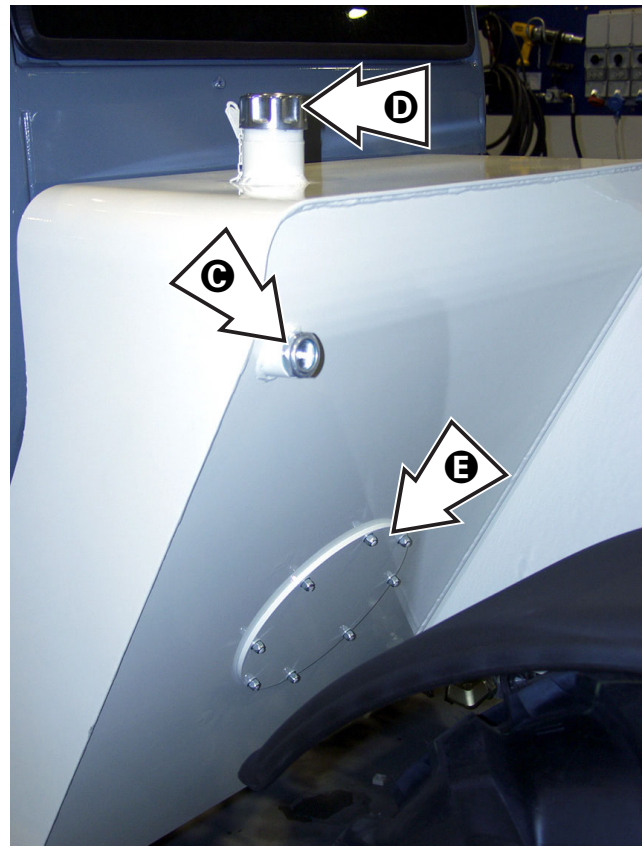

SERVICE INTERVAL

Running-in _____ **Within the first 10 hours**

Ordinary _____ **Every 50 hours**

To change the oil:

- 1 Stop the machine on a level ground and make sure the parking brake is engaged.
- 2 Release the pressure from the hydraulic circuit.
- 3 Place a container of suitable size under the drain plug, placed in the lower part of the reservoir, and collect any oil leaks.
- 4 Remove the drain plug and allow oil to flow out into the container.
- 5 Remove the inspection cover of tank **E**.
- 6 Carefully wash the tank with Diesel oil and blow a jet of compressed air.
- 7 Refit the drain plug and the inspection cover.
- 8 Add new oil by making sure that it matches the recommended type indicated in paragraph D-5.2.2. until it is level with **C**.



PROTECT THE ENVIRONMENT

The handling and disposing of used oils can be ruled by local or national regulations. Address to authorised centres



SERVICE INTERVAL

Running-in _____ **None**

Ordinary _____ **Every 1000 hours**

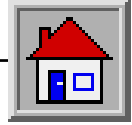
**MAINTENANCE****DANGER**

Do the check of the valves taking all the possible precautionary measures:

- **Wear safety glasses**
- **Wear safety gloves**
- **Wear safety shoes**
- **Wear suitable working clothes**
- **Use guards against leaks of oil at high pressure**
- **Do the check in a free space with barriers all around to keep non-authorized people away**
- **Ensure that the part to be checked is in safe condition and that the action generated does not result in an uncontrolled movement of the machine.**

TO REMOVE THE BLOCK VALVES OR THE CYLINDERS

- **Lower the boom to the ground in a firm way since the removal of the block valve or the cylinder can cause an uncontrolled down-movement.**
- **After refitting the valve or the cylinder, replenish the circuit and eliminate any air before starting working. To eliminate the air from the circuit, move the involved cylinders to end-of-stroke in the two directions (opening/closing. To eliminate the air from the fork balance cylinder, move the boom up and down and tilt the fork plate forwards/back.**

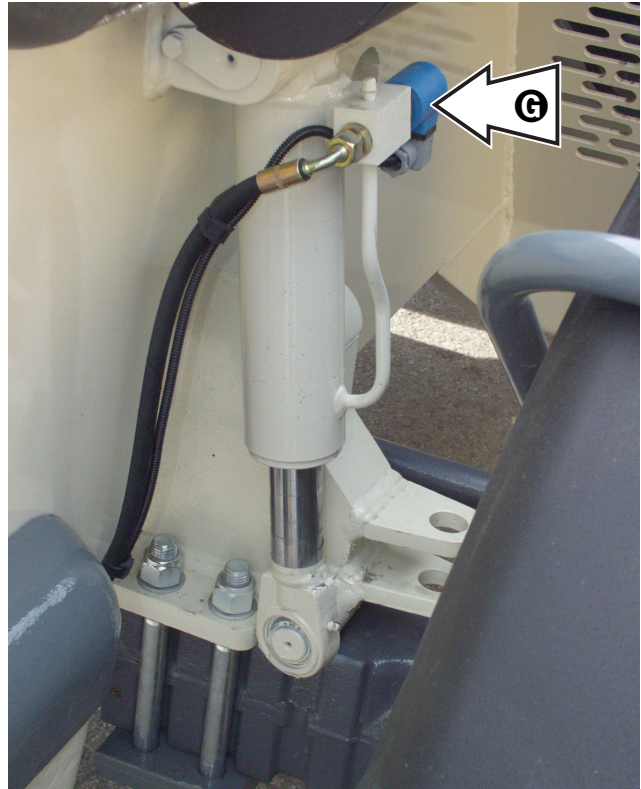
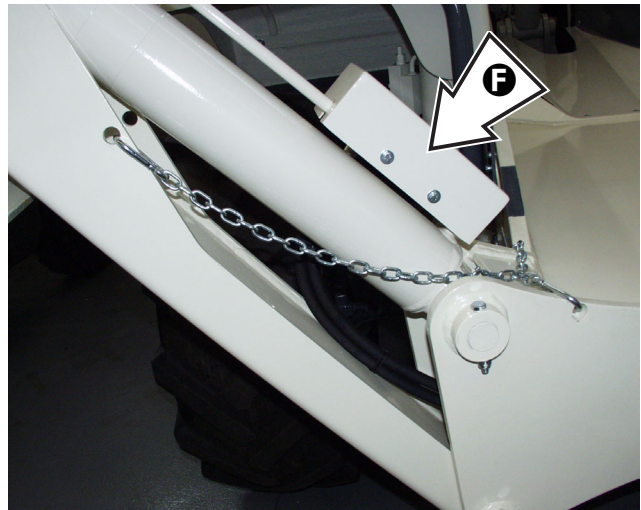

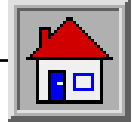

FAULTS AND TROUBLESHOOTING

<p>NO SELECTION OF THE STEERING MODE</p>	<ul style="list-style-type: none"> • “ROAD-CAB-PLATFORM” switch set to “ROAD” 	<ul style="list-style-type: none"> • Select “CAB”
<p>LOW PARKING BRAKE ACTION</p>	<ul style="list-style-type: none"> • Insufficient cable tensioning 	<ul style="list-style-type: none"> • Check and adjust the cable tension by means of the hollow screws • Check and adjust the lead tightening on the cable heads
<p>NO BOOM LOWERING AND EXTENSION, NO HOLDING FRAME PITCHING</p>	<ul style="list-style-type: none"> • Fuse F13 blown 	<ul style="list-style-type: none"> • Replace the fuse
<p>ALARM OF THE OVERLOAD WARNING SYSTEM (red LED ON)</p>	<ul style="list-style-type: none"> • Alarm of the overload warning system 	<ul style="list-style-type: none"> • Retract or raise the boom within safe limits
<p>THE HYDRAULIC OIL THERMOMETER DOES NOT WORK</p>	<ul style="list-style-type: none"> • This is normal, when the outside temperature is low and/or the machine is used for short periods, since the hydraulic oil cannot warm up over 40÷50°C 	
<p>THE OVERLOAD WARNING SYSTEM DOES NOT WORK</p>	<ul style="list-style-type: none"> • Fuse F13 blown 	<ul style="list-style-type: none"> • Check and replace the fuse if necessary
<p>THE BOOM DOES NOT MOVE</p>	<ul style="list-style-type: none"> • Fuse F17 blown • “ROAD-CAB-PLATFORM” switch set to “ROAD” 	<ul style="list-style-type: none"> • Check and replace the fuse if necessary • Select “CAB”

ATTENTION

In case of faults not listed in this chapter, address to the GENIE Technical Assistance, your nearest authorised workshop or dealer.

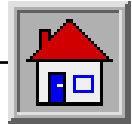

OPTIONAL ATTACHMENTS

■ **F-1.8 MAN-PLATFORM**

■ **F-1.9 ROBOT 5000 / 8000**

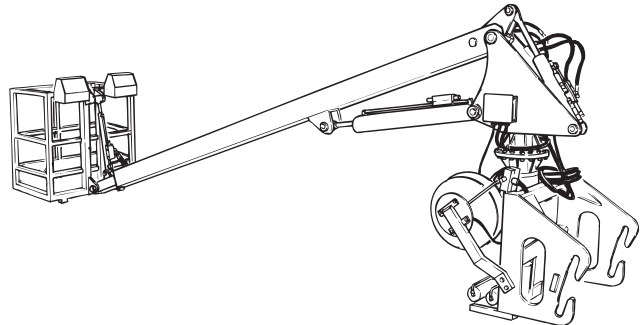
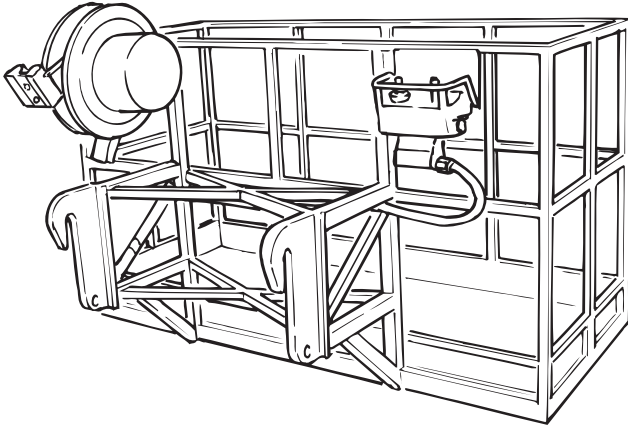

Application and codes

<i>Platform model</i>	GTH	
	3013	3517
2P-200 F	59.1102.8000	59.1102.8000
2P-200 RNE	59.1102.9000	59.1102.9000
2P-200 REM 4400	59.1103.0000	59.1103.0000
3P-1000 RNE	59.1103.1000	59.1103.1000
2P-800 REM 5500	59.1103.2000	59.1103.2000

For the use of this attachment, read the specific manual supplied - code: 57.0300.8200

Application and codes

ROBOT	GTH	
	3013	3517
mod. 5000		
mod. 8000		

For the use of this attachment, read the specific manual supplied - code: 57.0300.7200

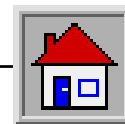
**TABLES AND DOCUMENTS ENCLOSED**

Ref.	Description
78	JOYSTICK CONNECTOR
79	17 m BOOM RELAY S.V
80	17 m BOOM RELAY S.V
81	SENSOR - 17 m BOOM
82	ROAD SAFETY SWITCH
83	SOLENOID VALVE - ATTACHMENT RELEASED
84	SOLENOID VALVE - ATTACHMENT COUPLED
85	SOLENOID VALVE - FIFTH ELEMENT
86	SOLENOID VALVE - FIFTH ELEMENT
87	SWITCH - AXLE LEVELLING
88	SOLENOID VALVE - BOOM RAISED
89	SOLENOID VALVE - BOOM LOWERED
90	SOLENOID VALVE - BOOM EXTENSION
91	SOLENOID VALVE - BOOM RETRACTION
92	SOLENOID VALVE - FORK PITCHING FORWARD
93	SOLENOID VALVE - FORK PITCHING BACK
94	SWITCH - LEFT STABILIZERS UP/DOWN
95	SWITCH - RIGHT STABILIZERS UP/DOWN
96	BACK-UP HORN
97	BEACON
98	SOLENOID VALVE - RIGHT STABILIZER DOWN
99	SOLENOID VALVE - LEFT STABILIZER DOWN
100	OVERLOAD WARNING SYSTEM CONTROL UNIT CUTOUT SWITCH
101	REAR WINDSCREEN WIPER MOTOR
102	SWITCH - EMERGENCY PUMP
103	MUSHROOM-HEAD BUTTON
104	SOLENOID VALVE - ENGINE STOP
105	ENGINE STOP SOLENOID
106	S.V. ENABLING THE EMERGENCY PUMP MOTOR
107	EMERGENCY PUMP
108	RELAY ENABLING THE EMERGENCY PUMP
109	EMERGENCY PUMP PROTECTION FUSE

CLICK HERE TO **DOWNLOAD** THE COMPLETE MANUAL

- Thank you very much for reading the preview of the manual.
- You can download the complete manual from: www.heydownloads.com by clicking the link below



- Please note: If there is no response to CLICKING the link, please download this PDF first and then click on it.

CLICK HERE TO **DOWNLOAD** THE COMPLETE MANUAL