

**GEHL**®

Form No.  
50940322  
Revision B  
July 2018

# Z80 GEN:2

## Compact Excavator

Serial Numbers 00901 and Up



# Operator's Manual

CLICK HERE TO **DOWNLOAD** THE COMPLETE MANUAL

- Thank you very much for reading the preview of the manual.
- You can download the complete manual from: [www.heydownloads.com](http://www.heydownloads.com) by clicking the link below



- Please note: If there is no response to CLICKING the link, please download this PDF first and then click on it.

CLICK HERE TO **DOWNLOAD** THE COMPLETE MANUAL

## **4. Operation License**

---

Before you operate this machine, confirm the licensing requirements that are applicable to the operation of this machine.

Comply with all applicable laws.

Ask your dealer about licensing requirements.

### In case machine trouble occurs

**LED lamps** | The lamp corresponding to the error flashes or lights up.

 **Warning lamp** | If the warning lamp flashes and the buzzer sounds, immediately stop operation and take necessary corrective measures.



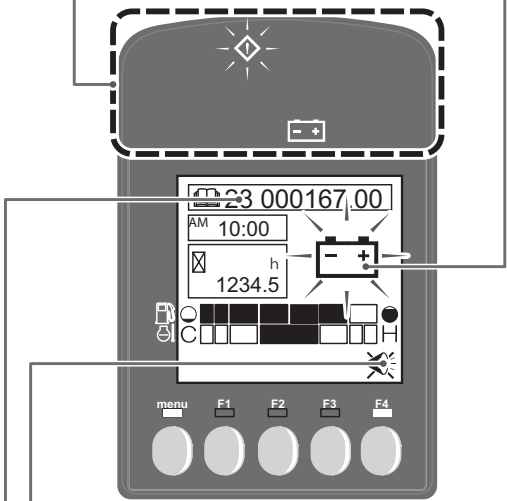





 **Caution lamp** | If the caution lamp flashes, take necessary corrective measures as soon as possible.



**Buzzer stop icon** | When this icon is displayed, pressing the F4 switch will stop the buzzer.

**Error code :** Refer to page 329

**Error icons** | Icons representing the corresponding errors are displayed.

Icon	Error description	Warning/caution lamp	Corrective measures
	Abnormal engine cooling water temperature	Warning lamp flashing	Stop the engine startup process and inspect the engine according to "Troubleshooting" on page 23.
	Abnormal engine oil pressure	Warning lamp flashing	Stop the engine startup process and inspect the engine according to "Troubleshooting" on page 23.
	Insufficient battery charge	Caution lamp flashing	Stop the engine startup process and inspect the engine according to "Troubleshooting" on page 23.
	Clogging of air cleaner	Caution lamp flashing	Stop the engine, and check and clean the air cleaner according to "Checking and cleaning the air cleaner" on page 292 .
	Request for DPF* manual regeneration	Caution lamp flashing	Perform DPF manual regeneration according to "3.24 Handling diesel particulate filter (DPF)" on page 214.
	Insufficient amount of fuel	Caution lamp flashing	Refill the fuel tank
	Other errors	Warning or caution lamp flashing	Check the error code and contact the nearest dealer.
	This does not indicate a failure but indicates that the exhaust gas temperature has risen to high levels due to DPF regeneration. Make sure that there are no persons or flammable objects in the vicinity of the exhaust.		



\*: Diesel particulate filter

### Information display

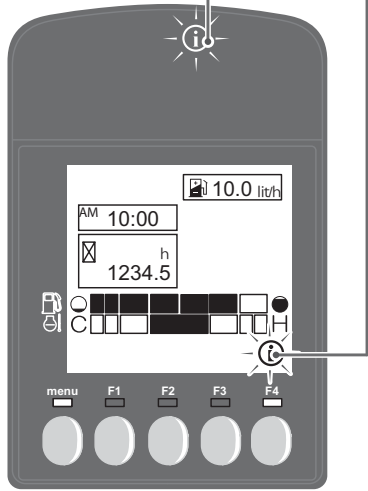
**Information lamp** | This lamp flashes to indicate the existence of information.



**Information icon** | This icon is displayed to indicate the existence of information. Pressing the F4 switch allows checking of information details.

Icon	Description	Reference
	Notice of date and time settings	Procedure for setting the date and time - page 104
	Informs that, based on accumulated hours of operation, maintenance items have reached the maintenance interval. Identify what each of the displayed icons means and perform necessary maintenance according to the instructions given on their corresponding pages.	List of maintenance notices - page 83

# CONTENTS

---

- 1 Introduction ..... 1
- 2 Safety Information ..... 2
- 3 Product Overview..... 3
- 4 Operation License ..... 7
- 5 Ordering Replacement Parts and Service Calls ..... 8
  
- QUICK GUIDE ..... 11**
  
- SAFETY ..... 29**
  - 1 Basic Precautions ..... 30
  - 2 Operating Precautions ..... 36
  - 3 Precautions for Servicing ..... 51
  - 4 Safety Messages (Warning Labels) ..... 60
  
- OPERATION ..... 69**
  - 1 Identification of Important Parts ..... 71
  - 2 Description of Control Devices ..... 73
  - 3 Operating Instructions ..... 139
  - 4 Transportation ..... 223
  - 5 Care and Service in Cold Weather ..... 228
  - 6 Long-term Storage ..... 231
  - 7 Troubleshooting ..... 234
  
- MAINTENANCE ..... 243**
  - 1 Precautions for Servicing ..... 244
  - 2 Basic Servicing Practices ..... 247
  - 3 Consumables ..... 258
  - 4 Fueling, Oiling and Greasing Based on Temperature Range ..... 259
  - 5 Standard Tightening Torque for Bolts and Nuts ..... 260
  - 6 Replacing Essential Parts Periodically ..... 262
  - 7 Maintenance Table ..... 264
  - 8 Procedures for Maintenance ..... 269
  
- SPECIFICATIONS AND DIMENSIONAL DIAGRAMS ..... 313**
  - 1 Specifications and Dimensional Diagrams ..... 314
  
- OPTIONAL PARTS AND ATTACHMENTS ..... 317**
  - 1 General Precautions ..... 318
  
- APPENDIX TABLE ..... 321**

### Inspect around the operator's seat

- Dirt, oil and snow on the floor, levers, handrails or steps are slippery and hazardous. Remove them all completely.
- Keep parts and tools away from the operator's seat as they may damage the control levers or switches or create other hazards.

### Provide adequate ventilation when working in an enclosed area

Engine exhaust fumes are harmful to the human body and their inhalation is extremely hazardous. When starting the engine in an enclosed area, open the windows and doors for ventilation. Also do not idle the engine unnecessarily or leave the engine running while the machine is not in use.

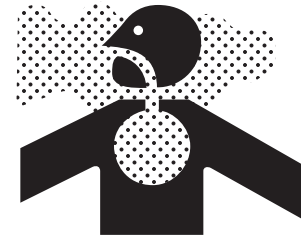

### Keep the cabin window clean

- Keep the surface of the cabin windows and the headlights clean for clear view.
- Make sure that your machine is equipped with headlights and all required working lamps, and that they all work properly.

### Fasten the seatbelt

- For your safety, ROPS (Roll-Over Protective Structure)/OPG (Operator Protective Guards) and a seatbelt have been provided.
- Always fasten the seatbelt across the pelvic region and adjust it snugly before you operate the machine.
- The seatbelt must be replaced if the machine is involved in an accident.
- In addition, the seat and the seat mounting must also be checked by your dealer after an accident has occurred.
- If the seat and the seat mounting are damaged, they must be replaced immediately.

### ROPS/OPG

- Never modify a structural member of the ROPS/OPG.
- If the ROPS/OPG is damaged, replace it immediately to prevent bodily injury. Never repair or modify it. Ask your dealer for replacing it.

## 2.4 Precautions for the battery

### ⚠ DANGER

#### Be careful in handling the battery

- The battery electrolyte contains dilute sulfuric acid, which can severely burn the eyes or skin. Always wear safety goggles and protective clothing when servicing the battery. If contact with the eyes or skin should occur, flush with a large amount of water and obtain prompt medical treatment.
- Because flammable hydrogen gas is produced by the battery, ignition and explosion may occur. Keep flames and sparks away from the battery.
- Do not use or charge the battery if the battery electrolyte level is below the lower limit. Doing so may cause the battery to explode. Always check the battery electrolyte level before starting the engine. If the electrolyte level is low, add distilled water to the upper limit.
- If you swallow battery electrolyte by mistake, drink a large amount of water, milk, or fresh eggs, and obtain medical treatment immediately.
- Before checking or handling the battery, be sure to stop the engine and turn the starter switch to the "OFF" position. Never disconnect the battery cable during engine operation.
- Be careful not to cause a short circuit by placing a tool across the terminals of the battery.
- If a terminal connection is loose, sparks may be generated due to contact failure, causing possible ignition and explosion. Be sure to connect the terminals securely.
- Do not use the machine with the battery which is short of battery electrolyte. The shortage of battery electrolyte not only will reduce the life of the battery but also could cause an explosion.



000297-01X00

**Be careful when servicing systems under high temperature and high pressure**

The engine coolant and each lube oil system are still under high temperature and pressure immediately after the engine has stopped. Removing caps, draining oil and water, or replacing filter elements at that time may cause a burn. Wait until the temperature drops, then begin servicing in accordance with the procedures described in this manual.

**For cleaning the inside of the cooling system, refer to Section "8.2 Nonperiodic services" on page 270.**

**For checking the level of the coolant and the hydraulic oil, refer to Section "Checking before start-up" on page 141.**

**For checking the oil levels in various systems and replenishing the oil, refer to Section "8.3 to 8.6 Periodic services".**

**For replacing the oils in various systems and replacing the filter elements, refer to Section "8.6 to 8.8 Periodic services".**

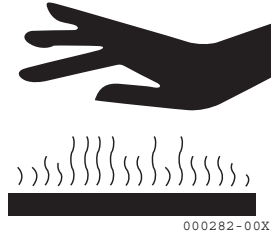

**Lock the inspection cover**

Carrying out servicing with the inspection cover open presents the risk of personnel sustaining injuries caused by sudden closure of the cover due, for example, to strong gusts of wind.

Be sure to lock the inspection cover securely with the cover lock.

After completion of inspection or servicing, always put the inspection cover back in place.

**Hazards from the high-pressure grease when adjusting the track tension**

High-pressure grease is enclosed in the track adjuster.

Failure to use the specified procedures for adjusting the track tension, could cause grease plugs or nipples to eject, which could result in bodily injury.

- Do not loosen the grease draining plug more than one turn.
- Never position your face, hands, legs, or body in line with the grease draining plug and valve.

**For information about adjusting track tension, refer to Section "8.2 Nonperiodic services" on page 270.**



**20**

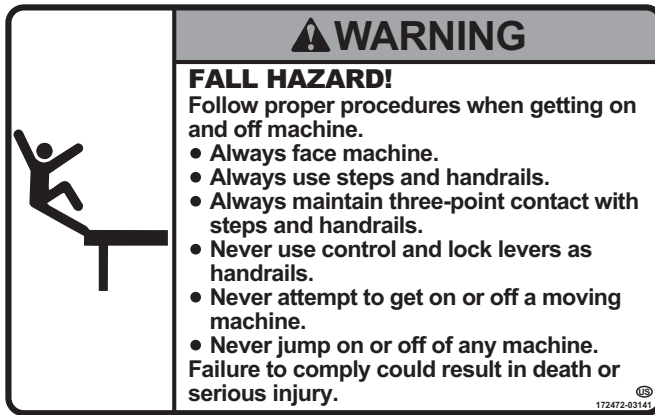

**21**

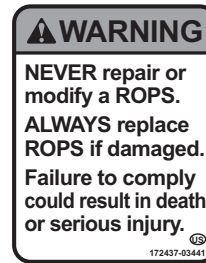

**22** (With quick coupler)



**23** (With quick coupler)



**24** (With quick coupler)



**3 Fuel consumption**

The current fuel consumption is calculated from the amount of fuel used and displayed on the screen. The fuel consumption can be shown or hidden, and the fuel unit can be switched by changing the settings.

For the setting method, refer to "Fuel consumption display setting" on page 105.

**Note:**

*Fuel consumption changes depending on the working load and engine speed.*

*The fuel consumption currently displayed should be used as a guide.*

**4 Fuel meter**

The fuel meter displays the amount of fuel remaining in the fuel tank.

The fuel meter and caution lamp flash when the fuel level in the tank falls below a prescribed level.

When the indicator shows levels close to empty  , the tank should be refueled as soon as possible.

The fuel level indicated by the fuel meter may vary depending on the orientation the machine; for example, when the machine is tilted.

**5 Engine water temp. meter**



This meter indicates the temperature of the engine cooling water.

The meter and warning lamp flash when the cooling water temperature rises abnormally while the machine is operating; at the same time, an error code and an icon indicating that the cooling water temperature is abnormal are displayed on the screen and the buzzer sounds.

If the meter flashes and the buzzer sounds, immediately stop operation and reduce the engine speed to low idle. After the meter indicates low temperatures, stop the engine and carry out inspections according to Section "7.4 Troubleshooting" on page 241.



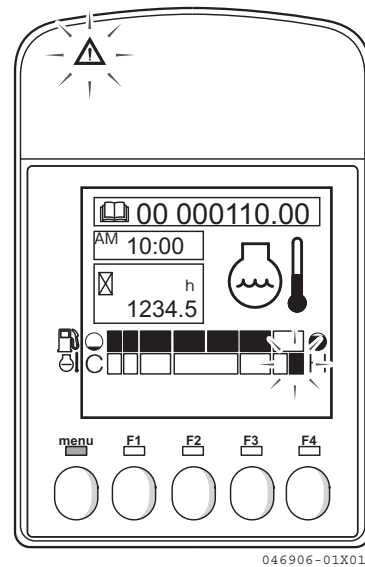

- **Engine water temp. alarm**

If the engine cooling water temperature rises excessively during the operation of the machine, the warning lamp and engine water temp. meter flash, the buzzer sounds continuously and the high temperature icon  and the stop icon  are displayed alternately on the LCD screen. Because this indicates the first signs of engine overheating, immediately stop operation and reduce the engine speed to low idle. After the engine cooling water temperature drops sufficiently, take appropriate corrective measures.



- **Engine oil pressure alarm**

If the engine oil pressure falls outside the normal range, the warning lamp flashes, the engine oil pressure lamp lights up, the buzzer sounds continuously and the engine oil pressure icon  and the stop icon  are displayed alternately on the LCD screen. In such cases, immediately stop the engine and carry out inspections according to Section "7.4 Troubleshooting" on page 241.

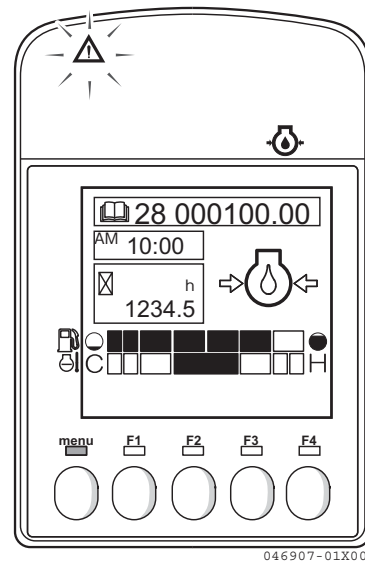

**Resetting the accumulated maintenance time**

After completion of maintenance work, reset the accumulated maintenance time to zero according to the procedure below.

1. Select the item to be reset on the Maintenance Time screen and press the F4 switch  to highlight the accumulated time of the selected item.
2. Press the F3 switch above which (R) is displayed to reset the accumulated time to zero.

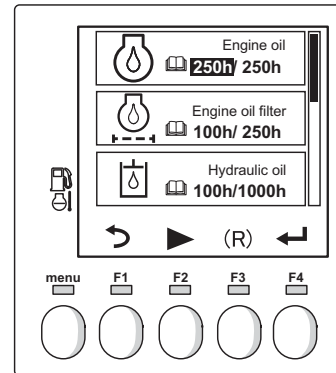

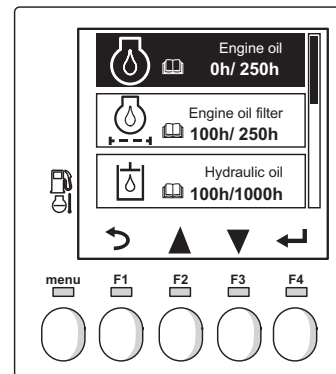

046934-01EN00

3. After "0" is displayed, pressing the F4 switch  to complete the reset procedure will produce a bleep, indicating completion of the setting, and the display will return to the Maintenance Time screen. The date and time and the number of hours indicated on the hour meter are recorded in the maintenance history.





046936-01EN00

**Note:**

To cancel the reset made by pressing the F3 switch (R) to change the value of accumulated time to zero, press the F1 switch  before pressing the F4 switch  to return the value to the previous accumulated time value.



Once the F4 switch  has been pressed, return to the previous accumulated time value is not possible.

**Setting the brightness**

Selecting the brightness icon  and then pressing the F4 switch  brings up the Brightness Setting screen.

This screen allows selecting the brightness level in 5 steps for the LED lamps and LCD screen while the working lamps are on.

The ▼ mark is displayed just above the graduation mark representing the currently selected brightness level and the corresponding number is highlighted.

Move the ▼ mark on the scale to the left or right using the F2 switch  or F3 switch  to select the desired brightness level. The brightness of the LED lamps and LCD screen will change according to the selected level.

Selecting the appropriate level of brightness and then pressing the F4 switch  will highlight the number corresponding to the selected brightness level and produce a bleep, indicating completion of the setting. This completes the brightness setting.

Pressing the F1 switch  will return to the Settings screen.

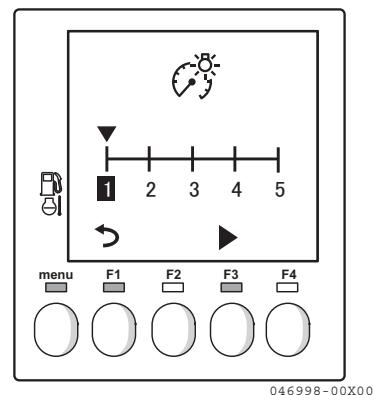
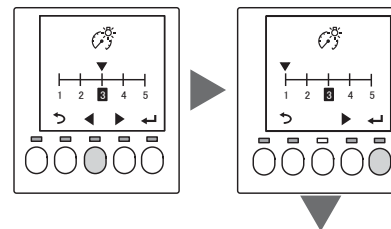
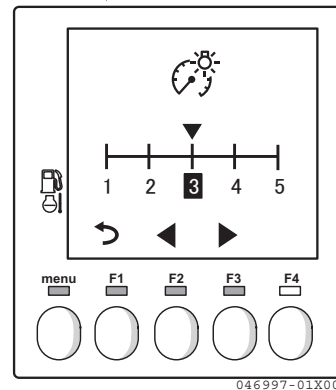
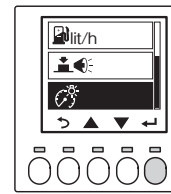

**5 Blade lever**

Use this lever to control the blade.

**IMPORTANT**

**The blade lever is not locked by setting the lock lever to the lock position. Never touch the blade lever when not operating the blade.**

- A** : Down : Push the lever forward.
- B** : Up : Pull the lever backward.
- N** : Neutral : When released, the lever will return to the neutral position and the blade is held as it is.

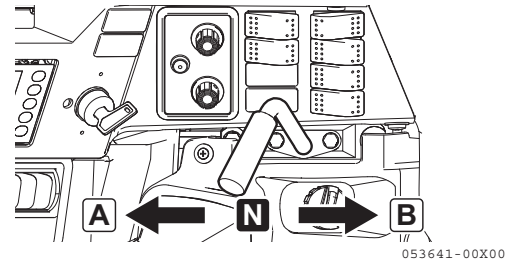
**6 Boom swing pedal**

Use this pedal to swing the boom to right and left.

- A** : Swing right : move to the right.
- B** : Swing left : move to the left.
- N** : Neutral : When released, the pedal will return to the neutral position and the boom is held as it is.

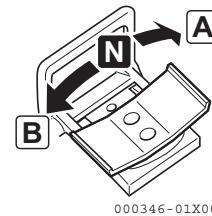
**7 Pedal guard (foot rest)**

The boom swing pedal has a pedal guard.

**⚠ WARNING**

**To avoid bodily injury, securely place the pedal guard in the lock position whenever the boom swing pedal is not being operated.**

Placing the pedal guard in the lock position completely covers the boom swing pedal.

To prevent misuse, always set the pedal guard in the lock position whenever the boom swing pedal is not being operated. The pedal guard can be used as a foot rest.

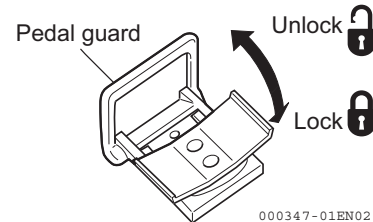

### **3** Entire seat back position control adjustment (forward and backward)

Pull the slide lever **C** upward, to move the seat forward or backward. In this case, the control levers and safety lock levers move together with the seat, so adjust to the best position for operating the travel levers and pedals. The adjustable amount of seat movement is 2.76 in. (70 mm) maximum, in seven separate positions.

### **4** Weight adjustment

The weight adjustment dial **D** is turned and it can adjust to the hardness of the bearing surface cushion with the operator's weight.

- Turn the weight adjuster dial **D** clockwise the setting weight is increased.
- Turn the weight adjuster dial **D** counterclockwise, the setting weight is decreased.

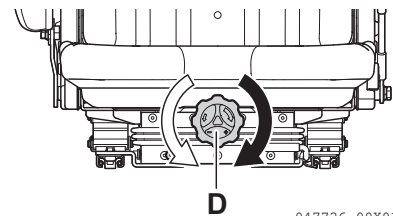

### **5** Height of seat adjustment

The height of the seat can be adjusted by turning height adjustment dial **E**. Adjust the seat pushing it with your hand when you lower the seat.

- Turn the height adjustment dial **E** clockwise, the seat lowers.
- Turn the height adjustment dial **E** counterclockwise, the seat goes up.

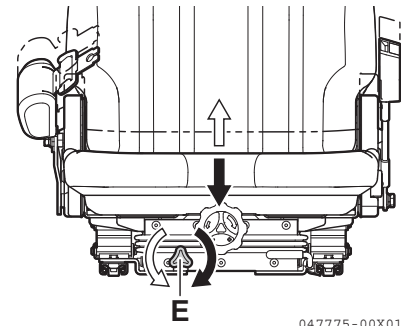

## 2.12 Headlight

### **⚠ WARNING**

**The headlight gets hot when it is turned on. Do not touch it with your bare hand before it cools, to prevent burns.**

The irradiation (direction) of the headlight can be adjusted. Move the light up and down to adjust the irradiation in the direction where the lighting is needed for the nighttime work.

### **IMPORTANT**

**Do not turn the cabin light excessively to prevent damage to the harness.**

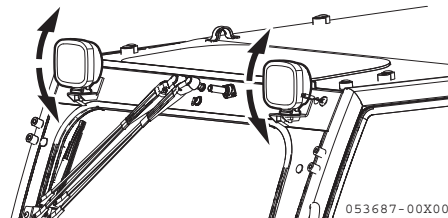

■ **Slow-blow fuse**

When the slow-blow fuse is damaged, contact your dealer.

**Note :**

*To replace the fuses on both ends of the slow-blow fuse box, it is necessary to remove the screws, which are fixing the harness in the bottom of the box.*

## ■ Checking and adjusting the fan belt tension

### **⚠ DANGER**

- Stop the engine, take out the starter switch key, and attach the "SERVICING IN PROGRESS" tag to a control lever.
- The fan belt is hot immediately after the engine is stopped.  
Do not adjust the fan belt tension immediately after stopping the engine.
- Adjust the fan belt tension after all of the parts of the engine have fully cooled down.

### Checking

1. Open the cover 1.
2. Press down on the fan belt 2 between the crankshaft pulley 3 and the generator pulley 4 with a finger, to check the fan belt tension.  
Pressing force:  
Approximately 22.1 lbs. (10 kgf)  
Correct slack: 0.39 to 0.55 in. (10 to 14 mm)
3. Adjust the tension or replace the fan belt if necessary.
4. When the tension is proper, close the cover.

### Adjustment

- Prepare the wooden bar (the handle of a hammer or the like)
1. Open the cover 1.
  2. Loosen the mounting bolts 5 of the generator 4.
  3. Loosen the lock nut 6 of the adjuster.
  4. Turn the adjuster bolt 7 and move the generator 4 so that the generator fan belt will be slacked approximately 0.39 to 0.55 in. (10 to 14 mm) with a pressing load of 72.3 ft•lbf (98.1N•m).
  5. Retighten the mounting bolt 5 to secure the generator 2.
  6. Retighten the lock nut 6 to secure the adjuster bolt 7.

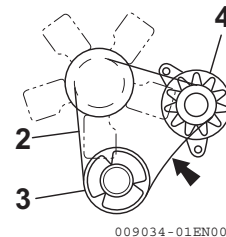
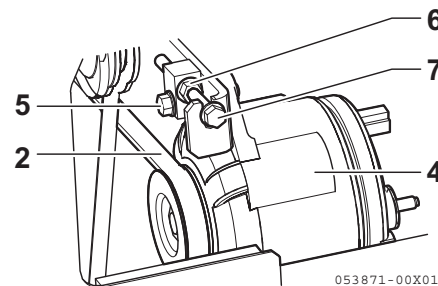
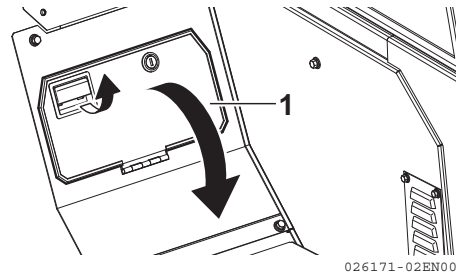

CLICK HERE TO **DOWNLOAD** THE COMPLETE MANUAL

- Thank you very much for reading the preview of the manual.
- You can download the complete manual from: [www.heydownloads.com](http://www.heydownloads.com) by clicking the link below



- Please note: If there is no response to CLICKING the link, please download this PDF first and then click on it.

CLICK HERE TO **DOWNLOAD** THE COMPLETE MANUAL

3. Turn the starter switch key in the starter switch 2 to the "START" position to start the engine.

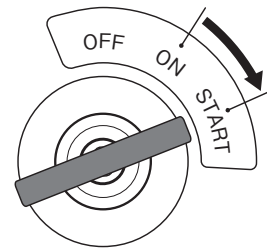

047112-01X00

4. After the engine has started, release the starter switch key.

The starter switch key will return to the "ON" position by itself.

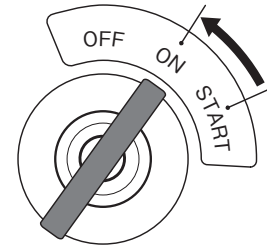

047113-01X00

5. When the engine speed has increased, turn the engine control dial to the IDLING position.

IDLING RUN



026290-01EN00

**IMPORTANT**

To protect the starter motor and the battery:

- Do not keep the starter switch key in the "START" position for more than 10 seconds.
- If the engine fails to start, do not start the engine immediately again, but set the switch to the "OFF" position and wait for approximately 30 seconds, then start the engine again.
- Traveling or operating the machine without adequate warming in cold weather may adversely affect the machine performance.

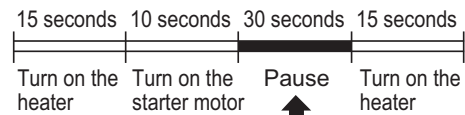

Absolutely required pause

000402-01EN00

## 3.6 Stopping the machine

### ⚠ CAUTION

Do not stop the machine suddenly but provide a safety margin.

### ⚠ WARNING

- Park on solid, level ground.
- Do not park on a slope. If it is unavoidable to park on a slope, place solid blocks of wood behind the crawlers, place the blade on the ground, and dig the bucket into the ground.

### ⚠ WARNING

- Do not touch the control levers and pedals accidentally. Otherwise, the implement or the machine may move unexpectedly, causing serious bodily injury.
- Whenever leaving the operator's seat, be sure to place the lock lever securely in the lock position and remove the starter switch key.

1. Set the right and left travel levers **1** or pedals **2** to the neutral position to stop the machine.

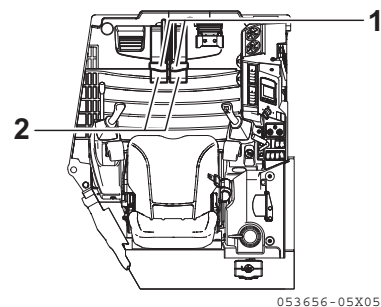
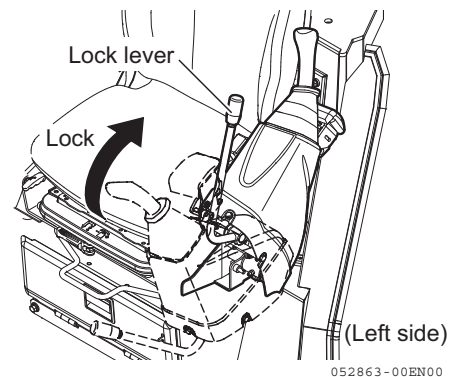
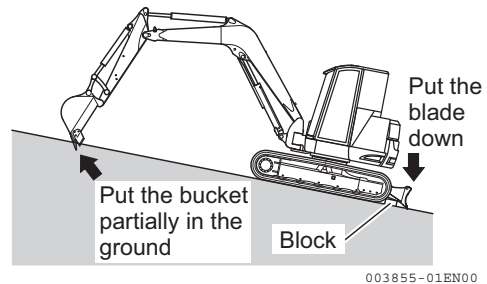

## 3.12 Escaping from the mud

Carefully operate the machine not to allow it to get mired in mud. If the machine is mired in mud, the machine can escape as follows:

### **If only one track is mired in the mud**

If only one track is mired in the mud, place the bucket on the muddy side, lift the track above the ground, lay a log or a wood block under the track shoe, and raise the bucket to escape.

#### **IMPORTANT**

**When lifting the machine above the ground with the boom or the arm, press on the ground with the bottom of the bucket. (Do not press on the ground with the bucket teeth.)**

**In doing this, the angle between the boom and the arm should be 90 degrees to 110 degrees.**

**The same procedure described above should be utilized when the bucket is in the reverse position.**

### **If both tracks are mired in the mud**

If both tracks are mired in the mud, lay a log or a wood block under the track shoes in the same manner as mentioned above, dig the bucket into the solid ground, retract the arm just as when excavating, and push the travel levers forward to escape from the mud.

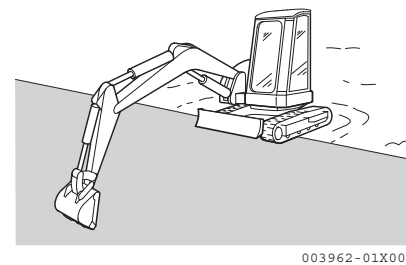
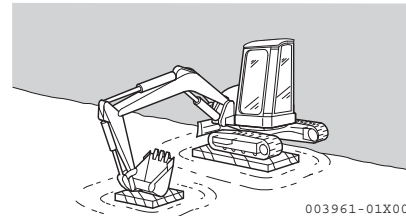

## Other precautions for using the rubber crawlers

---

Observe the following precautions when operating the machine:

- Never spin-turn on concrete or asphalt roads.
- Do not change course suddenly. Doing this will cause the rubber track to wear early or be damaged.
- Do not turn the machine across a large level gap while traveling. Remember that running over a level gap at a right angle will prevent the crawler from coming off.
- Slowly lower the machine after it has been lifted above the ground with the implement.
- It is not recommended that the machine be used to handle any materials that become oily after being crushed (e.g., soybeans, corn, rapeseed oil seeds, etc.). After unavoidably using the machine to handle such materials, clean the crawlers with water.
- It is not recommended that the machine be used to handle materials such as salt, ammonium sulfate, potassium chloride, potassium sulfate, or superphosphate of lime. Handling these materials may affect the core metal adversely. After using the machine to handle such materials, clean the crawlers with water.
- Do not operate the machine at the seashore. Doing this may affect the core metal adversely due to the salt content.
- If a rubber crawler is cracked, it could be easily damaged when exposed to salt, sugar, wheat, or soybeans. Be sure to repair any cracks in the rubber crawler to prevent rubber chips from getting into the materials being handled.
- Do not allow the rubber crawler to rub against a concrete wall.
- The rubber crawlers are prone to slipping on snow or on a frozen road. Be careful of skidding when traveling or operating on a slope in cold weather.

## Dismounting attachment

### **⚠ WARNING**

- Never dismount the Attachment while it is still elevated, as it will drop to the ground and could cause bodily injury.
- Never dismount the Attachment unless it is resting on stable level ground, as it could otherwise fall over.

1. Park the machine on stable level ground.

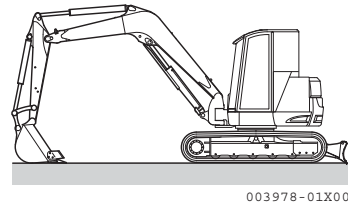

2. Lower the attachment onto the ground.

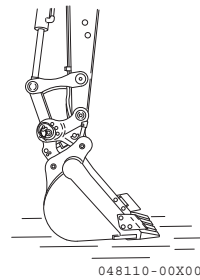

3. Set up the handle of the lock pin.

4. Turn the arrow on the head of the lock pin from the lock position to the unlock position, and then pull it up.

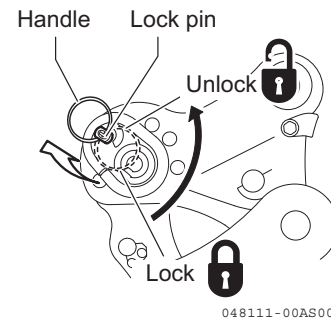

### **IMPORTANT**

**The lock pin cannot be removed from the body.**

5. Open the switch box cover.

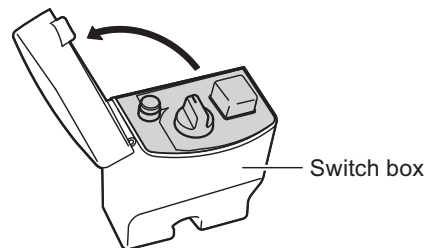

## Operating attachment

### **⚠ WARNING**

- **Emergency stop**  
In cases where the attachment exhibits abnormal movements unintentionally, turn the starter switch to the OFF position to stop the engine or set the lock lever to the lock position, so that the hydraulic power source is shut off and the attachment is stopped. Then, contact your nearest dealer or distributor for inspection.
- **For handling of the attachment, follow the operating instructions supplied by the attachment manufacturer to ensure correct use.**

### **IMPORTANT**

- **Do not operate an attachment such as a breaker continuously for more than 1 minute. Doing so may cause overheating or damage to the attachment.**
- **In cases where P.T.O. is used as a hydraulic power source for a hydraulic hand tool such as a hand breaker, always set the flow control dial to the maximum position so that the hand tool is operated at lower engine speed. Operating a hand tool with the engine running at high speed may cause overheating or damage to the hand tool.**

To operate attachments, follow the procedure below.

#### **■ P.T.O. operation**

Use P.T.O. switch **1** and hold switch **2** on top of the right control lever and P.T.O. flow control dial **3** to the left of the operator's seat to operate an attachment connected to the P.T.O.

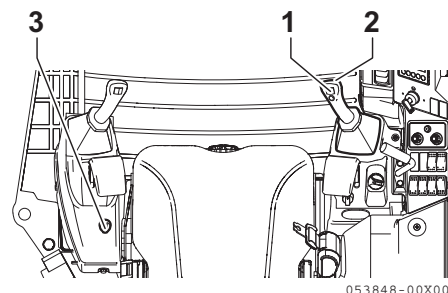

053848-00X00

OPERATION

## Manual regeneration

Frequent repetition of operation of the machine with the engine idling without load or running at low speed and low load may result in insufficient regeneration of the DPF. In such cases, the DPF regeneration icon  will be displayed on the LCD monitor. When the DPF regeneration icon is displayed, manual regeneration must be immediately performed following the procedure detailed below.

### ⚠ WARNING

- During DPF regeneration, the temperature around the exhaust pipe and muffler and the exhaust gas temperature increase to high levels. The machine must be parked in a location where there are no persons or flammable objects and manual regeneration carried out.
- DPF regeneration should be carried out in a well-ventilated, spacious outdoor location. Because exhaust gas contains colorless, odorless harmful carbon monoxide (CO), inhalation of exhaust gas is dangerous and may cause carbon monoxide poisoning.

1. Move the machine to a well-ventilated safe location.
  2. Turn the engine control dial to the low idle position to operate the engine at low idle speed.
  3. Move the lock lever to the lock position to put the machine into locked status.
  4. Pressing the DPF manual regeneration switch to ON position for 3 seconds or more will initiate manual regeneration.
- Once manual regeneration has been initiated, the engine speed will increase gradually to high idle speed and reset regeneration will be performed in this operating status.

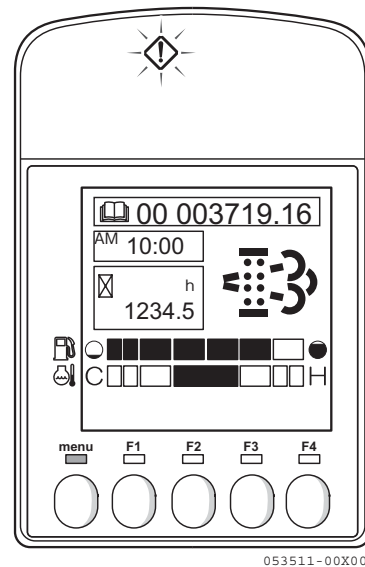

IDLING RUN

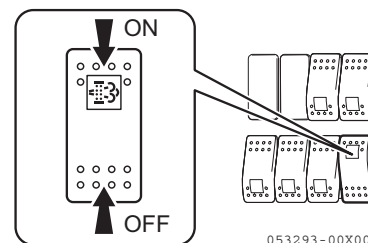
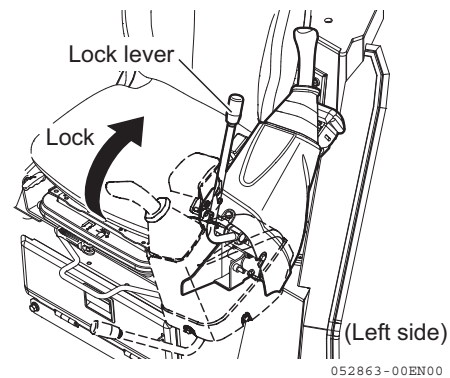

Suspend the machine on the level ground as follows:

1. Swing the upperstructure so that the blade is behind the operator's seat.
2. Raise the blade to the highest limit.

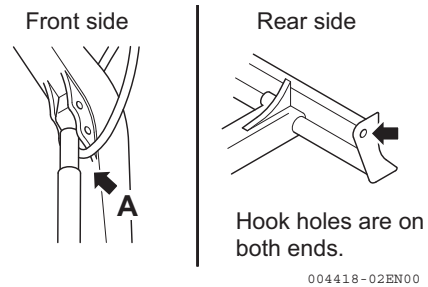

3. Extend the hydraulic cylinders of the front implement (except for the boom swing cylinder) to the maximum.
4. Stop the engine, and make sure that nothing is left around the operator's seat before leaving the machine.
5. Put a slingbelt (or a wire rope) through (A) illustrated in the figure on the right and install shackles in the right and left holes in the side plate of the blade on the rear side, then securely fasten the slingbelt to the shackles.

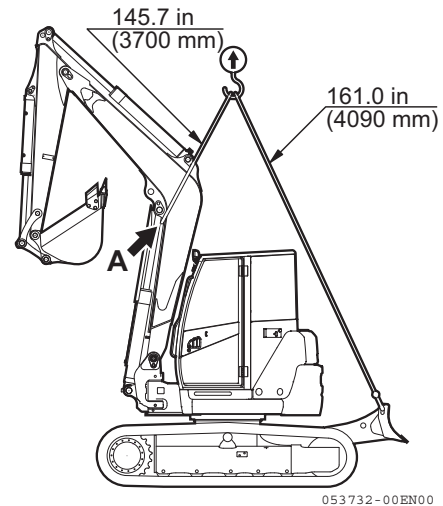

6. Put splints on the machine where the slingbelt touches when the slingbelt is pulled.
7. Suspend the machine above the ground, wait until the machine is stable and then suspend it slowly.

<b>IMPORTANT</b>
<ul style="list-style-type: none"> <li>• For a machine with a cabin, be sure to close the side door and the windshield.</li> <li>• Set each lock lever at the lock position.</li> </ul>

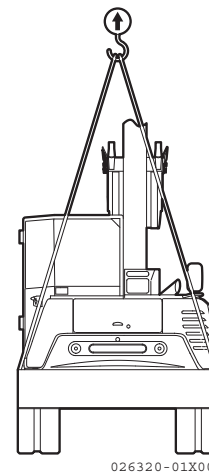

Shipping weight:

lbs. (kg)

Quick coupler
Rubber crawler
With cabin
17968 (8150)

## Starting the engine using booster cables

To start the engine using booster cables, do the following.

### ■ Precautions for connecting and disconnecting the booster cables

#### **⚠ WARNING**

- When you start the engine using booster cables, wear safety goggles.
- If you start the engine by taking electric power from another machine, do not allow contact between your machine and the other machine.
- To connect the booster cables, begin with the positive terminal, and to disconnect them, begin with the negative terminal (ground side).
- If a tool touches the positive terminal and the machine at the same time, hazardous sparks may be generated.
- Do not connect the booster cables to terminals of reverse polarity. That is, never connect a negative terminal on one machine to the positive terminal on the other machine.
- As the last step, connect the negative booster cable to the upperstructure. At this time, sparks will be generated. Connect the terminal to a point as far away from the battery as possible.

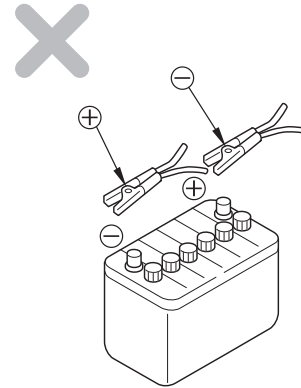

000518-00X01

## 2. Basic Servicing Practices

---

- Use genuine replacement parts.
- Do not mix oils of different makes and types when replacing or replenishing oil.
- The following types of oil, fuel and cooling water are used at the factory for shipping unless otherwise specified:

Item	Type
Engine oil	Engine oil SAE10W30, CJ-4 class
Travel reduction gear oil	Gear oil SAE90 (GL-4)
Hydraulic oil	ISO VG46
Fuel	Diesel light oil (Ultra low sulfur)
Engine cooling water	Long-life coolant (LLC) 51% or 30% + water 51%: U.S.A., Canada, Australia and New Zealand 30%: other countries

Bleed air according to the following procedure:

1. Set the engine rotation to medium. That is, set the lever in the middle of the stroke.
2. Slowly operate each cylinder 4 to 5 times to approximately 4 in. (100 mm) before both stroke ends.
3. Operate the cylinder 4 to 5 times at full stroke.
  - Failure to bleed air from the hydraulic cylinder and operating it suddenly to the stroke ends could cause piston seal damage.
  - If air is left in the hydraulic circuit, it will compress and expand and the hydraulic equipment will not operate smoothly.  
Air in the hydraulic circuit may shorten the service life of the hydraulic pump.
4. Check the hydraulic oil level and replenish hydraulic oil to the specified level if necessary.

◇ : Check ○ : Supply ● : Replace □ : Adjust (clean) ■ : Oil &amp; grease

Check & service items		Daily	Every 50 hrs	Every 100 hrs	Every 250 hrs	Every 500 hrs	Every 1000 hrs	Every 1500 hrs	Every 2000 hrs	Every 3000 hrs
Control equipment	Check performance, play of travel lever (pedal)	◇								
	Check performance, play of control levers	◇								
	Check performance, play of blade lever	◇								
	Check performance, play of boom swing pedal	◇								
	Check performance of engine control dial	◇								
Electric equipment	Check work lights, horn	◇								
	Check hour meter function	◇								
	Check function of LCD monitor	◇								
	Check LED lamps	◇								
	Check wire breakage, short-circuits, loosened terminals retighten	◇								
	Check, resupply battery fluid	◇								
Engine	Check & adjust the intake and exhaust valve clearance						□			
	Lap the intake and exhaust valve seats								□As required	
	Check, clean and test EGR valve									□
	Clean EGR cooler							□		
	Check crankcase breather system							◇		
	Check & clean DPF soot filter									□
	Check & test intake throttle valve									◇
	Check & clean fuel injector									◇

**Note:**

- When machine is used at dusty worksites, clean and replace filter element twice as often as specified in the table.
- Execution of periodic inspection and servicing is indispensable to assuring conformance to EPA emission control regulations.  
Keep a record of the results.

### ■ Installing the rubber crawler

1. Raise the machine with the implement and the safety blocks.

To do this, slowly operate the control lever.

2. Engage the rubber crawler with the sprocket, and place the rubber crawler on the idler.

3. Rotate the sprocket in the reverse direction to push the rubber crawler in, and then stop rotating it.

4. Insert a steel pipe into the rubber crawler, and rotate the sprocket again to place the rubber crawler on the idler.

5. Stop rotating the sprocket, and confirm that the rubber crawler is securely positioned on both the sprocket and the idler.

6. Adjust the rubber crawler tension, referring to Section "Checking and adjusting the rubber crawler tension" on page 272.

7. Confirm that the rubber crawler is fully engaged with both the sprocket and the idler, and that the rubber crawler tension is sufficient. Then lower the machine to the ground.

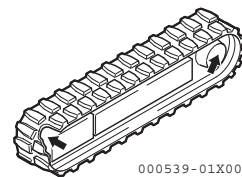
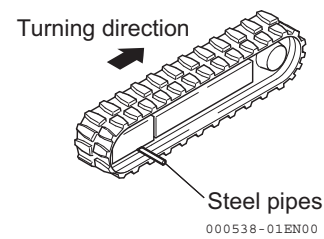
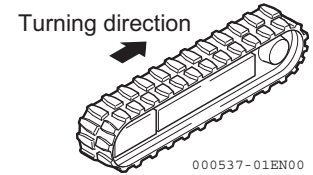
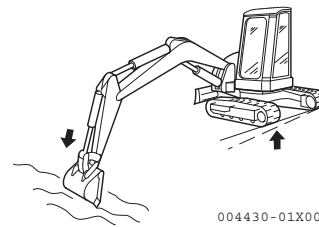

**Check list for the refrigerant quantity**

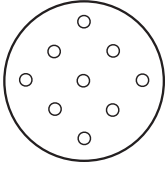
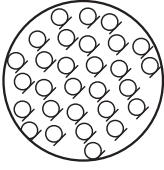
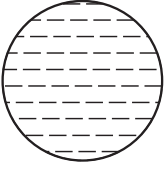
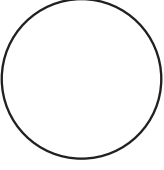
Air conditioner condition	Normal	Abnormal		
Temperatures of high and low pressure pipes	Temperature difference is big. High pressure pipe: hot Low pressure pipe: cold Compressor discharge side temperature: 158°F (70°C) Compressor intake side temperature: 41°F (5°C)	High pressure pipe is warm and low pressure pipe is rather cool. Temperature difference is not so big.	There is almost no difference in temperature between high and low pressure pipes.	High pressure pipe is hot and low pressure pipe is rather warm. There is some difference in temperature between them.
Sight glass	Almost transparent. Even if air bubble flow is seen, it becomes transparent as the engine speed changes.  046691-00X00 *1	Air bubble flow is always seen. It is sometimes transparent or white.  046692-00X00	Flow of mist or the like is seen slightly.  046730-00X00	No air bubble flow is seen even cabin windows, idling engine, and rotating fan to the maximum.  046731-00X00 *2
Pipe connection	Normal	Some parts are contaminated by oil.	Some parts are badly contaminated by oil.	Normal
Refrigerant quantity	Refrigerant quantity is adequate and normal.	Refrigerant might leak in a small amount from some part.	Almost all refrigerant leaks and does not remain.	Refrigerant quantity is too large.

\*1 :When the outside air temperature is low, air bubble might be seen even if the refrigerant quantity is adequate.

\*2 :When there is no refrigerant, no air bubble is seen, either. Therefore, be sure to check the difference in temperature between the high and low pressure pipes.

12. Install the cup **4** to the bracket by tightening the retaining ring clockwise.
13. Close the drain cock **2**.
14. Turn the fuel cock **6** to the ON position.
15. Wipe off the water and fuel adhered to the drain hose **1**.
16. Release the Air. (Refer to page 299)
17. Check the fuel leak.
18. Close the engine hood.

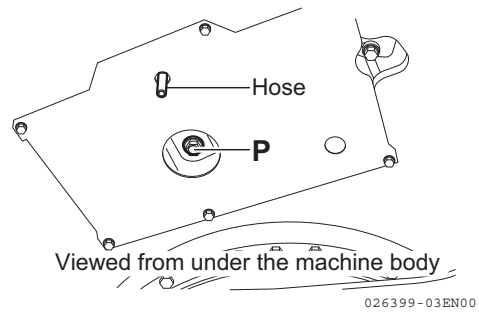

## Replacing the line filter

### **⚠ WARNING**

The oil is hot immediately after ceasing machine operation. Do not replace the filter immediately. Replace the filter after the oil has cooled down sufficiently.

#### ■ Things to prepare

- Container for waste oil
1. Release the internal pressure of the hydraulic circuit.  
For detailed depressurization procedures, refer to Section “Releasing the internal pressure of the hydraulic circuit by accumulator” on page 212.
  2. Open the engine hood cover.
  3. Remove the cover L 1.
  4. Place the container under the line filter.
  5. Put a wrench on the hexagonal bottom portion of the case 6 and turn it counterclockwise to loosen the case 6.
  6. Remove the case 6 and pull out the element 3 from the head 2.
  7. Clean the case 6.
  8. Remove the spring 4 at the bottom of the element 3 and clean it. Then, install it at the bottom of a new element.
  9. Insert the new element into the head 2.
  10. Replace the O-ring 5 on the case 6 with a new one.
  - O-ring size: JASO #2053-Hs90
  11. Screw the case 6 into the head 2.  
Tightening torque: 18.4 to 25.8 ft•lbf (25 to 35 N•m)
  12. Run the engine and check for oil leaks.
  13. Install the cover L 1 and close the engine hood cover.

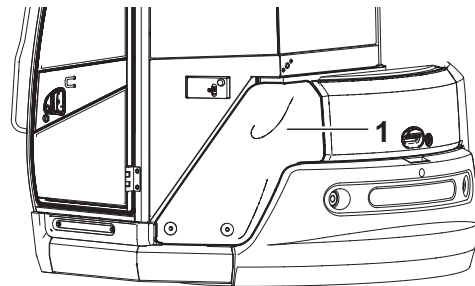

053881-00X00

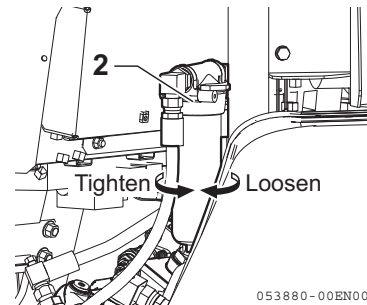

053880-00EN00

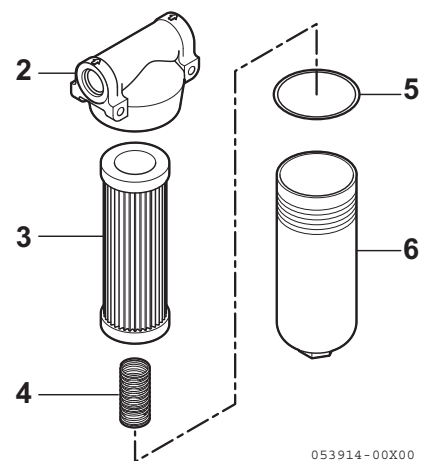

053914-00X00

# OPTIONAL PARTS AND ATTACHMENTS

<b>1. General Precautions .....</b>	<b>318</b>
1.1 Safety precautions .....	318
1.2 Precautions for mounting an attachment (implement) .....	319

CLICK HERE TO **DOWNLOAD** THE COMPLETE MANUAL

- Thank you very much for reading the preview of the manual.
- You can download the complete manual from: [www.heydownloads.com](http://www.heydownloads.com) by clicking the link below



- Please note: If there is no response to CLICKING the link, please download this PDF first and then click on it.

CLICK HERE TO **DOWNLOAD** THE COMPLETE MANUAL