

Cutting Table

18-25 ft PowerFlow

PowerFlow 18' - S/N 701800001

PowerFlow 20' - S/N 702000001

PowerFlow 22' - S/N 702200001

PowerFlow 25' - S/N 702500001

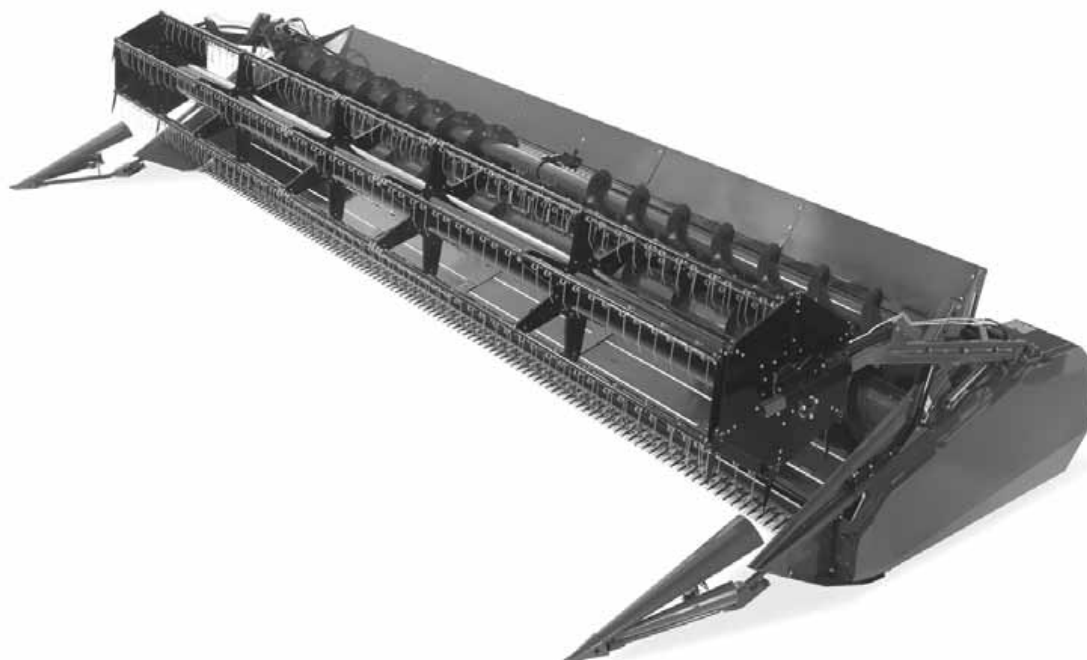

Breganze

**AGCO S.p.A. - Via F. Laverda, 15/17 - 36042
BREGANZE (VI) – Italy.**

FENDT is a worldwide brand of AGCO

© AGCO 2016

Original Operator's Manual

March 2016

FENDT_PF 18'-25'_EN_LA327450010

EAME

English

CLICK HERE TO **DOWNLOAD** THE COMPLETE MANUAL

- Thank you very much for reading the preview of the manual.
- You can download the complete manual from: www.heydownloads.com by clicking the link below



- Please note: If there is no response to CLICKING the link, please download this PDF first and then click on it.

CLICK HERE TO **DOWNLOAD** THE COMPLETE MANUAL

1.1.7 Lubricants

Your Dealer can provide a wide range of special lubricants, produced according to the specific technical specifications of the combine.

For these cutting tables, we recommend the use of the lubricants listed in the **Lubrication and Maintenance** section.

Always use genuine AGCO parts, the only parts which bear this trademark:



Fig. 1

1.1.8 Ecology

Information for the prevention of environmental pollution

Soil, air and water are essential for agriculture and all life on earth. **Protect them.** In areas where no local regulations impose standards for the use and disposal of chemicals and petrochemical products required by modern technology, all necessary precautions must be adopted to avoid any risk of pollution.

The following guidelines may be helpful:

- Find out about the legal requirements in your country and comply strictly with them.
- If no regulations are in force, ask your Dealer about the effects of lubricants, fuels, antifreeze mixtures, cleaning agents etc. on people and the environment. Also ask how to store, use and dispose of such products correctly. In most cases, agricultural advisers will be able to answer your questions satisfactorily.

Important Notes

1. As a rule, avoid any skin contact with liquid fuels, lubricants, acids, solvents etc. Most of these products contain substances that are potentially harmful.
2. **Do not dispose of lubricants by burning: They contain substances that may be noxious when burned.**
3. Whenever possible, use biodegradable oil for lubricating the chains, as this oil cannot be collected.
4. Keep the oil residues in applicable containers. Collect the fluids in suitable containers and dispose of them properly, according to regulations in force and the availability of suitable systems.
5. Immediately repair any leakages or defects in the hydraulic system, to prevent any risk of pollution.
6. When you weld, protect the hoses correctly against welding spatters that could damage or weaken hoses and sleeves, resulting in oil leaks.

1.1.9 Electromagnetic emissions

All electric components of the machine emit an electromagnetic field that varies depending on component features.

Since all situations that may arise in practice cannot be defined in advance, a maximum permissible limit has been set for electromagnetic emissions.

The purpose is to prevent interference and/or damage to the machine control systems.

2.1 Warning symbols and safety instructions

2.1.1 Warnings

Agricultural accidents can be prevented with your help.

All accident prevention depends on the full co-operation of the persons using or involved with service or maintenance of the machine.

Most accidents can be avoided by observing simple safety rules.

The best safety system is one in which the operator observes all applicable regulations for machine safety and maintenance.

Some of the illustrations in this manual can depict cutting tables of the same series with different components than yours. This means that, sometimes, you can notice differences between any particular cutting table and those depicted in this manual.



DANGER:

This symbol is used in this manual whenever your safety is involved. Take the time to read and follow the instructions. Most importantly, be careful! You can never be too prudent. In order to provide a better view, certain photographs or illustrations in this manual may show an assembly with the safety guards open or removed. Fit and close all guards prior to machine operation.

Personal protection

Three types of warning signs appear in this manual and on the decals applied to the machine (**Caution, Warning** and **Danger**) followed by specific instructions or decals with symbols clearly illustrating the type of hazard.

These instructions involve your safety and the safety of people working nearby.

Pay particular attention to these warnings.



CAUTION:

Indicates a potentially dangerous situation. If not avoided, it may result in minor injuries.



WARNING:

Indicates a potentially dangerous situation. If not avoided, it may result in serious injuries.



DANGER:

Indicates a potentially dangerous situation. If not avoided, it may result in very serious injuries or even death.

Failure to follow the instructions related to the terms **Caution, Warning** and **Danger** may result in minor or serious injuries or even death.

Machine safety

Other types of advice (**Note, Important**) are followed by special instructions referring to the safeguarding of the machine.

NOTE:

Highlights and describes correct techniques or procedures to be adopted by the operator.

IMPORTANT:

Informs the operator that unless a special procedure is followed, damage, including serious damage, could be caused to the machine.

3. Operation and adjustment

3.1 Safety	33
3.1.1 Safety Precautions	33
3.2 Cutting table operation	34
3.2.1 Operating principles	34
3.3 Cutting table engagement and disengagement	36
3.3.1 Important information	36
3.3.2 Attachment	36
3.3.3 Removal	39
3.4 Table trailer	40
3.4.1 Information	40
3.5 Cutting table levelling	41
3.5.1 System operation	41
3.5.2 Adjustment of ground sensor	41
3.6 Reel	43
3.6.1 Safety stop	43
3.6.2 Reel Adjustment	43
3.6.3 Bleeding	45
3.6.4 Rotation	45
3.6.5 Reel bars	46
3.7 Knife	47
3.7.1 Knife and knife drive housing	47
3.8 Feeding	48
3.8.1 Table Auger	48
3.8.2 Assembly and adjustment of shims (additional)	49
3.8.3 Replacement of retractable fingers	50
3.8.4 Auger flight extensions	50
3.8.5 Reversing	50
3.9 Drive trains	51
3.9.1 Information	51
3.9.2 Drive train, left-hand side	51
3.9.2.1 Auger speed reduction	51
3.9.3 Cutting table auger slip clutch	52
3.9.4 Drive train, left-hand side	52
3.9.5 Drive train, right-hand side	53
3.10 PowerFlow belts	54
3.10.1 Description	54
3.10.2 Inspection and start-up	54
3.10.3 Adjustment	55
3.10.4 Cleaning	55
3.10.5 Lower part of the cutting table	56
3.11 Scrapers	57
3.11.1 Front Scrapers	57
3.11.2 Rear scrapers	57
3.12 Crop lifter	58
3.12.1 Use	58
3.13 Vertical Knives	59
3.13.1 Description	59
3.13.2 Assembly	60

3.5 Cutting table levelling

3.5.1 System operation

The levelling system controls and adjusts the position of the cutting table in relation to machine movements and ground contours.

Sensors (1) under the table monitor the position of the cutting table relative to the ground. For more detailed information on calibration, read the Operator's Manual for the combine.

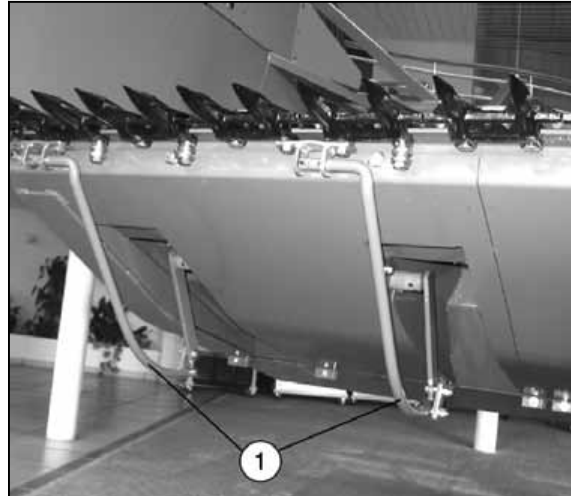

Fig. 11

3.5.2 Adjustment of ground sensor

- Lift the cutting table to have the sliding skids (1) fully opened.
- Position the safety stops on the lift cylinders of the cutting table.
- Switch off the engine.
- Dismount the protection plates (2) on both sides.

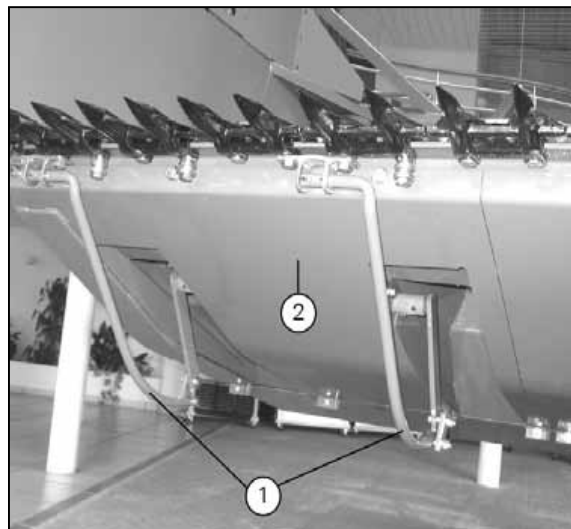

Fig. 12

3.9 Drive trains

3.9.1 Information

Belt and chain tension is maintained with fixed tension pulleys.

Fixed tension pulleys are adjusted by slackening the nut (1) and tightening the belt with the nut (2).

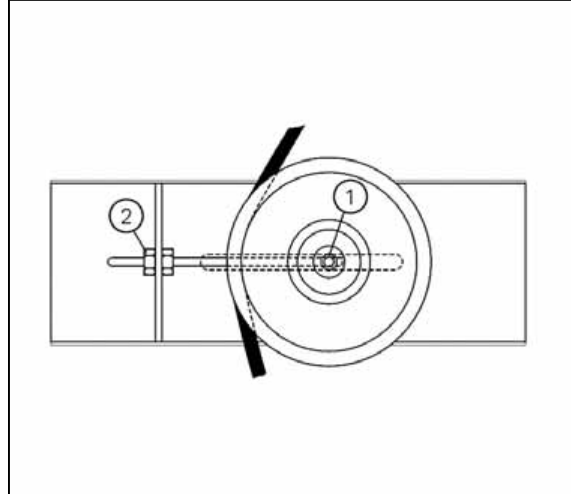

Fig. 27

3.9.2 Drive train, left-hand side

The cardan shaft connects the main crop elevator and the cutting table.

The cardan shaft transmits the motion to the belt (14), which is tightened by the tension pulley (13).

The belt (1) operates the knife; the belt is tightened by the tension pulley (2).

The chain (3), with the sprocket (5), operates the auger and the PowerFlow belts.

Use the sprocket (4) to adjust the chain tension.

The chain (6) operates the PowerFlow belts. Use the sprocket (7) to adjust the chain tension.

The sprocket (5) has a slip clutch that protects the auger against overloads.

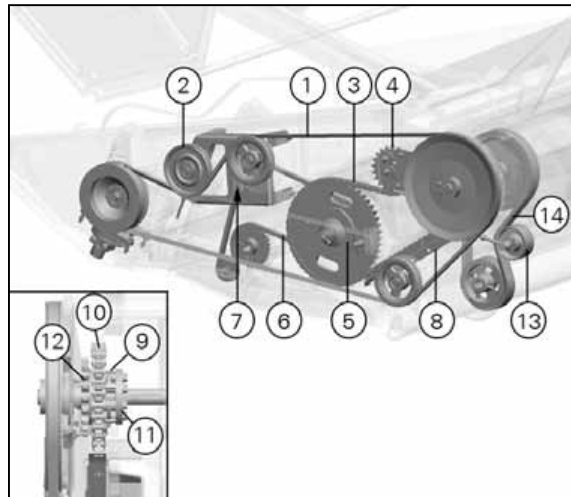

Fig. 28

3.9.2.1 Auger speed reduction

To decrease the speed of the PowerFlow belts and auger, when you harvest certain products such as, for example, rape and peas, proceed as follows.

- Remove the two shims (9)
- Move the sprocket (10) to the right against the flange (11).
- Assemble the two shims (9) to the right of the flange (11).
- Put the chain on the sprocket (12).
- Adjust the chain and the skid again

NOTE: The chain must touch the skid to prevent vibrations in the cutting table.

3.14 Rape auger

3.14.1 Description

The table can be assembled with an auger (1) to cut rape. The rape auger makes feeding better and prevents the rape from falling over the edge of the bar.

NOTE: To guarantee optimum feeding, the transport speed of the rape auger must be the same or slightly higher than that of the table auger.

IMPORTANT: Do not engage the automatic reel speed control when using the rape auger. Otherwise the rape auger may run too high speed resulting in damage of the auger.

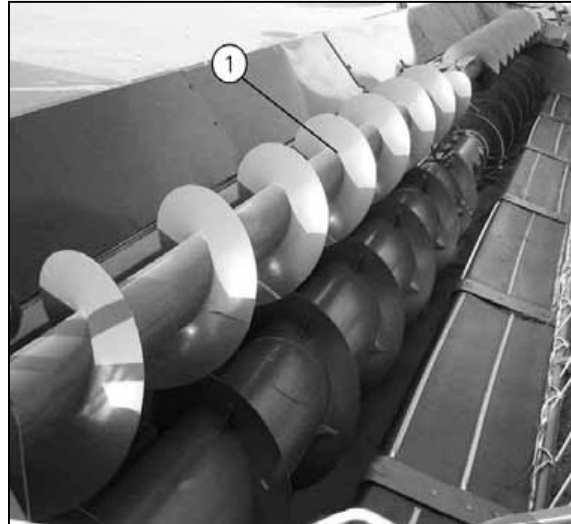

Fig. 42

4.1.3 Lubrication – left-hand side

Retractable fingers (1)

Qty: 19

Colour: Red

Interval: 10 Hours/daily

Lubricant: Oil

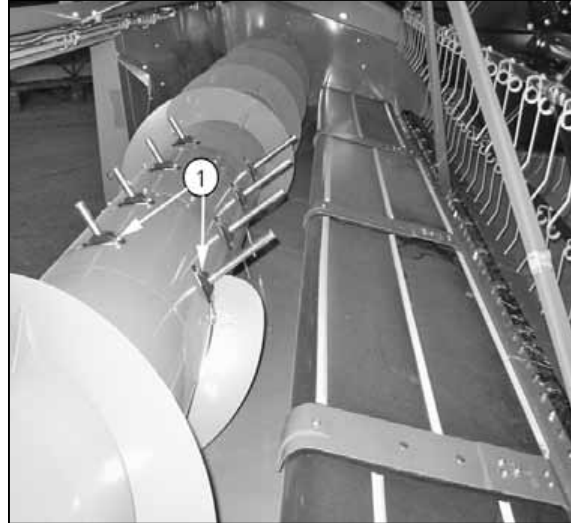

Fig. 3

Cutting table auger clutch (3)

Qty: 1

Colour: Yellow

Interval: 100 h

Lubricant: Grease

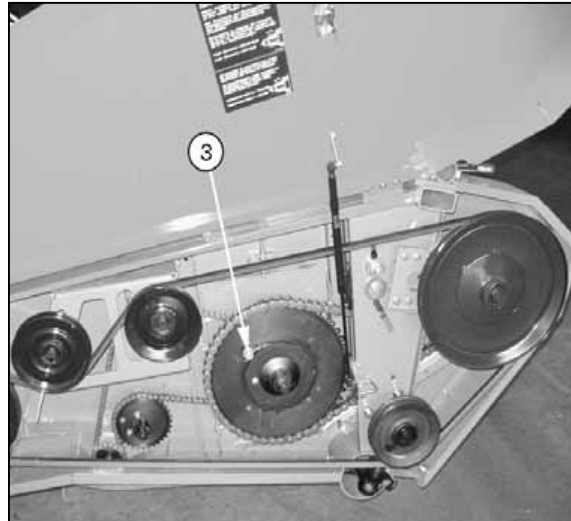

Fig. 4

5.1 Operations to be carried out:

5.1.1 After harvest

The cutting table is an important investment and its lifetime depends on how much care is put into maintaining and handling it.

Do the procedures below at the end of each harvesting season or when the cutting table is to be stored for a long period of time.

In this way, the cutting table will be stored in a good condition and be prepared for the next season.

**WARNING:**

Carry out maintenance work only when the machine is stationary, taking the following precautions:

- **Disengage all drives.**
 - **Lower the cutting table to the ground or secure it safely in the raised position, using the safety stops on the lifting rams.**
 - **Fully lower the reel.**
 - **Switch off the engine, apply the handbrake and remove the ignition key before leaving the operator seat.**
1. Remove the cutting table from the combine and place it on supports or on the table trailer.
 2. Clean the cutting table carefully. Dust and dirt can absorb humidity and cause corrosion of metallic parts.
 3. Open or remove the guards and thoroughly clean the inner parts of the cutting table.
 4. Remove the knife from the cutting table, clean it and protect with anti-corrosive oil.
 5. Clean and lubricate the chains.
 6. Carefully clean all retractable fingers across the full length of the auger. This will prevent rusting of fingers and wear on sliding brackets.
 7. To protect against rusting, coat all unpainted metal parts with paint, anti-corrosive oil or grease.
 8. Lubricate the cutting table; refer to the instructions in the chapter "Lubrication and Maintenance".
 9. Clean the belts and check the tension. Adjust if required.
 10. Clean the painted parts of the cutting table with a rag soaked in oil.
 11. Store the cutting table in a dry and sheltered area.

Periodic maintenance and inspection will help keep service and repair costs at a minimum, preventing expensive breakdowns during the harvest season. However, it is always good practice to carry out a thorough inspection of the cutting table at the end of the season.

Your Dealer will be pleased to submit an estimate and carry out this service for you.

5.1.2 Ordering spare parts

When preparing the cutting table for storage, check for worn parts that need replacing.

The parts must be ordered immediately and installed before the start of the new harvest season.

When ordering spare parts from your Dealer, always state the cutting table model and serial number.

Always ask for genuine parts. These parts ensure the best results.

5.1.3 Before the start of each new season

The following operations must be carried out at the beginning of each new season to ensure the cutting table is in good condition and ready for use.

- Attach the cutting table to the combine.
- Fit the knife.

CLICK HERE TO **DOWNLOAD** THE COMPLETE MANUAL

- Thank you very much for reading the preview of the manual.
- You can download the complete manual from: www.heydownloads.com by clicking the link below



- Please note: If there is no response to CLICKING the link, please download this PDF first and then click on it.

CLICK HERE TO **DOWNLOAD** THE COMPLETE MANUAL