

***DOOSAN***

950106-00375ANA  
July 2014

EXCAVATOR

**Operation &  
Maintenance  
Manual**

**DX255LC-3**

**Serial Number 1001 and Up**

**Serial Number 50001 and Up**

CLICK HERE TO **DOWNLOAD** THE COMPLETE MANUAL

- Thank you very much for reading the preview of the manual.
- You can download the complete manual from: [www.heydownloads.com](http://www.heydownloads.com) by clicking the link below



- Please note: If there is no response to CLICKING the link, please download this PDF first and then click on it.

CLICK HERE TO **DOWNLOAD** THE COMPLETE MANUAL



2. Warning Tag - "Do Not Operate" (950205-03802)



AVOID DEATH OR SERIOUS INJURY

- Stop engine and remove key.
- Attach "DO NOT OPERATE" warning tag to the controls before servicing the machine.
- Do not operate when performing inspection or maintenance.

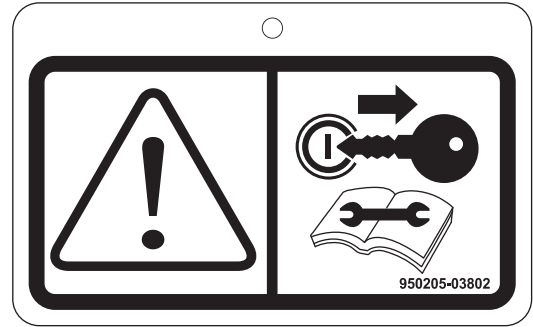

EX1301177

3. Keep Bystanders Away (950205-03803)



AVOID DEATH OR SERIOUS INJURY

- Keep out of swing area and travel path.
- Always look in the travel direction.
- Make sure swing area is clear of bystanders and objects.

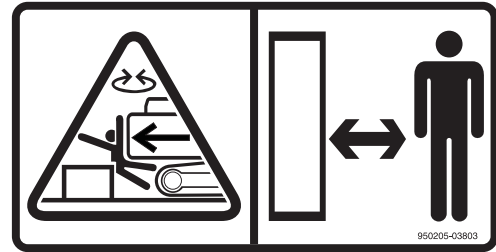

EX1301178

4. Hot Pressurized Fluid (950205-03781)



HOT PRESSURIZED FLUID CAN CAUSE  
SERIOUS BURNS

- Do not loosen or open cap when hot.
- Before opening:
  - 1) Turn engine off.
  - 2) Allow machine to cool.
  - 3) Tip cap and open slowly to relieve pressure.



EX1301180

5. Entanglement in Rotating Parts (950205-03791)



ROTATING PARTS CAN CAUSE DEATH OR  
SERIOUS INJURY

Keep away from belt and rotating parts. Stop engine  
before servicing.

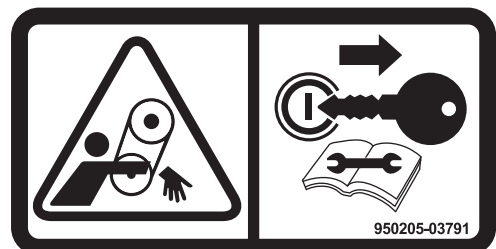

EX1301181

Releasing trapped pressure can cause sudden machine movement or attachment movement. Use caution if you disconnect hydraulic lines or fittings.

High-pressure oil that is released can cause a hose to whip or oil to spray. Fluid penetration can result in death or serious injury. If fluid enters skin or eyes, get immediate medical attention from a physician familiar with this injury.

Obey all local laws and regulations for disposal of liquids.

To prevent hot coolant from spraying out, stop engine and wait for coolant to cool. Using gloves, slowly loosen cap to relieve pressure.

## Flying or Falling Objects

On work sites where there is a potential hazard that flying or falling objects can hit operator's cabin, select and use a guard to match operating conditions for additional operator protection.

Working in mines, tunnels, deep pits, and loose or wet surfaces, could produce hazard of falling rocks or flying objects. Additional protection for operator's cabin could be required such as an Operator Protection Guard (OPG) or window guards. Contact your DOOSAN distributor for information on available protective guards.

To prevent personnel from being struck by flying objects, keep personnel out of work area.

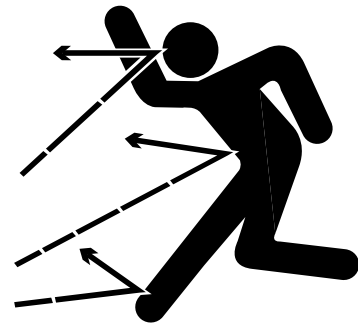

HAOA110L

Figure 5



HAOA100L

Figure 6

### Emergency Exit from Operator's Station

This machine is equipped with a glass breaking tool. It is found on left pillar of cabin. This tool can be used to break the glass to exit from cabin in an emergency. Grip handle firmly and use sharp point to break glass.

- Be careful also not to slip on broken pieces of glass on ground.



**WARNING**

---

**AVOID DEATH OR SERIOUS INJURY**

**Protect your eyes when breaking the glass.**

---

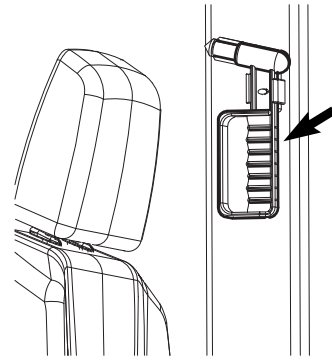

FG015808

Figure 22

## Starting Engine

Only operate the machine from the operator's seat with your seat belt fastened.

Only operate controls while engine is running.

Check for proper operation of all controls and all protective devices while you operate the machine slowly in an open area.

- Read and understand control pattern before operating. Check that movement of the machine matches display on control pattern label. If it does not match, replace it immediately with correct control pattern label.
- Check operation of work equipment, travel system and swing system.
- Check for any problem with machine. Check for unusual sounds, vibration, heat, odor, or improper readings from gauges. Check for any oil or fuel leaks.
- If any problem is found, stop operation and perform repairs immediately.

Do not use cellular telephones inside operator's cabin when driving or operating the machine.

When operating the machine, do not extend your hands or head out of window.

The boom and arm linkage can allow work tool or attachment to contact undercarriage or cabin. Be aware of position of work tool.

- Do not attempt to start engine by short-circuiting engine starting circuit. This can result in death or serious injury, or fire.
- When starting engine, sound horn as a warning to alert personnel in the work area.

If there is a warning tag or "DO NOT OPERATE" tag hanging from work levers (joysticks) or travel control levers, do not start engine or move levers.

- Prevent personnel from walking or standing under raised boom, unless it is properly supported.

**NOTE:** *When starting engine in cold temperatures, "white engine exhaust smoke" from the tail pipe can occur until engine reaches normal operating temperatures.*

*Also, a white residue, because of water vapor inside engine, can form at the engine oil fill location. These conditions will not affect engine performance or damage the engine or other exhaust system components.*

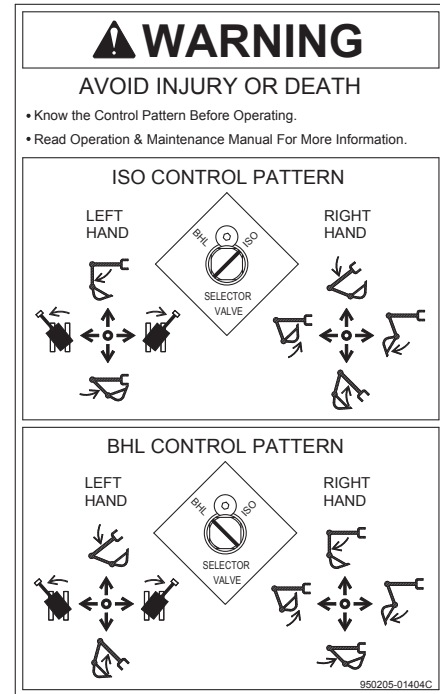

FG018704

Figure 28

# MAINTENANCE

Improper operation and maintenance can result in death or serious injury. Read manual and safety decals before operating or maintaining the machine. Follow all instructions and safety messages.

---



## WARNING

---

### AVOID DEATH OR SERIOUS INJURY

**Follow instructions before operating or servicing machine. Read and understand the Operation and Maintenance Manual and signs (decals) on machine. Follow warnings and instructions in the manuals when making repairs, adjustments or servicing. Check for correct function after adjustments, repairs or service. Untrained operators and failure to follow instructions can result in death or serious injury.**

---

- Never service DOOSAN equipment without instructions.
- Always lower bucket and blade to ground before doing any maintenance.
- Use correct procedure to lift and support excavator.
- Cleaning and maintenance are required daily.
- Welding or grinding painted parts must be done in well ventilated areas.
- Wear a dust mask when grinding painted parts. Toxic dust and gas can be produced.
- Vent exhaust to outside when engine must be running for service.
- Exhaust system must be tightly sealed. Exhaust fumes are hazardous and can cause death or serious injury.
- Stop and allow engine to cool and clean engine of flammable materials before checking fluids.
- Never service or adjust machine with engine running unless instructed to do so in this manual.
- Avoid contact with leaking hydraulic fluid or diesel fuel under pressure. It can penetrate skin or eyes.
- Never fill fuel tank while engine running, while smoking, or when near open flame.
- Keep body, jewelry and clothing away from moving parts, electrical contact, hot parts and exhaust.
- Wear eye protection to guard from battery acid, compressed springs, fluids under pressure and flying debris when engines are running or tools are used. Use eye protection approved for welding.

## Lock Inspection Covers

When performing maintenance with inspection cover open, use lock bar to secure cover and prevent accidental lowering of the cover caused by wind or movement of the machine.

## Working on Machine

When performing maintenance operations on machine, prevent tripping and falling by keeping area around your feet clean and free of objects and debris. Always do the following:

- Do not spill oil or grease.
- Do not leave tools laying around.
- Watch your step when walking.
- Never jump down from machine. When getting on or off machine, use steps and handrails, and maintain a three-point contact (both feet and one hand or both hands and one foot) to support yourself.
- If job requires it, wear protective clothing.
- To prevent injury from slipping or falling, when working on hood or covers, never stand or walk on areas except areas equipped with nonslip pads.
- If it is necessary to work under raised equipment or the machine, support work equipment and machine securely with blocks and stands strong enough to support weight of work equipment and machine.
- Do not work under the machine if track shoes are lifted off ground and the machine is supported only with work equipment. If any control levers are moved, or there is damage to hydraulic system, work equipment or the machine will suddenly drop causing death or serious injury.



Figure 46

ARO1380L

# Operation in Extreme Conditions

## Operation In Extreme Cold

In extremely cold weather, avoid sudden travel movements and stay away from even slight slopes. The machine could slide down the slope.

Snow accumulation could hide potential hazards and slippery surfaces.

Warming up engine for a short period may be necessary to avoid operating with sluggish or reduced working capacity. The jolting shocks and impact loads caused by bumping or bottoming boom or attachment could cause severe stress in very cold temperatures. Reducing work cycle rate and workload may be necessary.

If machine is to be operated in extremely cold weather temperatures, certain precautions must be taken. The following paragraphs detail checks to be made to be certain machine is capable of operating at these temperatures.

1. Preheat the engine before startup.
  - Preheat the engine before startup. Wait 3 to 4 seconds after preheating until voltage of the battery return, and then actuate the key switch.
2. Keep batteries fully charged to prevent freezing. If distilled water is added to batteries, run engine at least one hour to mix electrolyte solution.

When temperature drops below  $-10^{\circ}\text{C}$ , efficacy of the battery is reduced accordingly. Insulation of the battery prevents reduction of efficacy, and supports improvement of starting power of the starter.



## WARNING

---

### AVOID DEATH OR SERIOUS INJURY

**Explosion of the battery can cause serious injury or death. Never attempt to directly heat the battery with open fire.**

---

3. Keep engine in good mechanical condition for easy starting and good performance during adverse weather.
4. Use engine oil with proper specifications for expected temperatures. Refer to "Table of Recommended Lubricants" on page 4-22, in this manual or Shop Manual for details.
5. Always keep the fuel tank fully filled after completion of the operation. Always drain water from the fuel tank before and after the operation. In addition, check the water separator, and drain it if required. The fuel filter, if frozen, may interrupt the flow of fuel. Periodically remove water from the fuel tank, drain water from the filter, and replace the

Reference Number	Description
1	Counterweight
2	DPF
3	Hood
4	Hydraulic Oil Tank
5	Fuel Tank
6	Engine
7	Fuel Tank Fill Cap
8	Cooler
9	Control Valves
10	Swing Motor
11	Air Cleaner
12	Swing Bearing
13	Seat
14	Cabin
15	Boom Cylinder
16	Work Lever (Joystick)
17	Travel Lever
18	Arm Cylinder
19	Boom
20	Arm

Reference Number	Description
21	Bucket Cylinder
22	Guide Link
23	Push Link
24	Bucket
25	Side Cutter
26	Tooth Point
27	Idler
28	Track Adjuster
29	Track Guard
30	Lower Roller
31	Battery
32	Center Joint
33	Upper Roller
34	Sprocket
35	Travel Motor
36	Track Link and Shoe
37	Suction Filter
38	Return Filter
39	Pumps

## 12. Wiper Control Panel

This panel is only for operation of the upper windshield wiper. When the wiper stops running, it moves to right side of the cabin, resting in its support.

**NOTE:** *When the front window is lifted, the wiper motor will not operate.*

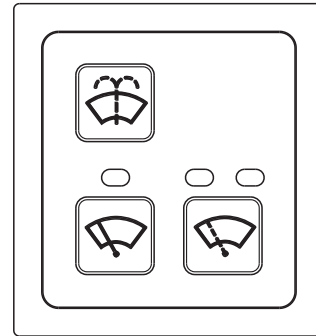

Figure 19

FG000308

### Constant Speed Button

Pressing the button turns "ON" the windshield wiper. An indicator light above the button will turn "ON" indicating that wiper is "ON". The wiper will run at a constant speed.

Pressing the button again, turns "OFF" the windshield wiper.



Figure 20

FG000241

### Intermittent Speed Button

Pressing button once (first time):

Windshield wiper runs approximately on a three second intermittent cycle. The left side indicator light will turn "ON".

Pressing button again (second time):

Windshield wiper runs approximately on a six second intermittent cycle. The right side indicator light will turn "ON".

Pressing button again (third time):

Turns "OFF" the windshield wiper. Both indicator lights will be turned "OFF".

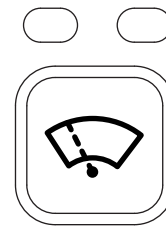

Figure 21

FG000242

### Windshield Washer Button

Pressing the washer button will spray windshield washer fluid onto the windshield. Use only the proper windshield washer fluid in the system.

**NOTE:** *Do not operate the windshield washer without any fluid. If operated without any fluid, the washer motor may be damaged. Check level in washer tank and add fluid as required.*

**NOTE:** *Using soapy water or synthetic detergent instead of window cleaning fluid can damage the wiper blade or painted surfaces. Use standard window cleaning fluid: SSK703*

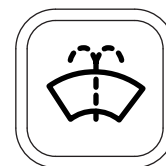

Figure 22

FG000243

## 6. Multimedia Button

Used to select window for video and music (MP3).



# WARNING

## AVOID DEATH OR SERIOUS INJURY

Listening to entertainment clips, such as video, music, etc., can cause an accident resulting in death or serious injury.

Do not play entertainment files when operating the machine.

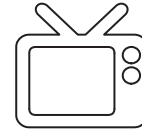

FG018108

Figure 49

## 34. Jack Assembly

1. Hands-free Connector Jack  
Not used on iTIER 4 models.
2. USB Connection  
Used for recharging a cell phone, or playing a video or MP3 file on the display monitor.

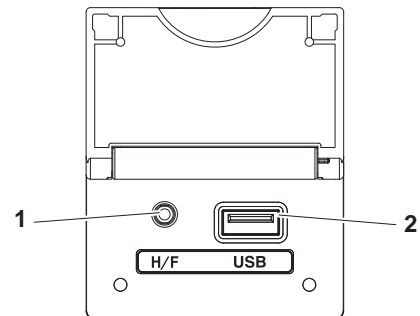

FG018101

Figure 50

## 35. Micro Phone (Optional)

Used for alerting people around machine when starting up or operating the machine.

How to use the microphone:

- A. Siren  
Turn switch (1, Figure 51) on the bottom to "ON" and set switch (2) on the top to the far left position (▷), the siren will be triggered.
- B. Microphone  
Turn switch (1, Figure 51) on the bottom to "ON", set switch (2) on the top to the center position (⊙), and then press switch (3).  
Turn switch (4, Figure 51) clockwise or counterclockwise to increase or decrease the volume.

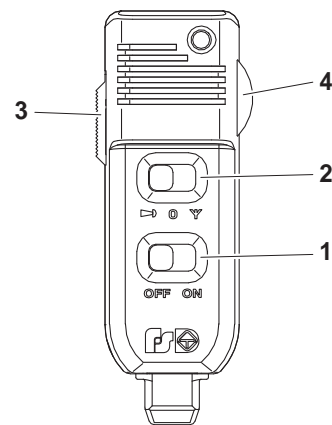

FG018112

Figure 51

## 12. Quick Coupler Release Warning Symbol (Optional)

This symbol indicates when the quick coupler is released.



### WARNING

---

**AVOID DEATH OR SERIOUS INJURY**

**DO NOT OPERATE** machine and attachment if quick coupler switch is in "I" (🔓) position.

**Attachment can fall off causing death or serious injury.**

---



Figure 76

FG002195

## 13. Diesel Particulate Filter (DPF) Regeneration Warning Symbol

The left-hand regeneration symbol (Figure 77) turns "ON" when forced regeneration is required, or during the manual (forced) regeneration process. When the operator inhibits the regeneration, the symbol will be displayed as shown in the right-hand view (Figure 77).

**NOTE:** *Run machine at "LOW IDLE" and do not stop engine until regeneration cycle is completed. See "Engine Exhaust Emission Control System" on page 3-23 for more information.*

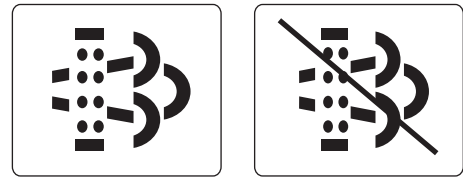

Figure 77

FG018399

---

## IMPORTANT

---

**Move safety lever to "LOCK" position for manual (forced) regeneration.**

**If the equipment is moved or switched off while manual (forced) regeneration, the regeneration will need to be restarted.**

---

**NOTE:** *If the machine is moved or switched off during regenerating, the regeneration process will need to be restarted.*

# USER MENU

## User Menu - Access and Escape Methods

### Access Method

On the normal display screen, click on the jog switch to access the user menu screen.

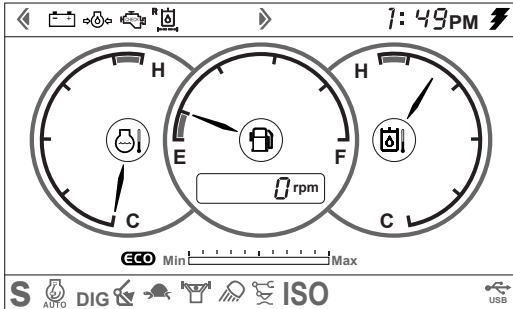

<Normal Indication Monitor>

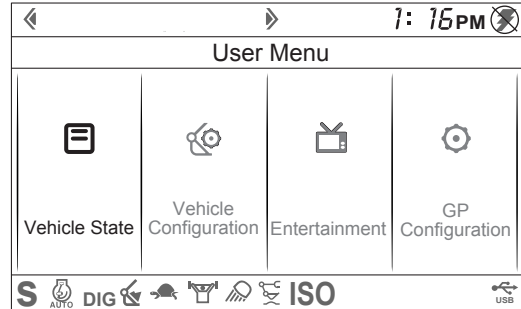

<Main Menu Monitor>

FG018478

Figure 95

### Escape Method

1. Press the ESC button to move to the normal display screen.
2. If 20 seconds have passed without the operation of the button, the normal display screen will be displayed.
3. Turning "OFF" the starter switch to cut off power, you will move to the normal display screen.

### User Menu

Turn the jog switch and move the cursor to see an reversed display on the desired menu. Then, click on the jog switch to select the menu.

**Vehicle State ↔ Vehicle Configuration ↔ Entertainment ↔ GP Configuration**

Press the ESC button to return to the previous screen.

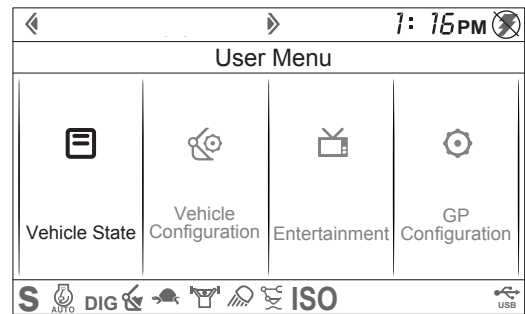

Figure 96

FG018479



**WARNING**

**AVOID DEATH OR SERIOUS INJURY**

**Do not use vehicle state menu when traveling or operating.**

If you access the jog shuttle for dial screen, the initial cursor is located at the using jog shuttle for dial.

If the using jog shuttle for dial is shown as disable, the cursor cannot be moved.

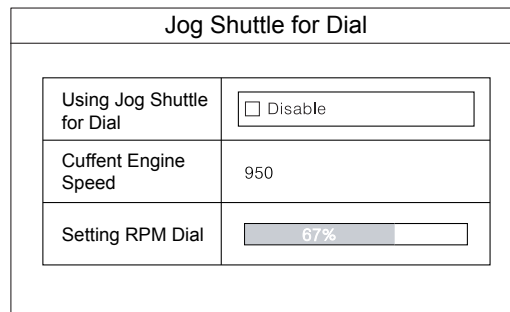

FG018503

Figure 126

When the cursor is placed at the using jog shuttle for dial, if you click on the jog switch, a pop-up window will be created, saying "Use dial for engine rpm?".

Operate the jog switch and select "YES/NO" to determine whether to use jog shuttle for dial.

If you select "YES", then using jog shuttle for dial is enabled, causing the pop-up window to disappear.

If you select "NO", then using jog shuttle for dial remains disabled, causing the pop-up window to disappear.

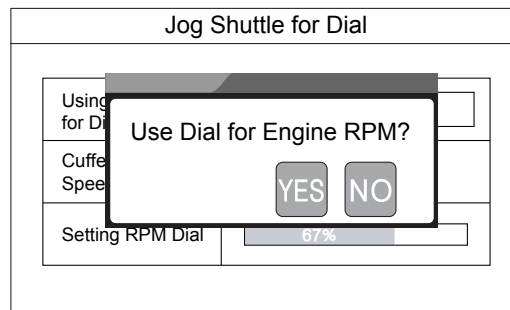

FG018504

Figure 127

If the using jog shuttle for dial is shown as enable, operate the jog switch clockwise and move the cursor to the setting rpm dial. When the cursor is placed at the setting rpm dial, click on the jog switch to cause the cursor to flicker, changing into an editing mode to set up the rpm dial. When the cursor is placed at the editing mode, operate the jog switch clockwise/ counterclockwise, thus setting up the engine rpm.

When the cursor is at the editing mode, press the ESC button to disable the editing mode. When the cursor is not at the editing mode, press the ESC button to return to the previous screen.

Before keying off the gauge panel or disabling the using jog shuttle for dial, control the engine rpm only with the shuttle of the gauge panel's jog shuttle.

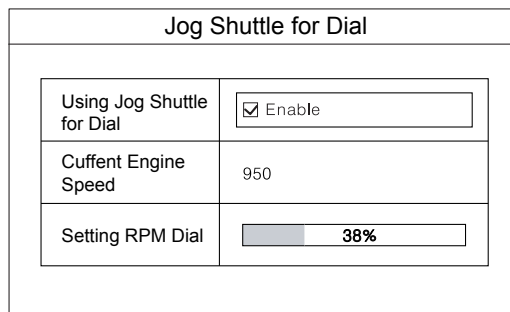

FG018505

Figure 128

### 3. Entertainment

This menu is used to replay videos and MP3.

Turn the jog switch and move the cursor to see a reversed display on the desired menu. Then, click on the jog switch to select the menu.

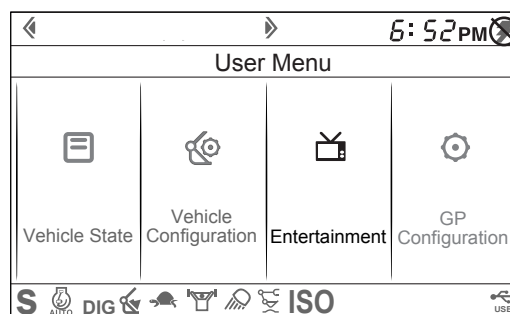

FG018506

Figure 129

## User Password Setting

On the password setting screen, when cursor is placed on the user password setting, click on the jog switch to display the password input screen that was set up at the initial release time. The initial password is set as "1111".

The password input is possible within 10 minutes of turning "ON" the starter switch.

If you have changed the password, you should input it.

---

# IMPORTANT

---

**If password input errors have been made three times in a row, the screen will move to the default screen. After that, starting will be locked for 10 minutes.**

---

## How to Input Password

Turn the jog switch and select numbers of 0 - 9 at the bottom. Then, click on the jog switch and input a password.

If you erroneously input a password, select  key at the right bottom and click on the jog switch to delete the input password.

On the password setting screen, input a password to display a screen to select the application of function (lock), non-application (unlock) and password change.

Turn the jog switch and move the cursor to a target. Then, click on the jog switch to move to the relevant function or a selected screen.

Press the ESC button to return to the previous screen.

Select the lock (applied) or unlock (not applied) in the password setting to enable or disable the password setting function accordingly.

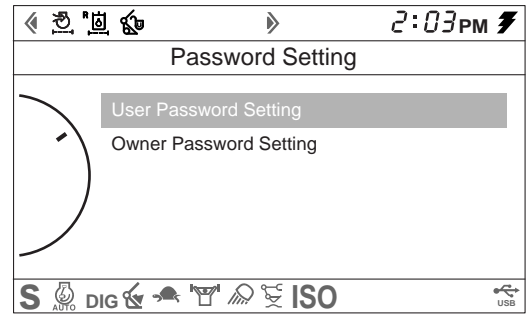

FG018525

Figure 163

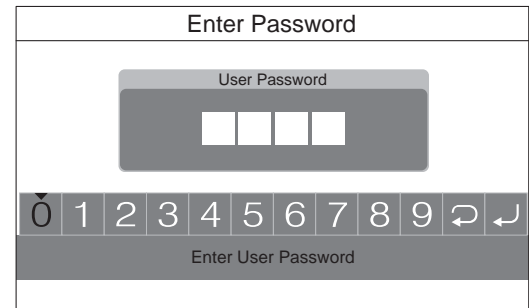

FG018473

Figure 164

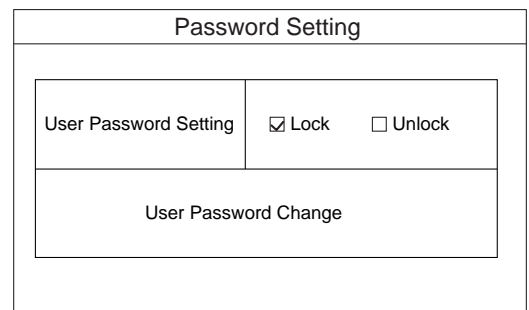

FG018526

Figure 165

8. Shear Selection (Optional)

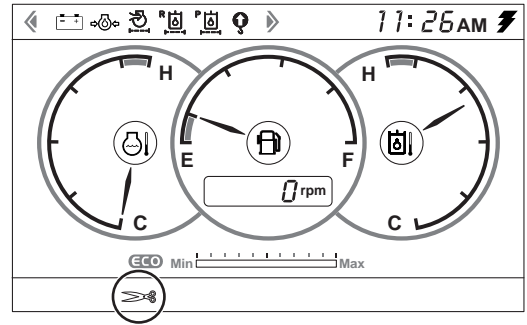

FG018144

Figure 198

9. Quick Coupler Operation Selection (Optional)

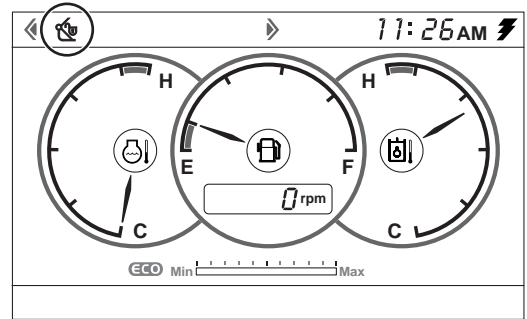

FG018143

Figure 199

10. Ram Rock Operation Selection (Wheel Machine Only)

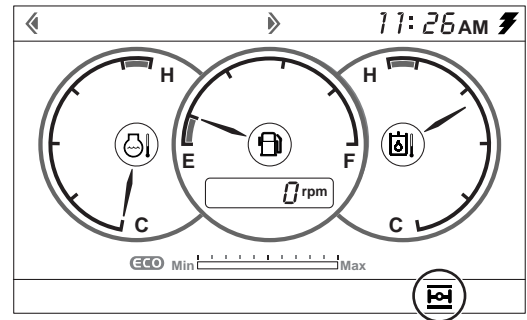

FG018264

Figure 200

11. High Beam Light Selection (Wheel Machine Only)

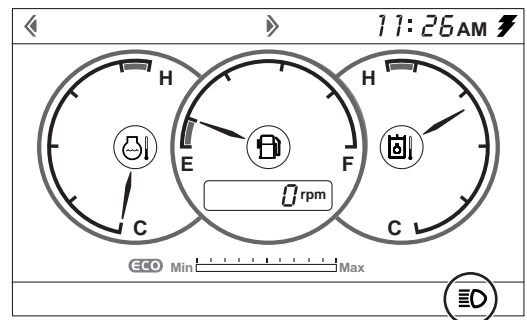

FG018265

Figure 201

# SEAT ADJUSTMENT



## WARNING

### AVOID DEATH OR SERIOUS INJURY

Adjust the seat position before starting operation or after changing the operator.

Do not adjust the seat position while the machine is moving because a loss of control can occur. Always stop the machine, apply the parking brake, and then adjust the seat.

Always fasten your seat belt while operating machine.

Adjust the seat so the control levers and pedals can be operated freely and easily with the operator's back against the backrest.

## 1. Forward/Backward Adjustment

Holding lever (1, Figure 226), raise it up, move the seat to the desired position. Release lever to lock the seat in the selected position. Adjustment range is 180 mm (7.1 in).

## 2. Adjusting Height of Seat and Depth of Cushion

### Forward Tilt

Press the adjustment lever (3, Figure 226) to adjust the seat cushion angle. (0°/+4°/+8°)

### Cushion Slide

Press the adjustment lever (4, Figure 226), and adjust the seat cushion forward/backward by max. 50 mm, to fit with the length of the operator's thigh.

### Seat Height

It is possible to move the seat up or down by combining adjustments forward and rear tilt. Height adjustment is 60 mm (2.4 in).

Adjust height of seat by moving adjustment lever (2, Figure 226) up or down. Seat height can be adjusted by referring to the weight indication window (A, Figure 226) on the right.

- Green: Standard weight
- Red: Underweight or overweight

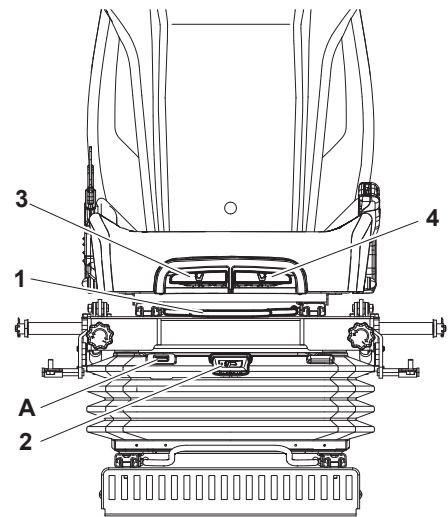

FG018572

Figure 226

# HANGER

A hanger (1, Figure 249) is located on upper left side of operator's cabin.



## WARNING

**AVOID DEATH OR SERIOUS INJURY**

Do not hang anything that will easily fall down or restrict your view out of cabin.

Always check that hanging objects are secured on hanger.

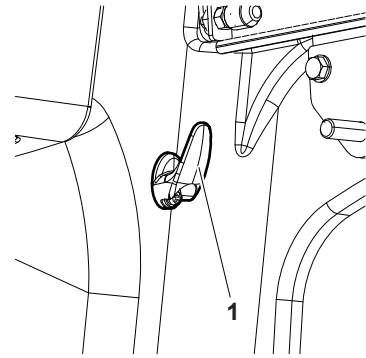

FG015863

Figure 249

# CUP HOLDER

There is a rubber cup holder inside operator's cabin. Use it to keep your cup firmly in place.

## IMPORTANT

When using cup holder, keep the cap closed to prevent spilling.

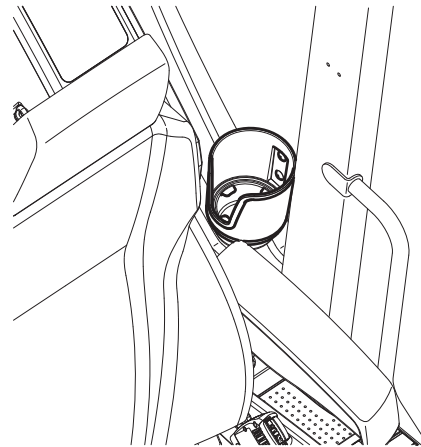

FG018580

Figure 250

# EMERGENCY EXIT GLASS BREAKING TOOL

This machine is equipped with a glass breaking tool. It is found on left pillar of cabin. This tool can be used to break the glass to exit from cabin in an emergency. Grip handle firmly and use sharp point to break glass.

- Be careful also not to slip on broken pieces of glass on ground.



## WARNING

**AVOID DEATH OR SERIOUS INJURY**

Protect your eyes when breaking the glass.

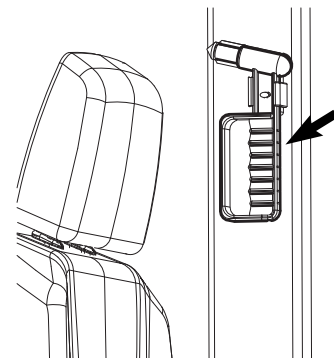

FG015808

Figure 251

# Engine Start

## WARNING

### AVOID DEATH OR SERIOUS INJURY

Start the engine after sounding horn and making sure there are no people or obstacles in the area.

1. Perform all steps in "Operational Checks Before Starting Engine" on page 3-4.
2. Set engine speed control dial to "LOW IDLE" (Figure 3). If control dial is at "HIGH IDLE", the engine will accelerate suddenly and cause damage to the engine.
3. Sound horn.

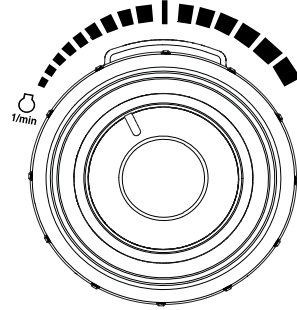

FG018148

Figure 3

4. Turn starter switch to "I" (ON) position.
5. Enter password.

**NOTE:** If the security system is "LOCKED", a four-digit password will be required to start the engine. If the system is "UNLOCKED", no password will be required and this display screen will not appear.

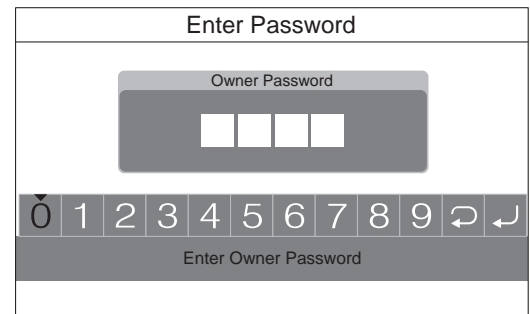

FG018474

Figure 4

6. Turn starter switch to  (START) position (Figure 5). Engine should start in approximately five (5) seconds.

## IMPORTANT

If the engine does not start after approximately fifteen seconds of cranking, release the starter switch. Wait about five minutes and repeat above steps.

7. After engine has started, release key. Key will return to "I" (ON) position (Figure 5).
8. Follow procedures in "Hydraulic System Warm-up" on page 3-12.

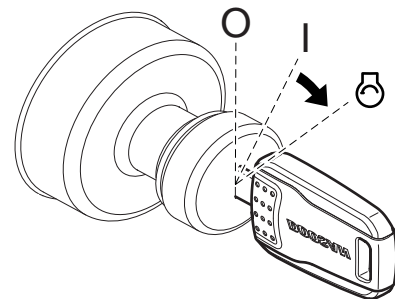

FG018149

Figure 5

## Stopping Engine

**NOTE:** Allow engine to idle for three - five (3 - 5) minutes before stopping the engine. If not allowed to idle, heat surge may develop which will damage the engine. Allowing the engine to idle will allow the engine to cool down.

1. Park machine on firm and level ground.
2. Lower front end attachment to ground and make sure all operating controls are in "NEUTRAL".
3. Move safety lever to "LOCK" position (Figure 24).

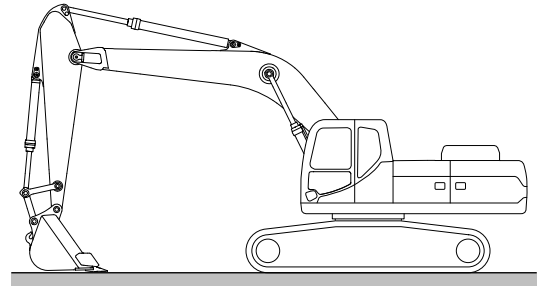

FG018379

Figure 23

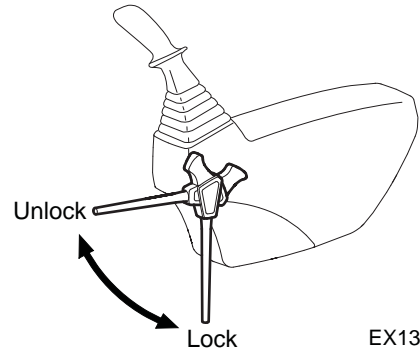

EX1300566

Figure 24

4. Set engine speed control dial to "LOW IDLE" (Figure 25). Allow engine to idle for three - five (3 - 5) minutes.

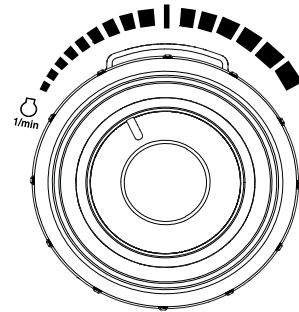

FG018148

Figure 25

5. Stop engine by turning key to "O" (OFF) position (Figure 26).
6. Remove key from starter switch.

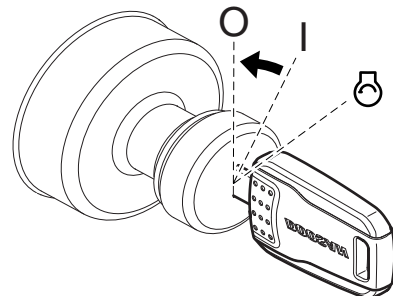

FG018156

Figure 26

CLICK HERE TO **DOWNLOAD** THE COMPLETE MANUAL

- Thank you very much for reading the preview of the manual.
- You can download the complete manual from: [www.heydownloads.com](http://www.heydownloads.com) by clicking the link below



- Please note: If there is no response to CLICKING the link, please download this PDF first and then click on it.

CLICK HERE TO **DOWNLOAD** THE COMPLETE MANUAL

1. Regeneration light: light turns "ON" when regeneration is required, or during the regeneration process. When the operator inhibits regeneration, the symbol will be displayed as shown in the right-hand view of Figure 46.

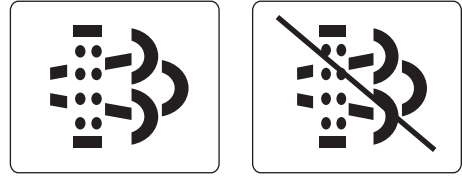

FG018399

Figure 46

2. The high temperature warning light turns "ON" as shown in Figure 47 to alert the operator of hot engine exhaust gases.

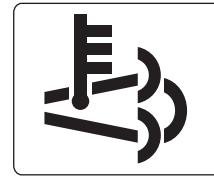

FG018398

Figure 47

3. Manual (forced) regeneration and inhibit switch: the upper symbol in Figure 48 is shown when the operator selects manual (forced) regeneration with the switch. When the operator inhibits regeneration, the lower symbol will be displayed as shown in Figure 48.

**NOTE:** *If manual (forced) regeneration is necessary after the inhibited regeneration switch is turned "ON", press inhibited regeneration switch again to turn "OFF" the inhibit symbol. Press switch to manual (forced) regeneration position to activate system.*

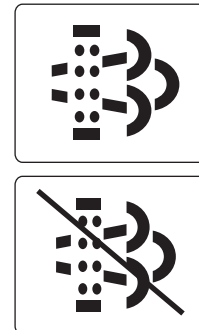

FG018400

Figure 48

## Work Levers (Joysticks) (ISO Pattern)



### WARNING

AVOID DEATH OR SERIOUS INJURY

Check surrounding area before swinging. When operating a lever while in auto idle, proceed with caution because the engine speed will increase rapidly. Keep bystanders away.

**NOTE:** When starting work, move work levers (joysticks) slowly and check movement of swing and front attachment.

This equipment is manufactured using the lever control pattern described in ISO standards. Do not change valving, hoses, etc., that would change this control pattern. The boom, arm and bucket movements and swing direction of work levers (joysticks) are as follows:

#### Left-hand Work Lever (Joystick) (Figure 61 and Figure 62)

1. Arm dump
2. Arm crowd
3. Left swing
4. Right swing

**NOTE:** The swing brake is spring applied and hydraulically released. It is always engaged when the work lever (joystick) is in "NEUTRAL" or the engine is stopped.

**NOTE:** When operating the arm, it may stop momentarily. When the arm is operated, the weight of the arm can cause it to move faster than the amount of oil being supplied.

#### Right-hand Work Lever (Joystick) (Figure 61 and Figure 64)

5. Boom down
6. Boom up
7. Bucket crowd
8. Bucket dump

**NOTE:** Even after stopping the engine, the front can be lowered to the ground by the operating work lever (joystick) by moving safety lever to "UNLOCK" position and turning starter switch "ON".

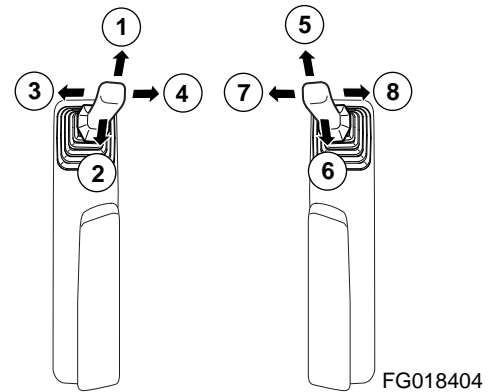

Figure 61

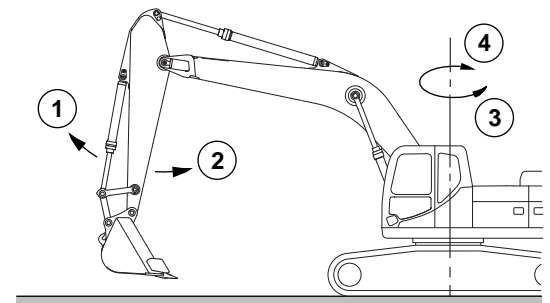

Figure 62

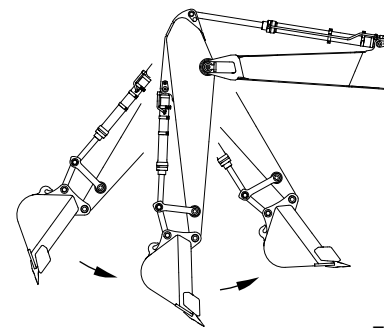

Figure 63

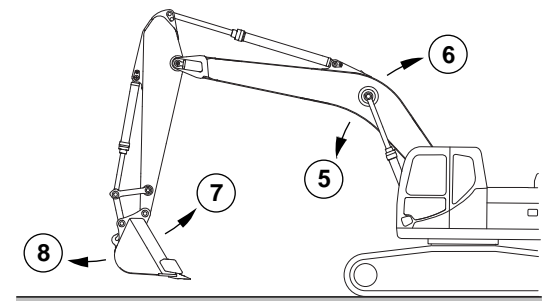
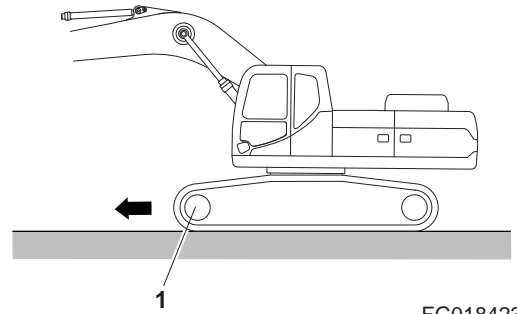

Figure 64

15. To protect undercarriage of the machine when traveling on rough ground or on rocks, set the idler (1, Figure 90) facing in travel direction. The idler and track spring are spring cushioned to absorb direct impacts.



FG018423

Figure 90

16. Do not travel at high-speed over rough ground or rocks. This can result in structural and mechanical failures and can reduce the service life of the machine. See Figure 91.

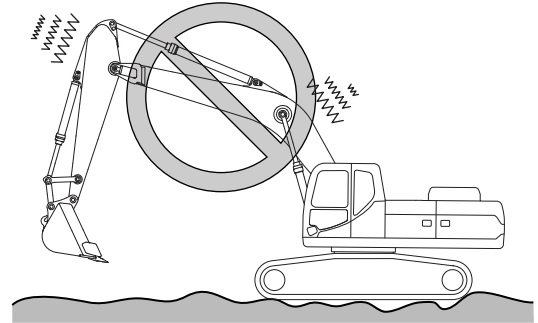

FG018424

Figure 91

17. Do not travel continuously for a long period of time. The lubricating oil temperatures inside the track rollers will rise, and this will cause damage to the oil seal or leakage of oil. If traveling continuously for a long period of time, it is recommended to stop the machine for 15 minutes every 2 hours to allow the lubricating oil inside the track rollers to cool down. See Figure 92.

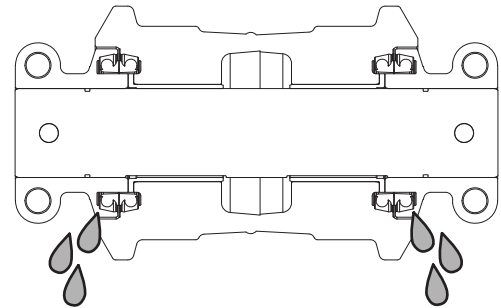

FG018452

Figure 92

7. Do not allow the breaker body to go into water if not equipped for underwater operation. The breaker seal can be damaged and rust, foreign material or water can enter the hydraulic system and cause damage. Only insert the breaker tool into water. See Figure 112.

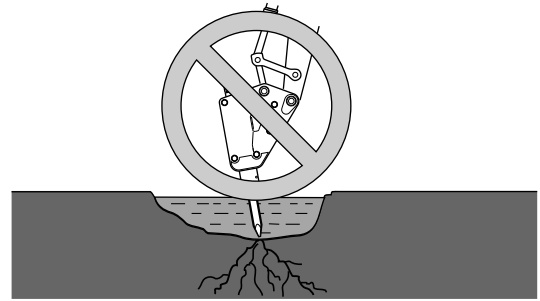

HAOB970L

Figure 112

8. Do not lift or tow with a breaker. See Figure 113.

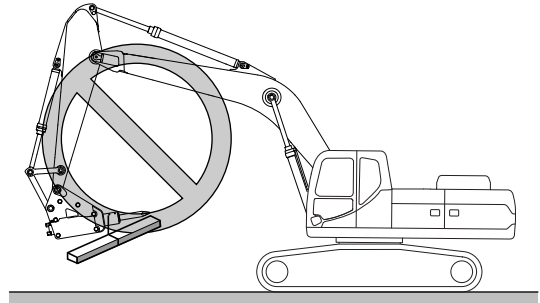

FG018438

Figure 113

9. Operate the breaker only to the front and rear of the excavator. Do not use the breaker to either side of the excavator. Do not swing the breaker from side to side when operating it. See Figure 114.



## WARNING

### AVOID DEATH OR SERIOUS INJURY

Operating a breaker with the upper structure turned 90° to the tracks can result in tipping over the machine or reduction in service life.

10. Do not curl the breaker tool tip into the arm or boom when traveling or parking the excavator. See Figure 115.

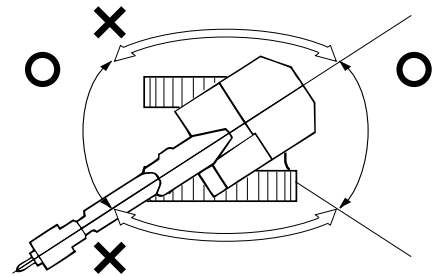

HAOB990L

Figure 114

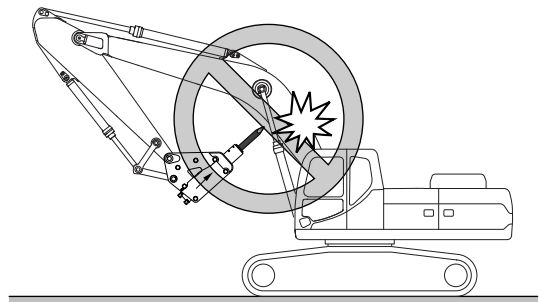

FG018439

Figure 115

# LIFTING OBJECTS

---

## IMPORTANT

---

**There may be local or government laws or regulations governing the use of excavators for the lifting of heavy loads. Always contact local and government agencies and follow all applicable laws and regulations.**

---

When this machine is used in object handling applications, the machine must be properly configured and operated properly. Ensure the following safety working devices equipped and operated.

- Lifting eye for load hooking.
- Hose burst protection on both boom and arm.
- Overload warning devices.

To prevent injury, do not exceed the rated load capacity of the machine. If the machine is not on level ground, load capacities will vary.

Short slings will prevent excessive load swing.

Use the lifting eye on the bucket that is provided to lift objects.

Always try to maintain the lifting eye (Figure 132) straight below the centerline of the arm and bucket pin. In this manner the weight of the load is being primarily held only by the pin, and not by the bucket cylinder, link, and link pins.

When a lifting eye is used, the sling/lifting device must be fastened to the eye in a manner that will not allow it to come loose.

The most stable position is over the corner of the machine.

For best stability, carry a load as close to the ground and machine as possible.

Lift capacity decreases as the distance from the machine swing centerline is increased.

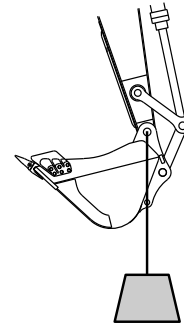

**Figure 132**

HAAD3830

# LONG TERM STORAGE

When a machine is taken out of service and stored for a time exceeding 30 days, steps must be taken to protect the machine. Leaving equipment outdoors exposed to the elements will shorten its life.

An enclosure will protect the machine from rapid temperature changes and lessen the amount of condensation that forms in hydraulic components, engine, fuel tank, etc. If it is not possible to put the machine in an enclosure, cover it with a tarpaulin.

Check that storage site is not subject to flooding or other natural disasters.

After the machine has been positioned for storage and the engine stopped, perform the following operations:

## Before Storage

Keep the excavator in the position shown in Figure 138 to prevent rust of the hydraulic piston rods.

- Inspect for damaged, loose or missing parts.
- Repaint necessary areas to prevent oxidation.
- Wash and clean all parts of machine.
- Store the machine in an indoor, stable place. If stored outside, cover with a waterproof tarp.
- Perform lubrication procedures on all grease points.
- Apply a coating of light oil to the exposed plated metal surfaces (such as hydraulic cylinder rods, etc.) and to all the control linkage and control cylinders. (Control valve spools, etc.)
- Remove battery from the excavator to be fully charged and stored.
- Inspect the coolant recovery tank and radiator to make sure the antifreeze level in the system is correct. Make sure that antifreeze concentration is enough for the lowest temperature anticipated during storage.
- Seal all external openings (i.e. engine exhaust outlet, crankcase and hydraulic breather, fuel vent line, etc.) with tape wide enough to cover the opening, regardless of size.

**NOTE:** *When sealing with tape, be sure to extend tape approximately one inch (25 mm) beyond opening to insure a good seal.*

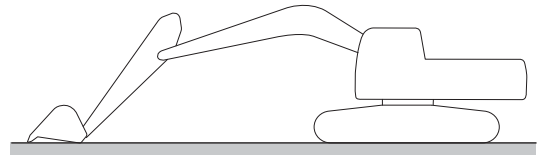

**Figure 138**

EX1300542

- If fuel is used at temperatures lower than specified temperature (particularly at temperatures below -15°C (5°F), the fuel will gel-up and solidify.
- If fuel is used at temperatures higher than specified temperature, the viscosity will drop, and this can cause performance problems.
- Before starting engine, or when 10 minutes have passed after adding fuel, drain sediment and water from fuel tank.
- If engine runs out of fuel, or if filters have been replaced, it is necessary to bleed air from circuit.
- If there is any foreign material in fuel tank, wash tank and fuel system.

---

## **IMPORTANT**

---

**Ultra Low Sulfur Diesel (ULSD) fuel 0.0015 percent ( $S \leq 15$  ppm (mg/kg)) sulfur is required by regulation for use in engines certified to nonroad Tier 4 standards (U.S. EPA Tier 4 certified) and that are equipped with exhaust aftertreatment systems.**

**European ULSD 0.0010 percent ( $\leq 10$  ppm (mg/kg)) sulfur fuel is required by regulation for use in engines certified to european nonroad stage IIIB and newer standards and are equipped with exhaust aftertreatment systems.**

---

Using fuels of higher sulfur level can have the following negative effects:

- Shorten the time interval between aftertreatment device service intervals (cause the need for more frequent service intervals)
- Adversely impact the performance and life of aftertreatment devices (cause loss of performance)
- Reduce regeneration intervals of aftertreatment devices
- Reduce engine efficient and durability
- Increase the wear.
- Increase the corrosion.
- Increase the deposits.
- Lower fuel economy.
- Shorten the time period between Oil drain intervals (more frequent oil drain intervals)
- Increase overall operating costs.

Failures that result from use of improper fuels are not DOOSAN factory defects.

Therefore the cost of repairs would not be covered by a DOOSAN warranty.

# TABLE OF RECOMMENDED LUBRICANTS

## IMPORTANT

It is highly recommend to use DOOSAN Genuine Products or products which meet the following specifications. Using other products can damage the equipment.

**NOTE:** Refer to the "Lubrication and Service Chart" on page 4-16 for locations.

Reservoir	Kind of Fluid	Ambient Temperature											
		-58	-40	-22	-4	14	32	50	68	86	104	122 °F	
		-50	-40	-30	-20	-10	0	10	20	30	40	50 °C	
Engine Oil Pan	5) Engine Oil	2) SAE 5W-40											
		SAE 10W-30											
		3) SAE 10W-40											
		4) SAE 15W-40											
Swing Drive Case	Gear Oil	SAE 90 and API GL5											
Final Drive Case		1) SAE 80W-90 and API GL5											
		SAE 140 and API GL5											
Hydraulic Oil Tank	6) Hydraulic Oil	ISO VG. 15											
		ISO VG. 32											
		1) ISO VG. 46											
		ISO VG. 68											
Fuel Tank	Diesel Fuel	1) ASTM D975 No. 2											
		ASTM D975 No. 1											

# Check Oil Level of Swing Reduction Device



## WARNING

### AVOID DEATH OR SERIOUS INJURY

The gear oil is very hot after the machine has been operating. Shut all systems down and allow them to cool. Before fully removing any motor case inspection, port plug, etc., loosen the plug slightly to allow pressurized air to escape.

**NOTE:** When checking level, use a dipstick and always remove and wipe it clean before making final level check.

1. Remove dipstick (1, Figure 24) and wipe the oil from the dipstick with a cloth.
2. Insert dipstick (1, Figure 24) fully into dipstick tube.
3. When dipstick is pulled out, oil level must be between "HIGH" and "LOW" marks on dipstick.

**NOTE:** If oil is above "HIGH" mark on dipstick, some must be drained to proper level.

4. If the oil does not reach the "L" mark on the dipstick, add oil through fill port (2, Figure 24).

5. If the oil level exceeds the "H" mark on the dipstick, release the drain plug (3, Figure 26). Drain the excessive oil into an approved container.

**NOTE:** Dispose of drained fluids in compliance with all applicable environmental laws and regulations.

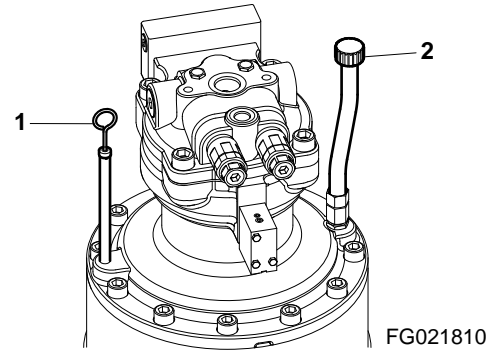

Figure 24

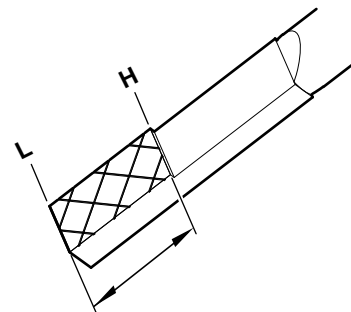

Figure 25

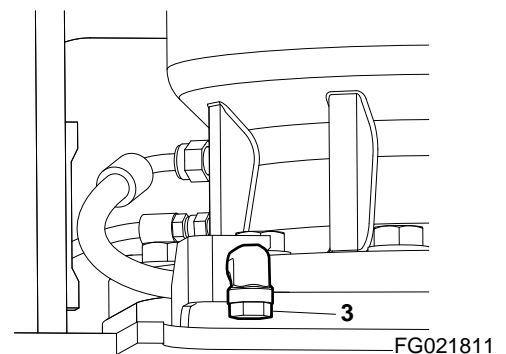

Figure 26

## **Check Engine Fan Belt for Cracks, Wear and Correct Tension (After First 50 Hours)**

1. Inspect after first 50 hours of operation and every 250 hours thereafter. For details, See "Check Engine Fan and Alternator Belts Tension" on page 4-42.

## **Inspect the Track Assemblies for Proper Tension and Loose, Worn or Damaged Parts (Links, Shoes, Rollers, Idlers)**

1. Do a daily walk-around inspection of all components including the track assemblies. Look for missing, damaged or excessively worn parts. See "Track Tension" on page 4-100.
2. Jack up each track and perform the two speed travel motor test.

## Check and Clean Air-conditioning Inner Filter

---

### **WARNING**

---

**AVOID DEATH OR SERIOUS INJURY**

All service and inspection of air-conditioning system must be performed with the starter switch in the "O" (OFF) position.

---

### **WARNING**

---

**AVOID DEATH OR SERIOUS INJURY**

If using compressed air to clean the element, make sure that proper eye protection is worn.

---

1. Remove filter by pulling knob outward while pressing the upperpart and lower part of the filter handle which is inside of the left rear part of the cabin.
2. Use compressed air to clean filter. If the filter is damaged, replace with a new one.

If the filter is very dirty, use a mild soap or detergent and water to clean it.

---

## **IMPORTANT**

---

If water was used to clean filter, be certain that the filter is completely dry before installing.

---

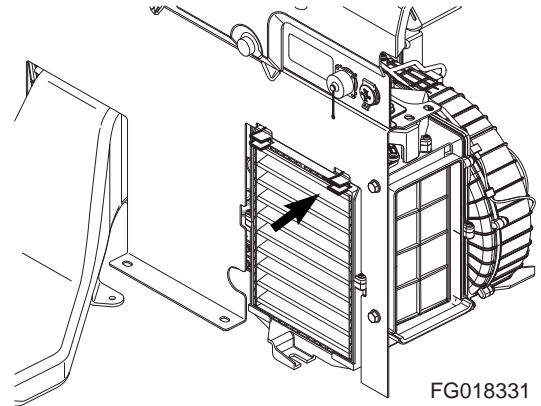

Figure 58

## Change Pilot Filter

**NOTE:** Change pilot filter after first 250 hours of operation or rebuild, and every 1,000 hours thereafter.

**NOTE:** If pilot filter clogged warning symbol (Figure 84) on display monitor comes "ON" the pilot filter must be serviced.



### WARNING

#### AVOID DEATH OR SERIOUS INJURY

The hydraulic oil will be hot after machine operation.

Allow the system to cool down before changing pilot filter.

1. Park machine on firm and level ground. Lower the front attachment to the ground and stop engine.
2. Tip breather cap up (1, Figure 82) slightly to release the internal pressure.
3. Locate pilot system filter assembly. See Figure 85.
4. Unscrew canister (5, Figure 86) and remove O-ring (3) and filter cartridge (4).

**NOTE:** The canister will be filled with oil. Use caution when removing this assembly.

5. Insert a new filter cartridge and O-ring. Apply a small amount of oil around the entire O-ring and install the canister assembly onto the filter head (1, Figure 86).

**NOTE:** Used filter should always be disposed of according to local laws and regulations.

6. After changing pilot filter, vent air from pump and check level of hydraulic oil tank.

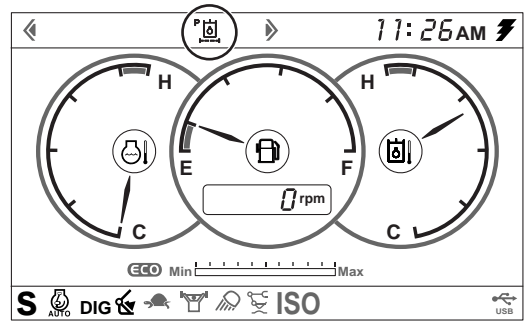

FG018718

Figure 84

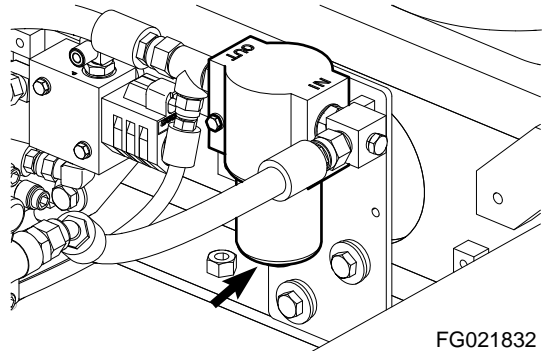

FG021832

Figure 85

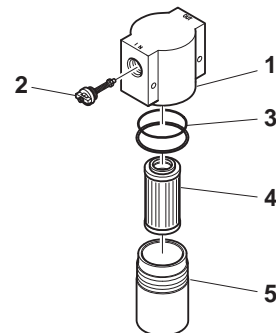

FG021270

Figure 86

3. Remove coolant drain plug (2, Figure 109) from engine.
4. Install drain plug, and close drain valve after coolant has completely drained from system.
5. Fill cooling system with a flushing solution.
6. Run engine at "LOW IDLE" until coolant temperature gauge reaches the "WHITE ZONE". Run engine for another ten minutes.
7. Allow engine to cool.
8. Drain flushing fluid and fill system with water.
9. Run engine again to allow water to completely circulate.
10. After allowing engine to cool, drain water and fill system with proper antifreeze solution for ambient temperature. Refer to coolant concentration table. See "Antifreeze Concentration Tables" on page 4-94.
11. Run engine without radiator cap installed, so all air will be purged from system. Fill radiator to fill neck.
12. Drain and fill radiator coolant recovery tank.

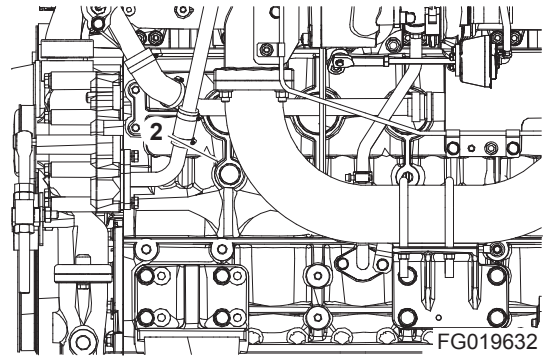

**Figure 109**

## Change Air Compressor Filter (Optional)

1. Open the door of the battery box on the right side of the machine.
2. Remove filter cap (1, Figure 111) manually, remove air filter (2, Figure 110) in the housing, and clean the cap and inside (3, Figure 111) of the housing.
3. Replace the air filter (2, Figure 110), and assemble the filter cap (1, Figure 111).

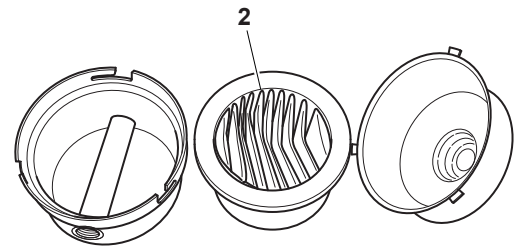

FG015679

**Figure 110**



## WARNING

### AVOID DEATH OR SERIOUS INJURY

Do not try to clean or replace the filter while the air compressor is running.

Wear safety goggles to protect your eyes from flying dust when cleaning or replacing the filter.

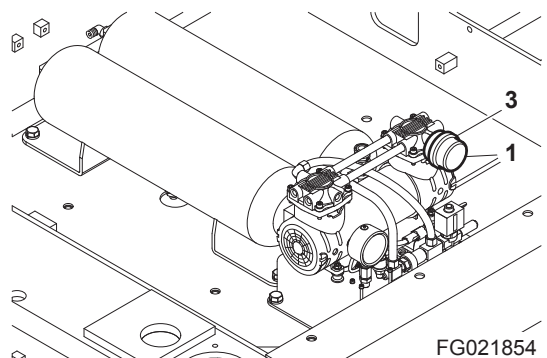

FG021854

**Figure 111**

3. Radiator mounting bolt.

- Tool: 30 mm (  )
- Torque: 55 kg•m (539 Nm, 398 ft lb)

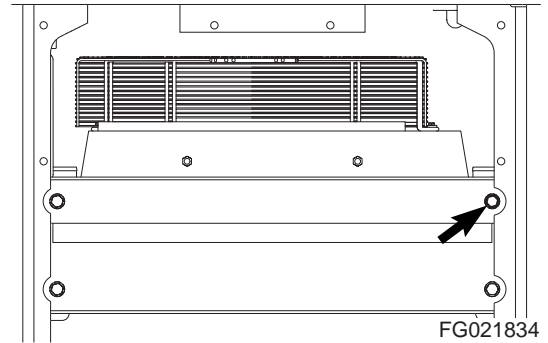



Figure 121

4. Mounting bolt for hydraulic oil tank.

- Tool: 24 mm (  )
- Torque: 27 kg•m (265 Nm, 195 ft lb)

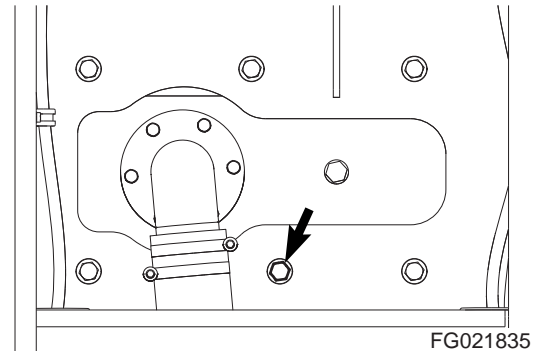



Figure 122

5. Mounting bolt for fuel tank.

- Tool: 24 mm (  )
- Torque: 27 kg•m (265 Nm, 195 ft lb)

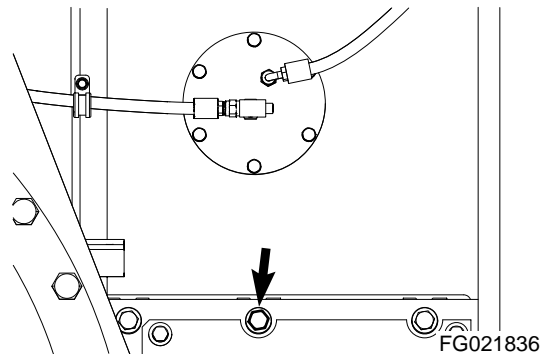



Figure 123

6. Mounting bolt for pump.

- Tool: 17 mm (  )
- Torque: 44 kg•m (431 Nm, 318 ft lb)

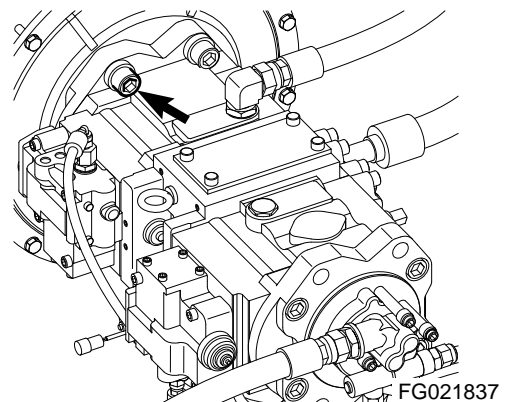
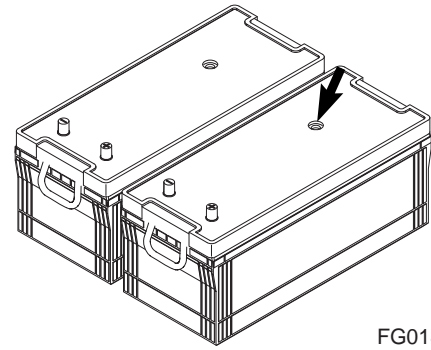

Figure 124

## Inspection of Battery Electrolyte Level

This machine has two maintenance free batteries. They never require the addition to water.

When the charge indicator becomes transparent, this indicates a low electrolyte state because of a leakage or charging system error. Determine the cause of problem and replace the batteries immediately.



FG018362

Figure 151

## Check Charging State

Check charging state through the charging indicator.

- GREEN: Sufficiently charged.
- BLACK: Insufficient charged.
- TRANSPARENT: Replace battery.

## Check Battery Terminals

Be certain that the battery is held securely in its compartment. Clean the battery terminals and the battery cable connectors. A solution of baking soda and water will neutralize acid on the battery surface, terminals, and cable connectors. Petroleum jelly or grease can be applied to the connectors to help prevent corrosion.

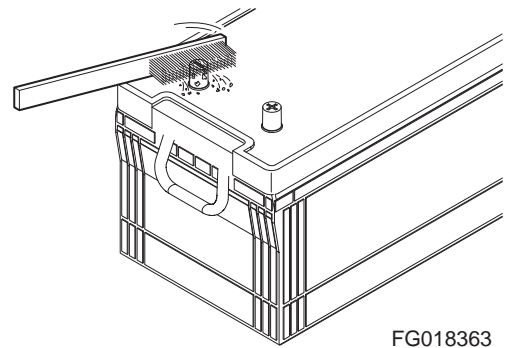

FG018363

Figure 152

## Battery Replacement

When the charging indicator indicates a transparency state, replace the battery. The batteries should always be replaced in pairs.

Using an old battery with a new one will shorten the life span of the new battery.

# HANDLING OF ACCUMULATOR



## AVOID DEATH OR SERIOUS INJURY

Even though the engine is stopped, the hydraulic accumulators for the pilot system are still charged. Do not disconnect any pilot system hoses until accumulator pressure has been released from the circuit. To release pressure, turn the starter switch to "I" (ON) position and operate all hydraulic control levers and forward/reverse travel levers. Even though the engine is stopped, hydraulic actuated components may move while releasing pilot pressure. Keep all personnel and bystanders away from excavator while performing this operation.

- Move safety lever to "LOCK" position after stopping engine.
- DO NOT mishandle accumulator(s), because they contain high-pressure nitrogen gas.
- DO NOT puncture or apply heat or fire to an accumulator.
- DO NOT weld on accumulator, or try attaching anything to it.
- When replacing an accumulator, contact a DOOSAN distributor or sales agency so the gas can be properly released.
- Wear safety goggles and protective gloves when working on an accumulator. Hydraulic oil under pressure can penetrate the skin and cause death or serious injury.

Release pilot accumulator pressure using the following procedure:

1. Park machine on firm and level ground. Lower the front attachment to the ground and stop engine.
2. Move safety lever to "UNLOCK" position.
3. Turn starter switch to "I" (ON) position.
4. Fully stroke work and travel levers in all directions.
5. Move safety lever to "LOCK" position.
6. Turn key to "O" (OFF) position and remove from starter switch.
7. Remove accumulator by unscrewing it slowly.

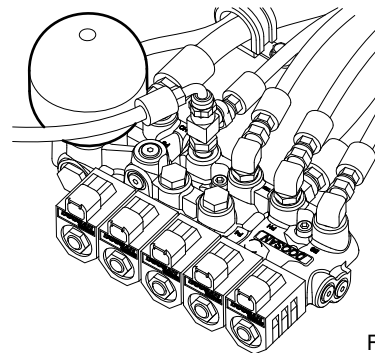

FG021850

Figure 161

5. Turn "OFF" auto idle selector button (1, Figure 7). The indicator symbol will disappear.
6. Move engine speed to "LOW IDLE".

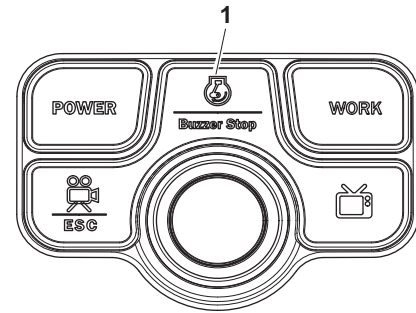

FG018616

**Figure 7**

7. If the machine is equipped with work equipment, position the work equipment toward the front of the excavator, and travel forward to load it.

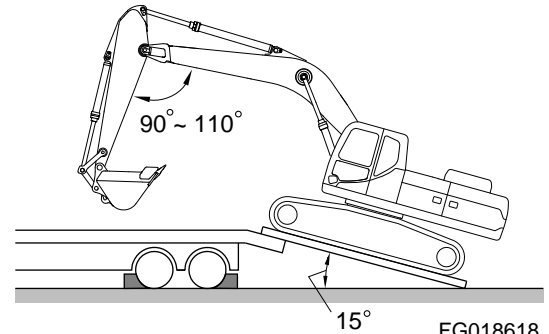

FG018618

**Figure 8**

8. The unit does not require disassembly for normal over-the-road transportation. If the boom and arm need to be removed, the counterweight will place more weight on the rear of the machine. Make sure to back the excavator onto the trailer so the counterweight end (heavy end) of the excavator is positioned on the ramp first. See Figure 9.

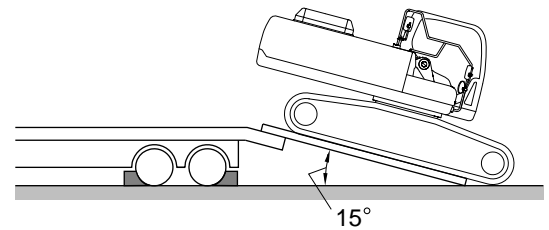

FG018619

**Figure 9**

9. Extend bucket and arm cylinders to maximum length and then lower the boom slowly.

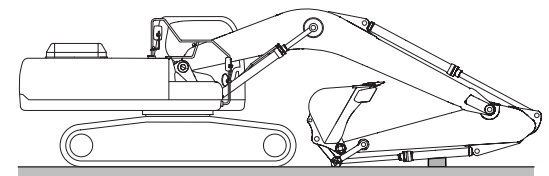

FG018617

**Figure 10**

## COOLING FAN

Problem	Cause	Correction
Cooling fan always runs at maximum speed.	Fan clutch harness is not connected.	Reconnect the connector.
	Fan clutch harness damaged.	Replace as required.
Fan speed is oscillating or lower than minimum speed.	Fan clutch damaged.	Replace as required.

## LUBRICATION SYSTEM

Problem	Cause	Correction
Oil consumption excessive.	Poor oil.	Use suggested oil.
	Oil seal or packing leaky.	Replace.
	Pistons or piston rings worn.	Replace pistons and/or piston rings.
	Cylinder liner worn.	Replace cylinder liner.
	Piston rings sticking.	Replace pistons and/or piston rings.
	Valve guide oil seals or valve guides, or valve stem worn.	Replace.
Oil pressure too low.	Poor oil.	Use suggested oil.
	Relief valve sticking.	Replace.
	Restrictions in oil pump strainer.	Clean strainer.
	Oil pump gear worn.	Replace.
	Oil pump feed pipe cracked.	Replace.
	Oil pump defective.	Correct or replace.
	Oil pressure gauge defective.	Correct or replace.
	Various bearings worn.	Replace.
Oil deteriorates quickly.	Restriction in oil filter.	Replace filter.
	Gases leaking.	Replace piston rings and cylinder liner.
	Poor oil.	Use suggested oil.

# DIGGING FORCE

Description		Unit	5.9 m (19' 4") STD Boom		
			3.0 m (9' 10") Arm	2.5 m (8' 2") Arm	3.5 m (11' 6") Arm
Bucket Radius		mm (in)	1,470 (4' 10")		
Breakout Force	Normal (SAE)	kN	147.7	147.7	147.7
		kg	15,061	15,061	15,061
		lb	33,204	33,204	33,204
	Power Boost (SAE)	kN	156.2	156.2	156.2
		kg	15,928	15,928	15,928
		lb	35,115	35,115	35,115
	Normal (ISO)	kN	166.3	166.3	166.3
		kg	16,958	16,958	16,958
		lb	37,386	37,386	37,386
	Power Boost (ISO)	kN	175.8	175.8	175.8
		kg	17,927	17,927	17,927
		lb	39,521	39,521	39,521
Tearout Force	Normal (SAE)	kN	115.4	138.6	106.5
		kg	11,768	14,133	10,860
		lb	25,943	31,159	23,942
	Power Boost (SAE)	kN	122	146.6	112.5
		kg	12,441	14,949	11,472
		lb	27,427	32,957	25,291
	Normal (ISO)	kN	118.5	143	108.9
		kg	12,084	14,582	11,105
		lb	26,640	32,148	24,482
	Power Boost (ISO)	kN	125.2	151.2	115.1
		kg	12,767	15,418	11,737
		lb	28,146	33,991	25,876
Rotation Angle - Bucket		deg	174.5		

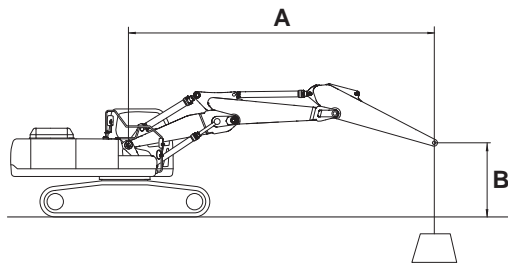













Track Width : 3.2 m (10' 6") STD Track  
 Boom : Lower Boom 3.05 m (10' 0")  
           Upper Boom 3.05 m (10' 0")  
 Arm : 3.5 m (11' 6")  
 Bucket : Without Bucket  
 Counterweight : 5,000 kg (11,023 lb)  
 Shoe : 600 mm (24")  
 : Rating Over Front  
 : Rating Over Side or 360 degree  
 Unit : 1,000 kg (1,000 lb)

FG021868

Figure 15













**METRIC**

1,000 kg

A (m) \ B (m)	3		4.5		6		7.5		9		MAX. REACH		A (m)
													
9					* 5.49	* 5.49					* 4.89	* 4.89	6.20
7.5					* 6.31	* 6.31	* 4.76	* 4.76			* 4.34	* 4.34	7.61
6					* 6.56	* 6.56	* 6.29	5.01			* 4.11	3.99	8.52
4.5	* 7.79	* 7.79	* 7.94	* 7.94	* 7.81	6.93	* 6.62	4.88	* 4.57	3.60	* 4.05	3.53	9.10
3			* 12.15	10.09	* 9.23	6.55	* 7.00	4.69	5.27	3.53	* 4.12	3.28	9.40
1.5			* 13.45	9.33	9.55	6.19	6.80	4.50	5.18	3.44	* 4.32	3.19	9.45
0			* 13.56	8.91	9.26	5.93	6.64	4.35	5.11	3.38	* 4.69	3.25	9.26
-1.5	* 9.60	* 9.60	* 12.56	8.78	9.12	5.80	6.57	4.28			5.25	3.47	8.82
-3	* 13.29	* 13.29	* 10.56	8.85	* 8.18	5.82	* 6.04	4.32			* 4.99	3.95	8.07

**FEET**

1,000 lb

A (ft) \ B (ft)	10		15		20		25		30		MAX. REACH		A (ft)
													
30											* 10.96	* 10.96	19.80
25					* 13.87	* 13.87					* 9.63	* 9.63	24.66
20					* 14.42	* 14.42	* 13.51	10.76			* 9.08	8.89	27.80
15	* 16.19	* 16.19	* 17.07	* 17.07	* 16.95	14.95	* 14.33	10.5			* 8.93	7.81	29.77
10			* 26.24	21.77	* 20.00	14.14	15.10	10.11	11.34	7.59	* 9.08	7.25	30.82
5			* 29.10	20.12	20.56	13.34	14.66	9.70	11.16	7.41	* 9.52	7.05	31.02
0			* 29.42	19.19	19.93	12.78	14.31	9.39	11.02	7.29	* 10.33	7.16	30.40
-5	* 21.76	* 21.76	* 27.27	18.91	19.63	12.52	14.15	9.24			11.60	7.66	28.91
-10	* 28.83	* 28.83	* 22.83	19.04	* 17.59	12.55	* 12.74	9.34			* 10.95	8.77	26.37

1. Load point is the end of the arm.
2. Capacities marked with an asterisk (\*) are limited by hydraulic capacities.
3. Lift capacities shown do not exceed 75% of minimum tipping loads or 87% of hydraulic capacities.
4. The least stable position is over the side.
5. The total weight of machine is 24,654 kg (54,353 lb). Included are the; lower boom 3.05 m (10' 0"), upper boom 3.05 m (10' 0"), arm 3.5 m (11' 6"), 5,000 kg (11,023 lb) counterweight, without bucket, all operating fluids and a 75 kg (165 lb) operator.
6. Lift capacities are in compliance with ISO 10567.

# APPROXIMATE WEIGHT OF WORKLOAD MATERIALS

## IMPORTANT

Weights are approximations of estimated average volume and mass. Exposure to rain, snow or groundwater; settling or compaction because of overhead weight and chemical or industrial processing or changes because of thermal or chemical transformations could all increase value of weights listed in table.

Material	Density 1,200 kg/m <sup>3</sup> (2,000 lb/yd <sup>3</sup> ), or less	Density 1,500 kg/m <sup>3</sup> (2,500 lb/yd <sup>3</sup> ), or less	Density 1,800 kg/m <sup>3</sup> (3,000 lb/yd <sup>3</sup> ), or less	Density 2,100 kg/m <sup>3</sup> (3,500 lb/yd <sup>3</sup> ), or less
Charcoal	401 kg/m <sup>3</sup> (695 lb/yd <sup>3</sup> )	-	-	-
Coke, blast furnace size	433 kg/m <sup>3</sup> (729 lb/yd <sup>3</sup> )	-	-	-
Coke, foundry size	449 kg/m <sup>3</sup> (756 lb/yd <sup>3</sup> )	-	-	-
Coal, bituminous slack, piled	801 kg/m <sup>3</sup> (1,350 lb/yd <sup>3</sup> )	-	-	-
Coal, bituminous r. of m., piled	881 kg/m <sup>3</sup> (1,485 lb/yd <sup>3</sup> )	-	-	-
Coal, anthracite	897 kg/m <sup>3</sup> (1,512 lb/yd <sup>3</sup> )	-	-	-
Clay, DRY, in broken lumps	1,009 kg/m <sup>3</sup> (1,701 lb/yd <sup>3</sup> )	-	-	-
Clay, DAMP, natural bed	-	-	1,746 kg/m <sup>3</sup> (2,943 lb/yd <sup>3</sup> )	-
Cement, portland, DRY granular	-	-	1,506 kg/m <sup>3</sup> (2,583 lb/yd <sup>3</sup> )	-
Cement, portland, DRY clinkers	-	1,362 kg/m <sup>3</sup> (2,295 lb/yd <sup>3</sup> )	-	-
Dolomite, crushed	-	-	1,522 kg/m <sup>3</sup> (2,565 lb/yd <sup>3</sup> )	-
Earth, loamy, DRY, loose	-	1,202 kg/m <sup>3</sup> (2,025 lb/yd <sup>3</sup> )	-	-
Earth, DRY, packed	-	-	1,522 kg/m <sup>3</sup> (2,565 lb/yd <sup>3</sup> )	-
Earth, WET, muddy	-	-	1,762 kg/m <sup>3</sup> (2,970 lb/yd <sup>3</sup> )	-
Gypsum, calcined, (heated, powder)	961 kg/m <sup>3</sup> (1,620 lb/yd <sup>3</sup> )	-	-	-

CLICK HERE TO **DOWNLOAD** THE COMPLETE MANUAL

- Thank you very much for reading the preview of the manual.
- You can download the complete manual from: [www.heydownloads.com](http://www.heydownloads.com) by clicking the link below



- Please note: If there is no response to CLICKING the link, please download this PDF first and then click on it.

CLICK HERE TO **DOWNLOAD** THE COMPLETE MANUAL