

***DOOSAN***

K1024512CE  
July 2014

EXCAVATOR

**Operation &  
Maintenance  
Manual**

**DX190W**

**Serial Number 5409 and Up**

CLICK HERE TO **DOWNLOAD** THE COMPLETE MANUAL

- Thank you very much for reading the preview of the manual.
- You can download the complete manual from: [www.heydownloads.com](http://www.heydownloads.com) by clicking the link below



- Please note: If there is no response to CLICKING the link, please download this PDF first and then click on it.

CLICK HERE TO **DOWNLOAD** THE COMPLETE MANUAL

## Learn Signal Words Used with Safety Alert Symbol

The words "CAUTION", "WARNING", and "DANGER" used throughout this manual and on decals on the machine indicate degree of risk of hazards or unsafe practices. All three degrees of risk indicate that safety is involved. Observe precautions indicated whenever you see the Safety Alert "Triangle", no matter which signal word appears next to "Exclamation Point" symbol.

---

### CAUTION

---

This word is used on safety messages and safety labels and indicates potential of a hazardous situation that, if not avoided, could result in minor or moderate injury. It may also be used to alert against a generally unsafe practice.

---

### WARNING

---

This word is used on safety messages and safety labels and indicates potential threat of a hazardous situation that, if not avoided, could result in serious injury or death. It may also be used to alert against highly unsafe practice.

---

### DANGER

---

This word is used on safety messages and safety labels and indicates an imminent hazard of a situation that, if not avoided, is very likely to cause death or extremely serious injury. It may also be used to alert against equipment that may detonate or explode if handled or treated carelessly.

---

#### Other Signal Words

In addition to safety signal words, the following signal words are used to indicate proper and effective use of machine.

---

### IMPORTANT

---

This signal word identifies procedures which must be followed to avoid damage to machine.

---

**NOTE:** *The word "NOTE" identifies information for effective use.*

15. Impact Hazard (Optional) (950205-03963)



**WARNING**

**AVOID DEATH OR SERIOUS INJURY**

- Activating the Intelligent Floating Boom Control with the tracks raised up can cause the machine to drop suddenly.
- Do not activate Intelligent Floating Boom Control when tracks are raised.
- Do not raise tracks when control is activated.

Refer to "Intelligent Floating Boom Control (Optional)" section of this manual for more information.

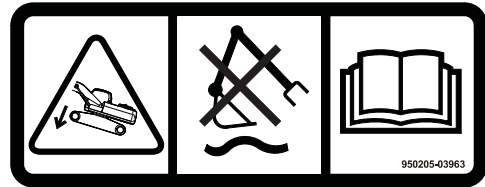

EX1301193

16. Ultra Low Sulfur Diesel Fuel (Optional)  
(950205-03863, 950205-03864)

**IMPORTANT**

Only use Ultra Low Sulfur Diesel (ULSD) fuel with this machine.

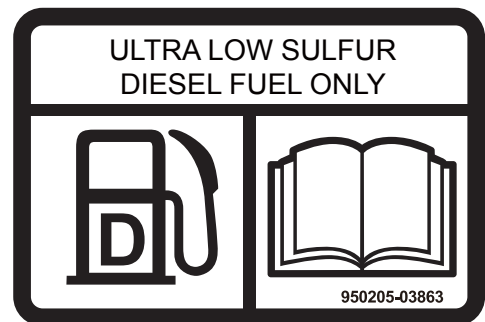

EX1301196



EX1301194

## Clothing and Personal Protective Items

Secure long hair, and avoid loose clothing and jewelry. These items have the tendency to catch on controls or protrude into parts and cause serious injury or death.

Do not wear oily clothes. They are flammable.

Full eye protection, a hard hat, safety shoes and gloves may be required at the work site.

While working on the machine, never use inadequate tools. They could break or slip, causing injury, or they may not adequately perform intended functions.



Figure 5

## Breathing Masks, Ear Protection May Be Required

Do not forget that some risks to your health may not be immediately apparent. Exhaust gases and noise pollution may not be visible, but these hazards can cause disabling or permanent injuries.

**NOTE:** *The equivalent continuous A-weighted sound pressure level at the workstation for this machine is 75 dB(A).*

*Measurement is obtained on a dynamic machine following the procedures and cabin conditions as described in ISO 6396.*

**NOTE:** *The guaranteed sound power level emitted by the machinery for this machine is 101 dB(A).*

*Measurement is obtained on a dynamic machine with the procedures as described in 2000/14/EC.*

## Vibration Level Information

Hands/Arms: The weighted root mean square acceleration to which the hands/arms are subjected, is less than 2.5 m/s<sup>2</sup>.

Whole body: The weighted root mean square acceleration to which the whole body is subjected, is less than 0.5 m/s<sup>2</sup>.

Measurements are obtained on a representative machine, using measuring procedures as described in the following standard: ISO 2631/1, ISO 5349, and SAE J1166.

## Before Operating Machine

If checks are not carried out properly after starting the engine, it can result in a delay in discovering abnormalities in the machine, and this may lead to personal injury or damage to the machine.

Carry out the checks in an open area where there are no obstructions. Do not let anyone near the machine when carrying out the checks.

- Check the operating condition of the equipment, and the movement of the bucket, arm, boom, travel, and swing systems.
- Check the machine for any abnormal noise, vibration, heat, smell, or abnormality with the gauges. Check also for leakage of air, oil, and fuel.
- If any abnormality is found, repair the problem immediately. If the machine is used without repairing the problems, it may lead to unexpected injury or failure.
- Clear all personnel from directly around machine and from the area.
- Clear all obstacles from the machine's path. Beware of hazards.
- Be sure that all windows are clean. Secure the doors and the windows in the open position or in the shut position.
- Adjust the rearview mirrors for best visibility close to the machine. Make sure that horn, the travel alarm (if equipped), and all other warning devices are working properly.
- Fasten the seat belt securely.
- Warm up the engine and hydraulic oil before operating machine.
- Before moving the machine, check undercarriage position. The normal travel position is with idler wheels to the front under the cabin and the drive sprockets to the rear. When the undercarriage is in the reversed position, the travel controls must be operated in opposite directions.

## Proper Tools

Use only tools suited to the task. Using damaged, low quality, faulty, or makeshift tools could cause personal injury. There is a danger that pieces from, chisels with crushed heads, or hammers, may get into your eyes and cause blindness.

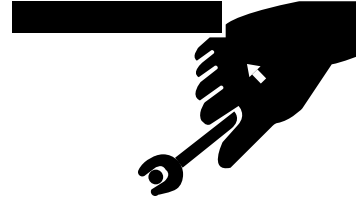

Figure 35

HDO1037L

## Use of Lighting

When checking fuel, oil, battery electrolyte, or window washing fluid, always use lighting with antiexplosion specifications. If such lighting equipment is not used, there is a danger of an explosion.

If work is carried out in dark places without using lighting, it may lead to injury, so always use proper lighting.

Even if the place is dark, never use a lighter or flame instead of lighting. There is a danger of fire. There is also danger that battery gas may catch fire and cause an explosion.



Figure 36

HDO1040L

## Fire Prevention and Explosion Prevention

All fuels, most lubricants and some coolant mixtures are flammable. Leaking fuel or fuel that is spilled onto hot surfaces or onto electrical components can cause a fire.

Store all fuels and all lubricants in properly marked containers and away from all unauthorized persons.

Store oily rags and other flammable material in a protective container.

Do not smoke while you refuel the machine or while you are in a refueling area.

Do not smoke in battery charging areas or in areas that contain flammable material.

Clean all electrical connections and tighten all electrical connections. Check the electrical wires daily for wires that are loose or frayed. Tighten all loose electrical wires before you operate the machine. Repair all frayed electrical wires before you operate the machine.

Remove all flammable materials before they accumulate on the machine.

Do not weld on pipes or on tubes that contain flammable fluids. Do not flame cut on pipes or on tubes that contain flammable fluids. Before you weld on pipes or on tubes or before you flame cut on pipes or on tubes, clean the pipes or tubes thoroughly with a nonflammable solvent.



Figure 37

HDO1015I

# SHIPPING AND TRANSPORTATION

## Obey State and Local Over-the-Road Regulations















Check state and local restrictions regarding weight, width and length of a load before making any other preparation for transport.

The hauling vehicle, trailer and load must all be in compliance with local regulations governing the intended shipping route.

Partial disassembly or teardown of the excavator may be necessary to meet travel restrictions or particular conditions at the work site. See the Shop Manual for information on partial disassembly.



Refer to the Transportation and Shipping section of this Operation and Maintenance Manual for information on loading, unloading and towing.



A (m) B (m)	Chassis Frame Attachment	3		4		5		6		7		8		Max. Reach		
																A
0	R-Rear Dozer Only Up			8.96	4.82	6.34	3.57	4.88	2.81	3.94	2.30			*3.08	2.08	7.56
	R-Rear Dozer Only Down			8.76	6.59	6.20	4.78	4.76	3.72	3.85	3.02			*3.08	2.74	7.56
	R-Outrigger Only Down			8.48	10.47	5.99	7.22	4.61	5.48	3.72	4.40			*3.08	*3.08	7.56
	F-Dozer + R-Outrigger Down			*11.13	10.47	*8.90	7.22	*7.32	5.48	*6.29	4.40			*3.08	*3.08	7.56
-1	R-Rear Dozer Only Up	*7.07	*7.07	8.97	4.82	6.32	3.56	4.86	2.80	3.94	2.30			*3.32	2.22	7.23
	R-Rear Dozer Only Down	*7.07	*7.07	8.76	6.60	6.18	4.76	4.75	3.71	3.85	3.03			*3.32	2.91	7.23
	R-Outrigger Only Down	*7.07	*7.07	8.48	10.47	5.98	7.21	4.59	5.47	3.72	4.40			*3.32	*3.32	7.23
	F-Dozer + R-Outrigger Down	*7.07	*7.07	*11.57	10.47	*9.11	7.21	*7.49	5.47	*6.33	4.40			*3.32	*3.32	7.23
-2	R-Rear Dozer Only Up	*11.45	7.46	9.01	4.86	6.34	3.57	4.88	2.82					*3.70	2.46	6.73
	R-Rear Dozer Only Down	*11.45	10.67	8.80	6.63	6.20	4.78	4.77	3.73					*3.70	3.23	6.73
	R-Outrigger Only Down	*11.45	*11.45	8.52	10.51	6.00	7.23	4.61	5.49					*3.70	*3.70	6.73
	F-Dozer + R-Outrigger Down	*11.45	*11.45	*11.29	10.51	*9.00	7.23	*7.37	5.49					*3.70	*3.70	6.73

### 3. Quick Coupler Switch (Optional)

Clamp releasing for dispensable attachment is controlled.

- O. In this position , the quick coupler is "LOCKED". The attachment is secured to the arm.
- I. In this position , the quick coupler is "UNLOCKED". The attachment is released from the arm.

**NOTE:** To move the switch, pull up on the toggle and then move it into "UNLOCKED" position.

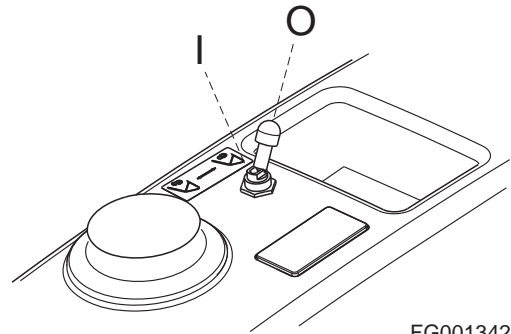

FG001342

Figure 6



## WARNING

### AVOID DEATH OR SERIOUS INJURY

When the attachment is still connected to the machine, while the switch is "I" () position, do not operate the machine or the attachment might fall to the ground. It would cause personnel injuries.

### 4. Auxiliary Mode Switch

When the control system is out of order, the pump system can be controlled manually.

- O. In this position, the manual pump control is "OFF".
- I. In this position, the manual pump control is "ON".



## CAUTION

### AVOID INJURY

Be sure to turn pump control to "O" (OFF) position, after the control system is operating properly.

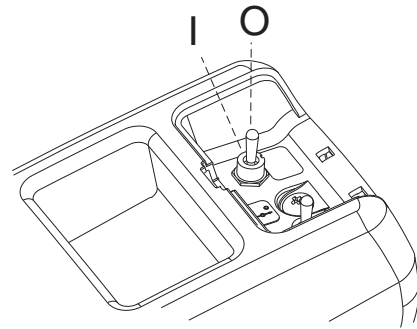

FG001343

Figure 7

### 5. Engine Emergency Stop Switch

If the engine does not stop when using the starter switch, it can be stopped by moving the engine emergency stop switch to "I" (EMERGENCY STOP) position.

- O. In this position, the engine emergency stop system is "OFF".
- I. In this position, "EMERGENCY STOP" is selected. The engine will stop.

**NOTE:** When released, the switch will return to its original position "O" (OFF) position.

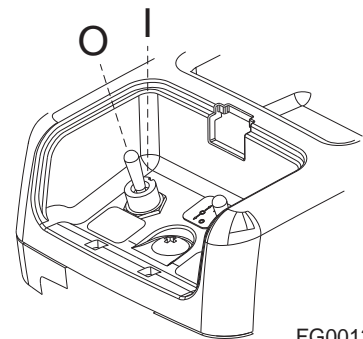

FG001344

Figure 8

## 29. Photo Sensor

The photo sensor detects the radiant energy of the sun.

In auto mode the air conditioner will automatically adjust the air temperature based on to the detected radiant energy.

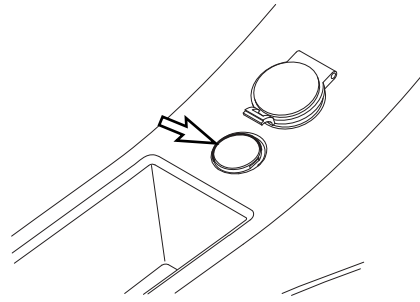

FG000399

**Figure 36**

## 10. Engine Check Warning

This symbol indicates when the engine needs to be checked.

**NOTE:** *If this symbol turns "ON" stop the machine and repair the cause of the fault.*

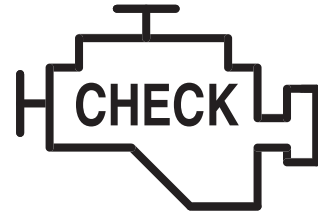

FG000045

Figure 58

## 11. Preheating Indicator

In cold weather this symbol indicates that engine preheat function is operating.

When this indicator symbol turns "OFF", it means that engine preheat cycle has been completed.

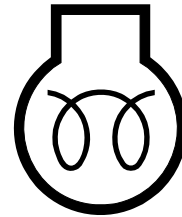

HAAE2000

Figure 59

## 12. Work Light Indicator

The indicator symbol indicates that work lights are turned "ON".



HB4O2003

Figure 60

# SETTING MAIN MENU

By using a combination of the selector buttons (Figure 86), you can review and set the contents of the display screen. Items such as language, time and filter/oil information can be checked, and if necessary, set with new information.

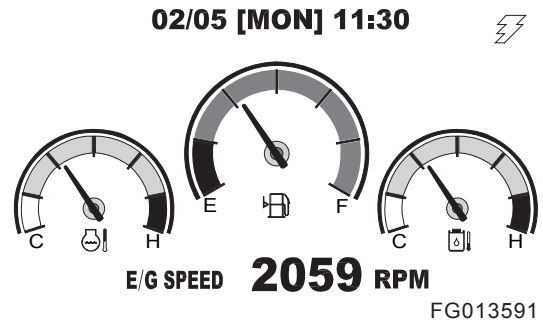
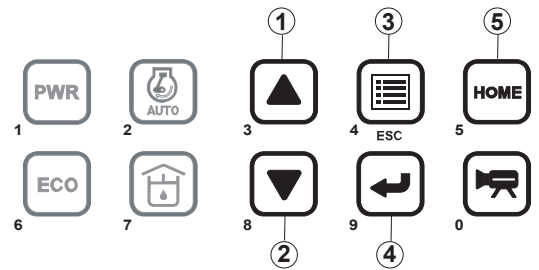

Figure 85



FG013712

Figure 86

## 1. Up Arrow Button

Up arrow button (▲), is used to move a menu item "Up" or to "Left".



FG000068

Figure 87

## 2. Down Arrow Button

Down arrow button (▼), is used to move a menu item "Down" or to "Right".



FG013897

Figure 88

## Adjusting Flow Rate

Use "UP" (▲) or "DOWN" (▼) buttons to adjust flow rate.

"UP" (▲) button is used to increase a flow rate.

"DOWN" (▼) button is used to decrease a flow rate.

Flow Control Step	Pump Flow Setting (l/min)
0	23
1	40
2	60
3	79
4	88
5	98
6	119
7	130
8	144
9	158
10	158

Pump flow setting is at rated engine speed, for only the output of one pump.

Pump displacement will vary according to changes in engine rpm.

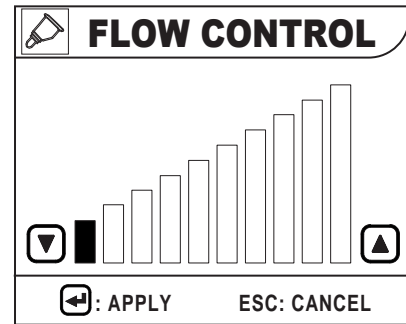

FG014885

Figure 113 Breaker

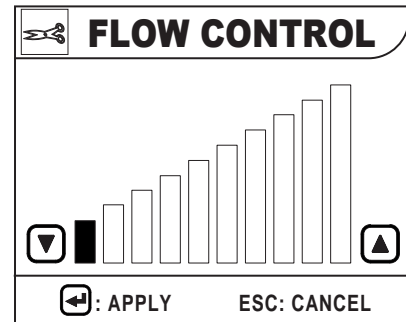

FG014886

Figure 114 Shear

## Escape

- A. Press flow control button (⏏), Figure 111) to return to normal display screen and save the flow rate setting.
- B. If there is no adjustment for twenty seconds, the flow control screen will return to the normal display screen.

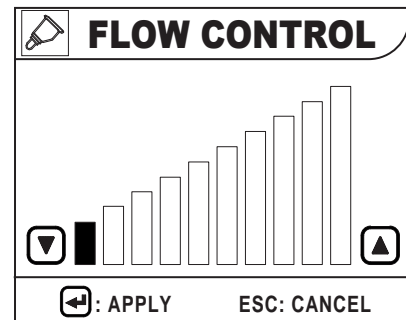

FG014885

Figure 115

# STEREO

Before operating the stereo or CD player, read operation manual enclosed with stereo.

## Stereo

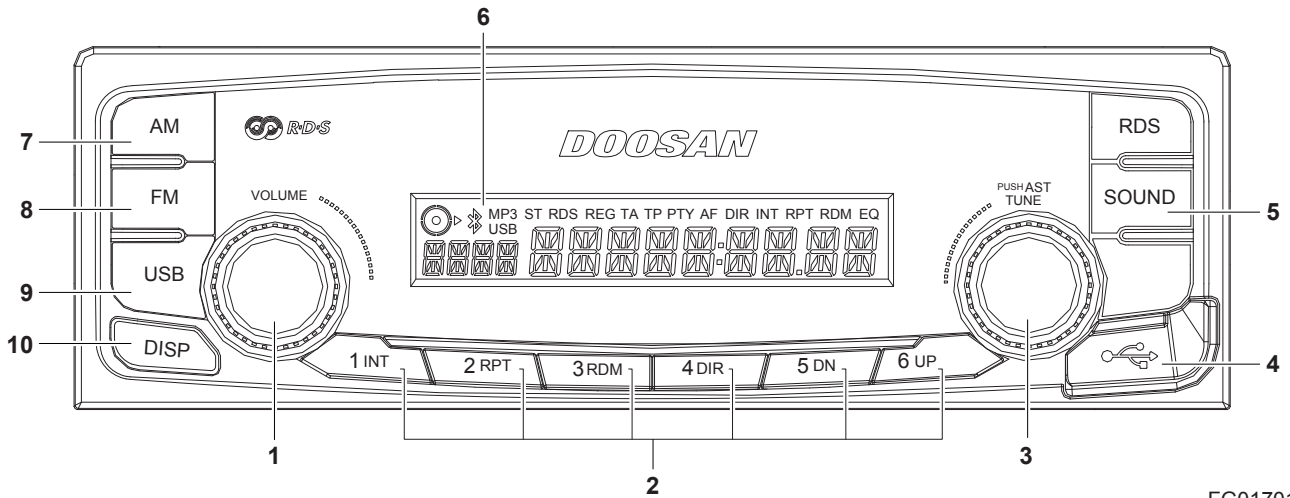

FG017016

Figure 143

Reference Number	Description
1	Power/Volume Control
2	Preset Station
3	Tuning Up/Down
4	USB Loading Port
5	Sound Mode Selector

Reference Number	Description
6	LCD
7	AM Selection
8	FM Selection
9	USB Selection
10	Display Mode Control

## CD Player (Optional)

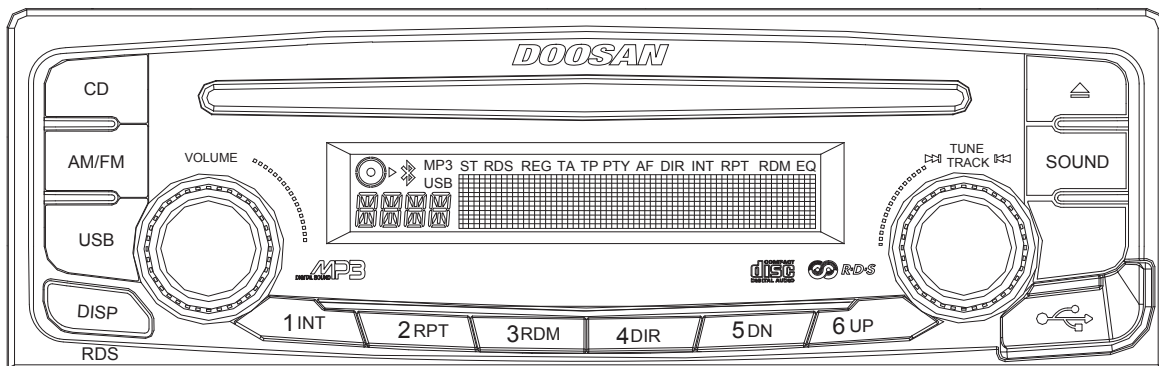

FG017017

Figure 144

## DOOR SIDE LATCH

1. The door side latch (1, Figure 164) is used to secured door to side of cabin when it is opened.

**NOTE:** *Keep door closed and locked when machine is not in use.*

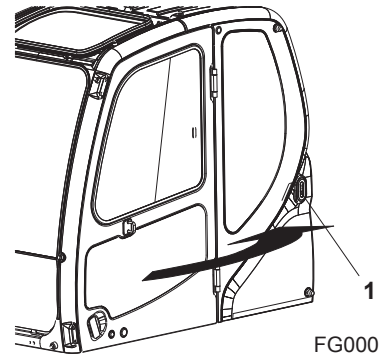

FG000196

**Figure 164**

2. To release door from side of cabin, push latch lever (2, Figure 165) down. The latch lever is to the left of operator's seat.

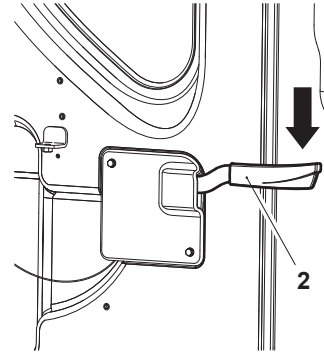

FG000673

**Figure 165**

CLICK HERE TO **DOWNLOAD** THE COMPLETE MANUAL

- Thank you very much for reading the preview of the manual.
- You can download the complete manual from: [www.heydownloads.com](http://www.heydownloads.com) by clicking the link below



- Please note: If there is no response to CLICKING the link, please download this PDF first and then click on it.

CLICK HERE TO **DOWNLOAD** THE COMPLETE MANUAL

# Operational Checks Before Starting Engine

## **WARNING**

### **AVOID DEATH OR SERIOUS INJURY**

When leaving operator's seat, set the safety lever and stand on "LOCK" (Figure 1) position, if not a serious accident could occur by accidentally moving the travel or work levers.

1. Move safety lever and stand to "LOCK" position (Figure 1).
2. Fasten seat belt. Check for proper operation and condition.
3. Set all operation levers in "NEUTRAL".

**NOTE:** *Be careful not to touch any switches when starting engine.*

4. Set parking brake switch to "I" position. This will ensure that the parking brake is "APPLIED".

5. Rotate the starter switch to "I" (ON) position (Figure 4). Check all indicator lights. A warning buzzer will sound for about 2 seconds. After 2 seconds, all lights except the following will turn "OFF".

- Engine coolant temperature gauge
- Charging warning light
- Fuel gauge
- Hydraulic oil temperature gauge
- Engine oil pressure warning light
- Engine rpm (0 rpm) digital readout

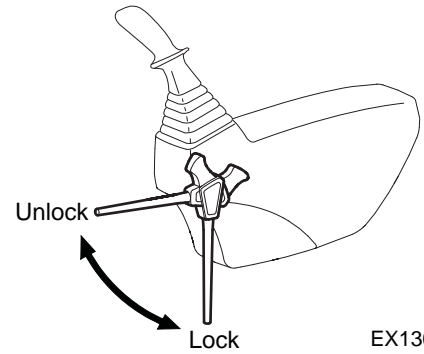

EX1300566

**Figure 1**

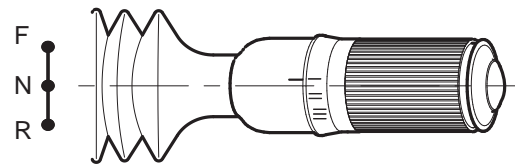

FG002266

**Figure 2**

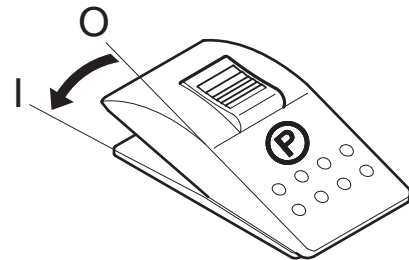

FG002178

**Figure 3**

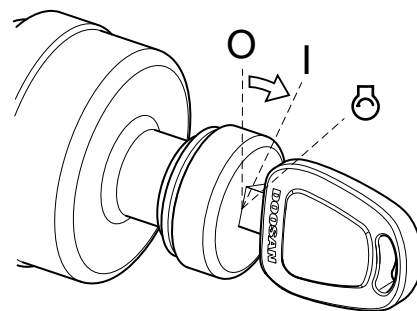

FG000084

**Figure 4**

5. Stop engine by turning key to "O" (OFF) position (Figure 27).
6. Remove key from starter switch.

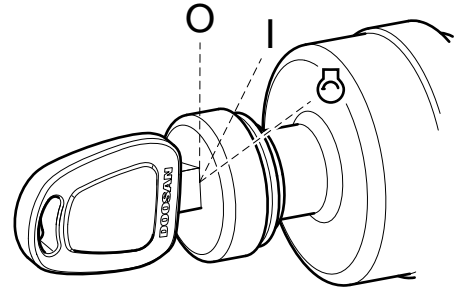

FG000175

Figure 27

## Check and Confirmation After Stopping Engine

1. Repair excavator, if there are any coolant or oil leaks.
2. Inspect front attachment and chassis frame for abnormal appearances. Correct any problems.
3. Fill fuel tank.
4. Get rid of any accumulated flammable materials such as leaves and paper etc. in engine compartment.
5. Clean all mud, etc. from chassis frame and tires. Make sure that all steps and hand holds are clean, and that operator's cabin is clean.

# OPERATING INSTRUCTIONS

## Engine Speed Control

Engine speed can be manually adjusted using the engine speed control dial. Increase engine speed by rotating the control knob clockwise. Decrease engine speed by rotating the control knob counterclockwise.

---

### IMPORTANT

---

The engine speed control system has been set at the factory and should not require adjustment as part of routine maintenance.

---

In the event that the automatic speed control system fails, the EPOS controls automatically defaults and reduces engine speed. Manual control of engine speed can be done by using either the manual engine speed control dial, which will allow the operator to set and hold a specific engine speed, or the Accelerator Pedal for variable engine speed.

**NOTE:** *If the automatic speed control system has failed, the EPOS controls automatically defaults and the machine will not function at full rated capacity.*

---

### IMPORTANT

---

If the engine rpm is being manually adjusted, the equipment will not function in its optimum capacity. Please contact a DOOSAN distributor or service center for repairs.

---

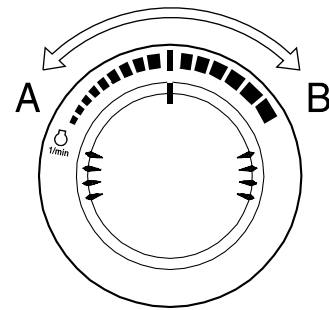

HAOA690L

Figure 45

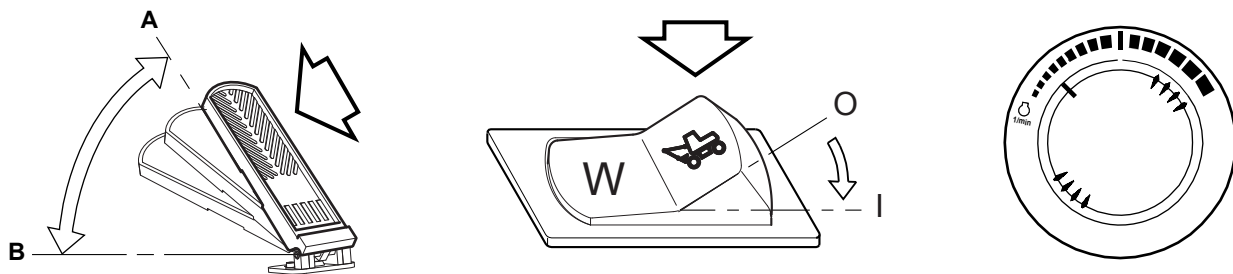

FG002663

Figure 46

Engine speed can be controlled by either the manual accelerator pedal or the manual speed control dial.

With the travel/work mode selector switch in the "TRAVEL MODE" position, all hydraulic controls are locked out.

15. Do not dig with the excavator tires raised. This can result in structural and mechanical failures.
16. Do not operate travel lever quickly when traveling in high range.
  - Avoid sudden starts.
  - When traveling in one direction come to a complete stop before reversing directions. Do not rock excavator back and forth with levers.
  - Avoid sudden stops. Return levers to neutral by hand. Do not let them snap back to neutral on their own.
17. If the optional long fronts or attachments or heavy duty front end attachments are used, the machine balance will be altered. Follow these additional operating precautions.

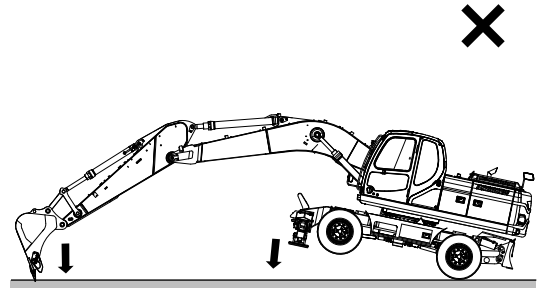

FG006576

Figure 72



## WARNING

### AVOID DEATH OR SERIOUS INJURY

Do not travel downhill with the front end attachments raised.

Do not travel across slopes; travel straight up or downslope.

Use extreme caution when swinging the upper frame when positioned on a slope.

Allow extra swing stopping room. The additional momentum generated by the longer or heavier front end equipment will increase the amount of time needed to stop the swing motion.

Make sure that all optional equipment has been authorized and installed properly.

18. Do not move dirt or objects by swinging the excavator into them. This can result in structural and mechanical failures.



## DANGER

### AVOID DEATH

When lifting the lower structure, place the round bottom of the bucket on the ground and place the arm and boom so that the angle between them are 90° - 110°.

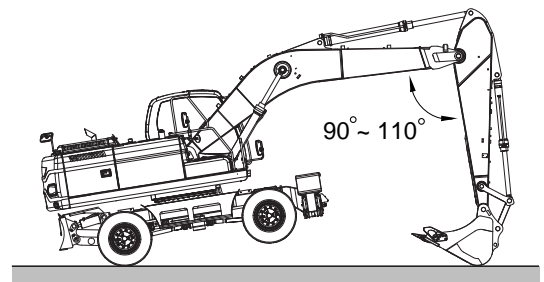

FG006577

Figure 73

# ADJUSTING THE PUMP FLOW

**NOTE:** For further information, see "Flow Control" on page 2-48.

1. On the instrument panel, press the flow control button , the flow control screen (Figure 92) will be displayed.
2. Use "UP" (▲) or "DOWN" (▼) buttons to adjust flow rate.
3. Press "SELECT" (◀) button, to return to normal display screen and save the flow rate setting.

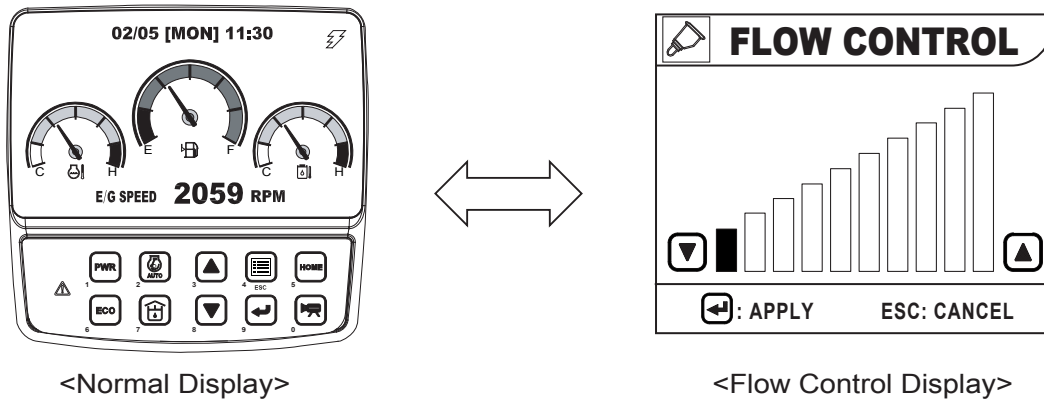

FG013831

**Figure 92**

Flow Control Step	Pump Flow Setting (l/min)
0	23
1	40
2	60
3	79
4	88
5	98
6	119
7	130
8	144
9	158
10	158

# Inspection, Maintenance and Adjustment

## PREVENTIVE MAINTENANCE

Routine maintenance and inspections are required to keep your machine in the correct operating condition. The following pages list the inspection intervals, the system or component checks, and location references.

**NOTE:** *The following pages list the service checks and their required intervals. The service cycles may need to be shortened depending on the working conditions. Extremely hot or dusty conditions will require more frequent service. Operational hours are determined by the amount of time accumulated on the engine hour meter on the control console in the cabin.*

**NOTE:** *Besides the normal hour meter, the multifunction gauge can be used to keep track of the hours on individual filters. See "Filter/Oil Info" on page 2-43.*

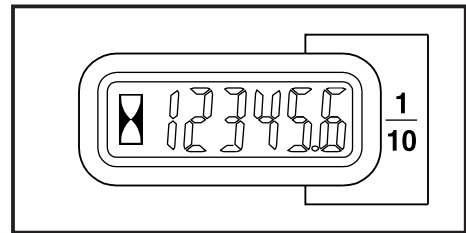

HAOA601L

Figure 1

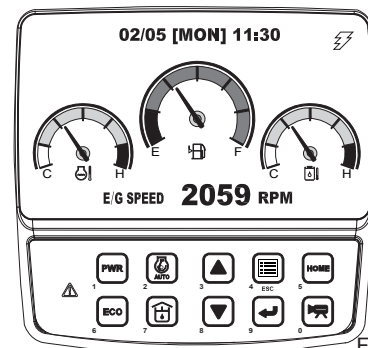















FG013662

Figure 2

# LUBRICATION AND SERVICE CHART

Lubrication and service chart is on the inside of battery box cover. The symbols shown here are used in the lubrication and service chart on the next page.

Symbol	Description
	Lubrication
	Gear Oil (Swing Device, Travel Device)
	Engine Oil
	Engine Oil Filter
	Hydraulic Oil
	Hydraulic Oil Return Filter
	Hydraulic Oil Tank Breather

Symbol	Description
	Coolant
	Air Cleaner Element
	Fuel Filter
	Air Conditioner Filter
	Drain Water
	Gear Oil (Axle)
	Fuel Cap Filter

## Check for Leaks in Hydraulic System

1. Perform a daily walk-around inspection to make sure that hoses, piping, fittings, cylinders and hydraulic motors are not showing any signs of leakage. If any is noted, determine the source of the leak and repair.

## Check Fuel Level



**AVOID DEATH OR SERIOUS INJURY**

Use extreme safety precautions while refueling to prevent explosions or fire.

Immediately clean up any split fuel.

---

1. At end of each work day, fill fuel tank. Add fuel through fuel fill tube (1, Figure 20). When working at a temperature of 0°C (32°F) or higher, use ASTM No. 2-D or its equivalent. At temperatures below 0°C (32°F) use ASTM No. 1-D or its equivalent.
2. Make sure that fuel fill hose is grounded to the excavator before fueling begins.
3. Check the amount of fuel in the tank by observing the fuel tank sight gauge (2, Figure 20) and fuel gauge in monitor panel. Fill the tank using the fill tube with the proper fuel for the operating conditions.

**NOTE:** See "Fluid Capacities" on page 4-10. for capacity.

4. The excavator may be equipped with the optional battery operated fuel fill pump. The pump assembly is located in the battery box. Put the suction hose of the pump into the fuel resupply tank. Turn the switch in the battery box "ON", and the fuel will be pumped into the excavator fuel tank.
5. Do not overfill the tank.
6. Securely tighten cap after fueling.

**NOTE:** If breather holes in cap are clogged, a vacuum may form in the tank preventing proper fuel flow to engine. Keep holes in fuel cap clean.

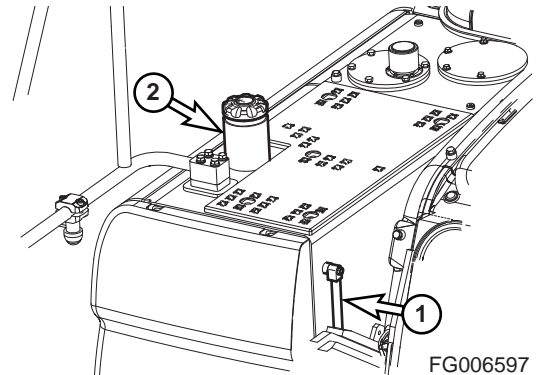

Figure 20

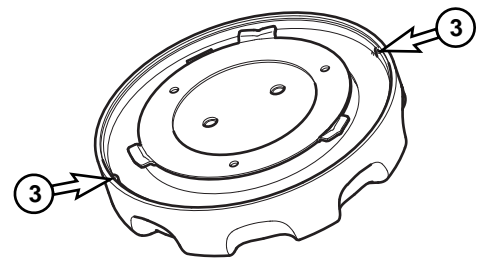

Figure 21

## Grease Dozer Blade Pin

**NOTE:** Grease it per 10 hours during initial period of 100 hours after buying your new vehicle, after which period grease it per 50 hours.

**NOTE:** In case of performing work underwater, grease it per 10 hours irrespective of elapsed period.

1. Remove chain connecting between dozer cylinder protection cover and chassis frame out of this chassis frame.
2. Completely open the dozer cylinder protection cover.
3. Inject grease at total 10 points by 5 points per dozer cylinder by means of using grease gun.
4. Neatly remove old grease that has leaked out after greasing.
5. Shut dozer cylinder protection cover after finishing greasing and then connect the chain to the chassis frame.



### CAUTION

#### AVOID INJURY

In order to avoid malfunction when opening dozer cylinder protection cover, you must work it after fixing the facilities on a planar ground surface and then putting down the dozer blade. When opening dozer cylinder protection cover, take heed so that the cover would not be shut off by external shock etc.

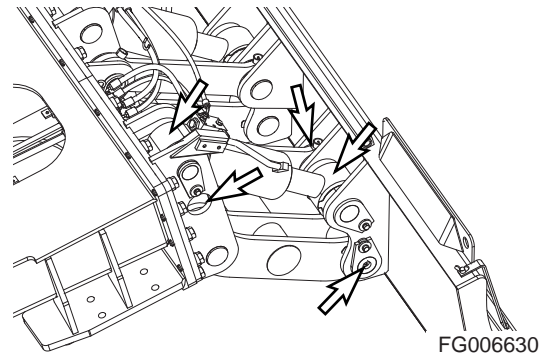

Figure 40

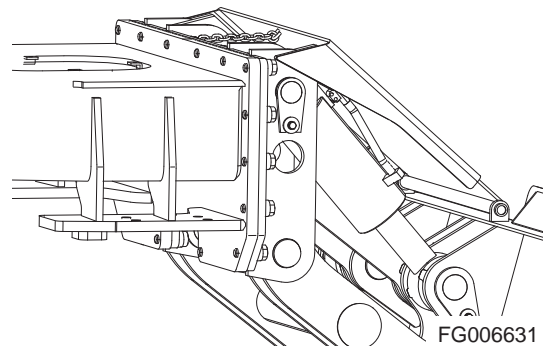

Figure 41

## Grease Outrigger Pins

Grease every 10 hours for first 100 hours and every 50 hours thereafter.

**NOTE:** If the unit has been running or working in water the outrigger must be greased on a 10 hour/daily basis.

- Position machine as shown Figure 42 and lower the outrigger leg to the ground and stop engine.
- Press the grease fitting and inject grease with the grease gun on the marked points.
- There are a total of 8 grease points, 4 on each cylinder of the outrigger.
- After injection, clean off the old grease that has been purged.

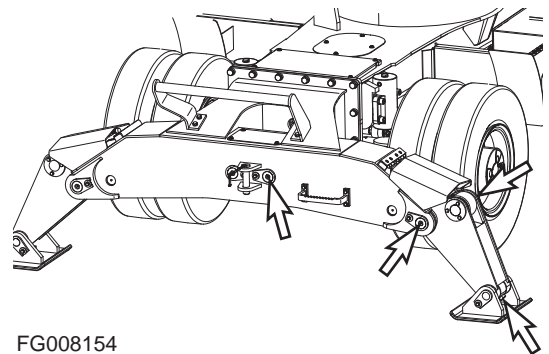

Figure 42

## Clean Air-Conditioning Outer Filter

The unit is equipped with an air filtration system which filters out dirt and dust particles from air being circulated into operator's cabin. This filter must be cleaned out.

**NOTE:** *If the unit is being operated in a dusty environment, the cleaning and replacement must be performed more frequently. If filter is damaged, replace damaged filter with a new one.*



### WARNING

---

#### AVOID DEATH OR SERIOUS INJURY

All service and inspection of air-conditioning system must be performed with the starter switch in the "O" (OFF) position.

---

---



### WARNING

---

#### AVOID DEATH OR SERIOUS INJURY

If using compressed air to clean the element, make sure that proper eye protection is worn.

---

---

**NOTE:** *All right and left call outs are based on the operator being seated in the operator's seat facing the front.*

1. Open the door in the left front of the machine, then remove the cover (1, Figure 59) by loosening the four wing bolts.
2. Open the cover by turning the knob (1, Figure 60) in the rear of the cabin.

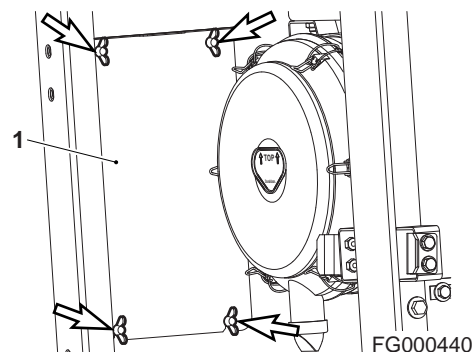

Figure 59

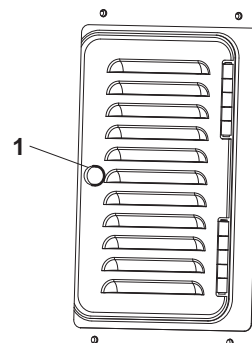
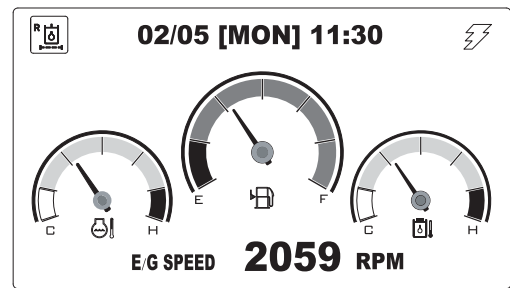

Figure 60

## Replace Hydraulic Oil Return Filter

**NOTE:** Change hydraulic oil return filter after first 250 hours of operation or rebuild, and every 1,000 hours thereafter.

**NOTE:** If return filter clogged warning light (Figure 84) on instrument panel comes "ON" the return filter must be serviced.



FG013832

Figure 84

## WARNING

### AVOID DEATH OR SERIOUS INJURY

The hydraulic oil will be hot after normal machine operation. Allow the system to cool before attempting to service any of the hydraulic components.

The hydraulic tank is pressurized. Loosen the hydraulic breather cap slightly to allow the pressurized air to vent. After the pressure has been released, it is safe to remove either the breather cap or service covers or drain water from the tank.

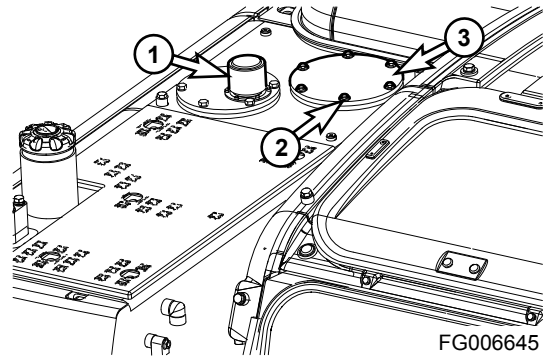

FG006645

Figure 85

## IMPORTANT

Make sure to clean any dirt or water from the top of the hydraulic tank, especially around the fill port and filter ports.

1. Park machine on firm and level ground. Lower the front attachment to the ground and stop engine.
2. Loosen the breather cap (1, Figure 85) slightly to release the internal pressure.
3. Remove bolts (2, Figure 85) and service cover (3). Remove spring (4), valve (5) O-ring (6), and bypass strainer (7), and then filter (8).

4. Remove filter and discard.

**NOTE:** Used filter should always be disposed of according to local regulations.

5. Install new filter and a new O-ring. Install bypass strainer, valve and spring. Install service cover plate.
6. Tighten the breather cap (1, Figure 85).
7. Run engine for ten minutes at low idle to purge air from circuit.
8. Check level in hydraulic oil tank (See page 4-19). Add oil if necessary.

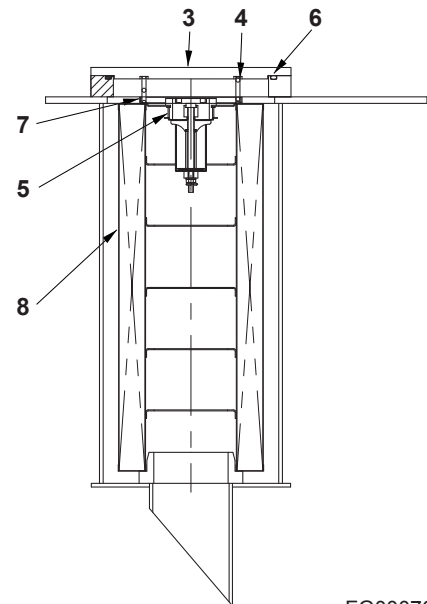

FG000761

Figure 86

3. Remove coolant drain plug (1, Figure 112) from engine.
4. Install drain plug, and close drain valve after coolant has completely drained from system.
5. Fill cooling system with a flushing solution.
6. Run engine at low idle until the coolant temperature gauge reaches the "BLUE ZONE". Run engine for another ten minutes.
7. Allow engine to cool.
8. Drain flushing fluid and fill system with water.
9. Run engine again to allow water to completely circulate.
10. After allowing engine to cool, drain water and fill system with proper antifreeze mixture for ambient temperature. Refer to coolant concentration table. See "Antifreeze Concentration Tables" on page 4-86.
11. Run engine without radiator cap installed, so all air will be purged from system. Fill radiator to fill neck.
12. Drain and fill radiator coolant recovery tank.



ARO1760L

Figure 111

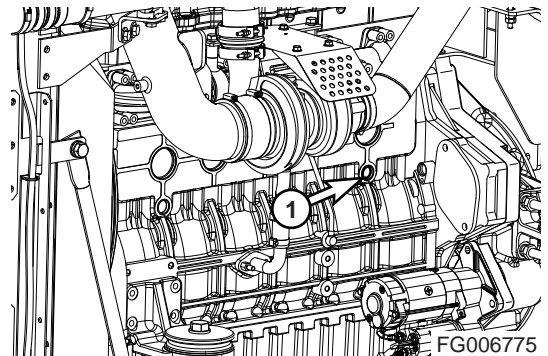

FG006775

Figure 112

## Hydraulic Oil Exchange and Suction Strainer Cleaning



### WARNING

#### AVOID DEATH OR SERIOUS INJURY

The hydraulic oil will be hot after normal machine operation. Allow the system to cool before attempting to service any of the hydraulic components.

The hydraulic tank is pressurized. Loosen the breather cap to allow the pressurized air to vent. After the pressure has been released, it is safe to remove either the fill cap or service covers.



ARO1760L

Figure 113

### IMPORTANT

Make sure to clean any dirt or water from the top of the hydraulic tank, especially around the fill port and filter ports.

Hydraulic oil change interval is 2,000 hours, only when DOOSAN Genuine Oil is used. If another brand of oil is used, guaranteed change interval is 1,000 hours.

1. Joint Bolt with Engine Mounting Bracket and Engine

1) Pump Side

- Tool: 24 mm (🔧)
- Torque: 27 kg•m

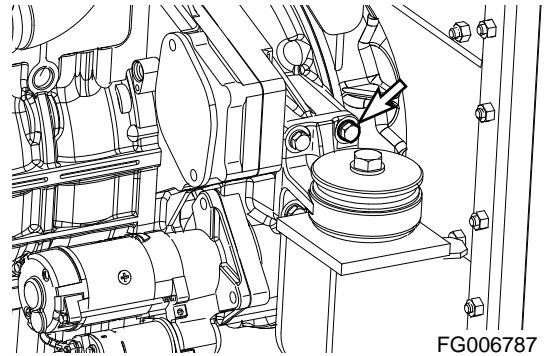

Figure 123

2) Fan Side

- Tool: 17 mm (🔧)
- Torque: 6.5 kg•m

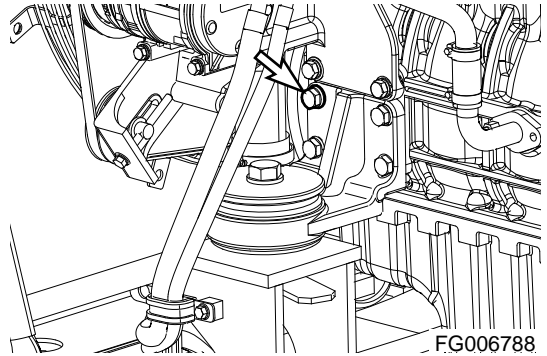

Figure 124

2. Joint Bolt & Nut Between Engine Mounting Bracket and Frame

1) Pump Side

- Tool: 30 mm (🔧)
- Torque: 46 kg•m

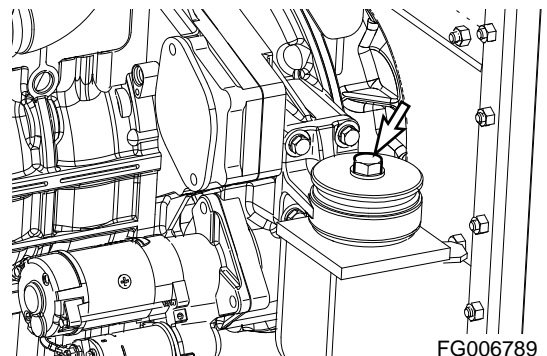

Figure 125

2) Fan Side

- Tool: 30 mm (🔧)
- Torque: 46 kg•m

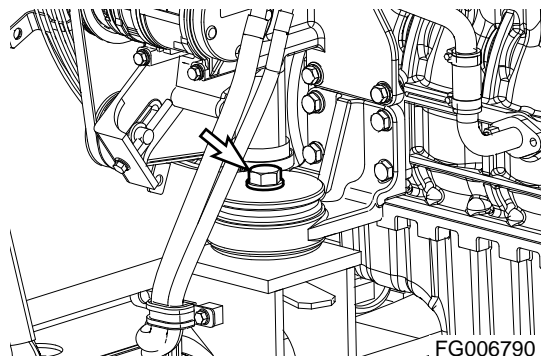
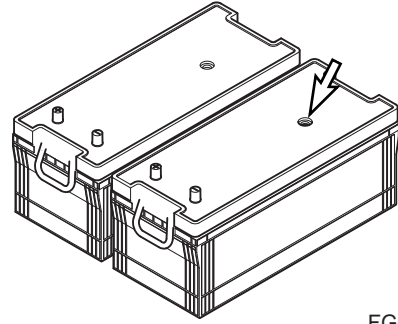

Figure 126

## Inspection of Battery Electrolyte Level

This machine has two maintenance free batteries. They never require the addition to water.

When the charge indicator becomes transparency, it means low electrolyte state because of the leakage or charging system error. Determine the cause of problem and replace the batteries immediately.



FG000347

Figure 155

## Check Charging State

Check charging state through the charging indicator.

- GREEN: Sufficiently charged.
- BLACK: Insufficient charged.
- TRANSPARENT: Replace battery.

## Check the Battery Terminals

Be certain that the battery is held securely in its compartment. Clean the battery terminals and the battery cable connectors. A solution of baking soda and water will neutralize acid on the battery surface, terminals, and cable connectors. Petroleum jelly or grease can be applied to the connectors to help prevent corrosion.

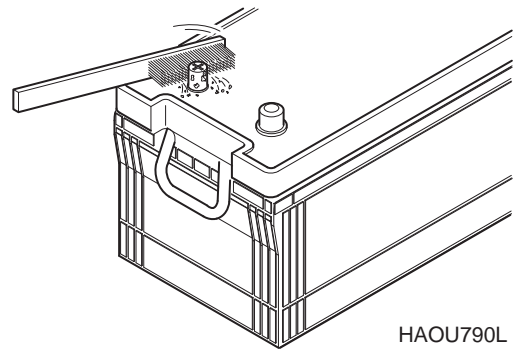

HAOU790L

Figure 156

## Battery Replacement

When the charging indicator indicates transparency state, replace the battery. The batteries should always be replaced in pairs.

Using an old battery with a new one will shorten the life span of the new battery.

# Brake Accumulator

## Release Brake Accumulator Pressure

Using the following procedure;

1. Position the machine on firm and level ground.  
Lower the front attachment to the ground.
2. Set parking brake switch to "I" position.  
This will ensure that the parking brake is "APPLIED".
3. Move safety lever and stand to "LOCK" position.
4. stop engine.
5. Wheel chock is installed under the tires to secure the machine.
6. Release the brake line pressure by stepping on the service brake pedal several times.
7. Open the left door of the machine.
8. Remove accumulator by unscrewing it slowly.

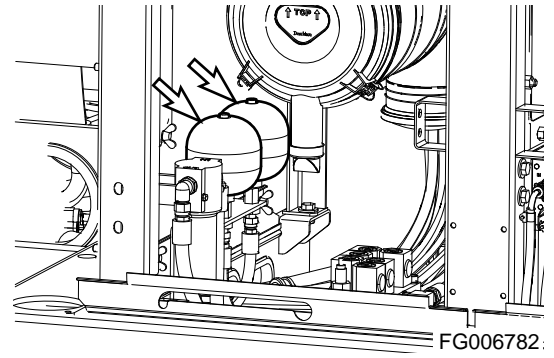

**Figure 163**

# LONG TERM STORAGE

Perform the following if storing the excavator for more than one month.

Conditions	Maintenance Required
Cleaning	Pressure wash the undercarriage and track assemblies. Inspect for damage or loose or missing parts.
Lubrication	Perform all daily lubrication procedures.
	Apply a coating of light oil to the exposed plated metal surfaces, such as hydraulic cylinder rods, etc.
	Apply a coating of light oil to all of the control linkages and control cylinders (control valve spools, etc.).
Battery	Remove the battery from the excavator or remove the battery leads from the battery to fully charge and store.
Cooling System	Inspect the coolant recovery tank to make sure that the antifreeze level in the system is at the correct level.
	Every 90 days, use a hydrometer to measure the protection level of the coolant. Refer to the antifreeze/coolant protection chart to determine the amount of protection the cooling system requires. Add coolant as required.
Hydraulic System	Once a month, start the engine and follow the "Hydraulic Oil Warm-up" procedures listed in this manual.

# HYDRAULIC SYSTEM

<b>Problem</b>	<b>Cause</b>	<b>Remedy</b>
None of the controls function (loud noise from pumps)	Hydraulic pump failure.	Contact your DOOSAN dealer.
	Low hydraulic oil level.	Add hydraulic oil as required.
	Suction line clogged or damaged.	Clean or replace as required.
None of the controls function (no noise from pumps)	Pilot pump failure.	Contact your DOOSAN dealer.
	Cut off solenoid valve failure.	Replace solenoid.
	Safety limit switch is "ON".	Adjust limit switch clearance.
	"WORK/TRAVEL" selector switch is "TRAVEL" mode.	Select "Work Mode"
All actuators have low power	Low hydraulic oil level.	Add hydraulic oil as required.
	Suction filter clogged.	Clean filter.
	Hydraulic pumps faulty.	Contact your DOOSAN dealer.
	Main relief pressure too low.	Contact your DOOSAN dealer.
	Hydraulic pumps excavating.	Bleed air from hydraulic pumps.
Only one or two actions have little or no power	Overload relief pressure too low.	Reset pressure.
	Makeup check valve leaking.	Clean or replace as required.
	Control valve spool faulty.	Replace valve spool.
	Dirt in valve spool.	Clean or replace as required.
	Actuator failure.	Repair or replace as required.
	Cylinder seal failure.	Repair or replace as required.
	Cylinder rod damaged.	Repair or replace as required.
	Remote control valve failure.	Replace control valve.
	Wrong pilot line connection.	Reconnect pilot lines.
Oil temperature too high	Oil cooler faulty.	Contact your DOOSAN dealer.
	Fan belt loose.	Tighten fan belting as required.

CLICK HERE TO **DOWNLOAD** THE COMPLETE MANUAL

- Thank you very much for reading the preview of the manual.
- You can download the complete manual from: [www.heydownloads.com](http://www.heydownloads.com) by clicking the link below



- Please note: If there is no response to CLICKING the link, please download this PDF first and then click on it.

CLICK HERE TO **DOWNLOAD** THE COMPLETE MANUAL