

Flat-Deck Trailers

Operator's Manual



CLICK HERE TO **DOWNLOAD** THE COMPLETE MANUAL

- Thank you very much for reading the preview of the manual.
- You can download the complete manual from: www.heydownloads.com by clicking the link below



- Please note: If there is no response to CLICKING the link, please download this PDF first and then click on it.

CLICK HERE TO **DOWNLOAD** THE COMPLETE MANUAL

Safety Alerts



⚠ WARNING Crushing weight could cause death or serious injury. Use proper procedures and equipment or stay away.

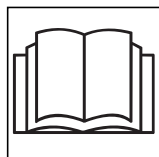

⚠ WARNING Incorrect procedures could result in death, injury, or property damage. Learn to use equipment correctly.

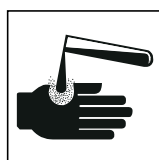

⚠ CAUTION Battery acid may cause burns. Avoid contact.

Service

IMPORTANT: Consult with brake, axle, and tire manufacturers for additional service information.

Each Use

Task	Notes
Check tire pressure and lug nut torque	
Check lights and reflectors	
Check battery charge	electric brakes only
Check hydraulic brake fluid	hydraulic brakes only DOT 3 or DOT 4
Check actuator bolts	
Check coupler bolts	
Check suspension bolts	
Check tiedown binders and chains	

Check Tire Pressure

Check tire pressure each use where shown.
Inflate tires as indicated.

Tire	Pressure
18 X 5.70-8, C	75 psi (517 kPa)
215/75R-17.5, H16TL	125 psi (862 kPa)
ST205/75R15, C	50 psi (345 kPa)
ST225/75R15, D	65 psi (448 kPa)
ST235/80R16, E	80 psi (551.5 kPa)
ST235/85R16, E	80 psi (551.5 kPa)
ST235/85R16, F	95 psi (655 kPa)

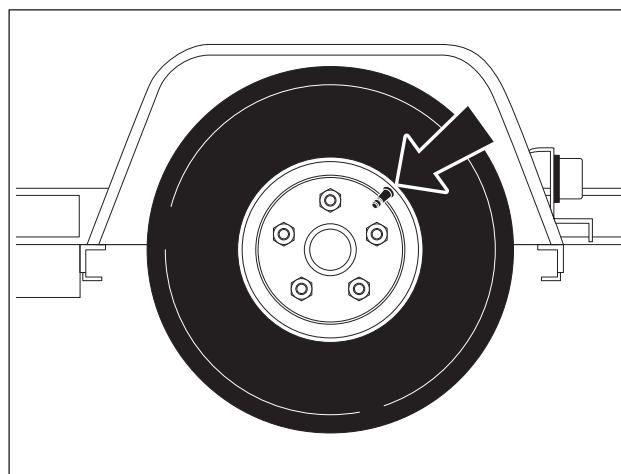

a320m005t.eps

6000 Mile (10 000 km)

Check Brake Controller Amperage

Check brake controller amperage every 6000 miles (10 000 km).

1. Disconnect black wire from trailer connector plug.
2. Attach 0-30A ammeter in line between black wire and connector plug.
3. Start tow vehicle and connect trailer plug to tow vehicle receptacle.
4. Set brake controller to maximum gain (trailer brakes applied fully).
5. Read ammeter. Recommended readings depend on number of axles and brakes.:
 - Single-axle trailer with two brakes: 6A.
 - Tandem-axle trailer with four brakes: 12A.

IMPORTANT: Voltage readings at each brake magnet should be at least 10.5V.

If amp reading is high, check for electrical short in the following areas:

- brake magnet coils
- controllers
- bare wires

If amp reading is low, check for the following:

- blown fuses
- broken wires
- poor connections and grounds

S6B

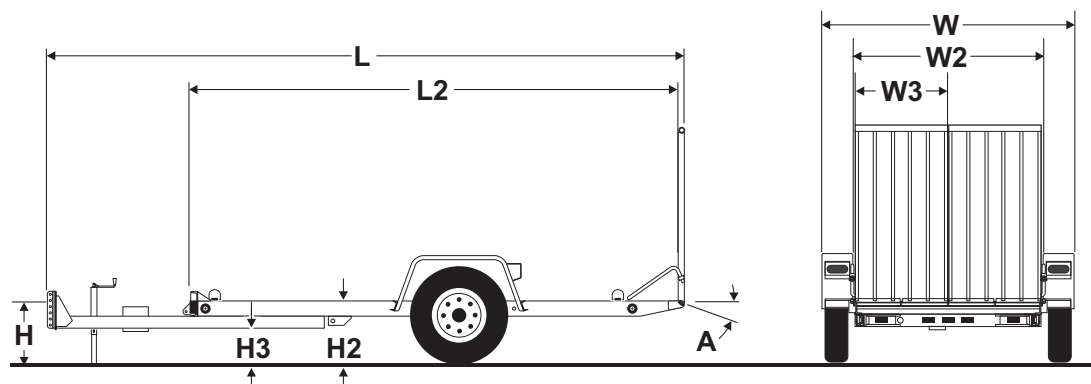

a32om016t.eps

Dimensions		U.S.	Metric
L	Total length	216 in	5.5 m
L2	Bed length	156 in	4.0 m
H	Adj. coupler heights	16-22 in	406-559 mm
H2	Bed height (at full load)	20 in	508 mm
H3	Clearance	8 in	203 mm
W	Width outside fenders	82 in	2.1 m
W2	Width between fenders	62 in	1.6 mm
W3	Width of ramp (each)	30 in	762 mm
A	Loading angle	18°	18°

General

Axle: 1, Dexter, #12 Torflex, rubber torsion suspension axle, 7000 lb rating

Available couplers: 3" (76-mm) lunette or 2 5/16" (59-mm) ball

Brakes: 12" x 2" electric

Electrical system: 12V D.C.

Safety chain size: 3/8" (9.6 mm) grade 70

T9C

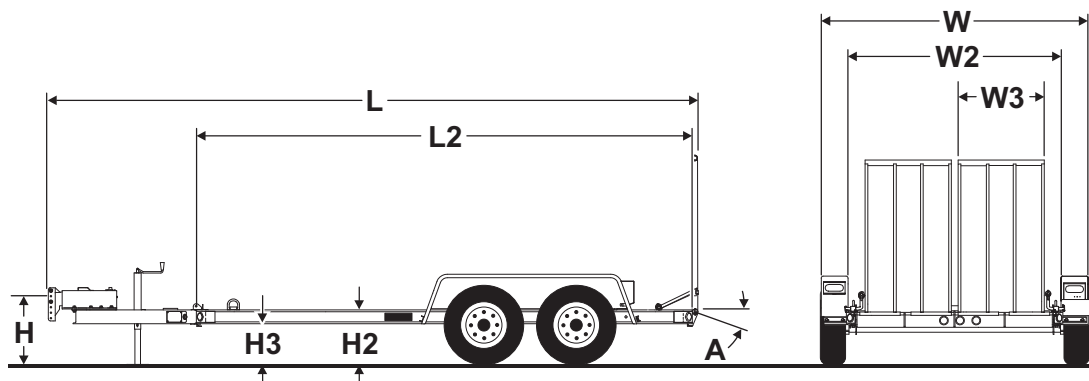

a32om021t.eps

Dimensions		U.S.	Metric
L	Total length		
	T9CE	223 in	5.7 m
	T9CH	229 in	5.8 m
L2	Bed length	154 in	3.9 m
H	Adj. coupler heights	17-25 in	432-635 mm
H2	Bed height (at full load)	18 in	457 mm
H3	Clearance	10.5 in	267 mm
W	Width outside fenders	96 in	2.4 m
W2	Width between fenders	76 in	1.9 m
W3	Width of each loading ramp	30 in	762 mm
A	Loading angle	18°	18°

General	
Axle: 2, Dexter, #11 Torflex, rubber torsion suspension axle, 6000 lb rating	
Available couplers: 3" (76-mm) lunette or 2 5/16" (59-mm) ball	
Brakes: 12" X 2" electric or hydraulic	
Electrical system: 12V D.C.	
Safety chain size: 3/8" (9.6 mm) grade 70	

Warranty

Ditch Witch® Equipment and Replacement Parts Limited Warranty Policy

Subject to the limitation and exclusions herein, free replacement parts will be provided at any authorized Ditch Witch dealership for any Ditch Witch equipment or parts manufactured by The Charles Machine Works, Inc. (CMW) that fail due to a defect in material or workmanship within one (1) year of first commercial use (Exception: 2 years for all SK5 attachments). Free labor will be provided at any authorized Ditch Witch dealership for installation of parts under this warranty during the first year following "initial commercial" use of the serial-numbered Ditch Witch equipment on which it is installed. The customer is responsible for transporting their equipment to an authorized Ditch Witch dealership for all warranty work.

Exclusions from Product Warranty

- All incidental or consequential damages.
- All defects, damages, or injuries caused by misuse, abuse, improper installation, alteration, neglect, or uses other than those for which products were intended.
- All defects, damages, or injuries caused by improper training, operation, or servicing of products in a manner inconsistent with manufacturer's recommendations.
- All engines and engine accessories (these are covered by original manufacturer's warranty).
- Tires, belts, and other parts which may be subject to another manufacturer's warranty (such warranty will be available to purchaser).
- ALL IMPLIED WARRANTIES NOT EXPRESSLY STATED HEREIN, INCLUDING ANY WARRANTY OF FITNESS FOR A PARTICULAR PURPOSE AND MERCHANTABILITY.

IF THE PRODUCTS ARE PURCHASED FOR COMMERCIAL PURPOSES, AS DEFINED BY THE UNIFORM COMMERCIAL CODE, THEN THERE ARE NO WARRANTIES WHICH EXTEND BEYOND THE FACE HEREOF AND THERE ARE NO IMPLIED WARRANTIES OF ANY KIND WHICH EXTEND TO A COMMERCIAL BUYER. ALL OTHER PROVISIONS OF THIS LIMITED WARRANTY APPLY INCLUDING THE DUTIES IMPOSED.

Ditch Witch products have been tested to deliver acceptable performance in most conditions. This does not imply they will deliver acceptable performance in all conditions. Therefore, to assure suitability, products should be operated under anticipated working conditions prior to purchase.

Defects will be determined by an inspection within thirty (30) days of the date of failure of the product or part by CMW or its authorized dealer. CMW will provide the location of its inspection facilities or its nearest authorized dealer upon inquiry. CMW reserves the right to supply remanufactured replacement parts under this warranty as it deems appropriate.

Extended warranties are available upon request from your local Ditch Witch dealer or CMW.

Some states do not allow exclusion or limitation of incidental or consequential damages, so above limitation of exclusion may not apply. Further, some states do not allow exclusion of or limitation of how long an implied warranty lasts, so the above limitation may not apply. This limited warranty gives product owner specific legal rights and the product owner may also have other rights which vary from state to state.

For information regarding this limited warranty, contact CMW's Product Support department, P.O. Box 66, Perry, OK 73077-0066, or contact your local Ditch Witch dealer.

CLICK HERE TO **DOWNLOAD** THE COMPLETE MANUAL

- Thank you very much for reading the preview of the manual.
- You can download the complete manual from: www.heydownloads.com by clicking the link below



- Please note: If there is no response to CLICKING the link, please download this PDF first and then click on it.

CLICK HERE TO **DOWNLOAD** THE COMPLETE MANUAL