

CLAAS

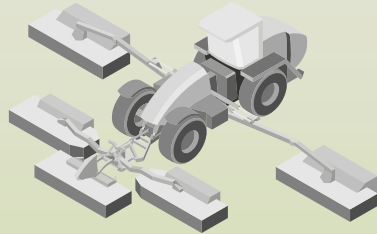

COUGAR 1400
COUGAR 1400 RC

Operator's Manual

SERVICE & PARTS

CLICK HERE TO **DOWNLOAD** THE COMPLETE MANUAL

- Thank you very much for reading the preview of the manual.
- You can download the complete manual from: www.heydownloads.com by clicking the link below



- Please note: If there is no response to CLICKING the link, please download this PDF first and then click on it.

CLICK HERE TO **DOWNLOAD** THE COMPLETE MANUAL

4 General instructions

4.1 Road travel

In other countries, different traffic regulations may apply. In the event of variations from the manufacturer's data, the regulations of the country concerned always take precedence.

Apart from his driving licence, the operator of the self-propelled mower unit must always carry a copy of the Vehicle Type Approval supplied by the manufacturer, a warning triangle, and at least 2 wheel chocks.

When travelling on public roads with the self-propelled mower unit, all specifications and constraints mentioned in the copy of the Vehicle Type Approval (§ 18 , para. 5 StVZO) or in the vehicle's registration documents must be observed.

For machines with excess width (width across tyres), instead of the copy of the Vehicle Type Approval, the driver must carry an operating permit for the individual vehicle and an exemption certificate in accordance with § 70, para. 1, No. 1 and 2 of the StVZO. In addition, all the specifications and constraints mentioned in the Vehicle Type Approval for individual vehicles or in the exemption certificate must be observed. Requirements for the allocation of an exemption certificate vary from one federal state to another. Suitable warning signs must be attached in accordance with the relevant national regulations for marking excessively wide road vehicles, (e.g. warning signs at front and rear, two yellow – warning beacons– , etc.).

If parts of the self-propelled mower units whose nature or operation can be a hazard to other road users are changed subsequently, the Vehicle Type Approval becomes invalid, and a new Vehicle Type Approval must be applied for. For this, the machine must be checked and approved by the local Test Centre for Vehicle Safety (TÜV) to permit allocation of the certificate (§ 19 para. 2 StVZO).

If you have any doubts whether your Vehicle Type Approval is invalid, please contact us, the manufacturers, directly.

Number plates

As a self-propelled machine with a maximum speed of more than 20 km/h, the self-propelled mower unit is subject to the relevant number plate regulations.

Warning beacon

When driving on public roads and paths, warning beacons may only be fitted in the event of excess width

Working lights

The working lights must always be switched off when driving on the road!

All self-propelled mower units fulfil the safety regulations in accordance with the EU Machine Directive, and are given a CE mark and a Declaration of Conformity.

6. Persons must not be allowed to enter the area between the vehicle and the mower unit unless the vehicle has been secured to prevent it rolling away by applying the parking brake and / or inserting wheel chocks!
 7. Safe operation of the mower unit is only ensured if the cutter blades are fitted according to the regulations.
 8. Check the mower unit for damaged, missing or worn cutter blades before each use and replace the cutter blades if required!
 9. To prevent dangerous unbalance, missing or damaged cutter blades may only be replaced as a complete set, in accordance with manufacturer specifications!
 10. When changing any cutter blades, check the fixings in accordance with the manufacturer's specifications and replace if required!
 11. In particular, check how far the inner radius of the mower blade mounting stud has been worn by the mower blade. The mower blade bracket must be replaced by a new bracket with an unworn mower blade mounting stud at the latest when the groove worn reaches a depth of 3 millimetres, i. e. when the inner radius is reduced by 3 millimetres.
 12. It is also important to check the riveting of the mower blade mounting stud in the mower blade bracket and the wear on the outer edge of the mower blade bracket. Where necessary, all mower blade brackets on the cutting discs must be replaced with new mower blade brackets.
 13. The safety curtains must be inspected regularly, and worn or damaged curtains are to be replaced!
 14. The safety devices on the mower unit, e. g. canvas and hoods, provide protection against stones and other objects hurled upwards by the blades and also against access to danger areas. Therefore, they must always be placed in the protective position before starting work!
 15. The machine and the mower units should only be operated if all the protection devices are fitted and in the protection position!
 16. Standing in the working and danger area of the mower unit is prohibited! Special care is to be taken when working near roads and buildings!
 17. Before commissioning and during working, the skid plates must be resting on the ground!
 18. Also during correct use of the mower, it is possible for stones and similar objects to be flung away by the cutters. Therefore, nobody may ever stand in the danger area.
 19. During operation, sufficient safety distance to the cutters must be maintained!
 20. Do not stand in the machine's turning and / or slewing range!
 21. There are crushing and shearing points on parts powered by external sources (e. g. hydraulically)!
 22. When lowering / raising the mower units from the transport to the working position and vice-versa, there is a risk of crushing / shearing points being exposed. For this reason, do not go between the vehicle and the mower units. The lowering / raising movement must be carried out with the mower unit in horizontal position.
 23. Even after the PTO has been disengaged, the mowing unit can keep on running for a while. Approach the mower only when all movement has stopped.
 24. After collision with an obstacle, turn the mower unit off immediately and check for damage!
- #### **PTO operation**
1. The universal drive shaft may only be installed or removed with the engine turned off!
 2. When working with PTO drive, no persons are allowed near the rotating PTO shaft or the universal drive shaft!
 3. Only universal drive shafts prescribed by the manufacturer can be used!
 4. Always ensure that the protective tubes and guard cones for the universal drive shaft and PTO stub shaft are installed and in good condition! Make sure that universal drive shafts are properly covered by the guards, both in the transport and in the working position!
 5. Always make sure that the universal drive shaft is correctly installed and securely fastened!
 6. Use safety chains to prevent the drive shaft guards from rotating with the drive shaft!
 7. Before engaging the PTO, ensure that the selected speed and direction of rotation of the machine's PTO match the mower unit's permissible speed and direction of rotation!
 8. Before engaging the PTO, ensure that everybody stands clear of the machine at a safe distance!

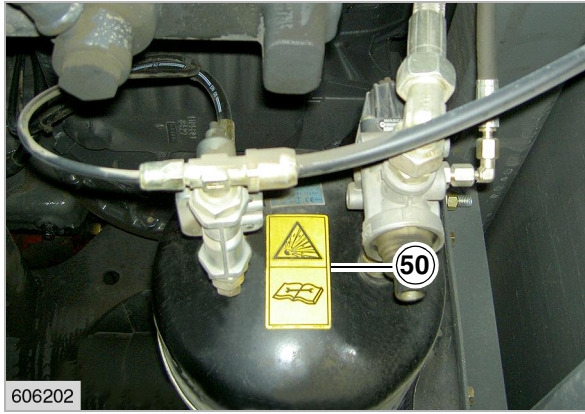

21

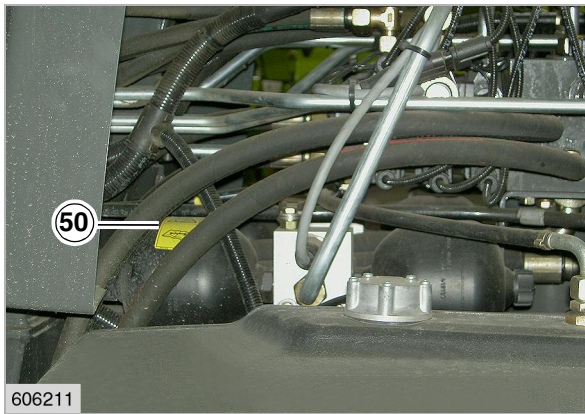

22

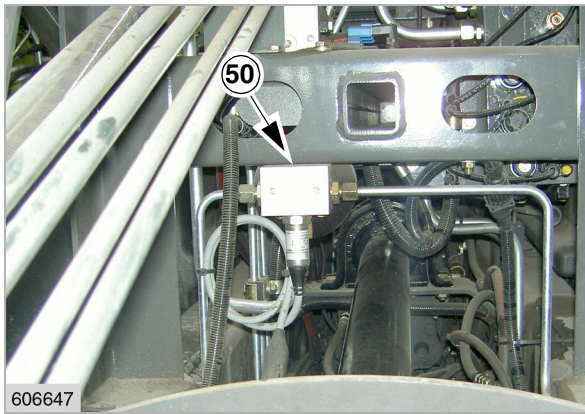

23

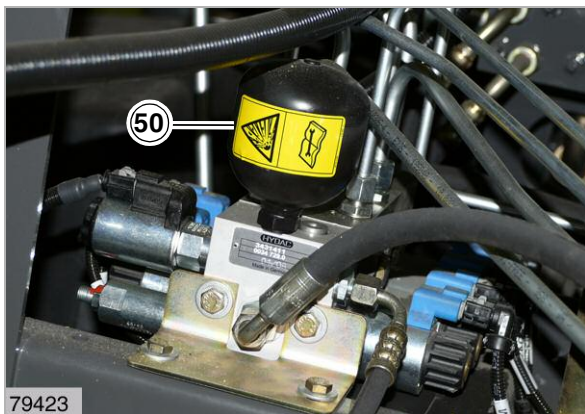

24

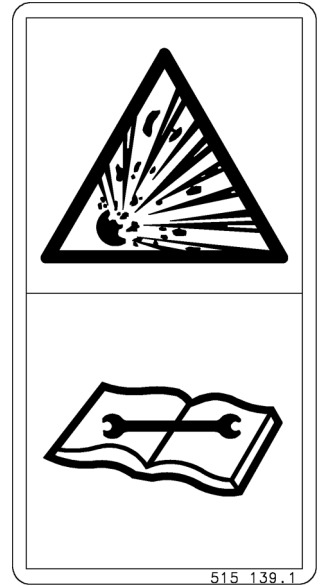

25

00 0515 139 1 (50)

Hydraulic accumulator contains pressurized gas and / or oil. For removal and repair, strictly follow the instructions in the technical manual.

(Fig. 21–25)

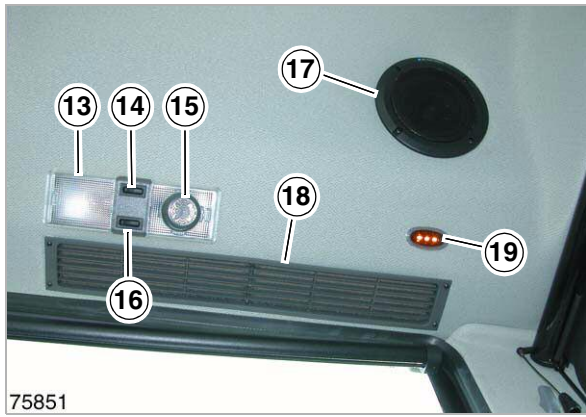

- 13 Cab lighting
- 14 Switching on / off cab lighting (S27)
- 15 Reading lamp
- 16 Switching off / on reading lamp
- 17 Speaker (radio fitting preparation)
- 18 Circulated air grille, air conditioning unit
- 19 LED lighting - switch console

(Fig. 2)

2

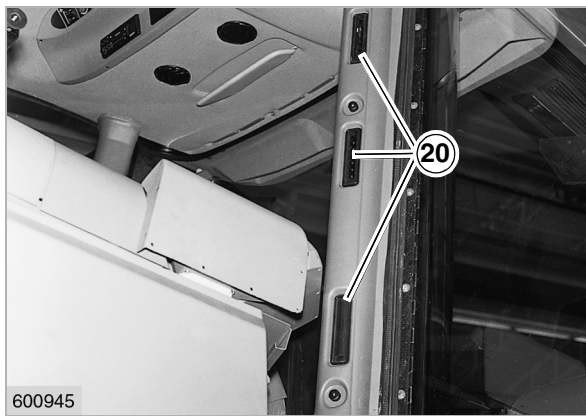

- 20 Air louvres

(Fig. 3)

3

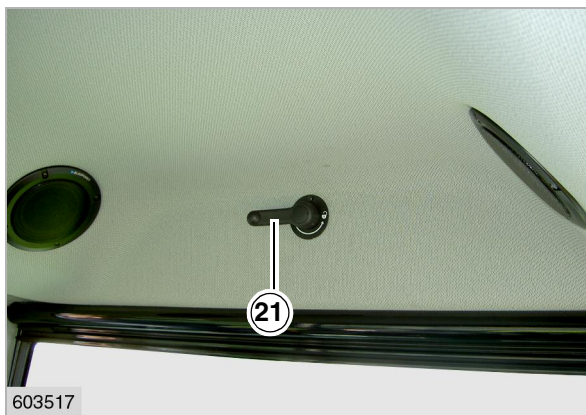

- 21 Lever for opening the cabin roof

(Fig. 4)

4

7.3.4 Starting mirror (optional equipment)

4 Starting mirror

Setting the starting mirror see *Adjusting "Working" mirrors*, page 50.

(Fig. 13)

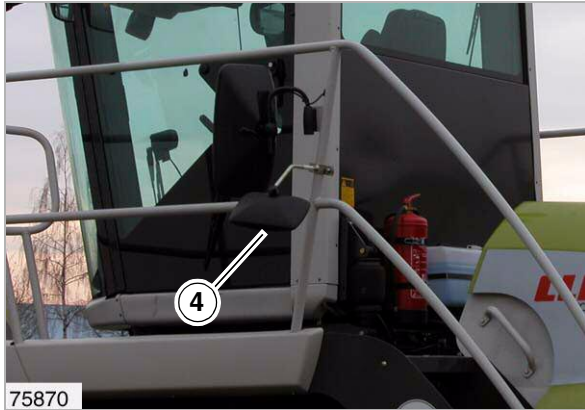

75870

13

Relays (K)

Item	Relay
K1	15a
K2	15b
K3	15c
K4	Power VCU / MCM
K8	Power EHL
K9	Start interlock
K10	Air conditioner compressor
K11	Reversing signal
K12	Side lights, turn indicator, instrument lighting,
K13	Alternator
K14	Brake lights
K15	Changeover reversing light
K19	Wheel rotation sensor 1 external
K20	Wheel rotation sensor 2 external
K23	Main beam
K24	Dipped beam
K25	Working lights cabin outer
K26	Working lights rear
K27	Working lights roof spare
K28	Working lights cabin outer
K29	Working lights Sidefinder left
K30	Working lights Sidefinder right
K39	Flasher relay
K41	Sensor Module
K43	Flashers

(Fig. 28, 29)

Main fuse

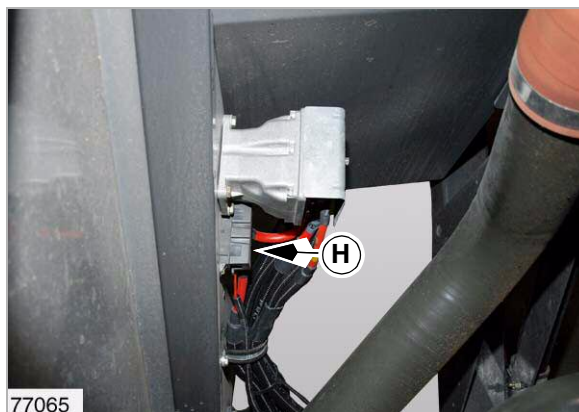

30

The main fuse (H) is located on the rear side of the battery compartment.



DANGER!

A defective main fuse indicates a serious defect in the electrical system – danger of fire!

- Have the electrical system checked by a specialist workshop.
- Remedy the fault in the electrical system
- and then replace the main fuse.

(Fig. 30)

7.14 Tyres

7.14.1 Mudguards on the mower unit axle

The mudguards on the mower unit axle are adjusted for the tyres supplied with the unit.

If tyres of a different size are fitted, the mudguards need to be altered accordingly.

Changing the mudguards:

- Remove the hex bolts (S) using a spanner (width across flats: 24 mm).
- Fit the mudguards in such a way that the minimum distance (A) of 60 mm between the mudguard and the tyre is maintained.

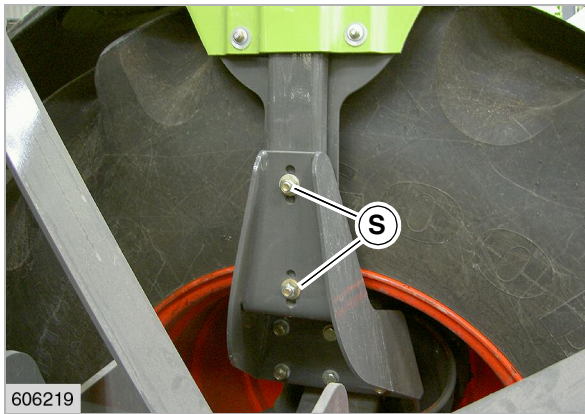

47

(Fig. 47, 48)

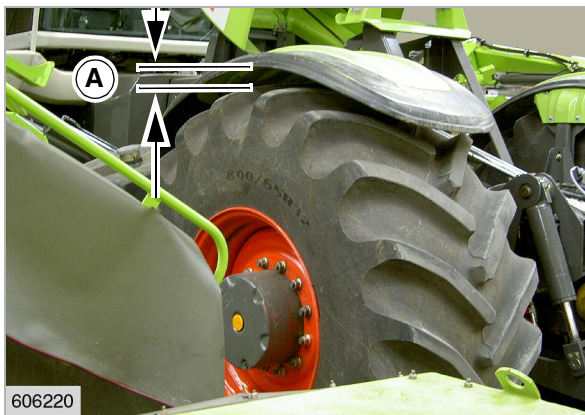

48

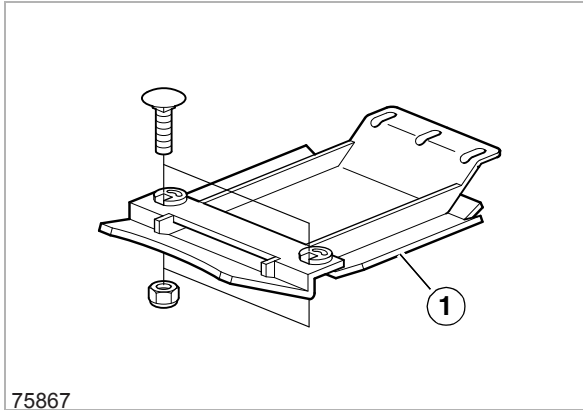

17

8.7.3 High cutting skids (B03 0020)

30 mm high cutting skids can be fitted for high cutting or for aggressive ground conditions.

The minimum cutting height thus increases by 30 mm.

- Mount the high cutting skids (1) on each of the outer sides of the mower units in place of the wear skids.

Ordering No:

High cutting skids (2 pieces) 5x 00 0482 275 0

(Fig. 17)



74571

18

Parking brake**DANGER!**

Always apply the parking brake before leaving the cab.

**CAUTION!**

Release the parking brake before each journey

Actuate the switch (S30) in order to actuate or release the parking brake.

(Fig. 18)

9.1.13 Parking the vehicle**DANGER!**

Before leaving the machine, always

- Switch off master switch “Mower unit drive”.
- Fold in the mower units into the transport position or lower them completely,
- Move the driving control lever to 0 position,
- Apply the parking brake,
- Turn the engine off,
- Remove the ignition key.
- Fit wheel chocks if required.

**CAUTION!**

Turbocharged engines should not be stopped from high speeds Allow the engine to run at idle speed for a short period before stopping.

Non-observance can cause damage to the turbocharger

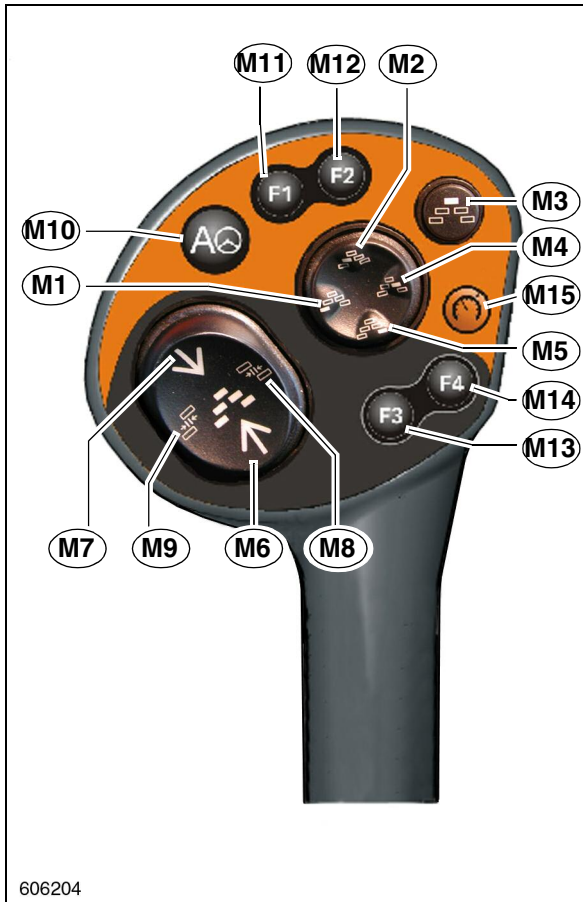

606204

3

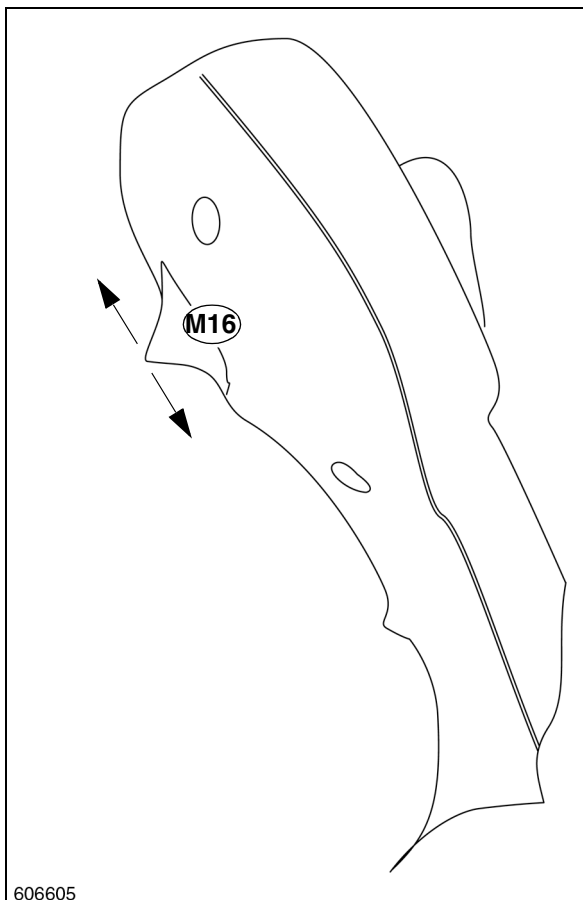

606605

4

10.1.2 Multifunction handle

NOTE: Adding “+ M16” reverses the respective function, with the exception of keys M6, M7 and M10. Example: Hold down M16 and press M2 = lower front left mower unit. Note the comments in *Reversal switch M16*, page 102.

- M1 Raise centre left mower unit
+ M16 lower
- M2 Raise front left mower unit
+ M16 lower
- M3 Raise front centre mower unit
+ M16 lower
- M4 Raise front right mower unit
+ M16 lower
- M5 Raise centre right mower unit
+ M16 lower
- M6 Headland up (raises all mower units)
1x press briefly = raise to headland position in accordance with the set mode **delayed**.
2x press briefly = raise to headland position **immediately** (all mower units simultaneously)
- M7 Headland down (lowers all mower units)
1x press briefly = lower mower units to the working position in accordance with the set mode **delayed**.
2x press briefly = lower all mower units **immediately** to the working position (all mower units simultaneously).
Mower unit floating 1st setting enabled
M16 Mower unit floating 2nd setting enabled
- M8 Overlap centre right mower unit
press briefly = activate standard overlap
+ M16 = activate curve overlap
press = reduce overlap
press + M16 = increase overlap
- M9 Centre left mower unit overlap
press briefly = activate standard overlap
press briefly + M16 = activate curve overlap
press = reduce overlap
press + M16 = increase overlap
- M10 Autopilot (not available at present)
- M11 Upper link
press = shorten / retract
press + M16 downwards = upper link lengthen / extend
press briefly + M16 upwards = upper link position Mowing 2 start
press briefly + M16 downwards = upper link position transport start
- M12 Lower link
press = lift
press + M16 downwards = lower
press briefly + M16 upwards = lower link position Mowing 2 start
- M13 Mower unit centre left
press = rotate outwards
press + M16 downwards = rotate inwards

- Upper link automatic system **not** active:
Upper link brought to working position.

Centre left and right mower units:

- Raise mower unit from the transport retainer by extending the 1st stage of the 2-stage telescopic outrigger about 20 cm.
- 2-stage telescopic outrigger swivelled out to folded position.
- Mower unit rotated to working position.
- Guard frames / curtains unfolded.
- Swing lock released.
- 1st stage of telescopic outrigger extended to programmed overlap.
- 2nd stage of telescopic outrigger completely extended.
- Telescopic outrigger brought to headland position.

On completion of the extension process:

- The mower units are now in the headland position.
- All guard frames folded to safety position.

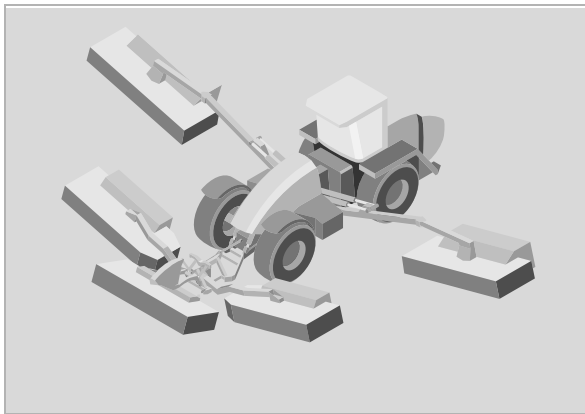

20



73479

41



77081

42

10.2.5 Headland position

The semi-automatic headland system is activated by briefly pressing the button M6 (lifting) or M7 (lowering). In this way, the mower units are raised to the headland position or lowered to the working position in accordance with the pre-set mode and the programmed target values. The mower units are raised and lowered in the following sequence:

- Front centre mower unit: always **immediately** (without delay)
- Front left and right mower units: delayed in accordance with the target value “Front up / down L/R”
- Centre left and right mower units: delayed in accordance with the target value “Centre up / down L/R”

The mower unit floating can only be adjusted in the CEBIS – see “Headland” menu, page 192.

The automatic headland can only be enabled with the mower unit drives engaged.



NOTE!

If the machine comes to a stop while the speed-dependent semi-automatic headland is active, the semi-automatic headland will be stopped after the programmed time-out – see *Speed-dependent delay*, page 196.

The mower units are only raised until the system stops, and they remain in the position that they have reached. This prevents the mower units from raising or lowering unexpectedly when starting up again.

All the mower units can be raised immediately to the headland position automatically by briefly pressing **2x** the button (M6)

Alternative: Hold button (M6) down until the desired position (maximum headland position) is reached (manually).

(Fig. 41, 42)

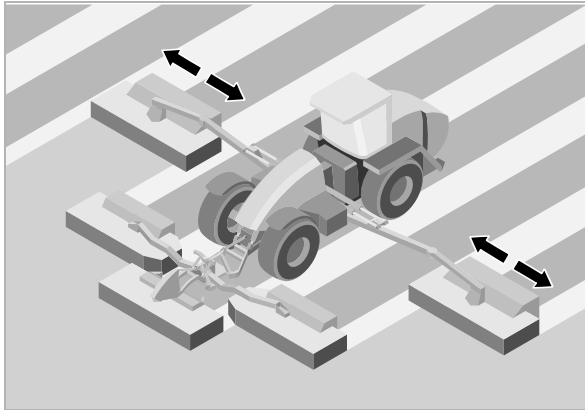

57

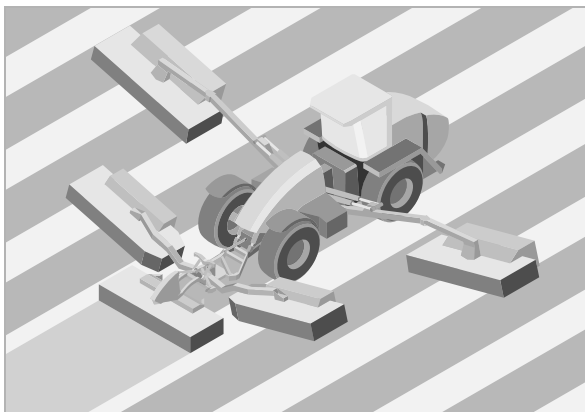

58

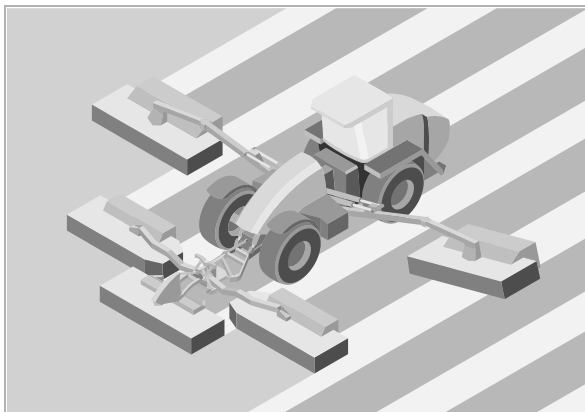

59

10.3.2 Working with single mower units

The following options are available for mowing small areas:

- Continuous adjustment of the working width by increasing or reducing the overlap between centre left / right mower unit and front left / right mower unit – see *Working width of mower unit*, page 126. The overlap can also be adjusted with the mower unit raised.
- Raising mower units that are not required to the headland position while mowing. Briefly press the corresponding keys on the multifunction handle for this. The same applies for lowering the mower units to the working position – see *Example “Semi-automatic function”*, page 105.

Possible procedures at the headland

The mower units are automatically lowered to working position or raised to headland position by briefly pressing the keys on the multifunction handle. Floating is active after lowering the relevant mower unit.

Working with 3 to 4 mower units:

- Lower the mower unit to the ground using the button “Headland down” (press briefly).
- Then raise the mower units that are not required to the headland position with the corresponding key (press briefly).

Working with 1 to 2 mower units:

- Lower the mower units singly with the corresponding key on the multifunction handle.

To lower a mower unit at the headland without automatic headland, simply raise the corresponding mower unit **via** the “Headland position” – see *Example “Manual operation”*, page 108.

If a mower unit has to be raised higher due to lack of space, first turn off the corresponding mower unit drive – see *Mower unit drive*, page 116.

To enable the mower unit to be lowered again to working position with the automatic headland:

- Lower mower unit at least to headland height manually – see *Example “Manual operation”*, page 108.

Other procedures may come into question depending on the experience and skill of the driver.

(Fig. 57, 58, 59)

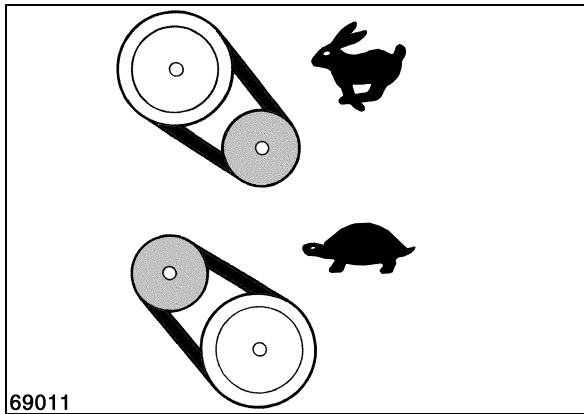

90

Changing conditioner speed

The drive pulleys can be changed to set the speed of the conditioner. Proceed as follows:

- Release drive belt tension.
- Remove belt guard.
- Exchange pulleys.
- Replace belt guard.
- Tension drive belt – see *Tensioning the conditioner drive belts, COUGAR 1400*, page 326.

The arrangement of the pulleys dependent on the conditioner speed is shown in fig. 90.

Conditioner speed – see *Mower units*, page 39.

(Fig. 90)

10.3.8 Mowing without conditioning effect (COUGAR 1400 RC only)

The machine can be used without the effect of the roller conditioner. To do this, swing the top roller upwards.

- Remove tension spring (3) on both sides.
- Release nut (2).
- Unscrew bolt (1).
- Remove tension spring (3).

(Fig. 91, 92)

Front centre mower unit, centre mower unit left / right

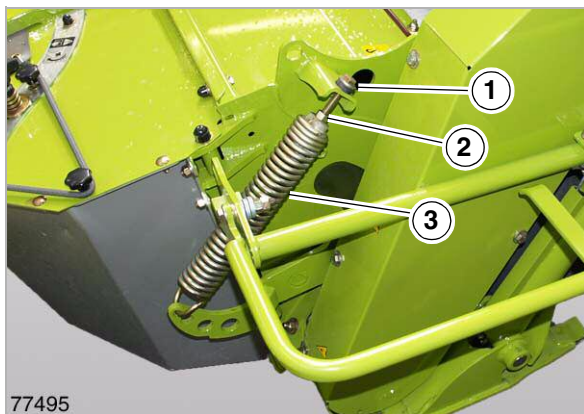

91

Front mower unit left / right

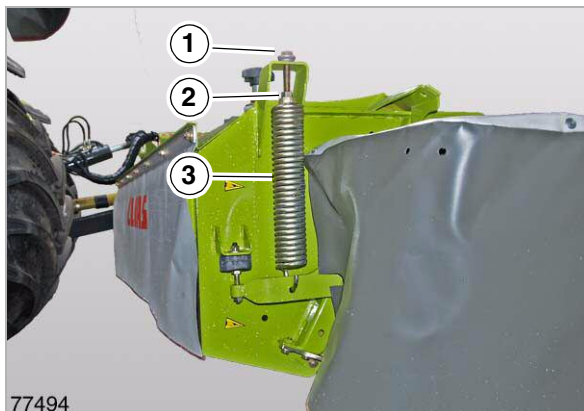

92

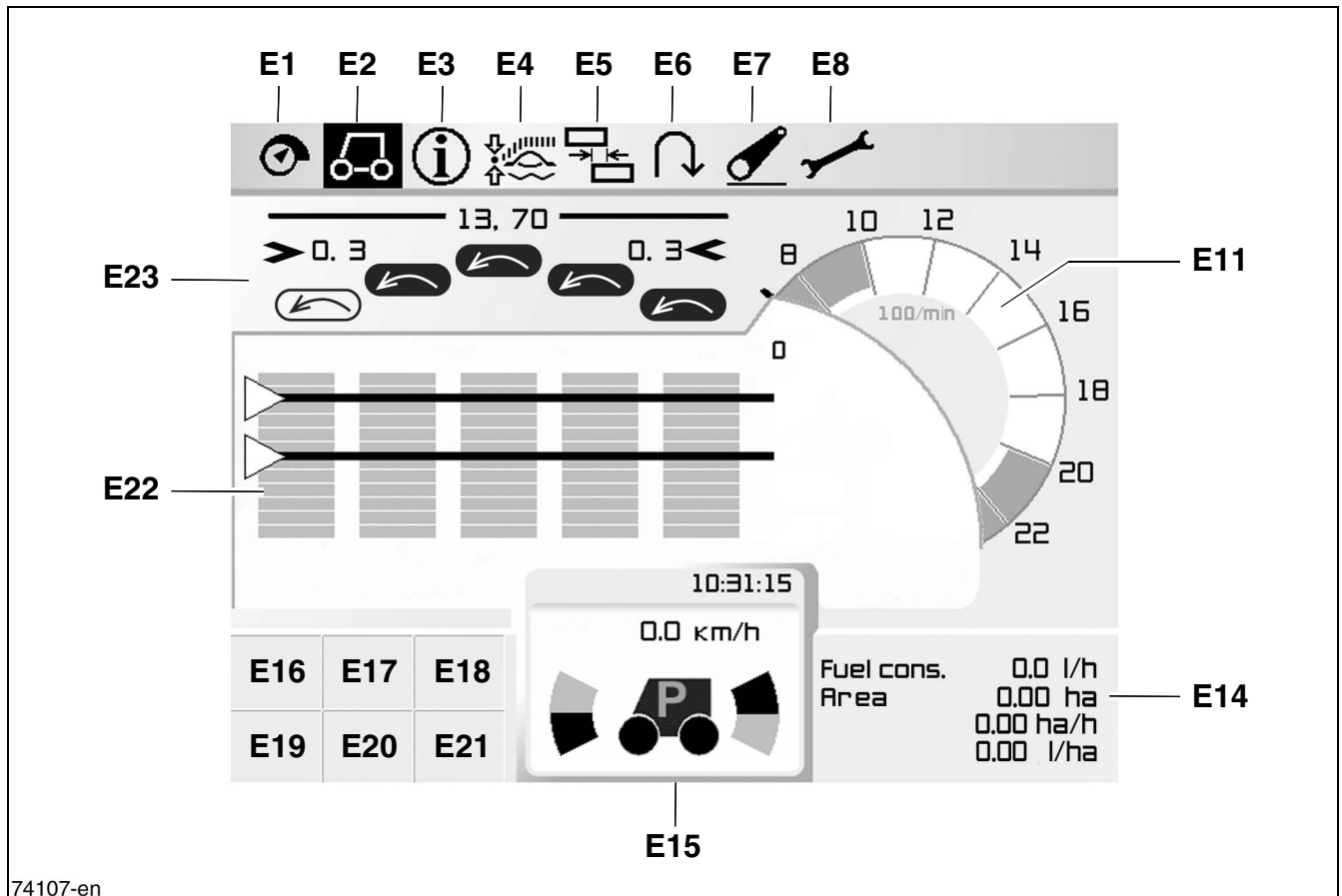

74107-en

4

11.2.5 Screen areas E

(Work view)

- E 1 = Settings menu
 - E 2 = Vehicle menu
 - E 3 = Drive information menu
 - E 4 = Ground pressure menu
 - E 5 = Overlap menu
 - E 6 = Headland menu
 - E 7 = Lifting unit menu
 - E 8 = Service menu
 - E 9 = covered
 - E 10 = covered
 - E 11 = Engine speed
 - E 12 = covered
 - E 14 = Fuel consumption, area, area output, fuel consumption per unit area
 - E 15 = Central window: Vehicle status display combined with parking brake status, turn indicator, steering angle display, ground speed, time of day
 - E 16 = Annunciator
 - E 17 = Annunciator
 - E 18 = Annunciator
 - E 19 = Annunciator
 - E 20 = Annunciator
 - E 21 = Annunciator
- Further information concerning annunciators – see *Faults and remedies*, page 224.

- E 22 = Ground pressure float
- E 23 = Total working width, mower unit position (transport / headland / working position), mower unit overlap



NOTE!

By pressing the ESC key you can also toggle between “road view” and “working view”.

(Fig. 4)

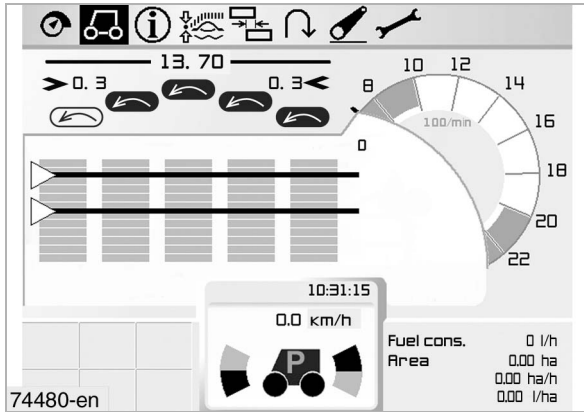

25

11.6.1 Calling the “Vehicle” menu

 Select the “Vehicle” menu using the (<) or (>) key.

 The “Vehicle” menu opens.

 Exit the menu without making changes.

(Fig. 25, 26)

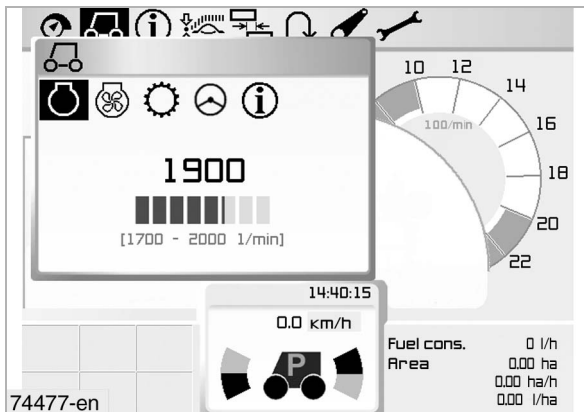

26

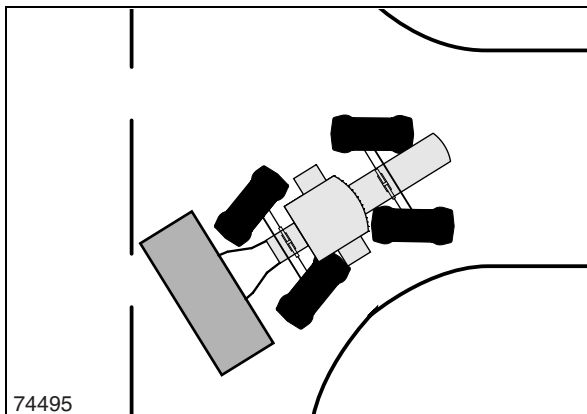

74495

43

4-wheel steering without regaining



DANGER!

Especially in the case of large steering angles, the mower unit front centre can project over the outer edge of the curve.

The mower unit axle is steered in the opposite direction to the main axle. This causes the steering process of the main axle and the mower unit axle to act simultaneously, thus providing more sensitive handling, compared to 4-wheel steering with regaining. The vehicle swings out to the outside of the curve and the mower units can extend beyond the outer edge of the curve.

(Fig. 43)

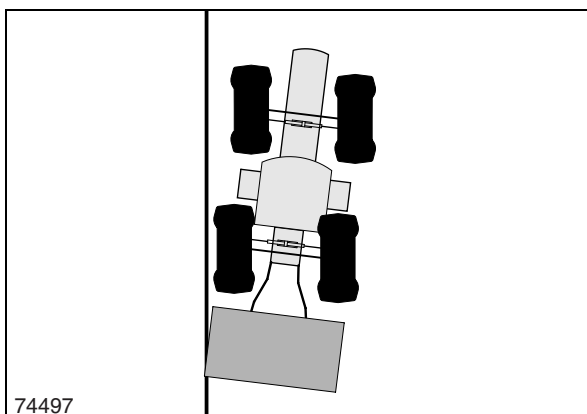

74497

44

Crab steer mode



NOTE!

With the crab steer mode program, the axle angle of the mower unit axle can be set using the foot switch (F) in the driver's cab. The main axle is set via the steering wheel.

When steering the main axle in the set direction, the tyre tracks of the engine and mower unit axles are next to each other, whilst when steering the main axle in the opposite direction, 4-wheel steering is effective.

The crab steer mode is recommended for driving on inclines, where steering corrections are required on both axles to guarantee the correct tracking, or where the sward is only to be traversed once.

The crab steering angle is variable up to a max. value of approx. 15°. This allows optimum adaptation to the width of the tyres used. See *Setting maximum crab steering angle*, page 176.

In the case of larger steering wheel movements, e.g. when turning at the end of a field, the steering behaviour corresponds to 4-wheel steering in both directions in order to increase the manoeuvrability.

(Fig. 44, 45)

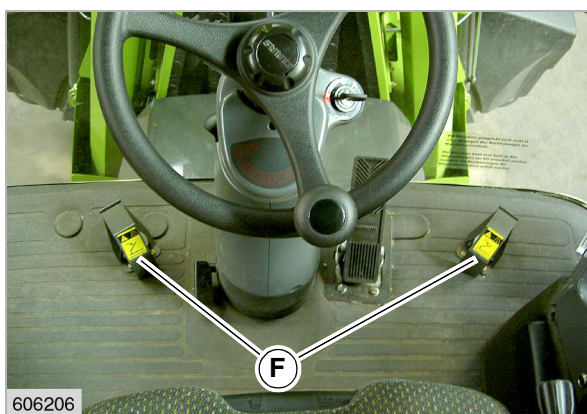

606206

45

11.8 “Ground pressure” menu

In order to provide better sliding over the grass, the weight can be reduced in the ground pressure menu. The higher the ground pressure float is set, the larger is the proportion of the weight carried by the vehicle.

Under very uneven ground conditions, the amount of float on each mower unit can be set individually.

11.8.1 Calling the “Ground pressure” menu

 Select the “Ground Pressure” menu using the (<) or (>) key.

 The “Ground pressure” menu opens.

 Exit the menu without making changes.

(Fig. 70, 71)

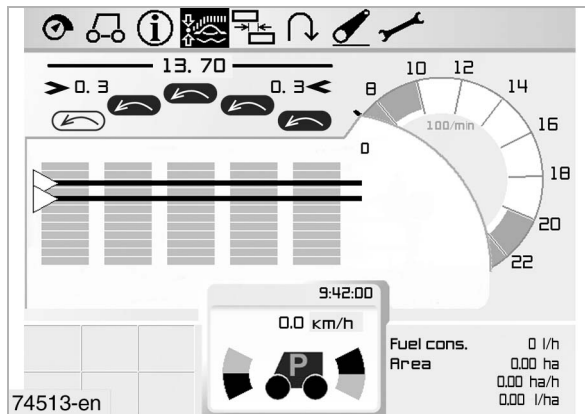

70

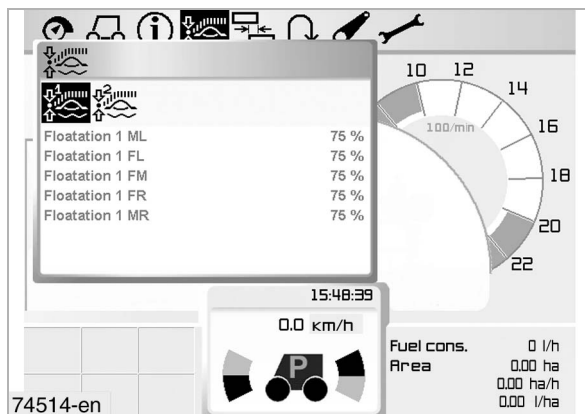

71

11.9.6 Overlap display in the working view

While working, the current overlap is displayed in the working view on the CEBIS monitor:

The symbols used have the following meaning:

Display	Meaning
V	Curve overlap active e.g.: centre right mower unit (Fig. 90)
<>	Overlap changed manually. The adjustment symbol shows the direction of the adjustment. e.g.: centre left mower unit retracted to the centre (overlap greater than 1st set value) (Fig. 91)

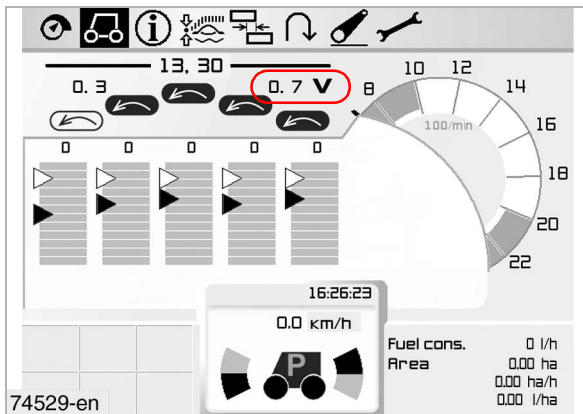

90

In the adjacent example the overlap for the centre left mower unit is 0.30 m and is not indicated by an adjustment symbol. This indicates that the overlap is set to set value 1 for straight ahead travel (standard overlap).

For the centre right mower unit the overlap is 0.70 m and is indicated by the adjustment symbol (V). This indicates that, at the present time, the overlap is set to set value 2 for curve travel.

The total physical working width after subtraction of the overlaps can be read above the segment width symbol. In the adjacent example the value is 13.30 m. (Fig. 90)

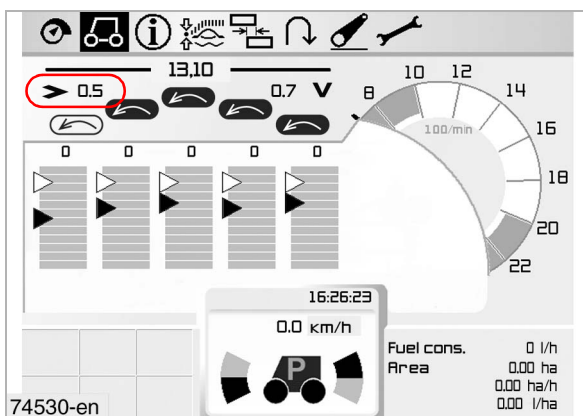

91

Manual adjustment of the overlap is indicated by one of the adjustment symbols (<) or (>):

In the adjacent example, the overlap for the centre left mower unit is 0.50 m and is indicated by the adjustment symbol (>). The adjustment symbol shows the direction of the adjustment: The mower unit has been retracted towards the centre and the current overlap is increased.

(Fig. 91)

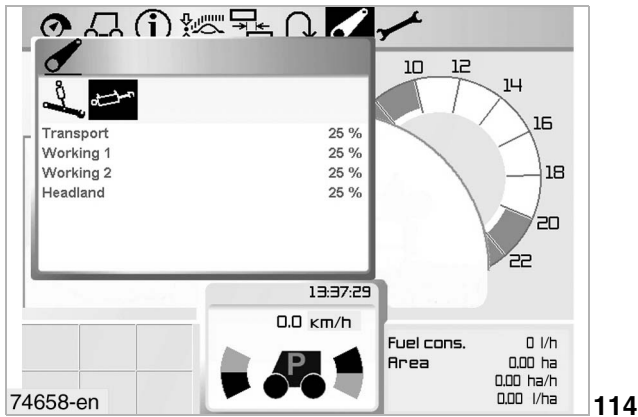

Adjusting the upper link



Call the “Lifting unit” menu.



Select the “Upper link” sub-menu using the (<) or (>) key.

The current settings are displayed.



The “Upper link” sub-menu opens.



Select the set value to be adjusted using the (<) or (>) key:



Transport



Mowing 1 (Working position 1)



Mowing 2 (Working position 2)



Headland



The selected set value is active.

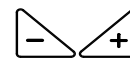

Press the (+) or (–) button until the required value (S) is displayed on the monitor

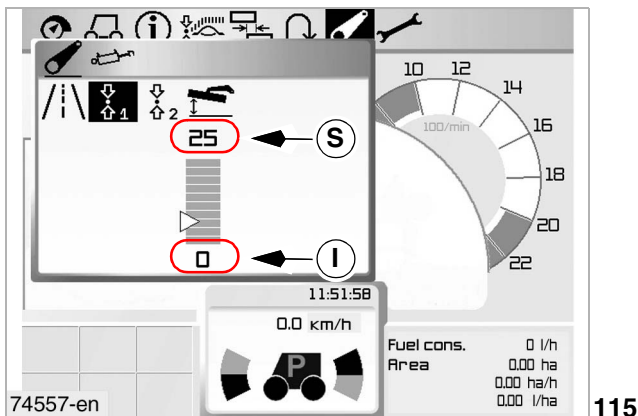

The displayed actual-value (I) indicates the current lifting height in percent.

Adjustment range:

- Transport: 15% to 35%
- Mowing 1: 5% to 75%
- Mowing 2: 5% to 75%
- Headland: 0% to 50%

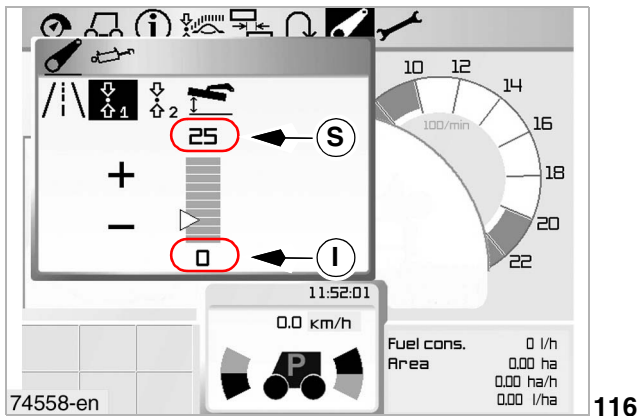

Save the displayed value and exit the menu.



Exit the menu without making changes.



NOTE!

With the automatic system activated (headland, mowing or transport) changing the set value in the corresponding automatic system effects an immediate adjustment of the upper link.

(Fig. 114, 115, 116)

CLICK HERE TO **DOWNLOAD** THE COMPLETE MANUAL

- Thank you very much for reading the preview of the manual.
- You can download the complete manual from: www.heydownloads.com by clicking the link below



- Please note: If there is no response to CLICKING the link, please download this PDF first and then click on it.

CLICK HERE TO **DOWNLOAD** THE COMPLETE MANUAL

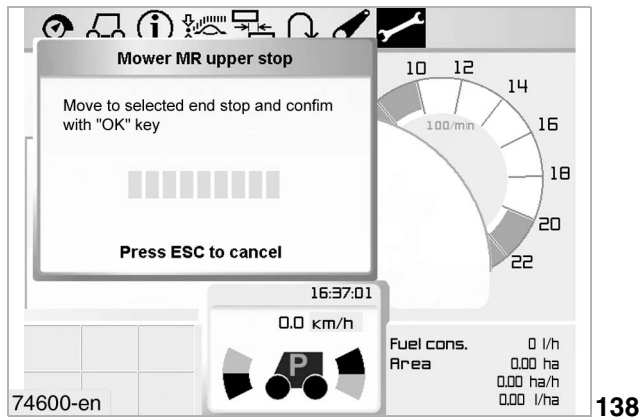

Start the selected learning procedure.



Interrupt the selected learning procedure.

- Allow engine to run at idle speed by:
 - Rotary switch (S25) set to position .
 - Switch on the hydraulic main switch (S29).
 - Switch off master switch (S4) “Mower unit drive”.
 - Start the function with the rocker switch (S17).
 - Follow the instructions on the CEBIS monitor.
- Successful learning is confirmed by a corresponding message.
- If required, observe the warning signal tone.



NOTE!

If necessary, the upper link must be fully retracted before learning the end limit “lower link”. Otherwise, there is the possibility that the mower units are already on the ground / resting on the ground before the lower links have reached the bottommost position.

In order to learn the limit stop “upper link extended”, it may be necessary to extend the lower links upwards to the full extent. Otherwise, there is the possibility that the mower units are already on the ground / resting on the ground before the upper link is fully extended.

Always watch out for possible collisions!



Select the next function using the (<) or (>) buttons.



Press the ESC button to:

- exit the “Limit stops” menu.
- revert to the “Maintenance” menu.

(Fig. 136–139)

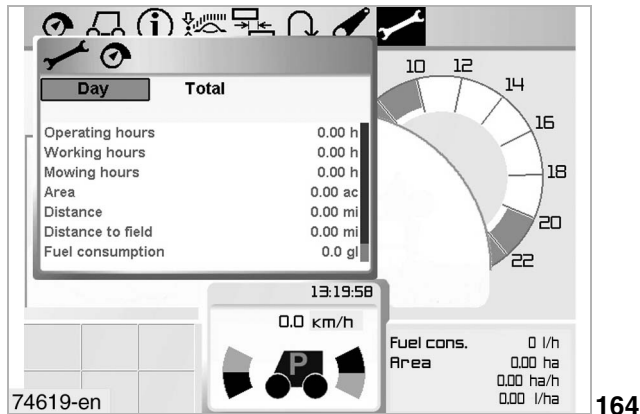

11.12.19 “Counter” menu

The counter menu is sub-divided into a day counter and a total counter. The following data can be called up:

- Operating hours
- Working time
- Mowing hours
- Area
- Distance travelled
- Distance travelled to the field
- Fuel consumption
- Working consumption

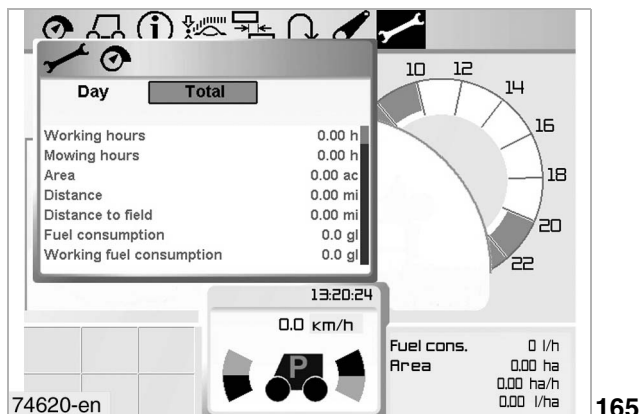

Day counter

In the day counter, all the values since the last reset process are summed. The reset (clear) procedure of the day counter is recorded – see *Resetting the “Day” counter menu*, page 223.

Total counter

In the total counter all values since the commissioning of the machine are summed. The total counter cannot be reset.

Operating hours

is the time for which the engine has been running at a speed > 500 rpm.

Working time

is the operating hours where at least one mower unit has been in operation.

Mowing hours

is the working time for which at least one mower unit has been lowered in the working position.

Area

is the area traversed with the current working width with activated ground pressure regulation and switched on mower drive.

Distance travelled

is the distance travelled in all directions.

Distance travelled to the field

is the distance travelled with the cabin in the “Road travel” position.











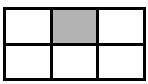

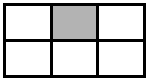

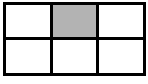

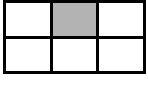

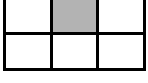

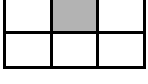

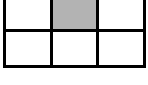
Fuel consumption

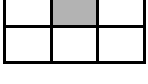
is the consumed volume of fuel.

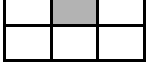
ID No.	Message field	Symbol	Meaning / Cause	Remedy
11E6			Unknown warning (0x11E6)	Help message for development. Report occurrence in field.
11E7			Unknown warning (0x11E7)	Help message for development. Report occurrence in field.
11E8			Unknown warning (0x11E8)	Help message for development. Report occurrence in field.
11E9			Unknown warning (0x11E9)	Help message for development. Report occurrence in field.
11EA			Unknown error (0x11EA)	Help message for development. Report occurrence in field.
11EB			Unknown error (0x11EB)	Help message for development. Report occurrence in field.
11EC			Unknown error (0x11EC)	Help message for development. Report occurrence in field.
11ED			Unknown error (0x11ED)	Help message for development. Report occurrence in field.
11EE			Unknown error (0x11EE)	Help message for development. Report occurrence in field.
1700			General operating system fault	Report the event
1800			Engine oil pressure too low	Check oil level. If required check oil pressure Pump fault, switch fault or CAN fault possible.
1801			Engine oil level too low	Check oil level. Possible sensor defect or CANbus fault
1802			Coolant too low	Check coolant level. Possible sensor defect or CANbus fault
1803			Engine temperature too high	Stop engine. Check radiator for dirt, clean if required. Check coolant level. Possible sensor defect or CANbus fault
1804			Charge air temperature too high	Stop engine. Check radiator for dirt, clean if required. Possible sensor defect or CANbus fault
1805			Air filter cartridge blocked	Clean air filter or replace cartridge. Sender may be defective. Check plug socket and cable.
1806			Fuel filter blocked	Clean fuel filter or replace. Maybe sensor faulty or CAN fault

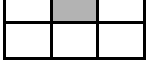
ID No.	Message field	Symbol	Meaning / Cause	Remedy
645C			Steering system fault Emergency steering active Reduce speed	Mower unit axle: Axle turn-in of the steering too slow. Relieve steering system, check hydraulic pressures and quantities, if necessary, call in Service department. CCN: B152 FMI: 10
645D			Steering system fault Emergency steering active Reduce speed	Mower unit axle: Axle turn-in of the steering too slow. Relieve steering system, check hydraulic pressures and quantities, if necessary, call in Service department. CCN: B152 FMI: 10
645E			Steering system fault Emergency steering active Reduce speed Wrong pin assignment or fatal logic error	Main axle: Check plug socket and cable, if necessary, call in Service department. CCN: B152 FMI: 7
645F			Steering system fault Emergency steering active Reduce speed	Main axle: Axle turn-in of the steering too slow. Relieve steering system, check hydraulic pressures and quantities, if necessary, call in Service department. CCN: B152 FMI: 10
6460			Steering system fault Emergency steering active Reduce speed	Main axle: Axle turn-in of the steering too slow. Relieve steering system, check hydraulic pressures and quantities, if necessary, call in Service department. CCN: B152 FMI: 10
6467			Steering system fault Emergency steering active Reduce speed	Steering system to be checked by Service. Calibrate the steering system with the vehicle at a standstill with CDS. CCN: A55 FMI: 13
6468			Steering system fault Emergency steering active Reduce speed	Mower unit axle: Steering system to be checked by Service. Recalibrate axle with CDS. CCN: A55 FMI: 13
6469			Steering system fault Emergency steering active Reduce speed	Steering system to be checked by Service. Recalibrate axle with CDS. CCN: A55 FMI: 13
6470			Steering system fault Emergency steering active Reduce speed CAN bus faulty or vehicle basic module sending incorrect signal.	Restart vehicle. Check CAN bus. If necessary, replace basic module. CCN: A69 FMI: 17
6471			Steering system fault Emergency steering active Reduce speed CAN bus faulty or vehicle basic module sending incorrect signal.	Restart vehicle. Check CAN bus. If necessary, replace basic module. CCN: A69 FMI: 17

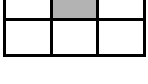
ID No.	Message field	Symbol	Meaning / Cause	Remedy
81D2			No pulses/100m set! No area count and no distance travelled display	
81D3			Pulses per 100m learning running	
81D4			Learning pulses interrupted	
81D5			Learned pulses implausible	
81D6			Switch engine off to learn the drive control lever	
81D7			Learning takes place from drive control lever neutral position	
81D8			Learning running: Move the drive control lever to the 4 prescribed stops one after the other. Observe the confirmation beeps	
81D9			Set cab and road travel switch to "Road" to learn the hydrostat	
81DA			In order to learn the hydrostat, set the engine speed switch to "Maximum Speed" (1100 rpm)	
81DB			Move the drive control lever to the front stop	
81DC			In order to learn the hydrostat gearbox, screw in the gearbox neutral screw	
81DD			Learning hydrostat running.	
81DE			Learning hydrostat not possible: Drive control lever not learned	
81DF			Learning hydrostat not possible: Ground speed limited (e.g. steering error)	
81E0			Unknown information (0x81E0)	Help message for development. Report occurrence in field.
81E1			Unknown information (0x81E1)	Help message for development. Report occurrence in field.
81E2			Unknown information (0x81E2)	Help message for development. Report occurrence in field.

ID No.	Message field	Symbol	Meaning / Cause	Remedy
826B			Fault - Mower unit control system Solenoid Lower front mower unit centre	Restart vehicle. Check plug socket and cable, replace solenoid magnet. CCN: Y218 FMI: 6
826C			Fault - Mower unit control system Solenoid Retract upper link	Restart vehicle. Check plug socket and cable, replace solenoid magnet. CCN: Y206-1 FMI: 6
826D			Fault - Mower unit control system Solenoid Extend upper link	Restart vehicle. Check plug socket and cable, replace solenoid magnet. CCN: Y206-2 FMI: 6
826E			Fault - Mower unit control system Solenoid Raise front force lifter	Restart vehicle. Check plug socket and cable, replace solenoid magnet. CCN: Y211 FMI: 6
826F			Fault - Mower unit control system Solenoid Lower front force lifter	Restart vehicle. Check plug socket and cable, replace solenoid magnet. CCN: Y212 FMI: 6
8270			Fault - Mower unit control system Solenoid Fold guard frame to transport position	Restart vehicle. Check plug socket and cable, replace solenoid magnet. CCN: Y201 FMI: 6
8271			Fault - Mower unit control system Solenoid Fold guard frame to working position	Restart vehicle. Check plug socket and cable, replace solenoid magnet. CCN: Y200 FMI: 6
8273			Fault - Mower unit control system Solenoid coupling drive (Mower unit centre left)	Restart vehicle. Check plug socket and cable, replace solenoid magnet. CCN: Y199-2 FMI: 6
8274			Fault - Mower unit control system Solenoid coupling drive Mower unit centre right	Restart vehicle. Check plug socket and cable, replace solenoid magnet. CCN: Y199-1 FMI: 6
8275			Fault - Mower unit control system Solenoid coil front PYO on	Restart vehicle. Check plug socket and cable, replace solenoid magnet. CCN: Y243 FMI: 6
8280			Overload - Mower unit centre left / right	Switch-off due to slip at the mower unit slip clutches. Lower load, check clutches if necessary. Possible error in speed management. Check plug socket and cable, if necessary, replace speed sensor. CAN bus problem possible. For emergency operation: Switch off monitoring in CEBIS. Restart vehicle. CCN: B163-4 FMI: 1

ID No.	Message field	Symbol	Meaning / Cause	Remedy
8311			Fault - Mower unit control system Centre right outrigger position sensor	Restart vehicle. CCN: B140-2 FMI: 3 B140-2 4
8312			Fault - Mower unit control system Front left outrigger position sensor	Restart vehicle. CCN: B140-3 FMI: 3 B140-3 4
8313			Fault - Mower unit control system Front right outrigger position sensor	Restart vehicle. CCN: B140-4 FMI: 3 B140-4 4
8315			Fault - Mower unit control system Sensor position telescopic arm left	Restart vehicle. CCN: B162-1 FMI: 3 B162-1 4
8316			Fault - Mower unit control system Sensor position telescopic arm right	Restart vehicle. CCN: B162-2 FMI: 3 B162-2 4
8317			Fault - Mower unit control system Sensor position upper link	Restart vehicle. CCN: B160 FMI: 3 B160 4
8318			Fault - Mower unit control system Sensor position lower link	Restart vehicle. CCN: B139 FMI: 3 B139 4
831C			Fault - Mower unit control system Centre left swing angle sensor	Restart vehicle. CCN: B161-1 FMI: 3 B161-1 4
831D			Fault - Mower unit control system Centre right swing angle sensor	Restart vehicle. CCN: B161-2 FMI: 3 B161-2 4
8320			Automatic error Centre left outrigger position sensor faulty	
8321			Automatic error Centre right outrigger position sensor faulty	
8322			Automatic error Front left outrigger position sensor faulty	
8323			Automatic error Front right outrigger position sensor faulty	
8325			Automatic error Sensor position telescopic arm left faulty	
8326			Automatic error Sensor position telescopic arm right faulty	
8327			Automatic error Telescopic arm left not retracted	

Maintenance Operations	Service intervals									
	before harvest	every day	after the first		Every			annually = every 500 hours	as required	after harvest
			40	100	50	125	250			
			operating hours		operating hours					
Compressed air system / brakes										
- Checking / tightening the retaining straps									●	
- Checking / cleaning the drain valve									●	
- Checking the pressure regulator									●	
- Checking the safety valve									●	
- Check the compressed air vessel										every 2 years ●
- Bleed the foot brake unit										every 2 years ●
- Tighten drive belts of mower unit centre left / right										●
- Tension drive belt, front PTO shaft										●
Bolts										
- Tighten all wheel nuts as specified										●
- Check all bolted connections, tighten if necessary										●
Electrical system, see <i>Maintenance – Engine</i>										
Lubrication points, see <i>Lubrication chart</i>										

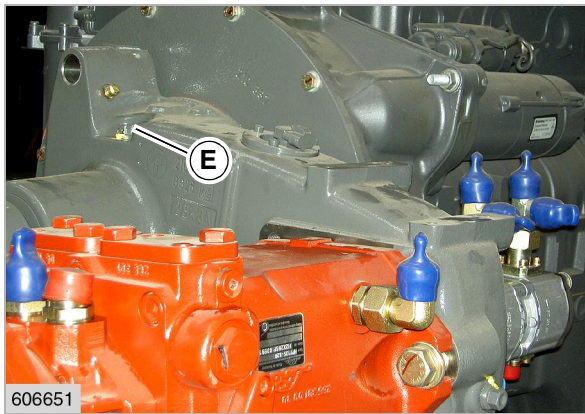

22

Topping up the oil in transfer gearbox

- Remove the oil filler screw (E).
- Pour in gearbox oil until the oil reaches the bottom edge of the oil checking hole (K).
- Replace the oil filling and checking plug.

(Fig. 20, 22)

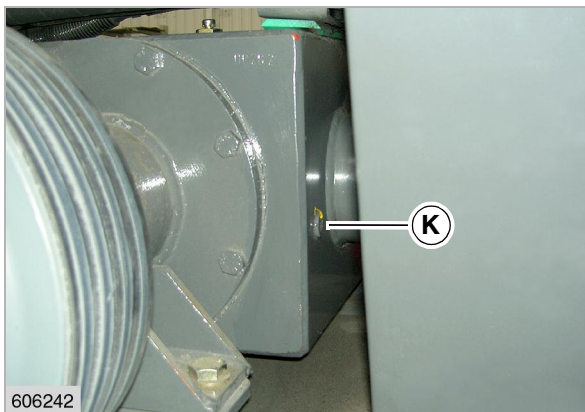

23

12.5.3 Transfer gearbox of mower units

Check oil level in transfer gearbox

- Check oil level in sight glass (K).

The oil must come half way up the glass.

Top up transmission oil if required *Topping up the oil in mower unit transfer gearbox*, page 292.

(Fig. 23)

Design A

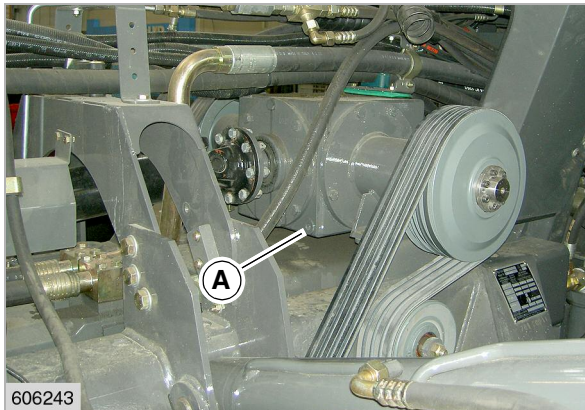

24

Changing the oil in mower unit transfer gearbox

i NOTE!

There are three different designs for the oil drain plug on the transfer gearbox.

Instructions for design A

- Place a sufficiently large container beneath the oil drain plug (A).
- Unscrew the oil drain plug and drain the oil completely.
- Refit the oil drain plug and tighten it to be oil-tight.

(Fig. 24)

12.9.2 Cleaning the units located in the cabin roof

- Remove the cover (D) from the cabin roof.
- Blow out the units with compressed air (max. 5 bar).

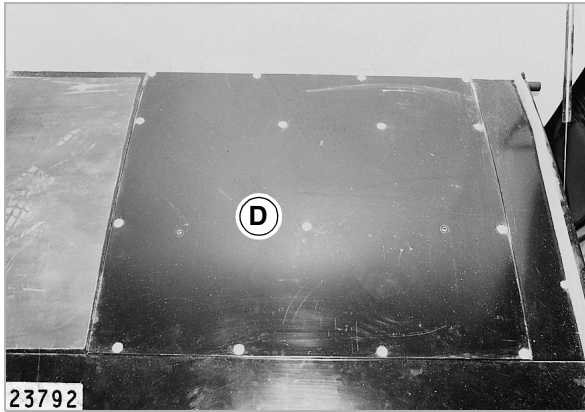

40



CAUTION!

Take care not to damage the fins.

Never use a steam-jet cleaner.

Damaged seals under cover (D) must be replaced.

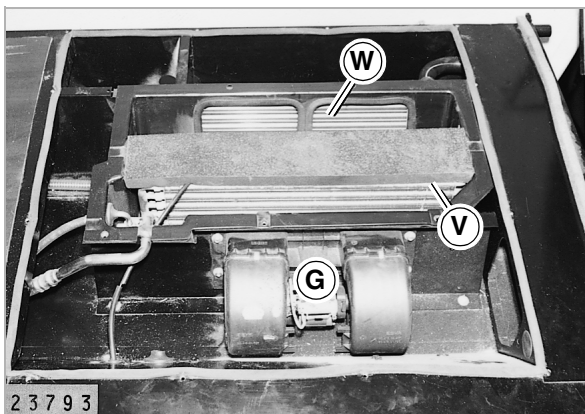

41

W = Hot water radiator

V = Evaporator

G = Fan

Clean the hot water radiator (W) and the evaporator (V) at least once a year and more frequently if heavy dust loads occur.

(Fig. 40, 41)

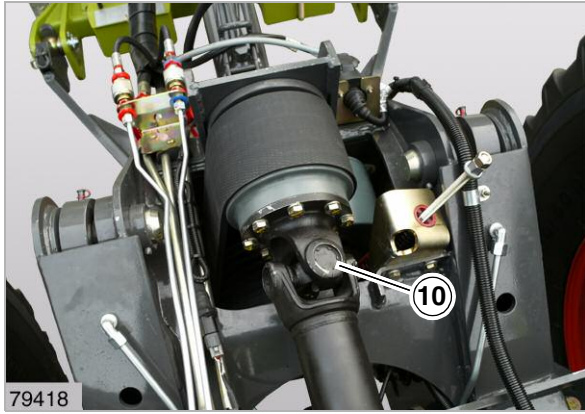

60

- Reinstall sealed passage for rotating shaft (9).
- Screw hydraulic hose connections to the sealed passage for rotating shaft.
- Screw universal drive shaft (10) to the top pulley again.
- Close vehicle hood.

(Fig. 55, 58–60)

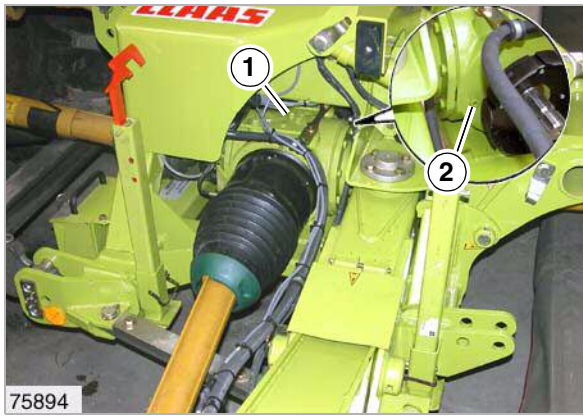

6

Checking oil level

- Remove the oil level check screw (2) and check the level of the oil in the gearbox.
- If required, add oil through the oil filling hole (1).

(Fig. 6, 7)

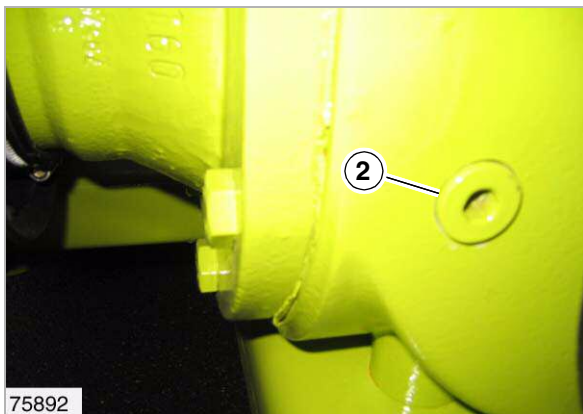

7

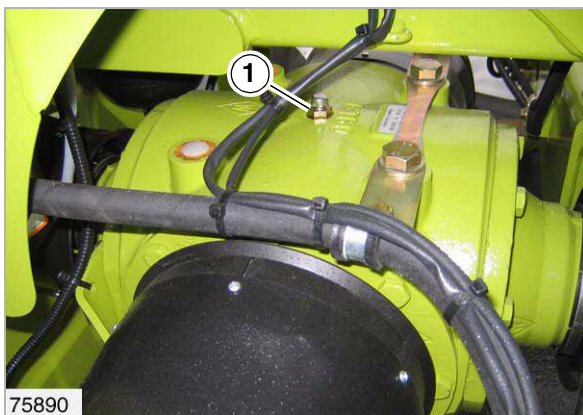

8

Venting valve

- Remove and clean the venting valve (1) in accordance with *Maintenance schedule - mower units*, page 314. Check the venting valve for satisfactory operation.

(Fig. 8)

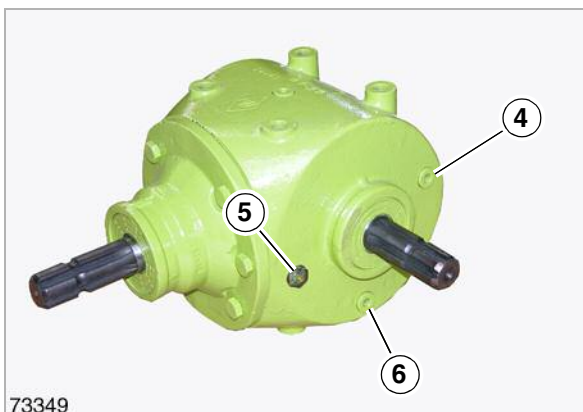

9

Main gearbox of front centre mower unit

Oil capacity

– see *Lubricant chart – mower units*, page 316.

Oil change

- Remove the right-hand universal drive shaft.
- Place container under oil drain plug (6) if required use suitable collection equipment to collect the oil.
- Replace the drain plug and tighten it to be oil-tight.
- Pour in the oil via the oil filling hole (4).
- Replace the universal drive shaft.

Front mower unit left / right

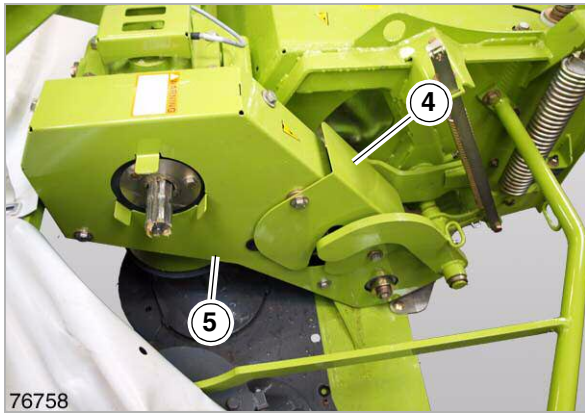

76758

30

- Remove guard (4) and guard (5).

Front mower unit left / right

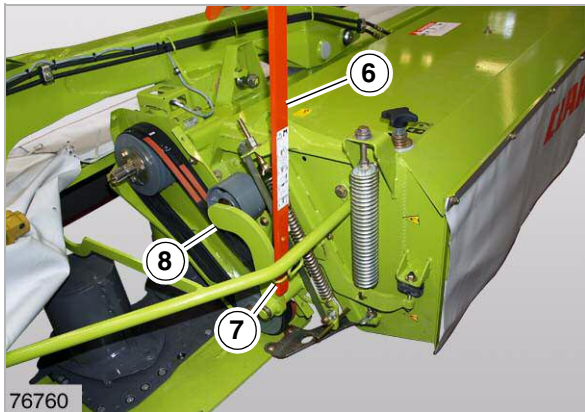

76760

31

- Push mounting lever (6) through the strap (7).
- Lift jockey pulley arm (8).
- Fix jockey pulley arm (8) in position with bolt (9).

Front mower unit left / right

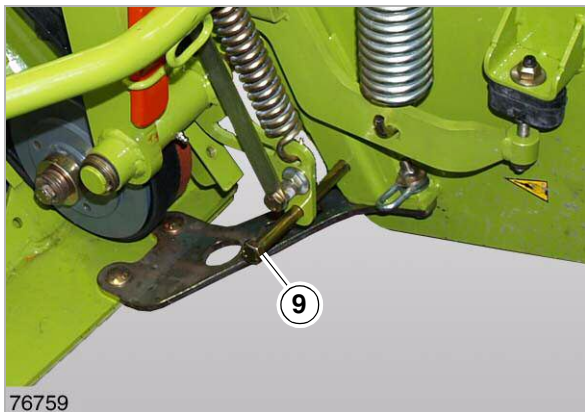

76759

32

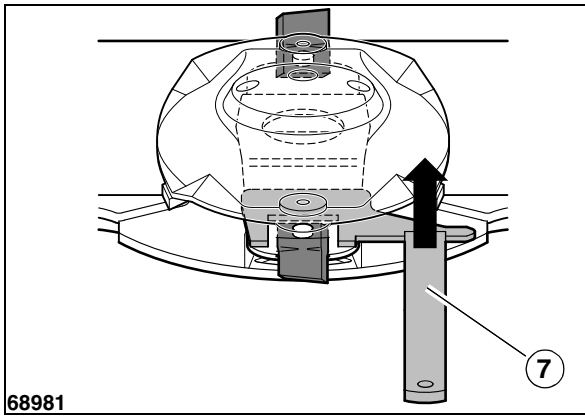

68981

58

- Release the mounting lever (7).



DANGER!

Extreme risk of injury by mower blades becoming loose!

- Ensure that the mower blades and blade mounting studs are fitted correctly. The blade mounting stud (11) must fit snugly (see arrow) and lie straight in the carrier hole of the cutter disc (6).

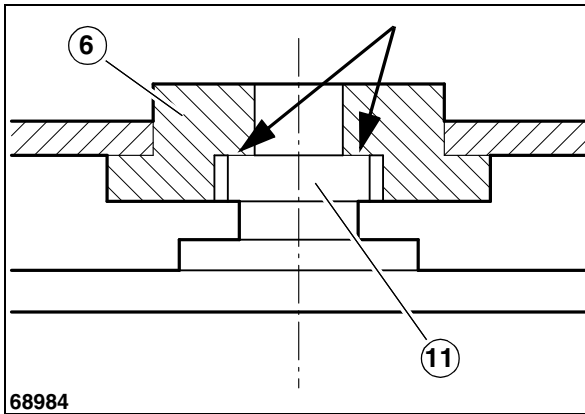

68984

59

(Fig. 58, 59)

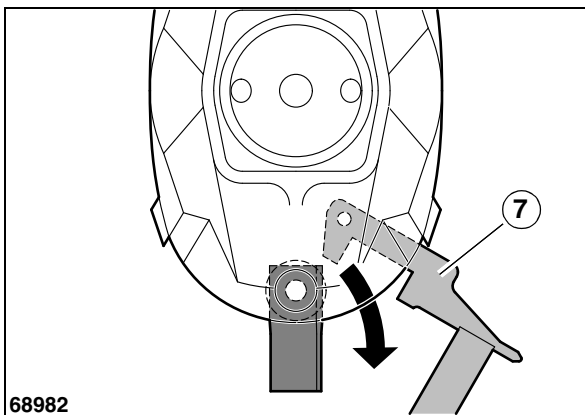

68982

60

- Remove the mounting lever (7) from the cutting disc.

(Fig. 60)

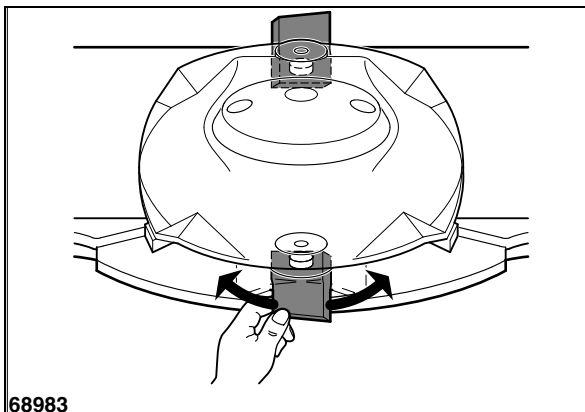

68983

61



DANGER!

Extreme risk of injury by mower blades becoming loose!

- Ensure that the mower blades and blade mounting studs are fitted correctly. The mower blade must be able to rotate freely and must be easily movable in both directions.

(Fig. 61)

Front centre mower unit, centre mower unit left / right

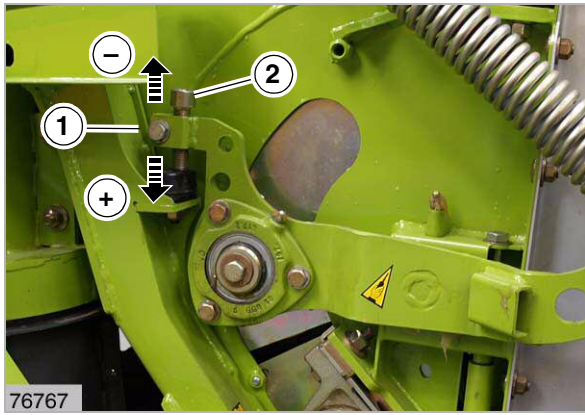

82

Front centre mower unit, centre mower unit left / right

- Release thumb screw (1).
- Adjust roller spacing with bolt (2).
- Tighten thumb screw (1).

Increase conditioning effect:

for stronger effect = adjust in direction (-)

for weaker effect = adjust in direction (+)

- Observe minimum spacing.



NOTE!

The conditioner rollers must be set to the same spacing on both sides!

Front centre mower unit, centre mower unit left / right

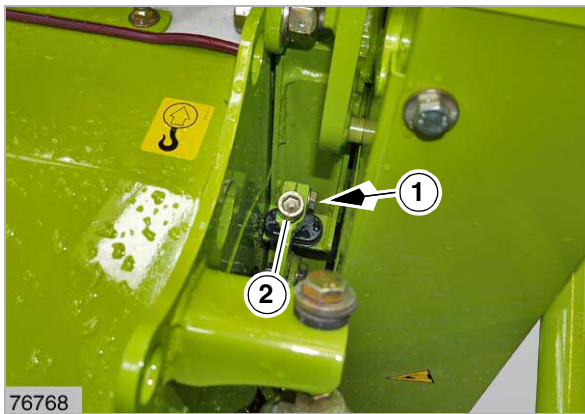

83

(Fig. 81, 82, 83)

Front mower unit left / right

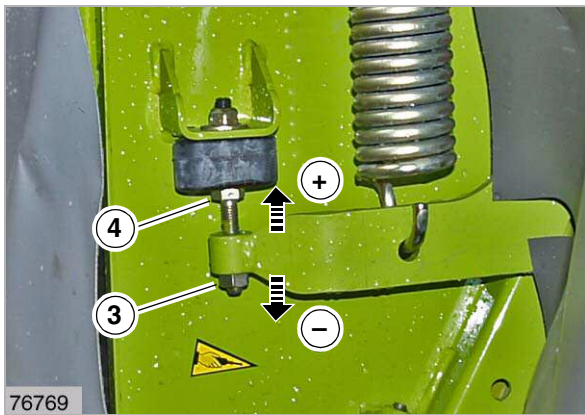

84

Front left and right mower unit

- Release nut (3).
- Adjust roller spacing with bolt (4).
- Tighten nut (3).

Increase conditioning effect:

for stronger effect = adjust in direction (+)

for weaker effect = adjust in direction (-)

- Observe minimum spacing.



NOTE!

The conditioner rollers must be set to the same spacing on both sides!

Front mower unit left / right

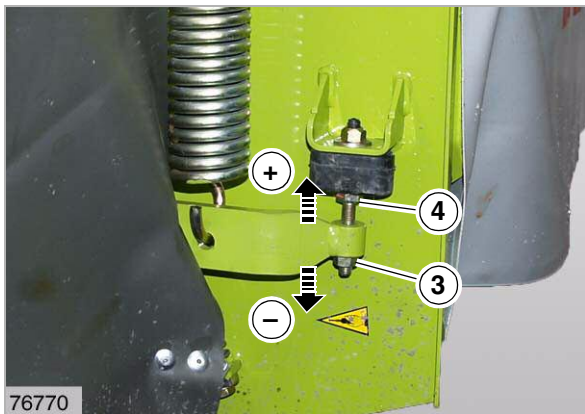

85

(Fig. 81, 84, 85)

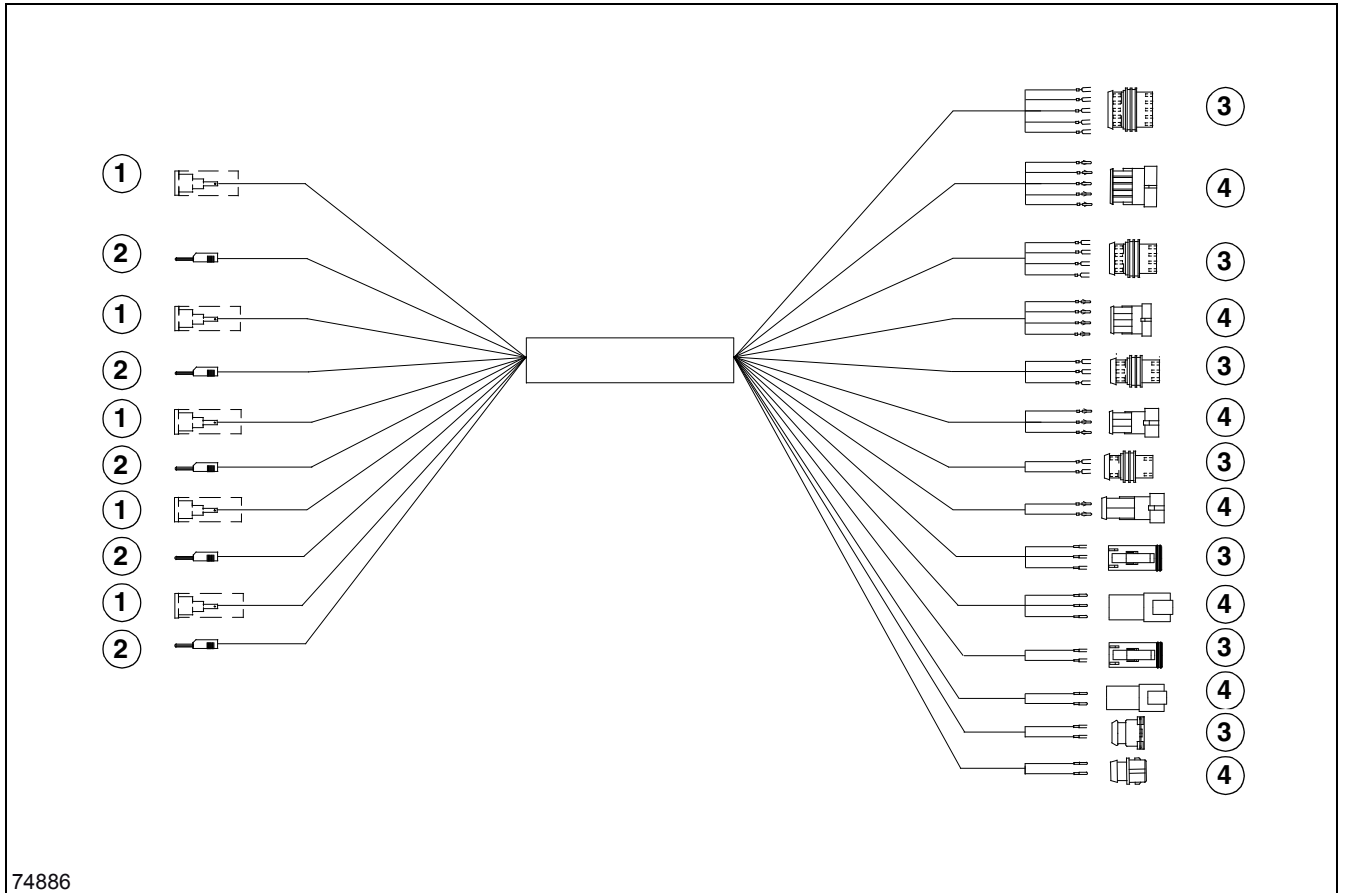

74886

13.15.5 Measuring cable

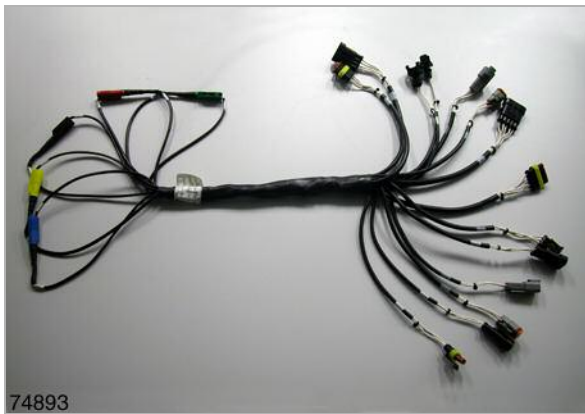

74893



CAUTION!

Checking of the sensor adjustment using a measuring cable must only be done by trained experts.

Danger of short-circuit!

- Only check one sensor at a time.
- Do not touch the plug (2) against any machine components.
- Only connect plugs (2) and sockets (1) of the same colour.

The measuring cable can be used to check the setting and function of the sensors. The individual connections (PIN's) of the plugs (4) (contact pins) and couplings (3) (contact sockets) are grouped together on the plugs (2) and the sockets (1).

Connections (PIN's):

- Contact pins / plugs (4) → Plugs (2)
- Contact sockets / couplings (3) → Sockets (1)

13.22 Cleaning and care

- Do not clean torque-overload couplings, bearing, hydraulic and electrical parts using high pressure jets or steam cleaners.
 - Danger of damage and rust formation.
- Cleaning at higher pressures can lead to paint damage.
- Grease the bearings before and after cleaning the machine with a high-pressure jet.
- Then carry out a short test run in order to press out any water which has entered the bearings.
- There must be a bead of grease at the bearing points. This protects the bearings from dirt, plant juices and water.
- If the machine is to be stored outdoors for a longer period, clean the piston rods of the hydraulic cylinders and lubricate with grease.
 - Remove the grease from the piston rods of the hydraulic cylinders before commissioning.

13.23 End of season storage

1. Clean dirt from mower units.
2. Drain oil from the angle drives and cutter bars and fill with new oil to the specified oil level.
3. Lubricate all lubrication points thoroughly until the grease comes out of the bearings (see lubrication chart). Run the mower units for a short time.
4. Check mower units for wear and damage and repair.
5. Remove V-belts and store safely in a dry place.
6. Clean all rust off mower units and touch up damaged paint.
7. COUGAR to be stored in a dry, weather-protected room where no fertilizer is stored.
8. Lower front centre mower unit to the ground.

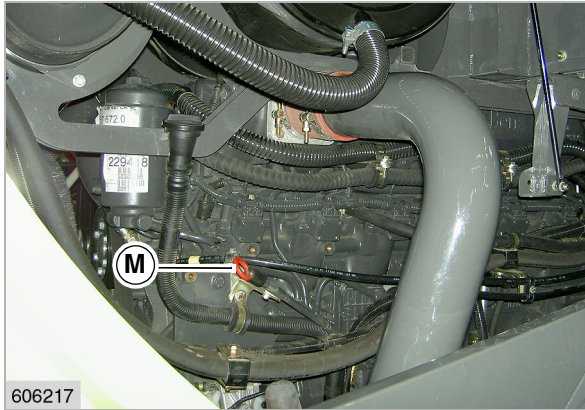

15

14.4.2 Engine oil level check

Check the engine oil level daily about 5 minutes after the engine has been switched off.

The oil dipstick (M) is located on the right hand side of the engine (looking from the cabin to the mower units).

The oil must not be higher than the FULL mark (maximum) and must not drop below the SAFE mark (minimum) on the oil dipstick.

Fill in only equivalent branded oil.

(Fig. 15)

14.4.3 Changing the engine oil



DANGER!

Be careful when draining hot oil – beware of burns!



ENVIRONMENT!

Dispose of drained oil in a manner that is harmless to the environment and in accordance with anti-pollution regulations!



NOTE!

The prescribed type of oil and the change intervals are shown in the lubricant table or the maintenance table.

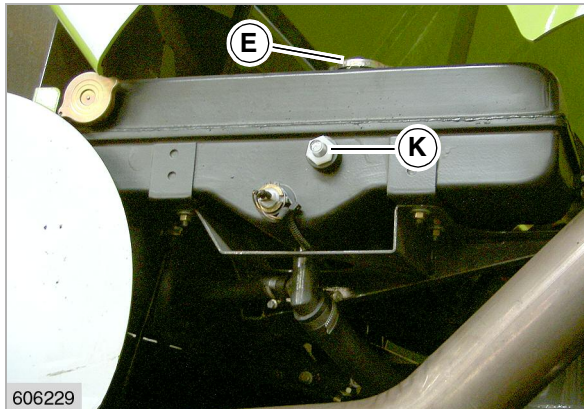

27

14.5.8 Topping up coolant



DANGER!

When the engine is hot, the cooling system is pressurised – **Danger of burns!**

- Let engine cool down before draining the coolant!
- Only loosen the radiator cap up to the stop and allow the excess pressure to escape first!



ATTENTION!

Mixed coolants change their properties.

Coolants can flocculate. Engine overheating.

– see **Observe coolant type**, page 385

Coolants in accordance with DC Sheet 325.0 and DC Sheet 325.2 must not be mixed with coolants in accordance with DC Sheet 325.3 and CAT EC325-1.

After new filling of the air conditioner with a coolant in accordance with DC Sheet 325.3 or CAT EC-1, the sticker with Part no. 00 0516 622 1 must be affixed.

- Unscrew the radiator cap (E).
- Pour coolant in through the pouring spigot at (E) up to water level sight glass (K).



NOTE!

The expansion vessel should always be filled to the sight glass (K).

Never pour cold water into a hot engine. – Use only clean water containing little lime and chlorine, from a clean container.

- Screw the radiator cap (E) back tightly.
- Start the engine and allow to run for a while.
- Stop the engine and let it cool down.
- Check the coolant level and top up coolant if required.

(Fig. 27)

Malfunction	Possible cause or remedy
Battery terminals corroded.	<ol style="list-style-type: none">1. Keep terminals clean (do not use a scraper)2. Grease the terminals (vaseline).
Connectors corroded.	<ol style="list-style-type: none">1. Remove battery. Clean the connectors with ammonia, rinse and dry.
Battery acid boils over.	<ol style="list-style-type: none">1. Check acid level.2. Check operation of three-phase regulator and replace if required.3. Check battery.
Battery dirty.	<ol style="list-style-type: none">1. Remove battery. Clean the terminals and the surface with water and a brush.

**CAUTION!**

Do not place any metal components on the battery. Self-discharge, **DANGER OF FIRE!**

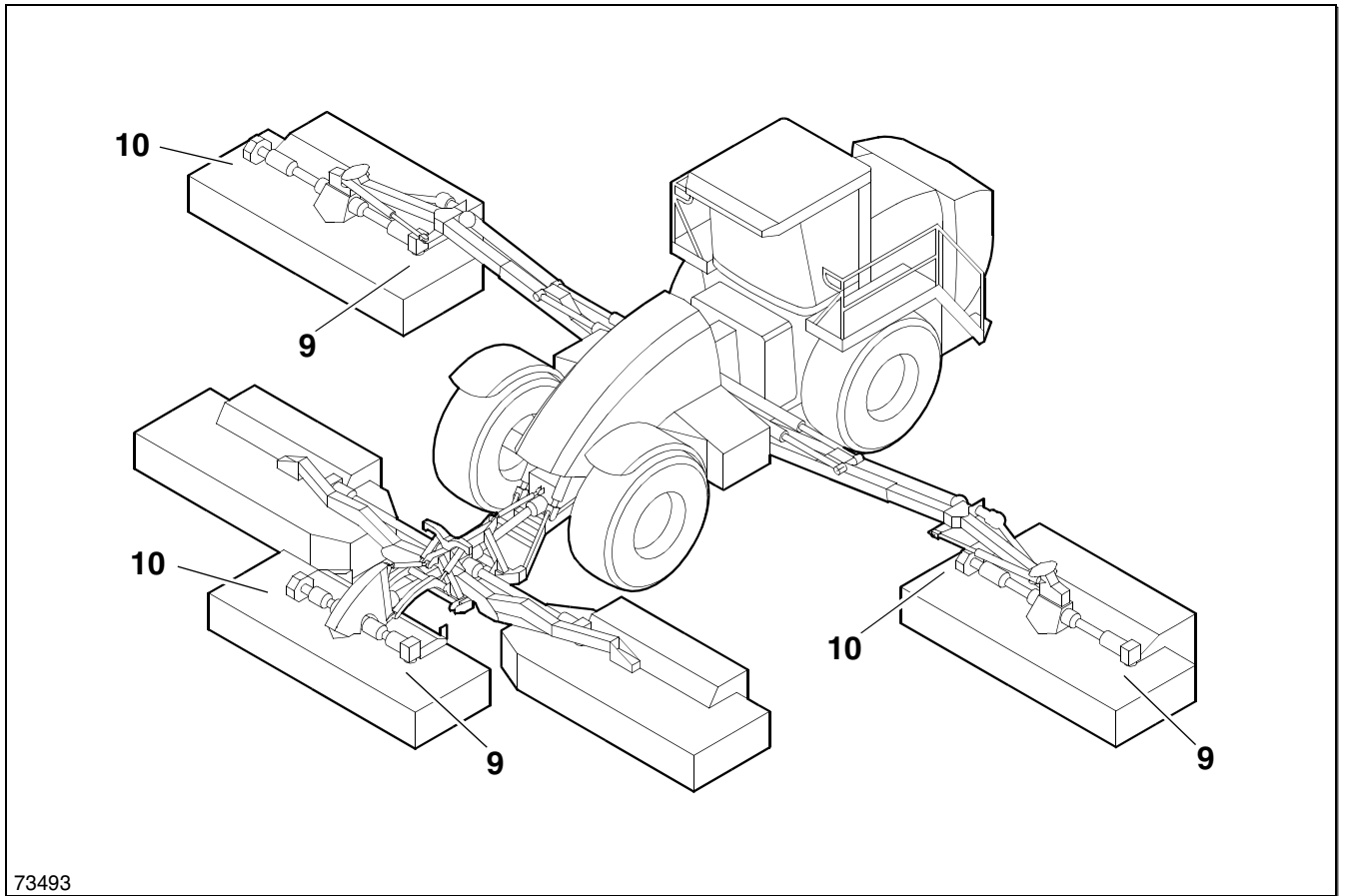

73493

COUGAR 1400 RC

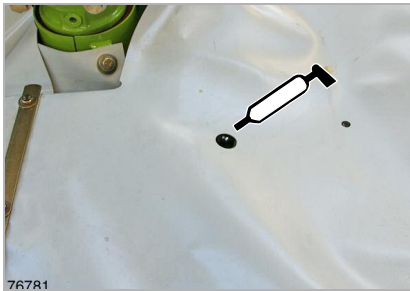

76781

9

COUGAR 1400 RC

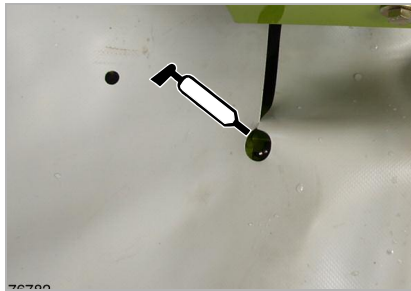

76780

10



CLICK HERE TO **DOWNLOAD** THE COMPLETE MANUAL

- Thank you very much for reading the preview of the manual.
- You can download the complete manual from: www.heydownloads.com by clicking the link below



- Please note: If there is no response to CLICKING the link, please download this PDF first and then click on it.

CLICK HERE TO **DOWNLOAD** THE COMPLETE MANUAL