

Operator's Manual

*Challenger*<sup>®</sup>

## Applicator Chassis

### **RG1100B**

AGCC1100xFxxx1001-

### **RG1300B**

AGCC1300xFxxx1001-



North America

4205 River Green Parkway, Duluth GA 30096 USA

Challenger is a registered trademark of Caterpillar Inc. and is used under license by AGCO.

© AGCO 2018

Original Operator's Manual

October 2018

572677D1J

EAME

English

CLICK HERE TO **DOWNLOAD** THE COMPLETE MANUAL

- Thank you very much for reading the preview of the manual.
- You can download the complete manual from: [www.heydownloads.com](http://www.heydownloads.com) by clicking the link below



- Please note: If there is no response to CLICKING the link, please download this PDF first and then click on it.

CLICK HERE TO **DOWNLOAD** THE COMPLETE MANUAL

## 1.1 A word to the operator

It is your responsibility to read and understand the safety section in this manual and the manual for all implements before you operate this machine. You are responsible for your safety. Good safety procedures prevent injury to you and the persons around you.

Make the information in the safety section of this manual a part of your safety procedure. This safety section is written only for this type of machine. Safety is your responsibility. You can prevent injury and death.

This safety section gives basic safety examples that can occur during the operation and maintenance of your machine. This safety section is not a replacement for safety instruction in other sections of this manual.

Injury or death can occur if the safety instruction is not obeyed.

Learn how to operate the machine and how to use the controls correctly.

Do not operate the machine if you do not know how to operate the machine. Do not let persons operate the machine that do not know how to operate the machine.

Follow all safety instructions in the manuals and on the safety signs on the machine, the implements, and the attachments.

Use only approved attachments and implements.

Make sure that your machine has the correct equipment that is necessary by the local regulations.

**WARNING:**

**Do not use alcohol or drugs that can have an effect on alertness or coordination. If you use prescription or 'over the counter' drugs, get medical advice about the safe operation of machines.**

**CAUTION:**

**If attachments or implements used with this machine have a different operator manual, see that operator manual for other important safety instructions.**

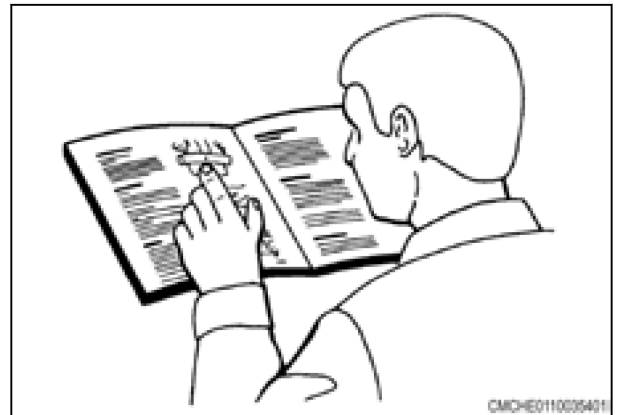

Fig. 1

- Stop the engine and remove key.
- Let the machine cool.
- Keep all parts in good condition and correctly installed.
- Repair any damaged machine systems and or components immediately.
- Replace worn, damaged or broken parts immediately.
- Remove any buildup of grease, oil or debris.
- Disconnect electrical system before making adjustments or welding on machine.



Fig. 18

### 1.3.2 Chemical safety



**DANGER: Chemical safety hazard.**  
**Personal injury or death can occur.**

**Wear manufacturer recommended personal protective equipment when handling hazardous chemicals. Potentially dangerous chemicals used with the equipment include items such as fuel, lubricants, coolant, hydraulic fluid, paints and adhesives in addition to the agricultural chemicals being applied.**

Always wear approved protective equipment and clothing recommended by the chemical manufacturer.

Before reloading the machine, wear personal protective equipment as required by pesticide use instructions and the chemical manufacturer recommendations. Before entering the cab, remove protective equipment. Store protective equipment outside the cab in a closed box or another type of sealable container. Clean any shoes or boots to remove soil or other contaminants before entering the cab.

If dangerous chemicals come in contact with the body, wash immediately according to the chemical manufacturer's recommendations.

Never put nozzles, tips or other parts to lips to blow out trash or debris. Have spare tips available for replacement.

Wear close fitting clothing and correct safety equipment required.

Wear approved hearing protection such as earmuffs or earplugs to protect against loud noises.

Long exposure to high noise levels can cause hearing impairment.



Fig. 19

### 1.5 Electrical safety signs

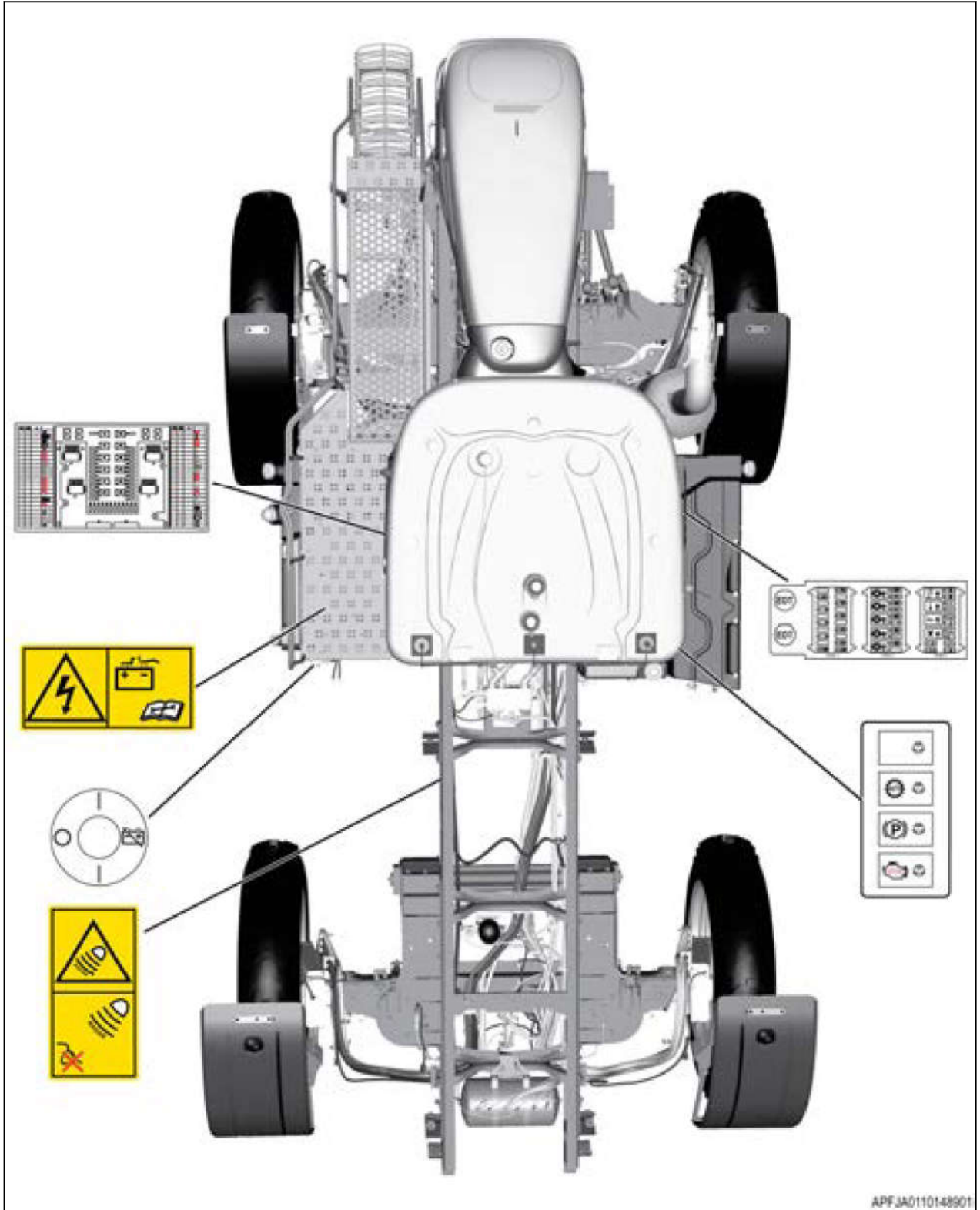



Fig. 32

### 1.8.1 Read manual

Read manual	
	<p>Read and understand the operator manual before operating the machine.</p>

### 1.8.2 Park brake

Park brake	
	<div style="display: flex; justify-content: space-between;"> <div style="text-align: center;">  </div> <div> <p>When the park brake is released, the machine does not have any park brake function. Block the wheels to prevent the machine from moving, which can cause serious injury and damage to the components.</p> <p>Always engage the park brake and turn off the engine before servicing or adjusting.</p> </div> </div>

### 1.8.3 Electrical hazard

Electrical hazard	
	<div style="display: flex; justify-content: space-between;"> <div style="text-align: center;">  </div> <div> <p>When raising or lowering the booms be aware of electrical lines.</p> <p>Never let the machine contact overhead power lines. To prevent contact, bend the radio antenna down and secure during operation or transport. Do not park, service, and or repair the machine under overhead power lines.</p> </div> </div>

### 1.8.4 Break glass - exit

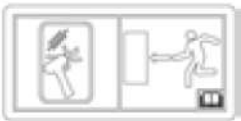
Break glass - exit	
	<p>Understand the procedure to use the emergency exit. Remove the hammer provided, and break the glass.</p>

Code	Definition	Code	Definition
E	2014	L	2020
F	2015	M	2021
G	2016	N	2022

*Model year code definition*

Code	Definition
0	No code
S	Single system
C	Combo unit

*Position 8 option code definition*

Code	Definition
0	No code
L	RG liquid
3	Air Max 180
N	New Leader
C	Custom

*Position 9 option code definition*

(2) RTMR2	
Relays	Fuses
Auxiliary 1	Auxiliary 1 (10 amp maximum)
	Work light module clean power D
Auxiliary 2	Auxiliary 2 (10 amp maximum)
	Head light module clean power D
Auxiliary 3	Auxiliary 3 (10 amp maximum)
	Input/output module #1 clean power
Auxiliary A	Auxiliary A (15 amp maximum)
	Engine unswitch power
Auxiliary B	Auxiliary B (15 amp maximum)

(3) RTMR3	
Relays	Fuses
GPS / controller switch relay NOx sensor	Keypads
	Dash
Sensor switch power	GPS unswitch power clean
	GPS switch power clean
Horn	Controller power switch clean
	Sensor switch power clean
High voltage detection system	Controller power unswitch clean
	NOx sensor / quality sensor switch
Clean power sensor - press switch	Rexroth clean controller
Clean power sensor - fuel / hydraulic	HVDS/Sparger cab indicator

### 2.6.2 Fuse/relay panel

The fuse/relay panel location is on the left-side of the operator's seat below the instructor's seat (3). Remove the wing screws (1) and the electrical cover (2) to get access to the fuse/relay panel.

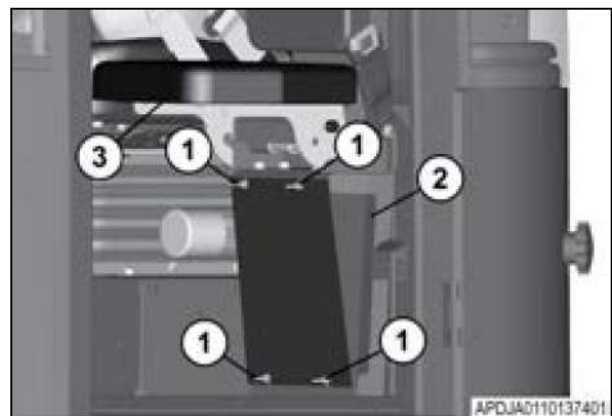

Fig. 17

## 3 Operation

<b>3.1</b>	<b>Drive the machine</b>	<b>73</b>
3.1.1	Checklist before starting engine	73
3.1.2	Battery disconnect switch	73
3.1.3	Grid air heater symbol	74
3.1.4	Cold weather starting procedure for hydrostatic system	74
3.1.5	Cold start option	75
3.1.6	Restart a stalled engine	75
3.1.7	Drive the machine	75
3.1.8	Weight regulated shifting	76
3.1.9	RG1300 down shift logic	76
3.1.10	RG900 / RG1100 / RG1300 pressure compensated drive system	77
3.1.11	Speeds and terrain	77
3.1.12	Engine power limitations	78
3.1.13	Stop the engine	78
3.1.14	Remote throttle	78
3.1.15	Machine braking	79
3.1.16	Backup alarm	80
<b>3.2</b>	<b>Machine management center</b>	<b>81</b>
3.2.1	Home screen display	81
3.2.2	System configuration	82
3.2.3	Machine persistent area	82
3.2.4	Information boxes	82
3.2.5	Select the about information	83
3.2.6	Select the engine information	83
3.2.7	Select the transmission information	84
3.2.8	Select the tire size information	85
3.2.9	Select the radar calibration information	86
3.2.10	Select the fuel information	87
3.2.11	Select the track adjust information	88
3.2.12	Select the settings information	89
3.2.13	Select the active error codes diagnostics information	93
3.2.14	Select the stored error codes information	93
3.2.15	Operate the foam marker	94
3.2.16	Select the four wheel steer information	97
3.2.17	Maintenance schedule screen	99
3.2.18	Change the measuring units	100
3.2.19	Operational messages	101
<b>3.3</b>	<b>Instruments and controls</b>	<b>104</b>
3.3.1	Dash panel	104
3.3.2	Hydrostat control - 5 section boom	106
3.3.3	Hydrostat control - 7 section boom	107
3.3.4	Shift switch buttons	108
3.3.5	Armrest switches	108
3.3.6	Chassis keypad	110
3.3.7	System keypad	111
3.3.8	Adjust the mirrors	111
3.3.9	Map and dome light	113
3.3.10	Radio (if equipped)	113
3.3.11	Sun Visor	113
3.3.12	Cup holder	114
3.3.13	Storage compartments	114

### 3.2 Machine management center

Location where the Machine Management Center display mounts in the cab.

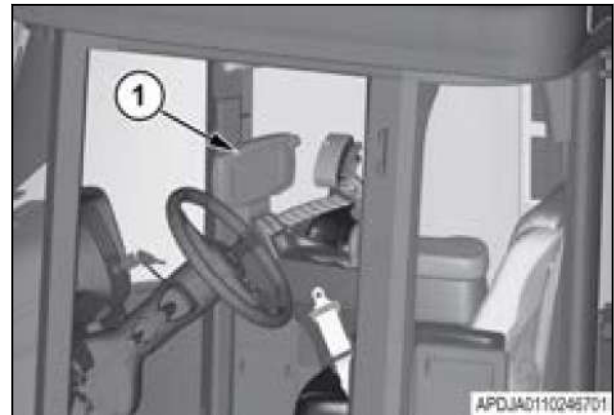

Fig. 10

Machine Management Center display

**IMPORTANT:** Software icons will vary per machine.

- (1) Rotate the scroll wheel to change to the desired icon.
- (2) Press in and release the scroll wheel to select the desired icon.
- (3) Desired icon location on the main screen of the machine management center display.
- (4) Use a key to select the desired icon.

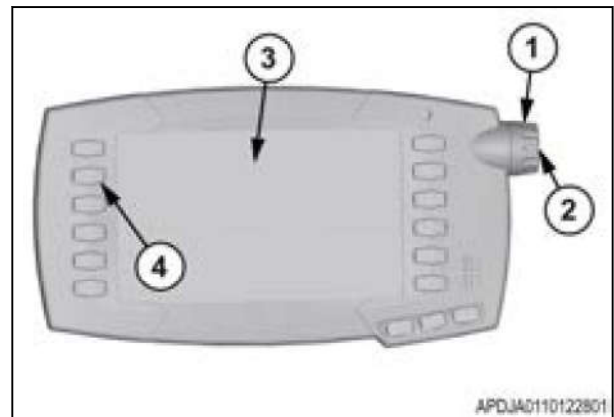

Fig. 11

#### 3.2.1 Home screen display

**IMPORTANT:** The home screen can be different according to the software installed.

The applicator icon (1), when selecting [show icon], has the following screens available:

- Engine
- Transmission
- Fuel
- Speed source
- Settings
- Active codes
- Stored codes
- Foam marker, if equipped
- GatorTrak 4-wheel steer, if equipped

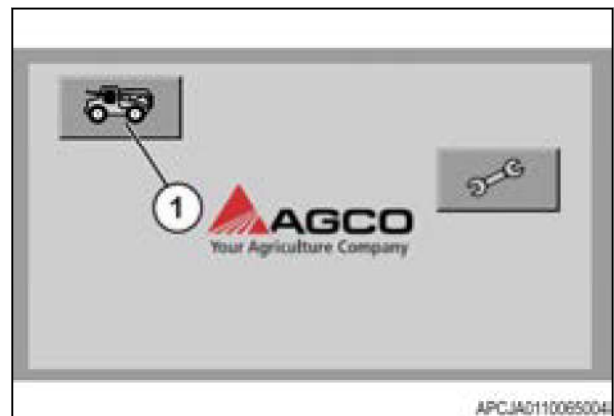

Fig. 12

**Adjusting the delayed lighting shutdown**

- 10. Select the delayed lighting shutdown icon (1).
- 11. Use the scroll wheel to adjust settings (2).
- 12. Press in and release the scroll wheel to keep the changes.

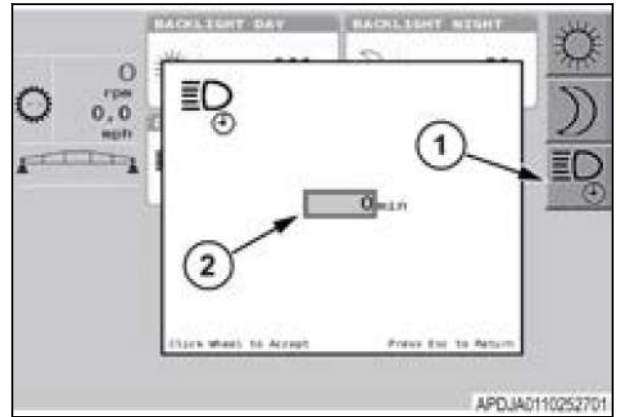

Fig. 40

**Adjusting the terminal audio level and illumination**

- 13. Select the setting icon (1) from the terminal home screen.
- 14. Press in and release the scroll wheel.

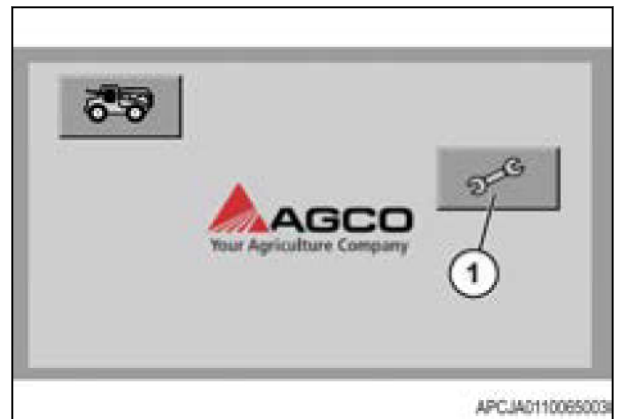

Fig. 41

- 15. Select the terminal settings by scrolling to the terminal settings box (1). Press the scroll wheel button to select it, or press the button next to the terminal settings icon (2).



Fig. 42

3. Select regional settings (1), then push the center of the scroll wheel.



Fig. 70

4. Select units (1), then push the center of the scroll wheel.

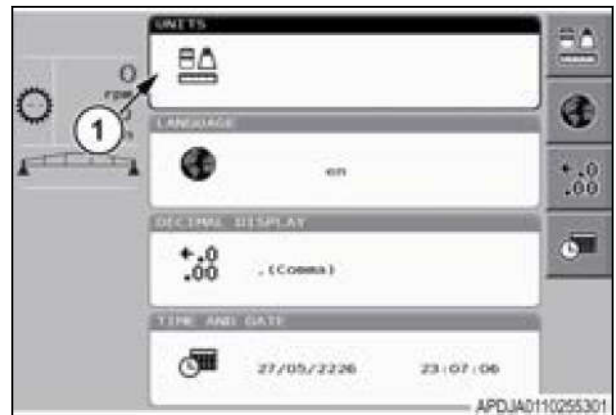

Fig. 71

5. Choices are available for imperial, metric, and U.S. measurement units.
6. Selections made in upper portion of screen (1) will change all measurements to the selected type of measurement units, if available.
7. Selections made for groups of measurement (2) will show in measurement units specified.

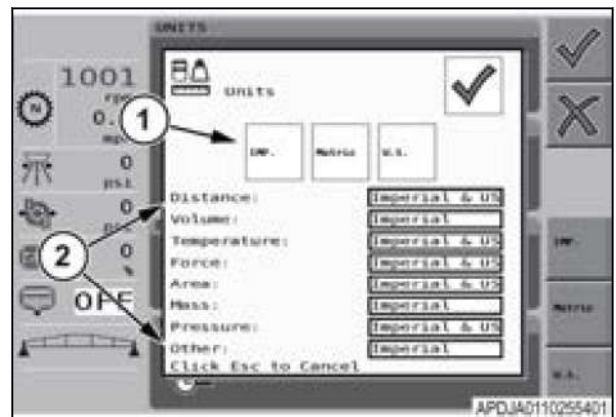

Fig. 72

### 3.2.19 Operational messages

The messages conveying information regarding function issues will show on the Machine Management Center (MMC).

### 3.3.7 System keypad

System keypad located on right rear "B" post of the cab, below the chassis keypad.

1. **Full boom break-away return** - If booms do not return to normal operating position use control to move the booms into position. Only equipped with liquid system booms.
2. **Roll tarp close** - Push switch to close roll tarp. If system equipped with a roll tarp.
3. **Roll tarp open** - Push switch to open roll tarp. If system equipped with a roll tarp.
4. **Main boom shut off valve** - shut off product to booms. If equipped with liquid system - Only available with boom cleanout option.
5. **Boom cleanout** (if equipped with liquid system - optional)
6. **Dual foam marker** - Press switch to let run from both booms. Selection switch on hydrostatic control handle must be in left or right position for dual switch to operate. If equipped with foam marker.
7. **Boom cradle unlatch** - Press and hold the switch to unlock the latch. Only equipped with AirMax 180 system.

**NOTE:** Make sure that the boom cradle latch is unlocked before extending the boom, damage can occur.

8. **Boom cradle latch** - Latch boom after putting boom in cradle. If equipped with AirMax 180 system.

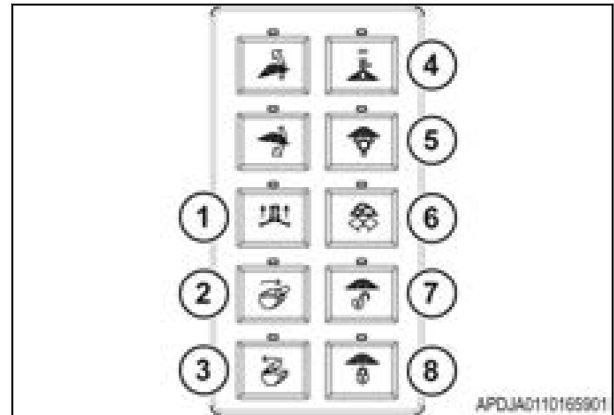

Fig. 88

### 3.3.8 Adjust the mirrors

Because of the application system booms, the operator must use all four mirrors to see all objects behind the machine.

#### Left side mirror

Left side mirror (1) and boom rest mirror (2).

**IMPORTANT:** If equipped with the Air Max 180 system, the left side mirror (1) must be in the lower position (3) on the mounting post. For other systems, the left side mirror can be in the upper position (1).

**NOTE:** The boom rest and the boom rest mirror can vary with machine options.

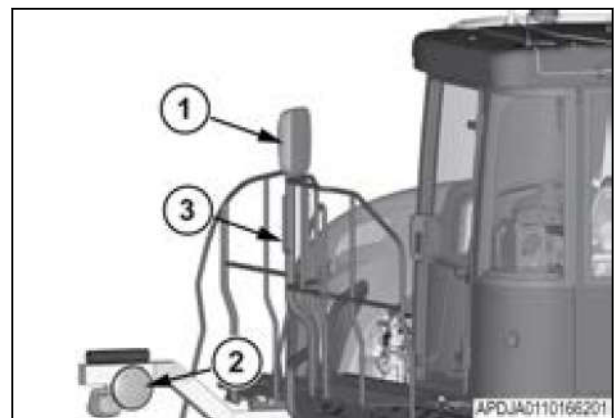

Fig. 89

### 3.4 Temperature control

**NOTE:** When the unit is on, the digital display illuminates and shows the current set point temperature.



Fig. 109

Reference	Mode	Description
1	On/Off	Controls on and off for the heater - A/C control system. The display shows the current set temperature.
2	Auto	The automatic temperature control mode, including automatic fan speed control, adjusts blower fan speed to lowest setting necessary to hold the selected temperature.
3	Defrost	Lets the A/C system remove moisture from the cab. A/C is enabled even if temperature is set to heat.
4	Fan Up/Down	The display indicates the fan speed setting as a percentage of HI (maximum) or LO (minimum) when fan speed is reached. Then the display returns to normal display five seconds after either key is pressed. The set fan speed is maintained until changed or the auto key is pressed.
5	Temperature Up/Down	Arrows indicate up/down to set temperature.
6	ECON	The ECON when pressed, will lock out A/C function, and when pressed again will return system back to normal operation.
7	C/F	Switches between Celsius and Fahrenheit

#### 3.4.1 Heater operation

Automatic Temperature Control (ATC) automatically controls the cab heating and cooling system to hold cab air temperature at temperature selected. ATC will adjust the temperature of the air blowing through

An instructor seat with the back cushion in the lowered position (1).



Fig. 117

CLICK HERE TO **DOWNLOAD** THE COMPLETE MANUAL

- Thank you very much for reading the preview of the manual.
- You can download the complete manual from: [www.heydownloads.com](http://www.heydownloads.com) by clicking the link below



- Please note: If there is no response to CLICKING the link, please download this PDF first and then click on it.

CLICK HERE TO **DOWNLOAD** THE COMPLETE MANUAL

### 3.11 Air dump valve

**WARNING:**

Before doing tasks or maintenance in this area of the machine make sure that the parking brake is engaged, the engine is off, and the key has been removed from the ignition.

**IMPORTANT:**

Before trailering the machine, remove the air from the air spring bags. Attach the machine correctly.

The air dump valve (1) is by the left rear air spring.

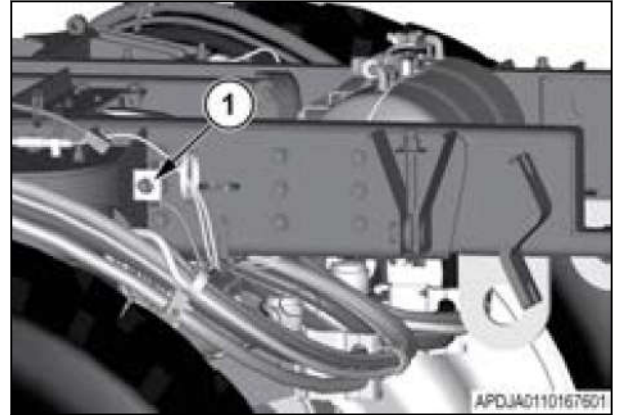

Fig. 133

The air dump decal is put around a manual air dump valve by the left rear air spring. The air dump valve controls if the air spring bags are filled with air or not.

The up arrow (valve closed) is to fill the air spring bags for correct operation and the down arrow (valve opened) is to deflate the air spring bags for trailer transport.

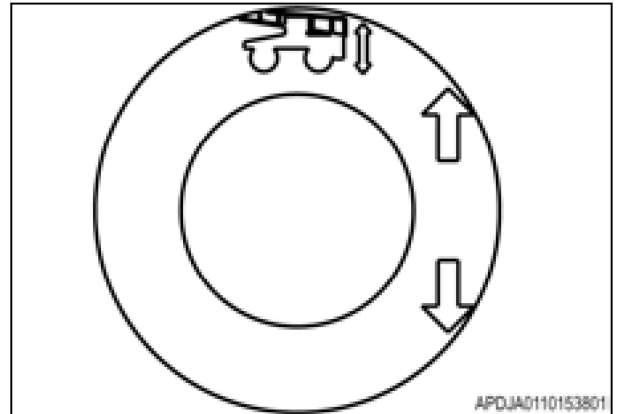

Fig. 134

### 3.14.3 Operate the pressure washer

#### Before starting the procedure

**WARNING:**

Water discharges from this device at very high pressure. Do not point the spray wand at persons or a part of the human body. High-pressure water can result in severe personal injury. When using the pressure washer, wear goggles or a face shield to prevent damage to the eyes from spray or materials that can be loosened and spatter during cleaning.

**NOTE:** Do not operate the pump for longer than two minutes without pulling the trigger. Long periods of operation of the pump without using the wand increases the temperature of the liquid and can damage the seals.

#### Procedure

1. Open the pressure washer cabinet door.
2. Make sure that the hose is connected to the reel (1).
3. Pull the quick release pin (2) to release the handle.
4. Turn the handle (3) while pulling to unwind the hose.
5. Remove the pressure washer spray wand (1) and connect the end to the hose for spraying.

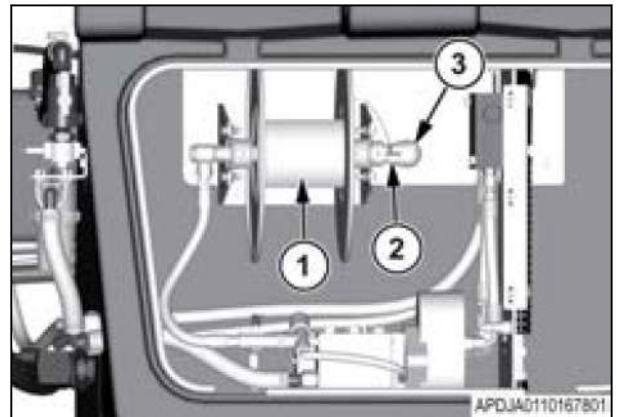

Fig. 149

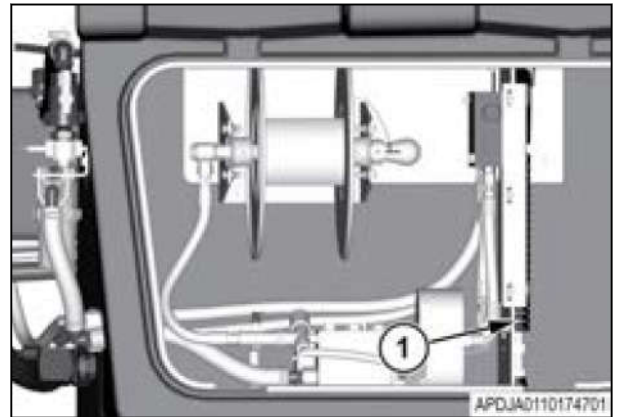

Fig. 150

## 4.2 Maintenance schedule

### 4.2.1 Rogator engines

Different engine sizes are used in the Rogator depending on the model. Engine maintenance is different between the models.

Rogator Models	Engine models
RG700B	49
RG900B	74
RG1100B / RG1300B	84

### 4.2.2 Maintenance chart

Maintenance chart for engine models 84 AWF and 98 AWF used in RoGator, TerraGator and MT700 series tractors.

#### 84 AWF and 98 AWF

Maintenance work	Service interval / running hours				
	10	100	400	800	4500
Check the engine oil level	x <sup>[1]</sup>				
Check the coolant level	x <sup>[1]</sup>				
Check for oil, fuel or coolant leakages	x <sup>[1]</sup>				
Clean the cooling system (from outside)		x			
Check the condition of the belt		x			
Change the engine oil and the oil filter			x <sup>[2]</sup>		
Change the fuel filters				x <sup>[3]</sup>	
Do a check for a possible engine software update <sup>[4]</sup>			x		
Adjust the valves <sup>[5, 6]</sup>	See the valve adjustment intervals table.				
Turbocharger and intercooler inspection in a repair workshop					x
Change the coolant	Every two years.				
Change the vibration damper (98 engines)	Every five years. <sup>[7]</sup>				

[1] or once a day.

[2] or once a year (at the end of the season).

[3] or once a year (at the end of the season) or earlier if the engine control system notifies by specific service code.

[4] Always do an engine software update, if there is an update available.

[5] The 98 engines have hydraulic lash adjusters from the engine serial number B52904. Do not adjust the valves.

[6] In the spring 2016, AGCO Power started to install hydraulic lash adjusters gradually to different 84 AWF engines. See for information, how to recognize an engine with hydraulic lash adjusters. Do not adjust the valves of an engine, which has hydraulic lash adjusters!

[7] or after 8000 running hours.

9. Install the air filter cover (2).
10. Latch the four clips (1) to attach to the air filter cover.

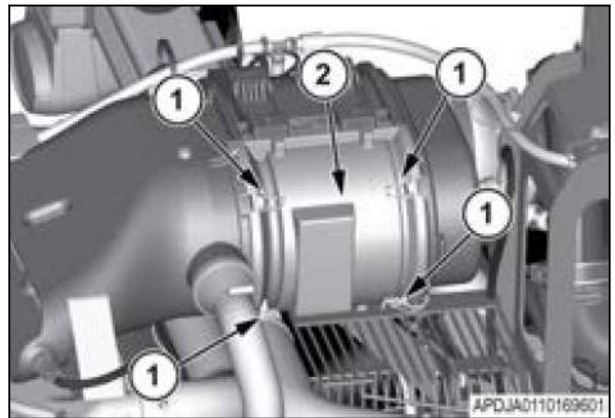

Fig. 16

11. Reset the service indicator by pressing the button (1) on the indicator.
12. Do a check of the connections between the air filter cover and the engine to make sure that they are tight.
13. Do a check of the connections between the air filter and the engine to make sure that there are no leaks.
14. Close the engine cover and connect the two engine cover latches.



Fig. 17

### 4.3.6 How to recognize an engine with hydraulic lash adjusters

**IMPORTANT:** Do not adjust the valves of an engine, which has hydraulic lash adjusters!

An engine with hydraulic lash adjusters has a cylinder block, which has drillings for oil ways for each hydraulic lash adjuster. If the cylinder block has oil ways, there are screw plugs on the oil ways in the cylinder block.

The screw plugs are in the same locations, where the hydraulic lash adjusters or valve tappets are. For example, one location is above the engine plate.

- (1) Screw plug

**NOTE:** The same cylinder block is used in some engines, which do not have the hydraulic lash adjusters.

#### Procedure

1. Examine the cylinder block for screw plugs on oil ways.

#### Result

If the cylinder block has no screw plugs, the engine does not have hydraulic lash adjusters.

2. If the cylinder block has screw plugs, examine the screw head of the screw plug.

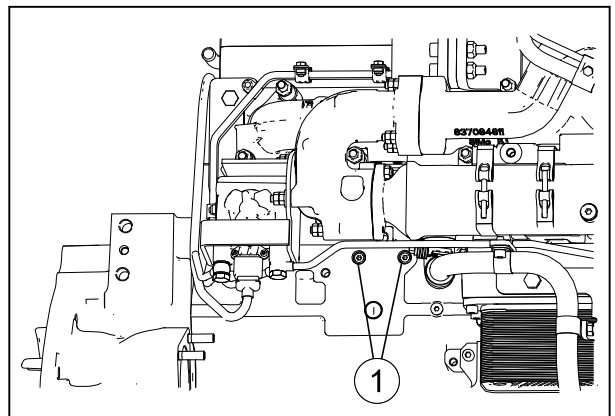

Fig. 18

## 4.7 Hydraulic system

### 4.7.1 Hydraulic system

Make sure the hydraulic fluid level is correct every day.

Keep the oil level to the FULL lines on the sight gauge.

Examine the hydraulic components, hoses, tube lines, and fittings for damage and leaks daily.



**WARNING:**

**Do not open the hydraulic tube lines or hoses that are under pressure. Never use hands to examine for leaks. Hydraulic oil under pressure can cause injury or death.**

Hydraulic fluid should be changed every 500 hours of operation or annually.

### 4.7.2 Do a hydraulic oil-level check

#### Procedure

1. Park the machine on a solid, level surface.
2. Fold the booms in and put into the boom rests.
3. Apply the parking brake, stop the engine, and take the key with you.
4. Let the hydraulic oil cool.
5. Examine the sight gauge (1) and make sure that the hydraulic oil level is at the cold temperature level.

**NOTE:** *If the hydraulic oil level is below the cold temperature level, add hydraulic oil.*

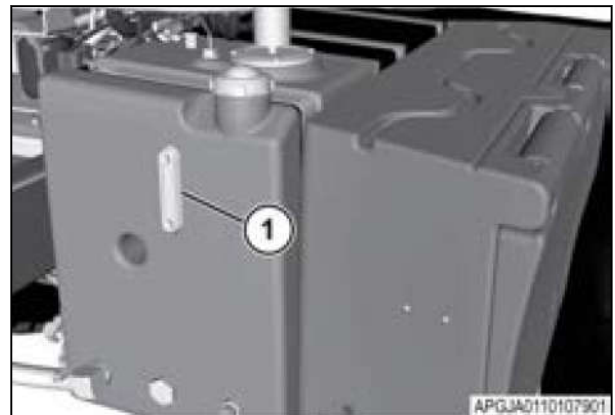

Fig. 38

#### Related Links

[Lubricants and fluids](#) page 159

### 4.8.5 Remove the battery



**WARNING:**

A lead acid battery will generate flammable and explosive gases. Keep sparks and flames away from battery.

Sulfuric acid in battery electrolyte is poisonous. It is strong enough to burn skin, eat holes in clothing, and cause blindness if splashed into eyes.

If acid contacts eyes, skin or clothing, flush with water immediately. If acid contacts eyes get immediate medical help.

**Procedure**

1. Rotate key (1) counterclockwise to disconnect battery power. Remove key (1).

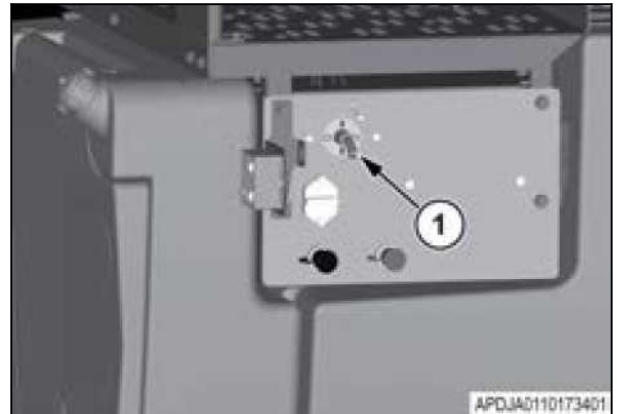

Fig. 56

2. Remove four screws (1) to remove battery cover access panel (2).

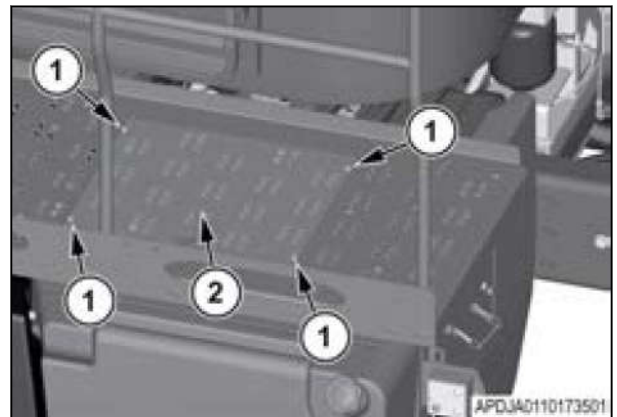

Fig. 57

3. Remove four bolts and washers (1) to remove inside battery box cover (2).

**IMPORTANT:** Clean any dirt or debris from the top of battery box before removing.

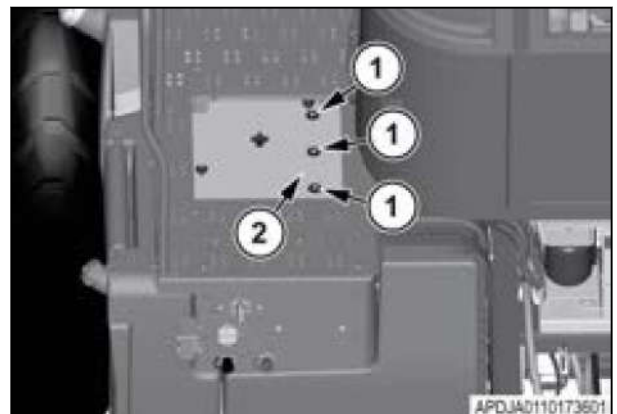

Fig. 58

3. Remove primary air filter.

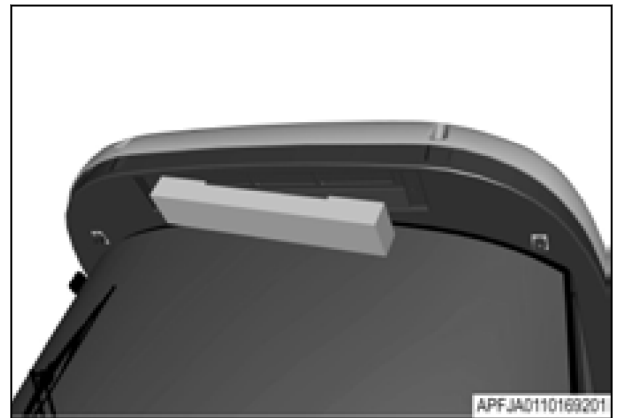

Fig. 79

4. Install the new primary air filter with the airflow arrow on filter pointing up for proper operation.

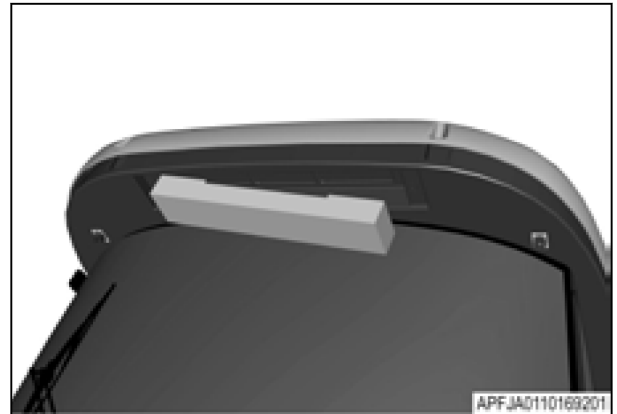

Fig. 80

5. Lift panel into position and tighten thumbscrew (1).

**NOTE:** Make sure the seals come in contact with surface to eliminate air bypass.

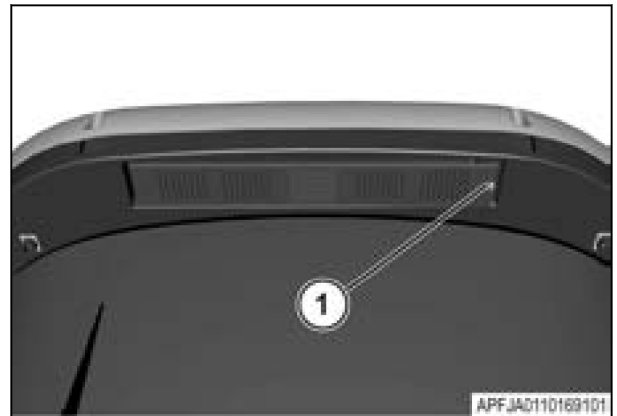

Fig. 81

#### 4.10.4 Change the secondary clean air filter

The secondary clean air filter is carbon-based.

**NOTE:** Install the filter immediately when removed from the protective packaging, if applicable. Exposure to the environment decreases the effectiveness of the filter.

Axle weights for different machine configuration lb/kg						
Model	Tank Size Liters / (Gallons)	Boom Length meter / (ft)	Water		28 Percent Nitrogen	
			Front	Rear	Front	Rear
RG900	3407 liter (900 gal)	<= 30.5 m (100 ft)	7099 kg (15650 lb)	9770 kg (21540 lb)	7297 kg (16087 lb)	10511 kg (23173 lb)
		36.5 m (120 ft)	7731 kg (17044 lb)	11454 kg (25252 lb)	7805 kg (17207)	12109 kg (26696 lb)
RG1100	4164 liter (1100 gal)	<= 30.5 m (100 ft)	7507 kg (16550 lb)	10660 kg (23501 lb)	7747 kg (17078 lb)	11568 kg (25503 lb)
		36.5 m (120 ft)	8004 kg (17645 lb)	11999 kg (26454 lb)	8182 kg (18038 lb)	12863 kg (28359 lb)
RG1300	4921 liter (1300 gal)	<= 30.5 m (100 ft)	7777 kg (17145 lb)	11200 kg (24692 lb)	8198 kg (18073 lb)	12343 kg (27211 lb)
		36.5 m (120 ft)	8350 kg (18409 lb)	12565 kg (27701 lb)	8633 kg (19033 lb)	*13638 kg (*30067 lb)

**NOTE:** Front axle weights are with booms folded, rear axle weights are with booms extended.

Tire pressures for different machine configurations psi/kPa						
Model	Tank size Liters / (Gallons)	Boom length meter / (ft)	Water		28 Percent nitrogen	
			Front	Rear	Front	Rear
RG900	3407 liter (900 gal)	<= 30.5 m (100 ft)	262 kPa (38 psi)	462 kPa (67 psi)	283 kPa (41 psi)	483 kPa (70 psi)
		36.5 m (120 ft)	303 kPa (44 psi)	538 kPa (78 psi)	317 kPa (46 psi)	538 kPa (78 psi)
RG1100	4164 liter (1100 gal)	<= 30.5 m (100 ft)	303 kPa (44 psi)	503 kPa (73 psi)	303 kPa (44 psi)	538 kPa (78 psi)
		36.5 m (120 ft)	338 kPa (49 psi)	538 kPa (78 psi)	338 kPa (49 psi)	538 kPa (78 psi)
RG1300	4921 liter (1300 gal)	<= 30.5 m (100 ft)	317 kPa (46 psi)	538 kPa (78 psi)	338 kPa (49 psi)	538 kPa (78 psi)
		36.5 m (120 ft)	359 kPa (52 psi)	538 kPa (78 psi)	379 kPa (55 psi)	538 kPa (78 psi)

**NOTE:** Pressure recommendations are based on calculated axle weights. The operator is responsible to weigh the machine to determine actual axle weights.  
If axle weight exceeds the axle weight chart, see the maximum tire load chart in this manual.

**Result**

Make sure the wheels are parallel, and this is very important in order to get the correct toe-in measurement.

17. Do the following steps to adjust the toe-in for the rear wheels.
18. Measure the distance from the front center of rim on left side to the front center of the rim on the right side.
19. Measure the distance from the rear center of the left rim to the rear center of the right rim.
20. Set the toe-in on the rear axle at 0.3175 cm (0.125 in) and the toe-out at 0.3175 cm (0.125 in).

**Result**

There is a 0.159 cm (0.0625 in) difference when measuring the distance between the front of the two rear wheels compared to the rear of the two rear wheels.

21. Adjust the toe-in by loosening the steering cylinder jam nut (2) or the nut and bolt.
22. Turn the rod end (1) of the steering cylinder in the correct direction.

**Result**

Lengthening the distance between the ball joint and the cylinder (3) will cause the wheel to toe-in, shortening will cause the wheels to toe-out.

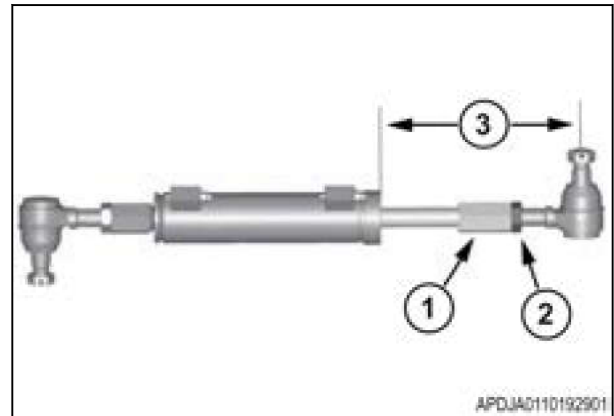

Fig. 108

**Related Links**

[Toe-in values](#) page 226

**4.14.2 Adjust the four wheel steer toe-in**

The illustration is the view from the rear of the front axle (1) and the rear axle (2). The steering cylinders (3) and the track adjust cylinders are shown (4).

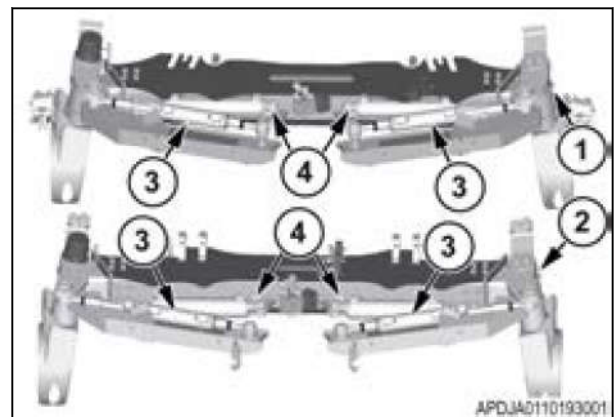

Fig. 109

**Procedure**

1. Park the machine on a solid, level surface.
2. Start the toe-in adjustment by bleeding the air from the track adjust cylinders (4). Start the machine and cycle all four tracking cylinders using the track adjust switches. The keypad is located on the right-hand rear "B" post. Hold the switches for several seconds, after the cylinder has reached full extension and retract. Cylinders must be fully retracted with the wheel legs set to the narrowest position before turning off engine.

## 5 Troubleshooting

<b>5.1</b>	<b>Engine Troubleshooting</b> .....	233
<b>5.2</b>	<b>Heating and cooling troubleshooting</b> .....	236
<b>5.3</b>	<b>Fault code reference</b> .....	238

SA	SPN	SPN Details	FMI
0	626	Grid Heater Relay	5
0	626	Grid Heater Relay	6
0	630	EEPROM Read Write/ Configuration	12
0	639	Controller Area Network Bus Off	19
0	651	Engine Injector Cylinder/ Solenoid valve #1	2
0	651	Engine Injector Cylinder/ Solenoid valve #1	3
0	651	Engine Injector Cylinder/ Solenoid valve #1	5
0	651	Engine Injector Cylinder/ Solenoid valve #1	6
0	651	Engine Injector Cylinder/ Solenoid valve #1	11
0	651	Engine Injector Cylinder/ Solenoid valve #1	14
0	652	Engine Injector Cylinder/ Solenoid valve #2	2
0	652	Engine Injector Cylinder/ Solenoid valve #2	3
0	652	Engine Injector Cylinder/ Solenoid valve #2	5
0	652	Engine Injector Cylinder/ Solenoid valve #2	6
0	652	Engine Injector Cylinder/ Solenoid valve #2	11
0	652	Engine Injector Cylinder/ Solenoid valve #2	14
0	653	Engine Injector Cylinder/ Solenoid valve #3	2
0	653	Engine Injector Cylinder/ Solenoid valve #3	3
0	653	Engine Injector Cylinder/ Solenoid valve #3	5
0	653	Engine Injector Cylinder/ Solenoid valve #3	6
0	653	Engine Injector Cylinder/ Solenoid valve #3	11
0	653	Engine Injector Cylinder/ Solenoid valve #3	14
0	654	Engine Injector Cylinder/ Solenoid valve #4	2

SA	SPN	SPN Details	FMI
0	9682	Diagnostic Fault Check to Report "ABE Active" Due to Over Voltage Detection	31
0	9683	Diagnostic Fault Check to Report "WDA/ABE Active" Due to Unknown Reason	31
0	520200	Powerstage Diagnosis	16
0	520200	Powerstage Diagnosis	18
0	520201	Bus off Engine CAN	19
0	520202	ECU Main Relay 1	3
0	520202	ECU Main Relay 1	4
0	520203	ECU Main Relay 2	3
0	520203	ECU Main Relay 2	4
0	520205	Error in torque control input	31
0	520208	Rail PRV recognized as OPEN	31
0	520209	Error in the plausibility of the injection energizing time	31
0	520210	Error in the plausibility of the start of energizing angles	31
0	520211	ECU Internal fault 0103	31
0	520212	ECU Internal fault 0105	31
0	520213	ECU Internal fault 0106	31
0	520214	ECU Internal fault 0107	31
0	520215	ECU Internal fault 0108	31
0	520216	ECU Internal fault 0109	31
0	520217	ECU Internal fault 0110	31
0	520218	ECU Internal fault 0111	31
0	520219	ECU Internal fault 0112	31
0	520220	ECU Internal fault 0113	31
0	520221	ECU Internal fault 0114	31
0	520222	ECU Internal fault 0115	31
0	520223	ECU Internal fault 0116	31
0	520224	ECU Internal fault 0117	31
0	520225	ECU Internal fault 0118	31
0	520226	ECU Internal fault 0119	31
0	520227	ECU Internal fault 0120	31

SA	SPN	SPN Details	FMI
192	522021	LH Boom Fold Out Driver	6
192	522021	LH Boom Fold Out Driver - Mechanical System Not Responding or Out Of Adjustment	7
192	522022	RH Boom Fold In Driver	5
192	522022	RH Boom Fold In Driver	6
192	522023	RH Boom Fold Out Driver	5
192	522023	RH Boom Fold Out Driver	6
192	522023	RH Boom Fold Out Driver - Mechanical System Not Responding or Out Of Adjustment	7
192	522024	LH Boom Raise Driver	5
192	522024	LH Boom Raise Driver	6
192	522025	LH Boom Lower Driver	5
192	522025	LH Boom Lower Driver	6
192	522026	RH Boom Raise Driver	5
192	522026	RH Boom Raise Driver	6
192	522027	RH Boom Lower Driver	5
192	522027	RH Boom Lower Driver	6
192	522028	LH Tip Fold In Driver	5
192	522028	LH Tip Fold In Driver	6
192	522029	LH Tip Fold Out Driver	5
192	522029	LH Tip Fold Out Driver	6
192	522030	RH Tip Fold In Driver	5
192	522030	RH Tip Fold In Driver	6
192	522031	RH Tip Fold Out Driver	5
192	522031	RH Tip Fold Out Driver	6
192	522032	Boom Hoist Up Driver	5
192	522032	Boom Hoist Up Driver	6
192	522033	Boom Hoist Down Driver	5
192	522033	Boom Hoist Down Driver	6
192	522034	Boom Breakaway Return Driver	5
192	522034	Boom Breakaway Return Driver	6
192	522035	Main Boom Valve Driver	5
192	522035	Main Boom Valve Driver	6

## 6.1 Chassis specifications

Engine	
RG1100B	AGCO power Tier 4F 8.4L turbo charged full electronic control, 311 SAE HP (232 kW) @ 2100 RPM, Peak torque 1500 Nm (1106 lb/ft) @ 1500 RPM, High Idle 2160 RPM, Low Idle 1000 RPM
RG1300B	AGCO power Tier 4F 8.4L turbo charged full electronic control, 339 SAE HP (253 kW) @ 2100 RPM, Peak Torque 1600Nm (1180 lb/ft) @ 1500 RPM, High Idle 2160 RPM, Low Idle 1000 RPM
Hydrostatic Pump	
RG1100B	Tandem Sauer-Danfoss series 90 variable displacement axial piston pumps, 6.1 CIR (100 cc/rev) driven at engine speed, neutral switches on both pump controls.
RG1300B	Tandem Rexroth AA4VG variable displacement axial piston pumps, 7.6 CIR (125 cubic cm/rev), driven at engine speed, neutral switch on pump control.
Hydrostatic Motors	
RG1100B	Sauer-Danfoss H1B bidirectional variable displacement bent axis hydraulic motors. 80 cc/rev (4.88 CID) maximum displacement.
RG1300B	Rexroth A6VE bidirectional variable displacement bent axis hydraulic motors. 107 cc (6.53 CID) maximum displacement.
Suspension	Four-link rear suspension with a pan hard bar. Four-link parallel lower arm front suspension.
Service Brake	Hydrostatic dynamic braking
Secondary Service Brake	Hydraulically operated caliper disc brakes located on both front wheels. Controlled by foot pedal in cab.
Park Brake	Multiple disc hydraulically released, (spring apply, pressure release) located in all four gearboxes controlled by a switch in the cab on the armrest. Visual and audible cab warning (if the machine is out of neutral with the brakes applied no audible alarm).
Steering	Hydrostatic load sense, operated by pressure compensated pump with priority flow control. Non-load reaction, closed center steering unit.

CLICK HERE TO **DOWNLOAD** THE COMPLETE MANUAL

- Thank you very much for reading the preview of the manual.
- You can download the complete manual from: [www.heydownloads.com](http://www.heydownloads.com) by clicking the link below



- Please note: If there is no response to CLICKING the link, please download this PDF first and then click on it.

CLICK HERE TO **DOWNLOAD** THE COMPLETE MANUAL