

Challenger

Operator Manual

8816 / 8824

Planter



CLICK HERE TO **DOWNLOAD** THE COMPLETE MANUAL

- Thank you very much for reading the preview of the manual.
- You can download the complete manual from: www.heydownloads.com by clicking the link below



- Please note: If there is no response to CLICKING the link, please download this PDF first and then click on it.

CLICK HERE TO **DOWNLOAD** THE COMPLETE MANUAL

OPERATION

General Information

FIG. 4: When parking, park the machine and the tractor on a solid level surface. Put all controls in neutral, put the tractor transmission in PARK, and apply the tractor parking brake. Stop the tractor engine and take the key with you.

Make sure the tractor and implement are in the proper operating condition according to the operators manuals. Make sure the tractor brakes and the machine brakes, if equipped, are adjusted correctly.

The tractor must have enough weight and braking capacity, especially when operating on roads and terrain that is not even. Use a tractor of recommended size and weight to tow the machine. See Specifications for the minimum tractor size and weight.

Tractor must be equipped with rollover protective structure (ROPS), and a seat belt. Use seat belt during operation.

Do not dismount from moving machinery.

Always operate the machine with the control console turned on.

Never start the tractor with PTO engaged or control console turned on.

Where possible avoid operating the planter near ditches, embankments and holes. Reduce speed when turning, crossing slopes, and on rough, slippery, or muddy surfaces.

Stay off slopes too steep for operation.

Be aware of the size of the equipment and have enough space available to allow for operation.

Watch for overhead wires or other obstructions when raising markers, and when moving the planter with the marker(s) raised.

Always lower the planter when not in use and relieve the pressure in hoses and cylinders.

Do not stand between the tractor and the implement to install the hitch pin when the tractor engine is running.

FIG. 5: Avoid contact with electrical power lines. Contact with electrical power lines can cause electrical shock, resulting in very serious injury or death.

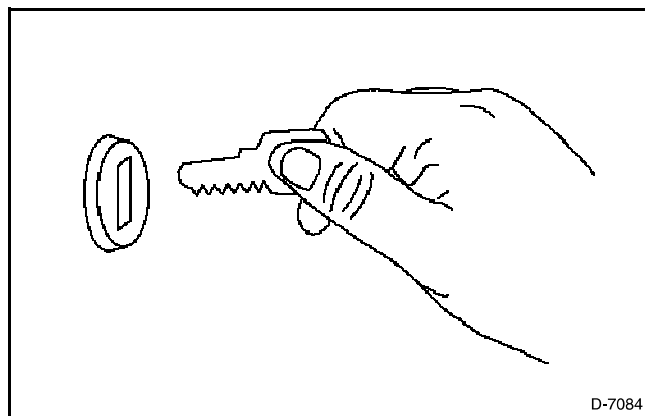

FIG. 4

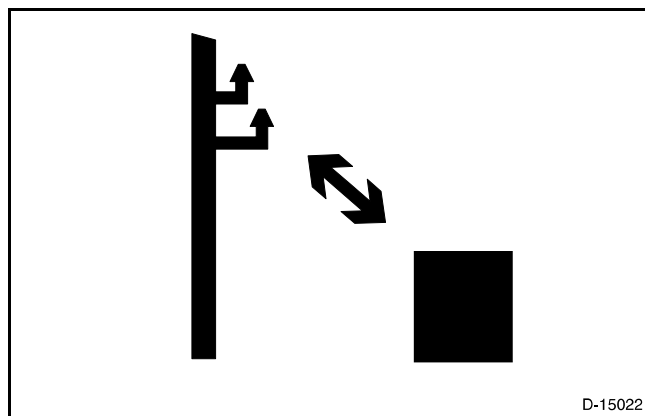

FIG. 5

FIG. 25: Drawbar and two-point hitch (left-hand side)

- (1) Warning sign
- (2) Warning sign
- (3) Warning sign
- (4) Warning sign
- (5) Danger sign

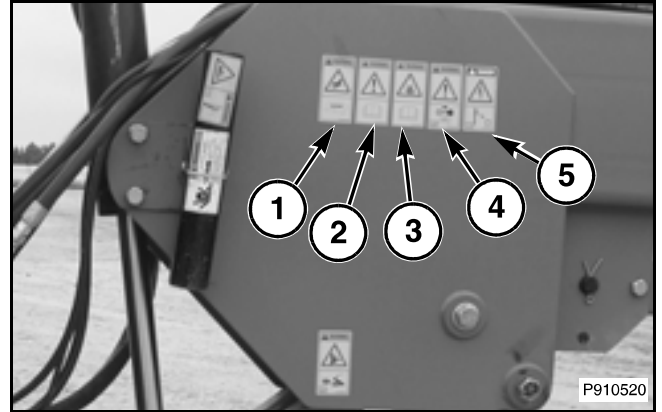

FIG. 25

FIG. 26: Warning sign (1)

Hazard (A) - Escaping fluid under pressure can penetrate the skin and cause serious injury.

Avoidance (B) - See the maintenance manual for proper servicing procedures. Shut off engine, remove key and relieve pressure before performing maintenance or repair work.

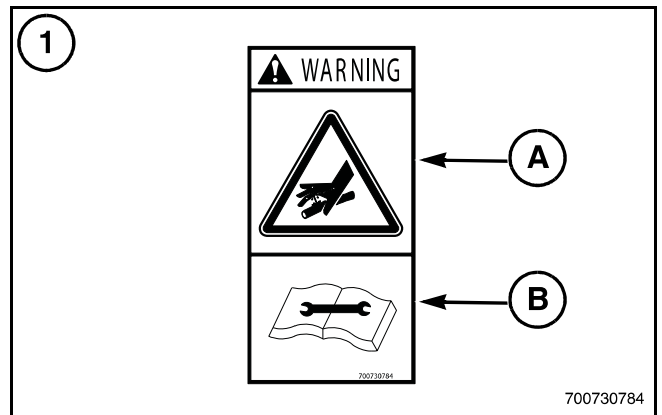

FIG. 26

FIG. 27: Warning sign (2)

Hazard (A) - General safety alert.

Avoidance (B) - Read and understand the Operator's Manual before operating the machine.

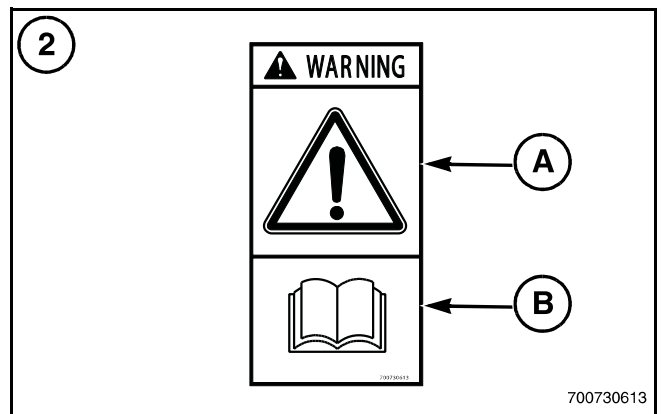

FIG. 27

FIG. 28: Warning sign (3)

Hazard (A) - Chemical injection hazard, lungs - opening the cover.

Avoidance (B) - Refer to the Operator's Manual and the chemical manufacturer's instructions.

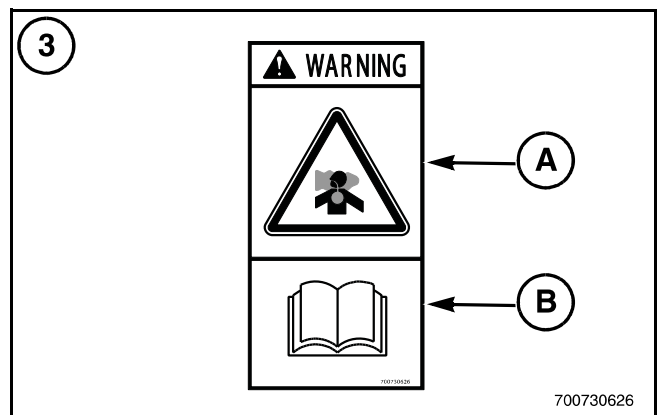

FIG. 28

FIG. 62: Back of Central Fill Platform, Warning sign (1) and SMV emblem (2)

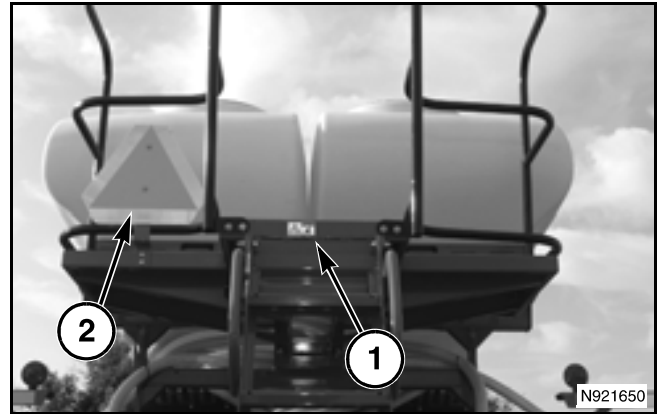

FIG. 62

FIG. 63: Warning sign (1)

Hazard (A) - Falling off hazard.

Avoidance (B) - Do not ride on the machine when it is operating or moving.

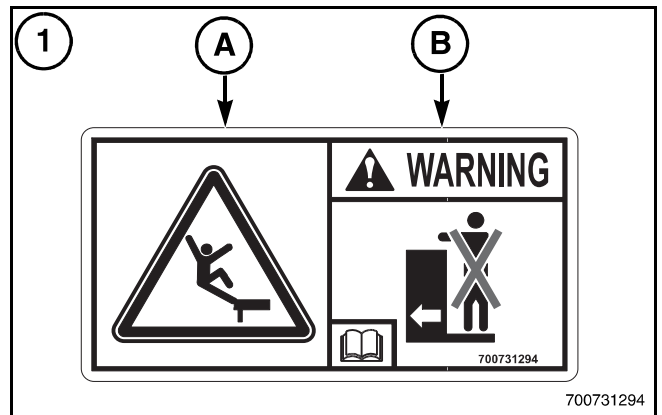

FIG. 63

FIG. 64: Top of the Central Fill Hopper, Warning sign (1)

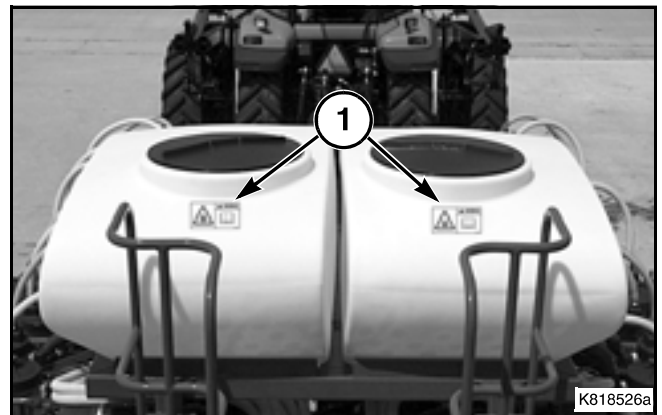

FIG. 64

FIG. 65: Warning sign (1)

Hazard (A) - Chemical injection hazard, lungs - opening the cover.

Avoidance (B) - Refer to the Operator's Manual and the chemical manufacturer's instructions.

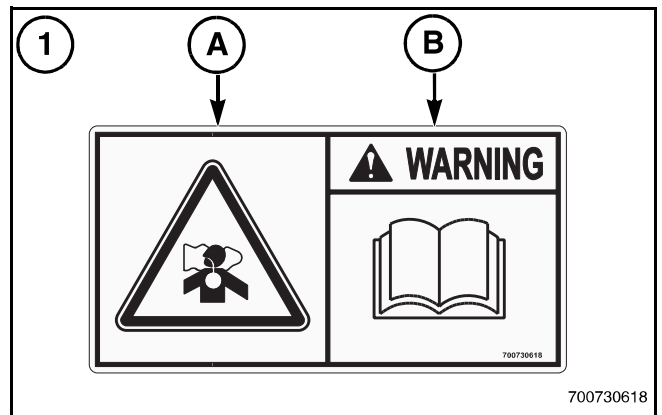

FIG. 65

SERIAL NUMBER DEFINITION (2010 AND UP)

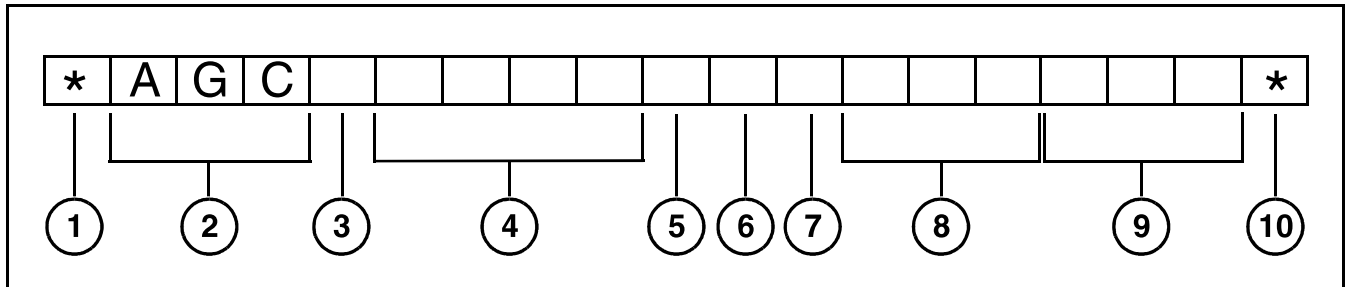

FIG. 4

FIG. 4: Definition of the serial number for model year 2010 and up.

- (1) Beginning symbol
- (2) World Manufacturer Code
- (3) Brand Code
- (4) Model Identifier (Model number)
- (5) Check Letter (0 or used if model identifier is five digits)
- (6) Model Year Code (A=2010, B=2011, C=2012, and on)
- (7) Plant Code
- (8) Family Code
- (9) Unit Number for the Year
- (10) Ending symbol

NOTE: For serial number breaks in this manual, only the information from the model year code and following will be given.

FIG. 7: Frame Lift/Lower Circuit Hoses:

Connect a 5/8 inch ID raise hose (1) to the tractor outlet showing the extended cylinder. Connect a 5/8 inch ID lower hose to the tractor outlet showing the retracted cylinder.

Hitch Height/Marker/Fold Circuit Hoses:

Connect a 3/8 inch ID lower hose (2) to the tractor outlet showing the extended cylinder.

Connect a 3/8 inch ID raise hose to the tractor outlet showing the retracted cylinder.

Connect the frame control box harness to the planter harness.

IMPORTANT: If the planter hydraulic system is not full of fluid, see the Priming Hydraulic Circuits in the Lubrication and Maintenance Section.

IMPORTANT: Before raising, lowering, unfolding or folding the planter, make sure the hoses and the electrical harnesses cannot be pinched and damaged during the operation.

NOTE: See the Frame Control System for complete control box operating.

Connect the ISOBUS planter controller harness to the mating console harness.

IMPORTANT: Connect all the consoles to a 12-volt DC system only.

Connect the highway lighting plug (3) to the tractor receptacle.

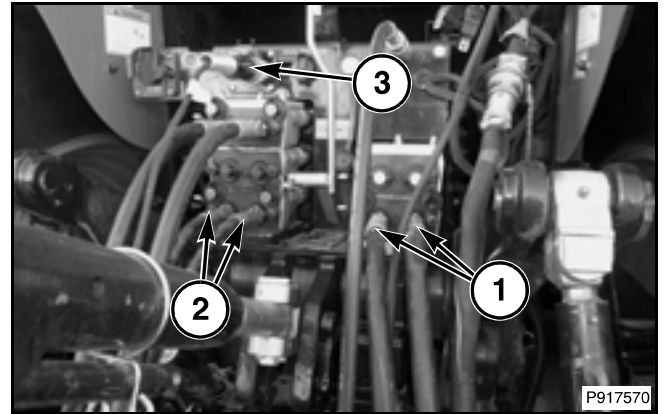

FIG. 7

FIG. 8: Central Fill Blower Hydraulic Connections

(1) Central Fill Blower Circuit Hoses

(2) Case Drain Line - Zero Pressure Return

The hoses are tagged pressure, return, and case drain and are connected to steel tubes on the draft link.

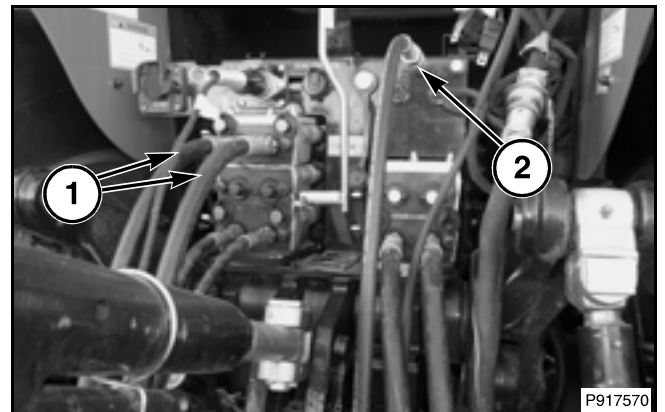

FIG. 8

FIG. 27: The wings are folded and the wing latches are hooked into the wing receiver (1).

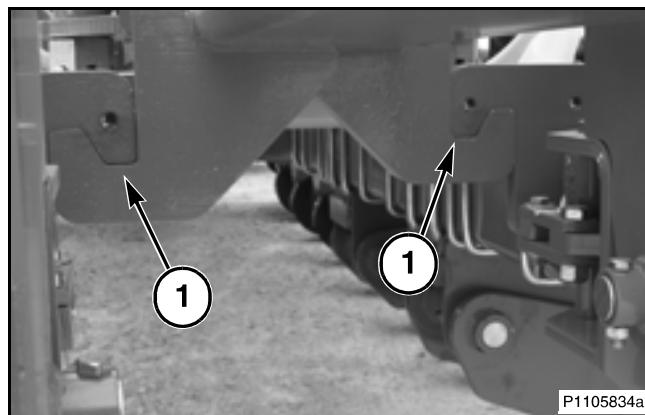

FIG. 27

FIG. 28: If equipped with the wing transport pins (1), install the wing transport pins. Planter is now folded, raised and ready for transport.

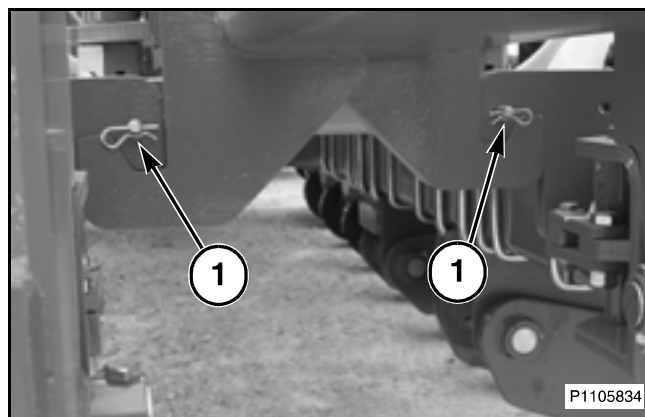

FIG. 28

Unfolding Procedure

FIG. 29: If equipped with the wing transport pins (1), remove the wing transport pins.

Switch the PLANT/OFF/TRANSPORT switch to TRANSPORT and MARKER to OFF. Use the hydraulic valve to fully raise the planter if using three point hitch. If using a drawbar hitch fully raise the planter by holding the TONGUE HEIGHT switch and using the tractor hydraulic valve.

Remove the wheel cylinder lockup channels.

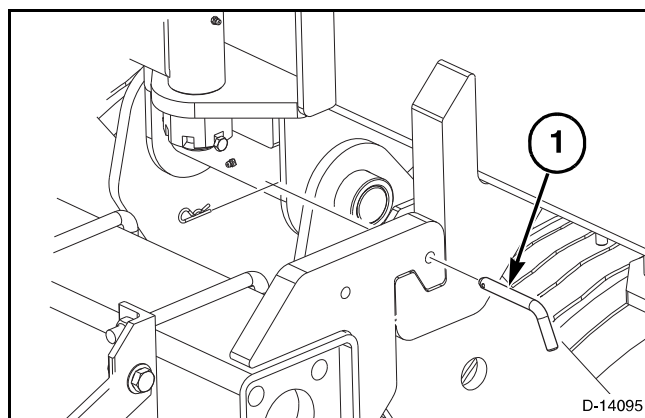

FIG. 29

Chain Guard (Optional)

FIG. 44: Some units are equipped with a chain guard (1).

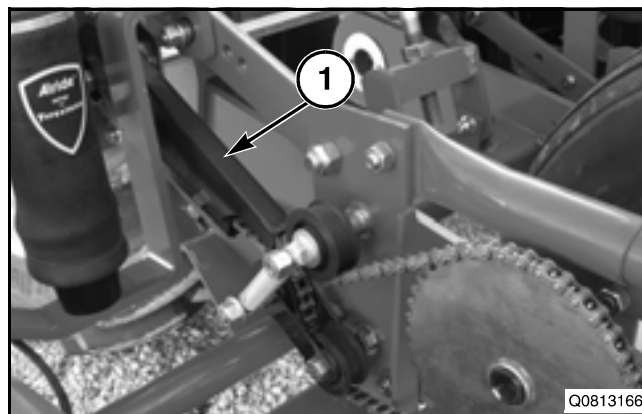

FIG. 44

Seed Meter Covers

FIG. 45: With a central fill system, a molded cover fitted to the seed meter and creates a seed reservoir. To remove the reservoir cover, unscrew the knob bolt (1).

A removable screen (2) under the cover allows pressurized air to escape as the seed is delivered through the seed inlet (3) to the reservoir during operation. When a meter is full, seed covers the reservoir screen, stopping the air/seed flow. Occasionally check the screens and clean as needed.

IMPORTANT: When installing the cover make sure:

- Screen solid area aligns with the seed inlet tube in the cover.
- Inlets are aligned with each other, end to end.

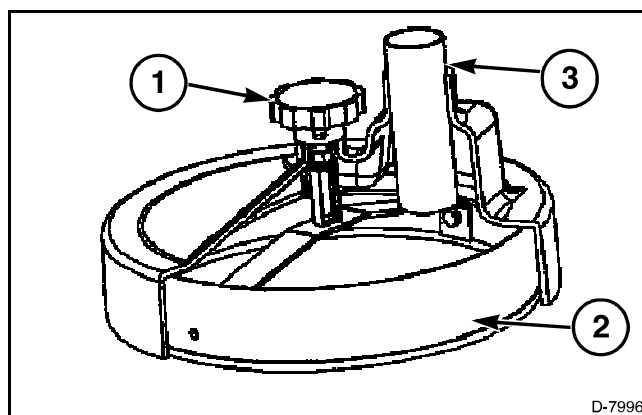

FIG. 45

FIG. 46: Two seed meter screens are available. A screen having 4.8 mm (0.188 in) diameter holes and no solid area is supplied with the vent as standard equipment and can be used with most crops. A screen having 1.9 mm (0.075 in) diameter holes and a solid area is available for crops having small seed sizes.

NOTE: Before installing cover, make sure the solid screen area (1) is oriented closest to the seed inlet.

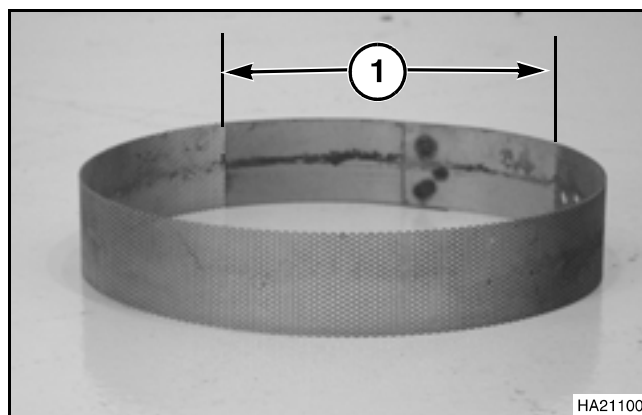

FIG. 46

Residue Manager

NOTE: Heavy-duty or pneumatic down pressure springs are recommended.

FIG. 67: The residue manager is used to push residue off the path of the row unit. Residue wheels must not be used to till the soil.



FIG. 67

Trashmaster

NOTE: Heavy-duty down pressure springs are recommended.

FIG. 68: The trashmaster attachment is used for clearing trash in front of the seed trench.

The trashmaster has two 304 mm (12 in) diameter solid disc blades.

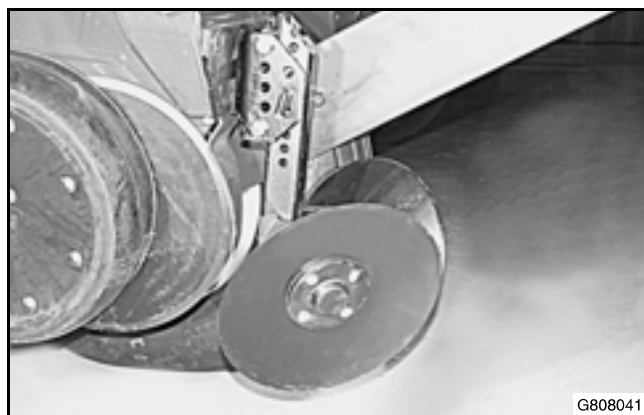

FIG. 68

FRAME-MOUNTED TILLAGE

Tillage Coulter

FIG. 69: The frame-mounted tillage coulter is designed for rough, rocky conditions and for no-till operations. The coulter can be equipped with any of five disc blade types.



FIG. 69

CONSOLE

This planter will operate with ISO 11783 (ISOBUS) tractor systems and consoles.

The console can function as both a seed monitor and a hydraulic drive controller.

A console contains keys, a screen, and an audible alarm for the different functions of the planter.

NOTE: The information and keys will be shown in different locations on different consoles.

It is important you read and understand the Operator Manual that came with your console before reading this section. See the Operator Manual that came with your console for the following information:

- Installing the console in the tractor
- Key or touch screen operation
- Text and Data changing
- Volume
- Display brightness
- Console and implement language and units
- Setting the time and date
- Auxiliary input setup for the master switch
- Ground speed calibration
- Creating as applied maps (If available)
- Variable rate planting using an application map (If available)

OPERATION - HYDRAULIC DRIVE PLANTERS



WARNING: When the planter is operating and the master switch is in the ON position, the planter is fully operational. Failure to follow the necessary safety precautions listed below could result in serious injury or death.

Before Planting

Make sure all settings are correct.

- Correct material is chosen for each active channel. See Material Setup.
- Material settings are correct (seed disc, population). If necessary, set up a new setting. See Material Setup.
- Module configuration is correct. See Module Configuration.
- Ground speed source and calibration is correct. See Ground Speed Setup.
- Seed monitor settings are correct. See Seed Monitor Setup.
- Desired accumulators are set and active. See Data Items and Accumulators screen.
- Each active channel is on.

NOTE: When a channel is on, the  key will be shown. Pressing this key will turn the channel off.

Planting

To start planting:

1. Start the tractor.
2. Make sure meters have seed.
3. Make sure meter air blowers are set correctly.
4. Engage the PTO or tractor hydraulics.
5. Fill the seed discs. See Fill Disc.
6. Lower the planter.
7. Move the master switch to the ON position and begin planting. See Master Switch.

All active control channels will begin controlling at the current ground speed.

All accumulators will begin recording data.

The controller will stop application and most accumulators will stop recording data when one of the following occurs:

- The master switch is moved to the OFF position.
- Ground speed is zero.
- The planter is raised (If equipped with a lift switch).

IMPORT/EXPORT CONFIGURATIONS

The Import/Export Configurations function is only available on consoles that have a file server.

NOTE: AGCO Console I does not have a file server.

This screen permits the operator to import or export planter settings. This information can be used to back up the planter settings or to copy planter settings to another planter.



Press the  key to enter the Import/Export Configuration screen.

FIG. 45: Import/Export Configuration Screen

To import planter settings:

- Insert the SD card with the planter settings into the console card reader.

NOTE: See the console Operator Manual for correct installation and removal instructions. Incorrectly installing the SD card can cause damage to the console and SD card.

- Use the console to enter the name of the Import File.
- Press the  key to import the planter settings.
- Wait for Import Data Success.
- Press the  key to restart the console.
- Remove the card.

To export planter settings:

- Insert a card into the console card reader.
- Use the console to enter the name of the Export File.
- Press the  key to save the planter settings to the card.
- Wait for Export Data Success.
- Remove the card.



FIG. 45

Changing a Material Setting - Ground Drive Planters

If necessary, press the or key to open the Material Selection screen.

Press the or key to open the Material Setup screen.

FIG. 50: Material Setup Screen

NOTE: It is also possible to put a check mark in the material to be changed on the Material Selection screen. Press to open the selected Material Setup screen.

Use the or key to move the next Material Setup screen.

Use the or key to move the previous Material Setup screen.

The number (1) in the upper left-hand corner tells the number of the material setting displayed. There are 16 available material settings.

Change the Type (2) setting from PLANTER CONTROL to Monitor Only.

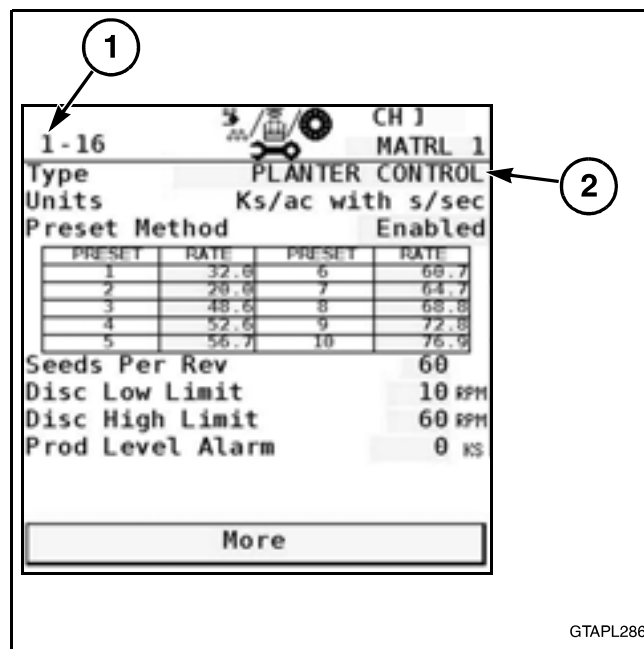

FIG. 50

GTAPL286

Calibrate Parameters

FIG. 60: Calibrate Parameters Screen

The Calibrate Parameters screen gives information.

Press the CALIB
PARAM key on the Channel Setup screen to enter the Calibrate Parameters screen.

Do not change the settings on this screen.

CHANNEL# 2	CAL IB PARAM
System Gain	12.000
Offset	30 %
Max PWM	100 %
Prop Gain (Response)	0.015
Int Gain	0.007
Filter Gain (Boost)	1.0000
PWM Ramp	14.0 %

GTAPL305

FIG. 60

Implement Width (Imp Width)

Implement Width (3) is the seeding width of the implement in inches or centimeters.

The value is used for area accumulators only and does not change seed rate data.

The Implement Width will automatically be calculated if Auto Update is set to Enabled.

If Auto Update is set to Disabled, the width must be entered manually.

Factory Settings		
Model	Implement Width	
	Centimeter	Inch
8816	1219	480
8824	1828	720

On/Off Pattern

On/Off Pattern (4) permits the user to select a row pattern for row units being on or off.

IMPORTANT: This setting is only for monitoring information only. Setting a row to OFF will not stop seed flow.

Each row can be turned off after a pattern setting is set.

When a pattern setting is selected, existing row settings will be changed.

There are 23 patterns available.

Pattern	Description
.....	Every row on
-X-X-X	Every second row off
X-X-X-	Every second row on
--X--X--X	Every third row off
-X--X--X-	Every third row off
X--X--X--	Every third row off
-XX-XX-XX	Every third row on
X-XX-XX-X	Every third row on
-XX-XX-XX	Every third row on
---X---X	Every fourth row off
--X--X-	Every fourth row off
-X---X--	Every fourth row off
X---X---	Every fourth row off
XXX-XXX-	Every fourth row on
XX-XXX-X	Every fourth row on
X-XXX-XX	Every fourth row on
-XXX-XXX	Every fourth row on

Pattern	Description
--XX--XX--XX	Two in a row on/two in a row off
-XX--XX--XX-	Two in a row on/two in a row off
XX--XX--XX--	Two in a row on/two in a row off
X--XX--XX--X	Two in a row on/two in a row off
XX--XX--XX-	Two in a row on/two in a row off
X-XX--XX--X	Two in a row on/two in a row off
Rows turned on = -	
Rows turned off = X	

Population Block Pattern

The Population Blockage Pattern (5) is used to determine which sensors are used to calculate population and which sensors are used only for the detection of blockage.

Set the Block Pattern to Every Row Population.

The following settings are available:

- Every Row Population - All of the rows are used to calculate population. All rows must have Hi Rate sensors.
- Every Row Blockage - All of the rows are used to check for blockage. All rows must have Recon Flow sensors. (Not Available)
- Every 2nd Row Block - Even rows are used for population and odd rows are used to check for blockage.
- Every 2nd Row Pop - Even rows are used to check for blockage and odd rows are used for population.

Row Status

The row status display (6) are shows one of the following icons on each row:



OFF - the row does not detect population or blockage



POPULATION - the row sensor is used to detect population



BLOCKAGE - the row sensor is used to detect blockage

All rows must be set to either OFF or POPULATION.

The row status is set automatically when a block pattern is set. Changing the block pattern will change the manually set row status.

Individual rows can be set. Rows set to off will remain off until set to another setting or when the block pattern is changed.

If the planter has more than 24 rows, press the NEXT ROWS key will be available. Press this key to see rows 25 and up.

Bridge Configuration Factory Settings

8816 Factory Settings			
Row #'s	LEG	MOD	IN
1	DNA	2	A
2	DNA	2	B
3	DNA	2	C
4	DNA	2	D
5	DNA	1	A
6	DNA	1	B
7	DNA	1	C
8	DNA	1	D
9	DNB	3	A
10	DNB	3	B
11	DNB	3	C
12	DNB	3	D
13	DNB	4	A
14	DNB	4	B
15	DNB	4	C
16	DNB	4	D

8824 Factory Settings			
Row #'s	LEG	MOD	IN
1	DNA	3	A
2	DNA	3	B
3	DNA	3	C
4	DNA	3	D
5	DNA	2	A
6	DNA	2	B
7	DNA	2	C
8	DNA	2	D
9	DNA	1	A
10	DNA	1	B
11	DNA	1	C
12	DNA	1	D
13	DNB	4	A
14	DNB	4	B
15	DNB	4	C
16	DNB	4	D
17	DNB	5	A
18	DNB	5	B
19	DNB	5	C
20	DNB	5	D
21	DNB	6	A
22	DNB	6	B
23	DNB	6	C
24	DNB	6	D

Seed/Distance Max Row

FIG. 110: Seed/Distance Max Row displays:

- The seeding row with the maximum number of seeds per distance (1)
- Seeds per distance (meters or feet) (2)

This data item requires a full row on the screen.



FIG. 110

Seed/Distance Average

FIG. 111: Seed/Distance Average displays the average number of seeds per distance (meters or feet) of all active seeding rows.

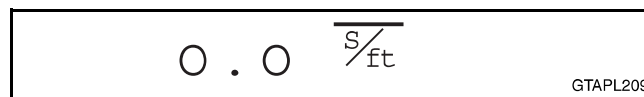

FIG. 111

Singulation Average

FIG. 112: Singulation Average displays the average singulation of all seeding rows set up for population.

Singulation is the percent of single seeds passing the seed sensor instead of groups of seeds.

Singulation requires Seed Smart sensors.

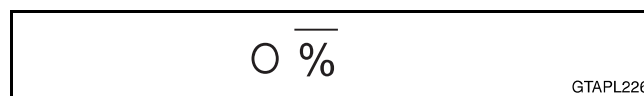

FIG. 112

Singulation Row Scan

FIG. 113: Singulation Row Scan scans all active seed rows and displays:

- Current row number being scanned (1)
- Singulation for the scanned row (2)

Singulation requires Seed Smart sensors.

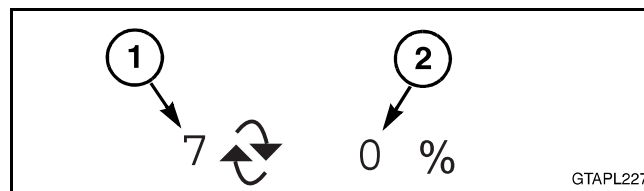

FIG. 113

Singulation Min/Max Scan

FIG. 114: Singulation Min/Max Row Scan alternately displays:

- The seed row with the minimum singulation and the seeding row with the maximum singulation (1)

The display changes every four seconds from minimum to maximum.

- Singulation (2)

Singulation requires Seed Smart sensors.

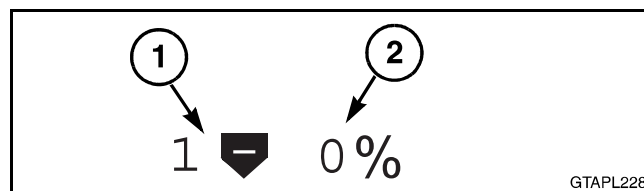

FIG. 114

Ground Speed (Factory Default)

FIG. 115: Ground Speed displays the current ground speed of the tractor in kilometers per hour or miles per hour.

The ground speed source set in the Ground Speed Setup screen. See Ground Speed Setup in this section.

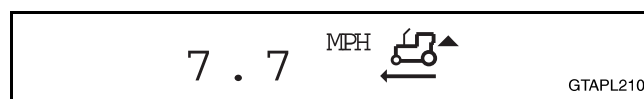

FIG. 115

TESTS

These tests are for hydraulic drive planters only.

FIG. 137: Five Revolution Test Screen

Fill Disc, the Continuous Test, and the Five Revolution Test will only operate the current channel. To run a test on the other channel, it will be necessary to press the $\left[\text{X} \right] + 1$ key to change the current channel. The current channel will be displayed at the top right-hand of each screen (1).

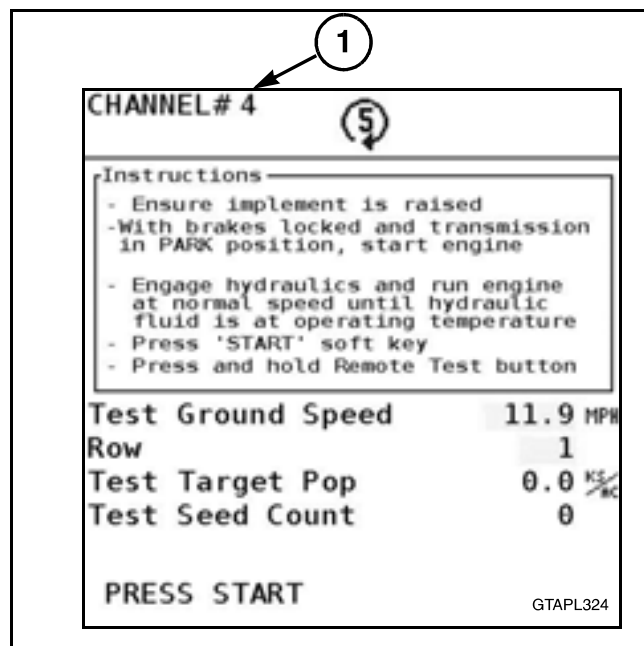

FIG. 137

Remote Test Switch



WARNING: When the remote test switch is pressed, the planter can become operational. Failure to follow the necessary safety precautions listed below could result in serious injury or death.

FIG. 138: The remote test switch permits the user to turn the control on or off during the Continuous and Five Revolution Test in this section.

The remote test switch and long lead wire are stored in a row unit mounted tube.

To use, connect the remote test switch to the wiring harness on the planter. Press the button to operate the planter. Release the button to stop the planter operation.

If the planter is raised to run the test, and the planter is equipped with an implement lift switch, the Implement Lift setting needs to be set at Disabled.

Planters with HS serial number and software before version 2.70 - If the planter is not equipped with an implement lift switch, the two wires for the implement lift switch are connected together. The wires for the implement lift switch must be disconnected before using the remote test switch. Connect the wires before operating the planter in the field.

Planters without an implement lift switch and with software version 2.70 and up - Make sure the Implement Lift setting is set to Disabled.



FIG. 138

CLICK HERE TO **DOWNLOAD** THE COMPLETE MANUAL

- Thank you very much for reading the preview of the manual.
- You can download the complete manual from: www.heydownloads.com by clicking the link below



- Please note: If there is no response to CLICKING the link, please download this PDF first and then click on it.

CLICK HERE TO **DOWNLOAD** THE COMPLETE MANUAL

ISOBUS Planter Electronics

Alarm Number	Description	Possible Cause	Correction
225	HOPPER SENSOR LOW ALARM	Wrong Logic Level setting on the Hopper Setup screen Dirty or bad hopper sensor Bad module harness or module	Check the Logic Level setting on the Hopper Setup screen. Clean and inspect the hopper sensor. Replace if necessary. Check the module and module harness for damage. Replace if necessary.
226	RPM SENSOR HIGH LIMIT EXCEEDED ALARM The sensed speed is higher than the High Alarm setting on the RPM setup screen	Planter malfunction or wrong setup Bad sensor Bad module	Check for the proper operation of the planter. Check the High Alarm setting on the RPM Setup screen. Check the sensor for damage. Replace if necessary. Inspect the module for damage. Replace if necessary.
227	RPM SENSOR LOW LIMIT EXCEEDED ALARM The sensed speed is lower than the Low Alarm setting on the RPM setup screen	Planter malfunction or wrong setup Bad sensor Bad module harness or module	Check for the proper operation of the planter. Check the Low Alarm setting on the RPM Setup screen. Check the sensor for damage. Replace if necessary. Check the module and module harness for damage. Replace if necessary.
228	HOPPER SENSOR DETECTION ALARM The number of hopper sensors connected is not the same as the number of sensors configured on the Hopper Sensor Configuration screen	Bad hopper sensor Bad module or damaged module harness Additional hopper sensors detected	Check the hopper sensor for damage. Replace if necessary. Check the module and module harness for damage. Replace if necessary. Make sure the number of hopper sensors is correct in the # HOPP setting for each module.
229	HOPPER SENSORS INSTALLED INCORRECTLY ALARM Hopper sensors are not installed in a sequence on a module	Wrong hopper sensor connections Bad hopper sensor Bad module or damaged module harness	Make sure the hopper sensors are connected in a sequence on all modules. Check the hopper sensor for damage. Replace if necessary. Check the module and module harness for damage. Replace if necessary.
230	PRESSURE SENSORS INSTALLED INCORRECTLY ALARM Pressure sensors are not installed in a sequence on a module	Wrong pressure sensor connections Bad pressure sensor Bad module or damaged module harness	Make sure the pressure sensors are connected in a sequence on all modules. Check the pressure sensor for damage. Replace if necessary. Check the module and module harness for damage. Replace if necessary.
232	RPM SENSOR LOW LIMIT EXCEEDED WITH CONTROL CHANNEL SHUTDOWN ALARM Speed has dropped below the Disable Control on Low Alarm setting on the Accessories Setup screen	Bad RPM sensor Damaged module harness Bad module	Check the RPM sensor for damage. Replace if necessary. Check the module harness for damage. Replace if necessary. Check the module for damage. Replace if necessary.

Tickler Brush

FIG. 8: For some seeds, remove the tickler brush or remove the screw and pivot brush downward, away from disc cells.

To adjust the tickler brush:

- Remove the screws (1) from the tickler brush (2).
- Adjust the tickler brush down away from the seed disc cells.

NOTE: Do not install the screw(s) in the housing without the tickler brush. The threaded screw ends protrude into the seed throat and will interfere with the seed flow.

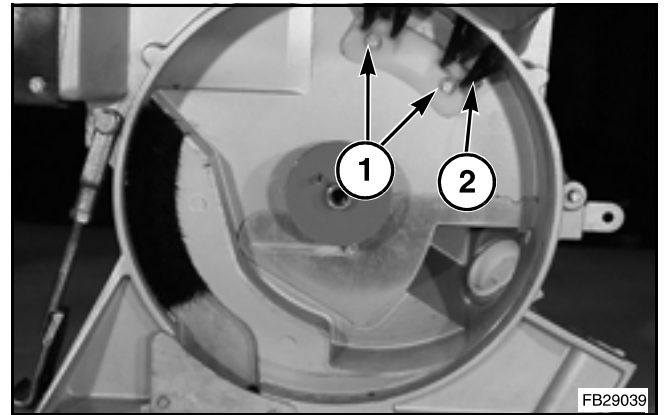

FIG. 8

FIG. 9: There is a short tickler brush available from your dealer to be used with the sunflower disc.

The shorter tickler brush has an identification mark (1).

The standard tickler brush length is 1.25 inch (2). The shorter tickler brush length is 1.083 inch (3).

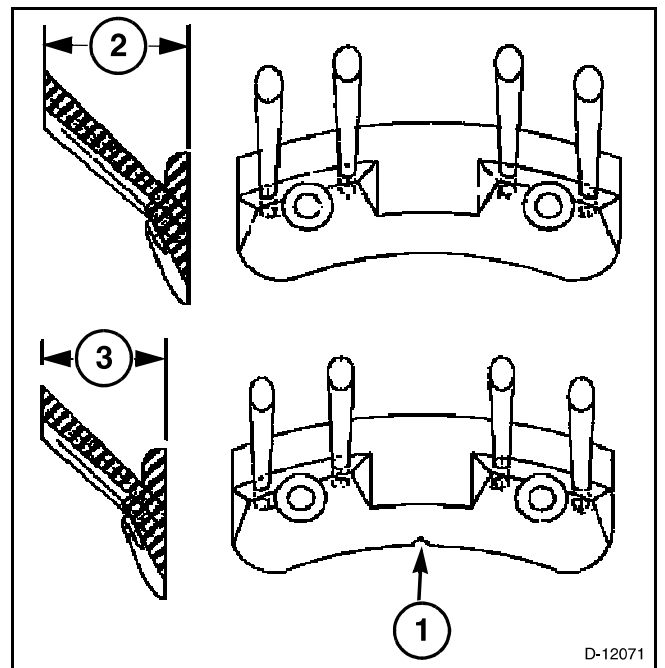

FIG. 9

FIG. 10: Seed Meter reservoir Screen

To remove the reservoir cover, unscrew the knob.

Two screens are available. A screen having 4.8 mm (0.188 in) diameter holes and no solid area is supplied as standard equipment and can be used with most crops.

A screen having 1.9 mm (0.075 in) diameter holes and a solid area (1) is available for crops having small seed sizes.

NOTE: Before installing cover, make sure solid screen area is oriented closest to seed inlet.

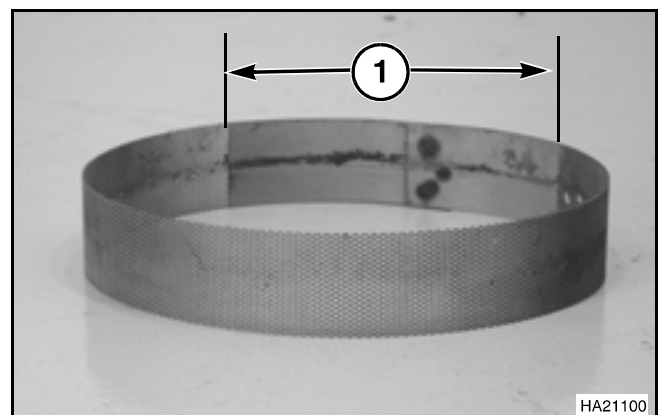

FIG. 10

50 Seeds per Disc (Continued)

Max MPH at listed rate and spacing	Sprocket Clusters in the Seed Rate Transmission			Seed Disc 852441 - Edible Bean								Avg. Seed Spacing (inches)
	A	B	C	15 inch	18 inch	19 inch	20 inch	30 inch	36 inch	38 inch	40 inch	
8.0	48	27	38	68950	55568	52892	50212	33475	27784	26446	25106	6.24
8.0	48	26	38	64462	53503	50924	48346	32231	26751	25462	24173	6.48
8.0	48	25	38	61993	51453	48974	46494	30996	25726	24487	23247	6.78
8.0	48	28	44	59963	49768	47371	44971	29981	24884	23685	22485	6.96
8.0	48	27	44	57822	47992	45677	43366	28911	23996	22838	21683	7.26
8.0	48	26	44	55681	46214	43987	41760	27840	23107	21993	20880	7.50
8.0	48	25	44	53540	44438	42294	40155	26770	22219	21147	20077	7.80

FIG. 13: List of sprocket clusters:

- (1) Sprocket Cluster A
- (2) Sprocket Cluster B
- (3) Sprocket Cluster C

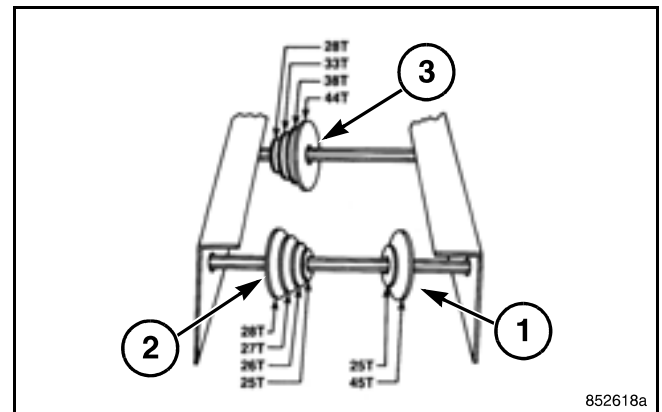

FIG. 13

NOTE: This can vary due to tillage practices, soil types, tire air pressure, ground speed, and planter size which affect the distance traveled per revolution of the planter drive tires. Transmission settings can require adjustments to compensate for individual planter characteristics.

Consult seed supplied for population and seed spacing recommendations.

To prevent miscalculations, make field checks to be certain of planting at the desired rate. Check actual seeds planted over a measured distance to determine actual spacing and population. The operator is responsible for making sure the desired population is planted.

Closing Wheel Spacing and Offset

Dual Wheels

NOTE: Three spacers are installed on the attaching bolt of each wheel. During normal operating conditions, two spacers are inside the wheel. One spacer is on the outside of the wheel.

FIG. 24: To change the spacing:

- Remove the wheel bolt (1).
- Move the spacers (2) inside or outside to hold the correct pressure.

The spacing adjustment range is 32 to 73 mm (1-1/4 to 2-7/8 in) measured to the centerline of the wheels.

NOTE: Various soil conditions and planting depths can require adjustment to the closing wheel spacing for the best performance.

To offset the wheels for rocky or cloddy soil conditions, remove either wheel and install in the alternate mounting hole.

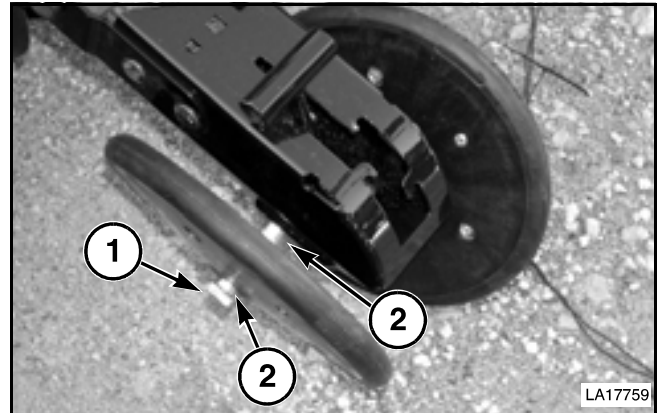

FIG. 24

Piston Pump Rate Chart - Double Chain

FIG. 45: Double chain pump drive. Arrow is pointing in the forward direction.

Piston Pump Application Rates Gallons Per Acre		
Number of Rows	16	24
Row Spacing	30	30
Pump Setting		
2.0	6.6	4.4
2.5	8.2	5.5
3.0	9.9	6.6
3.5	11.5	7.7
4.0	13.1	8.8
4.5	14.8	9.8
5.0	16.4	10.9
5.5	18.1	12.0
6.0	19.7	13.1
6.5	21.3	14.2
7.0	23.0	15.3
7.5	24.6	16.4
8.0	26.3	17.5
8.5	27.9	18.6
9.0	29.6	19.7
9.5	31.2	20.8
10.0	32.8	21.9

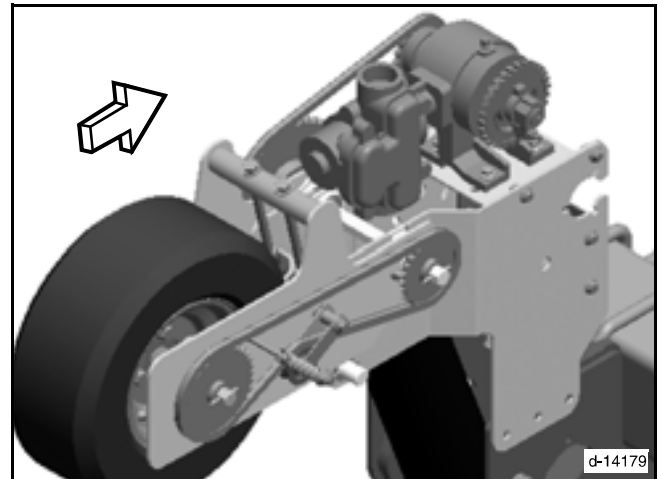

FIG. 45

Use the chart above to determine piston pump setting for the desired rate.

Example:

- Desired rate, per acre = 30 gallons
- Row spacing = 30 inch
- Planter = 16

Read across the top rows to 16 and 30, then down to 29.6 (gpa). Pump setting is in the left column. Set the pump at 9.0 to apply approximately 30 gpa.

Insecticide In-Furrow Placement

FIG. 60: Insecticide can be placed directly in the seed trench with the L-bracket and clamp (1) for dual closing wheels.

The bracket and hardware are included with the chemical attachment bundle. A similar arrangement also provides in-furrow placement with a single closing wheel.

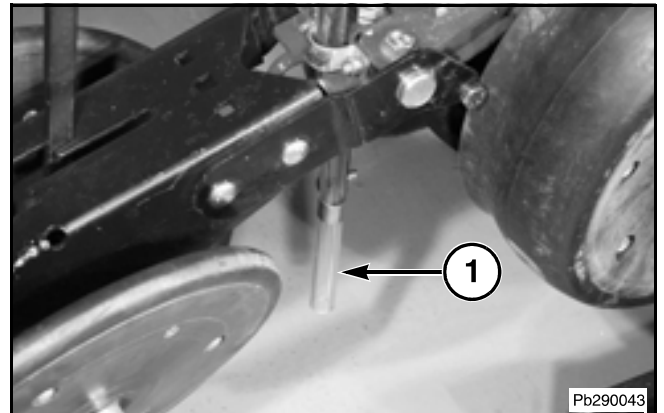

FIG. 60

Spring Tooth Incorporator

FIG. 61: The spring tooth incorporator mixes herbicide and/or insecticide into the soil and smoothes the soil behind it.

Spring tooth down pressure is adjusted by increasing tension on the cable frame side members.

To adjust the spring tooth:

- Loosen the bolts (1), on the cable frame (2).
- Push down on center of cables while tightening bolts.
- Adjust the tine (3) angle by loosening bolts (4) on rear cable frame.

NOTE: Support the chains. The chains are loose during normal operation.

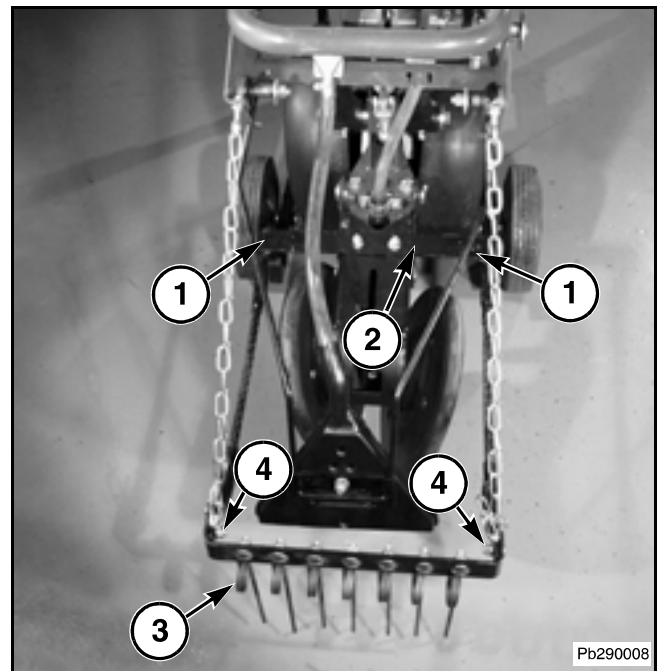

FIG. 61

LUBRICATION AND MAINTENANCE

Contents

General Maintenance	F-3
Beginning of Day	F-3
End of Day	F-3
Beginning of Season	F-3
End of Season	F-3
Lubrication Chart	F-4
Lubrication	F-5
Lubrication Points	F-5
Frame	F-6
Two Point Hitch	F-7
Drawbar Hitch	F-9
Wheel Pivots	F-9
Markers	F-10
Fertilizer Pump	F-12
Wheel Bearing Maintenance	F-14
Adjustment	F-14
Hydraulic Fluid	F-15
Hydraulic Fluid Filter	F-15
Seed Meters	F-16
Removal	F-16
Installation	F-16
J-Bolt Adjustment	F-16
Clutch Alignment	F-17
Drive Shaft and Bearing Removal	F-17
Drive Shaft and Bearing Installation	F-17
Seed Disc Clearance	F-18
Brush Maintenance	F-18
Gauge Wheels	F-20
Tire-to-Opener Clearance	F-20
Wheel Arm Endplay	F-20
Depth Calibration	F-20
Opener Rotary Scraper	F-21
Bearings	F-21
Tension	F-21
Disc Bearing Replacement	F-21
Seed Tubes	F-22
Tube Guard	F-22
Tube Clip	F-22
Seed Transmission for Ground Drive	F-23
Sprocket Cluster Assembly	F-23
Seed Transmission Drives, Idlers, and Chain Routing	F-23
Torsion Spring	F-25
Shear Bolt	F-26
Wing Drive Shaft Couplers	F-26
Piston-type Liquid Fertilizer Pump	F-27
Cleaning the Pumping System	F-27
One to Two Week Storage	F-27
Overnight Storage	F-27
Winter Storage	F-27
Strainer Screen	F-28
Component Service	F-28
ISOBUS Planter Controller	F-28
Master Switch	F-28
Test Button	F-29
Speed Sensor and Motor	F-29
Hydraulic PWM Valve	F-30
Control Solenoid	F-30
Frame Hydraulic System	F-31
Hydraulic Hookup	F-31

LUBRICATION AND MAINTENANCE

FIG. 20: Marker Disc Hubs

(1) Tapered Bearing

Check annually and replace as needed.

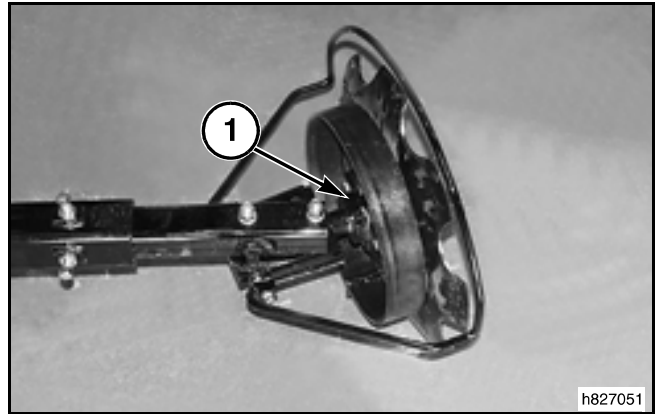

FIG. 20

FIG. 21: Marker wheel hub (each side).

(1) Bearing

Lubricate annually and replace as needed.

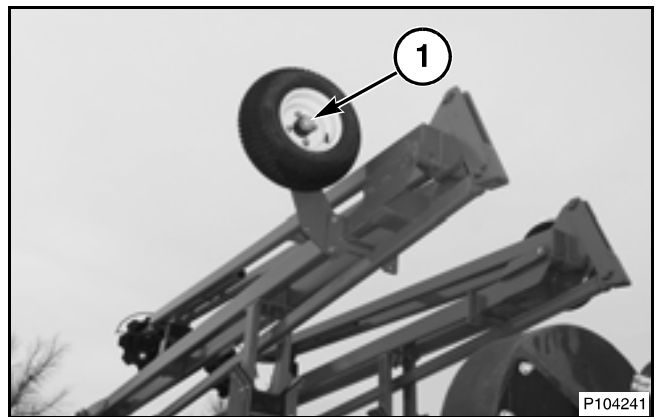

FIG. 21

OPENER ROTARY SCRAPER

Bearings

FIG. 43: Remove the scraper support arm to inspect the bearing (1) and bearing retainer (2). Replace as needed.

To remove the bearing, pry off the retainer through the clip pin hole. Install a new bearing. Snap the retainer in place. Install the clip pin (3).

When installing a scraper support arm on a row unit, adjust the arm position so the scraper (4) edges (5) are flush with the edges (5) of the opener discs (6).

Check and adjust the scraper tension.

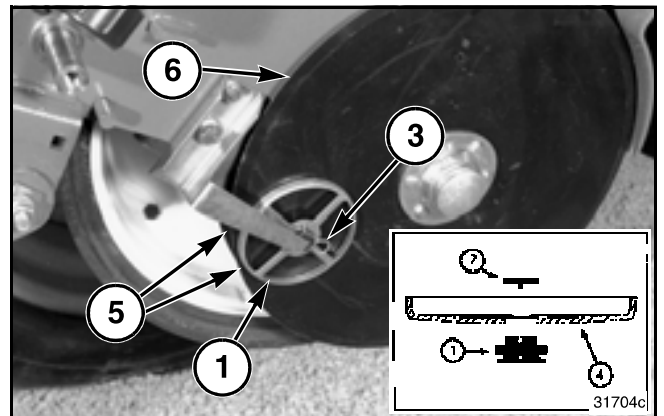

FIG. 43

Tension

FIG. 44: To measure the scraper tension follow these steps:

The force required to deflect the scraper arm away from the disc is 4.5 kg (10 lb). To check, fasten a spring scale to the scraper arm and pull. To adjust, bend the scraper arm in or out until required force is attained.

NOTE: Make sure entire circumference of scraper contacts the opener disc.



FIG. 44

Disc Bearing Replacement

To check opener bearing condition, remove gauge wheels and scrapers. Rotate opener discs to check for bearing roughness and wear. If replacement is required, remove each disc by removing hubcap and cap screw.

NOTE: Cap screw on Left-hand side has Left-hand thread.

Replace bearings and install opener discs on frame. Check disc contact (below) and add shims as required. Tighten cap screw to 183 Nm (135 ft lb).

Blade Replacement

Replace disc blades if worn to less than 36 cm (14 in) diameter.

FIG. 45: As discs wear, keep openers adjusted so discs contact each other at outer edges for a dimension (A) of 25 mm (1 in) as shown. To adjust, remove shim(s) between discs and row unit frame. Store extra shims under cap screw heads.

NOTE: Whenever opener discs are adjusted, adjust scrapers.

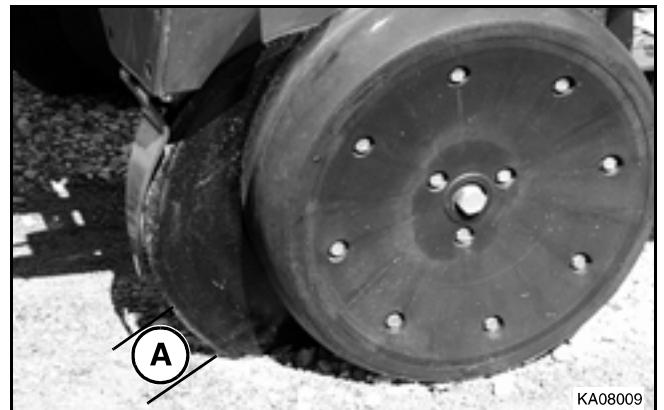

FIG. 45

FRAME HYDRAULIC SYSTEM

Hydraulic Hookup

With tractor engine off, relieve internal system hydraulic pressure, then connect planter hydraulic hoses to the tractor remote outlets.

- Frame Lift/Lower Circuit Hoses (5/8 inch dia.): Connect RAISE hose to the tractor outlet showing extended cylinder. Connect LOWER hose to tractor outlet showing retracted cylinder.
- Hitch Height/Marker/Fold Circuit Hoses (3/8 inch dia.): Connect LOWER hose to tractor outlet showing extended cylinder. Connect RAISE hose to tractor outlet showing retracted cylinder.

Install control box in cab. Connect frame control box harnesses to planter harnesses.

Priming the Hydraulic Circuits

Planter comes with oil and hydraulic circuits primed.

To prime the lift system lower the planter. Hold the lever to allow the oil to bypass from the slave cylinder to the master cylinder and then to the tank.

IMPORTANT: Before purging air from (priming) the hydraulic circuits, select an area with a hard, level surface large enough to allow wings and markers to fully extend. Also, have room ahead of and behind the tractor.

IMPORTANT: Planter hydraulic system requires approximately 11 gallons of fluid. Make sure to check tractor fluid supply often when priming circuits and add as required.

IMPORTANT: To avoid potential damage to the wings when folding, the tractor must be in neutral and the brakes unlocked for the folding/unfolding procedure. The tractor will move forward and backward.



WARNING: Be sure everyone is clear of planter before proceeding to fold or unfold planter and when raising or lowering markers.

FIG. 82: Marker/Fold/Tongue Circuits

- (1) Left Marker Cylinder
- (2) Marker/Fold/Hitch Valve
- (3) Left-Hand Frame Fold Cylinder
- (4) Latch Cylinder
- (5) Right-Hand Frame Fold Cylinder
- (6) Marker Sequence Valve
- (7) Right Marker Cylinder

LUBRICATION AND MAINTENANCE

Connect the bridge DNA (A) to the harness and plug into the left-hand interface module (3) to the UP.

(3) Connect the Interface module 3 to:

- SA to Row 9
- SB to Row 10
- SC to Row 11
- SD to Row 12

Connect the interface module (3) harness DOWN (DN) to the Interface module (2) UP.

(2) Connect the Interface module 2 to:

- SA to Row 5
- SB to Row 6
- SC to Row 7
- SD to Row 8

Connect the interface module (2) harness DOWN (DN) to the Interface module (1) UP.

(1) Connect the Interface module 1 to:

- SA to Row 1
- SB to Row 2
- SC to Row 3
- SD to Row 4

Interface module 1 DOWN (DN) is plugged.

Connect the bridge DNB (B) to the harness and plug into the right-hand interface module (4) UP.

(4) Connect the Interface module 4 to:

- SA to Row 13
- SB to Row 14
- SC to Row 15
- SD to Row 16

Connect the interface module (4) DOWN (DN) to the Interface module (5) UP.

(5) Connect the Interface module 5 to:

- SA to Row 17
- SB to Row 18
- SC to Row 19
- SD to Row 20

Connect the interface module (5) DOWN (DN) to the Interface module (6) UP.

(6) Connect the Interface module 6 to:

- SA to Row 21
- SB to Row 22
- SC to Row 23
- SD to Row 24

Interface module (6) DOWN (DN) is plugged.

INTERFACE MODULE

FIG. 94: Interface Module

- (1) Indicator Lamp
- (2) UP Indicator Lamp
- (3) DN Indicator Lamp

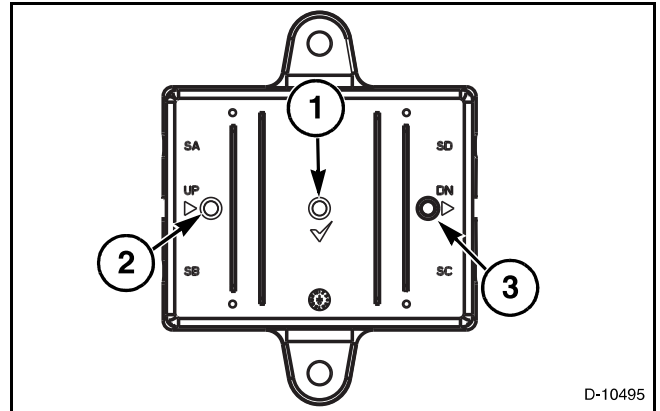

FIG. 94

TABLE 1

Interface Module Diagnostic Indicator Lamp Operation			
Indicator Lamp	Flash Sequence	Description	Notes
On power up, all indicator lamps illuminate for approximately 2 seconds.			
✓ Indicator Lamp	Flash repeatedly 0.5 seconds on and 0.5 seconds off. Flash approximately 16 times in succession (0.125 seconds for each flash) while the sensor detection process is running. Flash 3 times in succession (0.125 seconds for each flash), then pause for 1 second. Flash 2 times in succession (0.125 seconds for each flash), then pause for 1 second.	Interface Module is operating properly. After initial system power up. Interface Module supply voltage below 8.6 VDC or above 16.0 VDC. Interface Module sensor supply voltage below 4.0 VDC or above 9.0 VDC.	The Check indicator lamp will then begin flashing as described. The pattern repeats until the condition is corrected. The pattern repeats until the condition is corrected.
UP Indicator Lamp	Flash for 0.125 seconds. Illuminate continuously.	Whenever communications are received from the module (Bridge or Interface) connected ahead of it. Interface Module detects a communication failure on UP circuit.	Failure needs corrected. The corresponding UP or DN indicator lamp on the next module connected will also be illuminated continuously.

PLANTER TROUBLESHOOTING

PLANTER TROUBLESHOOTING		
PROBLEM	POSSIBLE CAUSE	REMEDY
Openers plugging	Planter not level	Level planter
	Soil too wet	Let soil dry
	Planter lowered without moving	Move forward as planter is lowered
	Planter rolling backward	Do not back up with planter in ground
	Openers worn out	Replace openers
Uneven planting Depth	Row units not set the same. Shallow depth in tire tracks	Set units deeper following tire tracks
	Not enough down pressure	Increase down pressure spring tension
	Too much down pressure	Decrease down pressure spring tension
	Varying soil consistency	Plant for average conditions
	Incorrect closing wheel adjustment	Adjust wheels correctly
	Planter not operating on level	Adjust hitch so planter is level
No seed planted	ISOBUS planter controller not operating properly	Switch ISOBUS planter controller on or troubleshoot and correct
	ISOBUS planter controller programmed incorrectly	Program ISOBUS planter controller
	PTO not operating	Engage PTO
	Pump not installed properly	Install pump correctly
	Row unit seed tubes plugged	Unplug tubes
	Hoppers empty	Fill hoppers
	Shear pin(s) missing	Install pin(s)
	Seed meter blower(s) not operating	Troubleshoot and correct.
	Incorrect air pressure	Adjust air pressure
	Control channels 1 and 2 not ON	Turn ON control channels 1 and 2
Seed spacing incorrect	ISOBUS planter controller not operating properly	Troubleshoot and correct
	ISOBUS planter controller programmed incorrectly	Program ISOBUS planter controller
	Metering unit brushes worn	Replace brushes
	Incorrect manifold air pressure	Adjust air pressure
	Incorrect seed disc	Install correct disc
	Irregular seed size	Use properly-sized seed
	Ground speed too fast	Reduce speed

ACCESSORIES AND OPTIONS

Contents

Console Kits	J-3
Seed Sensor Kits	J-4
Row Unit Drive Chain Guard Kit	J-4
Stroke Control Segments Kit	J-4
Hoppers and Kits	J-5
Closing Wheels Kit	J-6
Row Unit Linkage-mounted Attachments Kit	J-7
Row Unit Mounted Tillage Kits	J-8
Coulter Discs Kits	J-10
Blade Types	J-10
Liquid Fertilizer Kit	J-11
Dry Chemical Kit	J-12
Fertilizer Openers Kit	J-12
Double-Disc Openers	J-12
Single-Disc Openers	J-13
Point Row Clutch Kit	J-13
Tow Hitch Kit	J-13
Flat Scraper Kits	J-14
Drive Wheel Mud Scraper Kit	J-14
Down Pressure Springs Kits	J-15
Inlet Blower Screen Kit	J-16
Central Fill System Screen Kit	J-16
Safety and Instructional Sign Replacements	J-16
Service Manual	J-16

ACCESSORIES AND OPTIONS

FIG. 25: The bubble blade (1) is used in compacted soils with high residue.

The bubble blade wedges soils apart to provide a V seedtrack and operates well at most speeds.

The seed trench profile of the bubble blade is less than 19 mm (3/4 in) in the bottom to 32 mm (1-1/4 in) on the top.

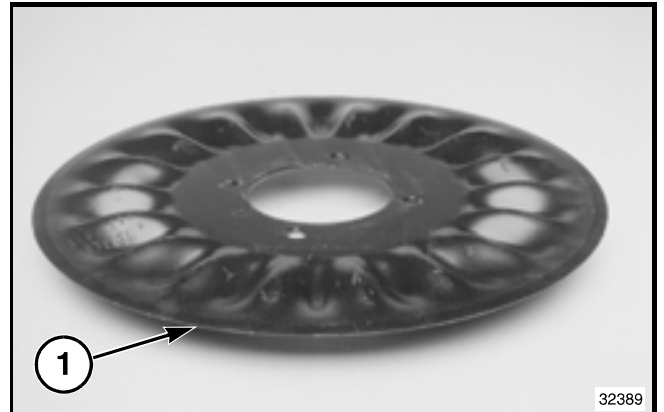

FIG. 25

FIG. 26: The eight fluted blade (1) is used in soft soil conditions and mixes soil with surface residue.

The eight fluted blade operates well at higher speeds.

The eight fluted blade provides a seed trench width of 22 to 38 mm (7/8 to 1-1/2 in).

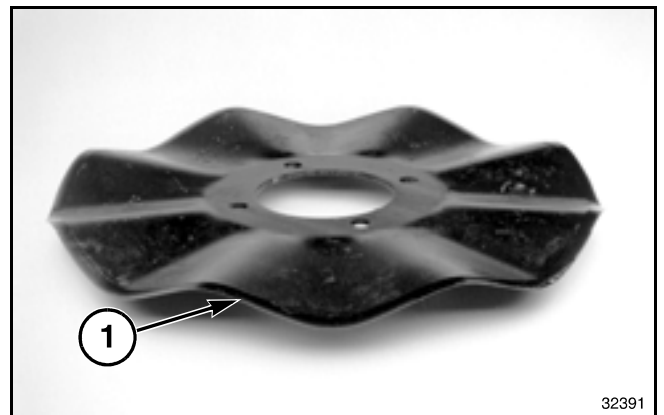

FIG. 26

FIG. 27: The thirteen fluted blade (1) provides aggressive soil and residue mixing. The thirteen fluted blade cuts through residue and is ideal for medium soils. The thirteen fluted blade operates well at most speeds.

The thirteen fluted blade provides a seed trench width of 7/8" to 1-1/4: (22 to 32 mm).

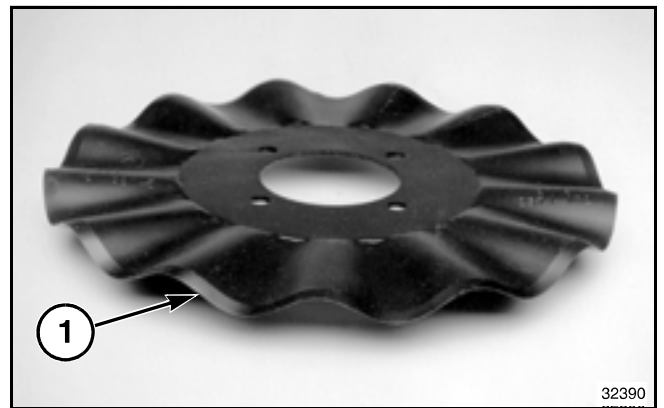

FIG. 27

FIG. 28: The 25 fluted blade (1) is used in no-till and minimum till conditions, with heavy residue.

The 25 fluted blade is less aggressive than the thirteen fluted blade. The 25 fluted blade operates well at most speeds.

The 25 fluted blade provides a seed trench width of 22 to 32 mm (7/8 to 1-1/4 in).

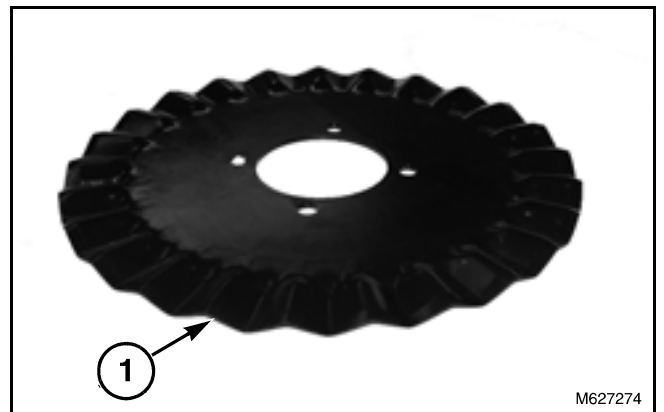

FIG. 28

ASSEMBLY SAFETY



CAUTION: To avoid personal injury, read, understand and follow the safety information below.

- Wear personal protective equipment (PPE) such as, but not limited to, protection for eyes, lungs, ears, head, hands and feet when operating, servicing or repairing equipment.
- Use lift crane, jack, tackle or fork-lift truck to lift heavy parts and assemblies.
- Assembly area must be level, clean and free of debris to prevent assembly personnel from tripping or falling.
- Neatly arrange parts and tools within easy reach of work area.
- Inspect all parts for sharp edges, grease, oil or dirt, which can cause injury during assembly.
- After completing each assembly step, review next step in procedure before proceeding with that step.
- If machine requires blocking up, use blocking material of adequate strength and in good condition. Blocks must be on a smooth, dry and level surface.
- Never place any part of your body under blocked-up assemblies if at all possible.
- If welding or flame cutting is required, make sure no flammables are in area. Also, clear bystanders from area.
- Make sure all fittings are tight and all lines and hoses are in good condition and not damaged during installation.
- Always use a piece of wood or cardboard to detect fluid leaks. Wear gloves and safety glasses. Escaping hydraulic fluid, under extremely high pressure, can penetrate the skin and cause blood poisoning. If injured by escaping fluid, see a doctor immediately.
- Correct fluid leaks before using equipment.

BEFORE DELIVERY

- After completing assembly of the machine, make sure all nuts, bolts, other fasteners, and hydraulic fittings are properly tightened.
- Make sure all safety guards and safety locking devices are in place.
- Make sure the machine is completely lubricated.
- Before operating the machine, make sure to read the Operation Section of the operator's manual.
- Before delivering the machine, review machine maintenance, operation, and safety with the customer.
- Complete the Pre-delivery Inspection and Service Report at the end of these instructions.

NOTE: Many attachments are available for planters. Time savings can be achieved by installing some attachments before fully assembling planter.

SEED TRANSMISSION FOR GROUND DRIVE

Sprocket Cluster Assembly

Insert the cap screw in the largest sprocket and lay on the bench. Using a sprocket shaft as a guide, install the smaller sprockets in descending order. Tighten the nuts to 13.6 Nm (120 in lb).

NOTE: The sprocket hubs on the sprocket cluster must face the center of the transmission to permit the chain alignment when the cluster is moved to the left.

Seed Transmission Drives, Idlers, and Chain Routing

FIG. 20: Components of the seed transmission.

- (1) Idlers
- (2) Contact Drive Tire Axle

IMPORTANT: Excessive torsion force on the idlers will reduce the idler roller service life.

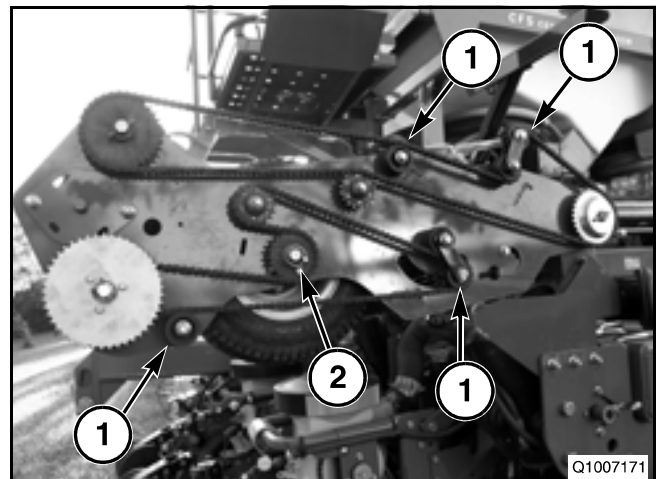

FIG. 20

FIG. 21: The components of the seed transmission continued.

- (1) Output Shaft
- (2) Counter Shaft

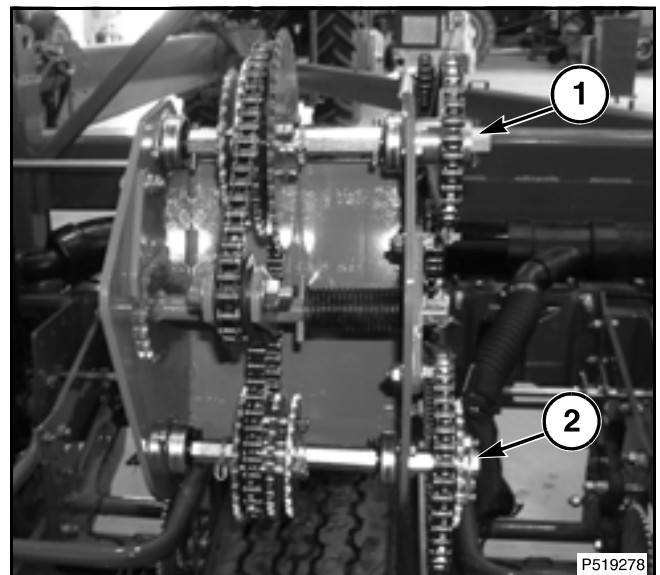

FIG. 21

ISOBUS PLANTER ELECTRONICS

Startup

Complete the following steps.

For tractors requiring a separate planter console

- Install the console in the tractor. See the console Operator Manual.
- Connect the radar to the console harness.
- Connect the master switch to the console harness. See the console Operator Manual.

All planters

- Check the planter harness and component connections. See Electronic Connection Checklist in this section.
- Connect the planter harness to the implement connector for the console.
- Turn on the console. The planter screens will download into the console. (Can take a few minutes)
- Set the console settings. See the console Operator Manual.
- Set up the master switch as an auxiliary input for the console (if available). See the console Operator Manual.
- Setup at least one material (A material is a seed type and planting rate). See Dual Drive ISOBUS Planter Electronics section in this manual.
- Set up Channel 1 and Channel 2. See Dual Drive ISOBUS Planter Electronics section in this manual.
- Do a Channel Calibration for both Channel 1 and Channel 2. See Dual Drive ISOBUS Planter Electronics section in this manual.
- Set the ground speed source on the Planter Ground Speed Calibration screen to CAN GROUND. See Dual Drive ISOBUS Planter Electronics section in this manual.
- Do a Ground Speed Calibration on the console. See the console Operator Manual.

CLICK HERE TO **DOWNLOAD** THE COMPLETE MANUAL

- Thank you very much for reading the preview of the manual.
- You can download the complete manual from: www.heydownloads.com by clicking the link below



- Please note: If there is no response to CLICKING the link, please download this PDF first and then click on it.

CLICK HERE TO **DOWNLOAD** THE COMPLETE MANUAL