

Betriebsanleitung

CE

Hydraulikbagger

RH 90C Nr.

Bucyrus HEX GmbH



CLICK HERE TO **DOWNLOAD** THE COMPLETE MANUAL

- Thank you very much for reading the preview of the manual.
- You can download the complete manual from: www.heydownloads.com by clicking the link below



- Please note: If there is no response to CLICKING the link, please download this PDF first and then click on it.

CLICK HERE TO **DOWNLOAD** THE COMPLETE MANUAL

Checking/cleaning the filter elements.....	113
Replacing the filter elements	113
High-pressure filter for the feeding circuit.....	114
Checking/cleaning the filter elements.....	114
Replacing the filter elements	114
Changing the hydraulic oil	115
Drawing/draining off the hydraulic oil	115
Cleaning the hydraulic oil reservoir	116
Filling in hydraulic oil	116
Venting the hydraulic system	117
Venting the hydraulic components	117
Cleaning the hydraulic oil cooler.....	118
Cleaning	118
Pressure accumulator - Emergency lowering	
Pressure-accumulator inspection regulations.....	119
Excerpt from the German regulations.....	119
Excerpt from the acceptance regulations	119
Checking the gas charging pressure in the pressure accumulator.....	119
PUMP TRANSFER GEARBOX	
Checking the gearbox oil level / Topping up with oil.....	120
Changing the gearbox oil	120
Draining off oil	120
Filling in oil	120
Gearbox venting.....	120
SLEWING GEARBOX	
Gearbox - Checking the oil level / Topping up with oil	121
Changing the gearbox oil	121
Draining off oil	121
Filling in new oil / Topping up	122
Gearbox venting.....	122
Venting bore	122
TRAVEL GEARBOXES	
Gearbox - Checking the oil level / Topping up with oil	123
Travel gearbox - Changing the oil	123
Draining off oil	123
Filling in oil	123
CRAWLER TRACKS	
Cleaning	124
Track rollers, support rollers.....	124
Track roller fastening	124
Support roller fastening	124

Organizational measures

The operating instructions must always be at hand at the place of use of the machine, e.g. by stowing them in the place provided for such purpose.

In addition to the operating instructions, observe and instruct the user in all other generally applicable legal and other mandatory regulations relevant to accident prevention and environmental protection.

These compulsory regulations may also deal with the handling of hazardous substances, issuing and/or wearing of personal protective equipment or traffic regulations.

The operating instructions must be supplemented by instructions covering the duties involved in supervising and notifying special organizational features, such as job organization, working sequences or the personnel entrusted with the work.

Personnel entrusted with work on the machine must have read the operating instructions and in particular the chapter on safety before beginning work. Reading the instructions after work has begun is too late. This applies especially to persons working only occasionally on the machine, e.g. during setting up or maintenance.

Check - at least from time to time - whether the personnel is carrying out the work in compliance with the operating instructions and paying attention to risks and safety factors.

For reasons of security, long hair must be tied back or otherwise secured, garments must be close-fitting and no jewellery, such as rings, may be worn. Injury may result from being caught up in the machinery or from rings catching on moving parts.

Use protective equipment wherever required by the circumstances or by law.

Observe all safety instructions and warnings attached to the machine.

See to it that safety instructions and warnings attached to the machine are always complete and perfectly legible.

In the event of safety-relevant modifications or changes in the behaviour of the machine during operation, stop the machine immediately and report the malfunction to the competent authority/person.

Never make any modifications, additions or conversions which might affect safety without the supplier's approval. This also applies to the installation and adjustment of safety devices and valves as well as to welding work on load-bearing elements.

Spare parts must comply with the technical requirements specified by the manufacturer. Spare parts from original equipment manufacturers can be relied on to do so.

Replace hydraulic hoses within stipulated and appropriate intervals, even if no safety-relevant defects have been detected.

Adhere to prescribed intervals or those specified in the operating instructions for routine checks and inspections.

For the execution of maintenance work, tools and workshop equipment adapted to the task on hand are absolutely indispensable.

The personnel must be familiar with the location and operation of fire extinguishers.

Observe all fire-warning and fire-fighting procedures.

PART 2 - OPERATION

	Operating manual	Target group
Part 1	INTRODUCTION FUNDAMENTAL SAFETY INSTRUCTIONS	Operating personnel + Inspection and servicing personnel + Repair personnel
Part 2	OPERATION	Operating personnel The operating personnel must have know-how relevant to the operation and the application of this or comparable machines.
Part 3	INSPECTION AND SERVICING	Inspection and servicing personnel The inspection and servicing personnel must have know-how relevant to the inspection and servicing of this or comparable machines.
Part 4	REPAIR WORK	Repair personnel The repair personnel must have know-how and experience relevant to the repair of this or comparable machines.
Part 5	ANNEX	Operating personnel + Inspection and servicing personnel + Repair personnel
Part 6	INDEX	Operating personnel + Inspection and servicing personnel + Repair personnel

□

Signs

The machine has been inspected and tested by authorized, independent testing agencies and bears the CE marking (Fig. 6) as a sign of conformity with EC directives.

Warning and instruction signs



Observe the warning and instruction signs attached to the machine.

Keep the signs clean and legible.

Replace any illegible signs immediately.

New warning and instruction signs can be ordered from the O&K-Mining Spare Parts Service. The parts numbers for ordering purposes are set out in the spare-parts list of the machine.

Fig. 6 shows the location of warning and instruction signs on the machine.

Machine number

The identification plate with the machine number is attached to the front side of the A-frame (arrow, Fig. 7, and Fig. 8)

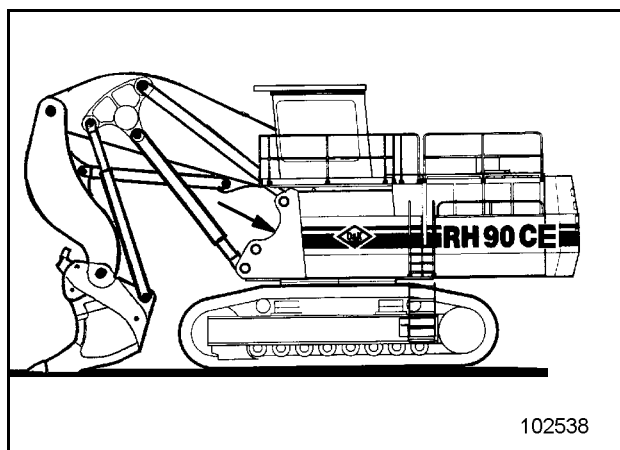

Fig. 7

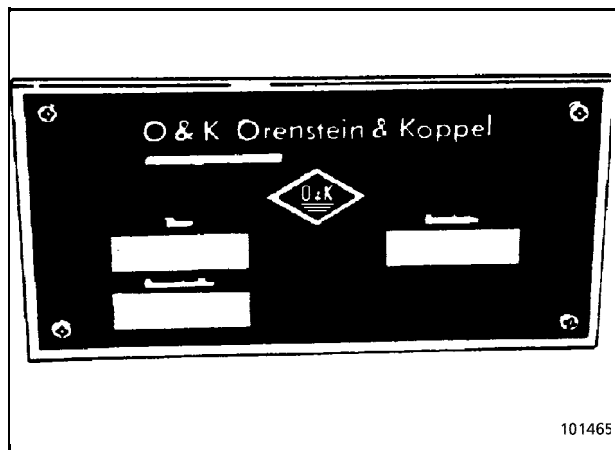

Fig. 8

Motor number

The identification plate (Fig. 9) with the motor number is attached to the electric motor.

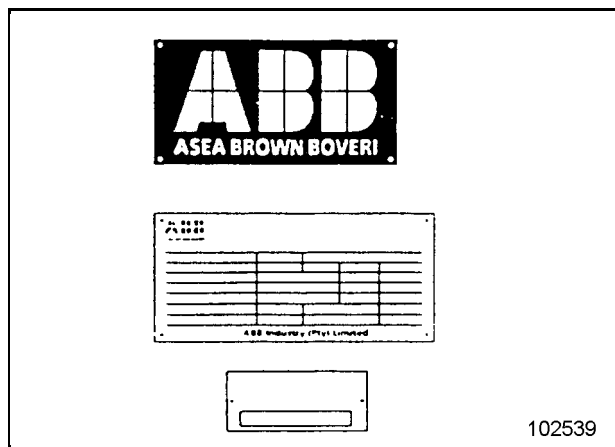





Fig. 9

Component numbers

Other larger units also have identification plates indicating, among other things, their serial number.

On steel components, the O&K-Mining part number or the serial number may be stamped into the metal at a clearly visible place.

(Fig. 3)

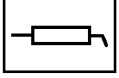
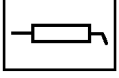
No.	Element	Function	Symbol
24	Warning light Main pump 1 contaminated	Lights up if the main pump is contaminated with metal particles.	
25	Warning light Main pump 2 contaminated	Lights up if the main pump is contaminated with metal particles.	
26	Indicator light	free for option	
27	Indicator light	free for option	
28	Warning light Hydraulic oil filter	Lights up if the flow resistance in the filter is too high. Replace filter element if warning light does not go out when oil is at operating temperature.	
29	Indicator light	free for option	
30	Warning light Slewing brake	Lights up if the slewing brake is engaged.	
31	Control lamp Lube system ON	Lights up if the lube system is switched on.	
32	Control lamp Lube system FAULT	Lights up if a fault occurs in the lube system.	
33	Indicator light	free for option	
34	Indicator light	free for option	
35	Indicator light	free for option	
37	Indicator light	free for option	
38	Indicator light	free for option	
39	Indicator light	free for option	

SWITCHING THE ELECTRIC MOTOR ON AND OFF

3 657 185

Before switching on the electric motor



Before switching on the electric motor, check that nobody is working on the electrical system or on the excavator itself.

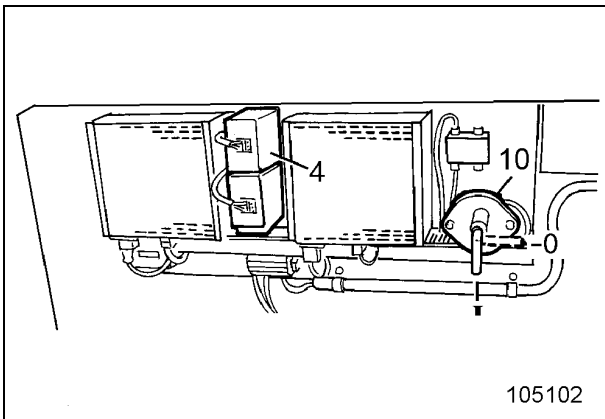

Fig. 1

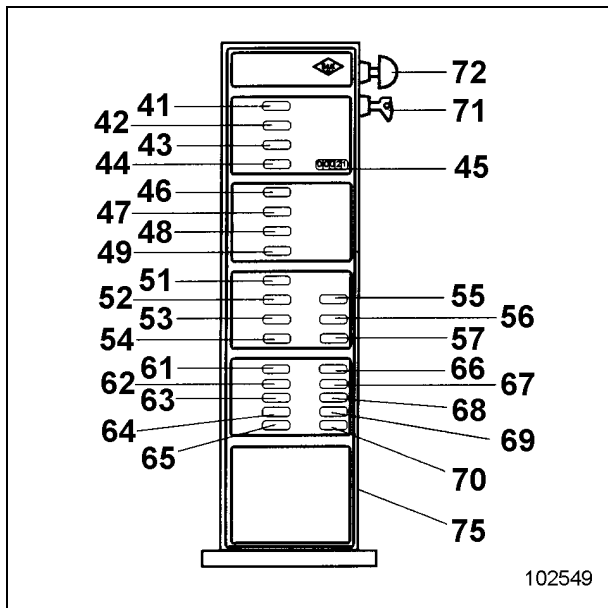

Fig. 2



The electric motor can be switched on and run only if the following safety interlocks are released:

- battery main switch (10, Fig. 1) ON
- EMERGENCY STOP mushroom-head pushbutton (72, Fig. 2) unlocked
- EMERGENCY STOP mushroom-head pushbutton (1, Fig. 3) unlocked
- circuit breaker (1, Fig. 4) ON.

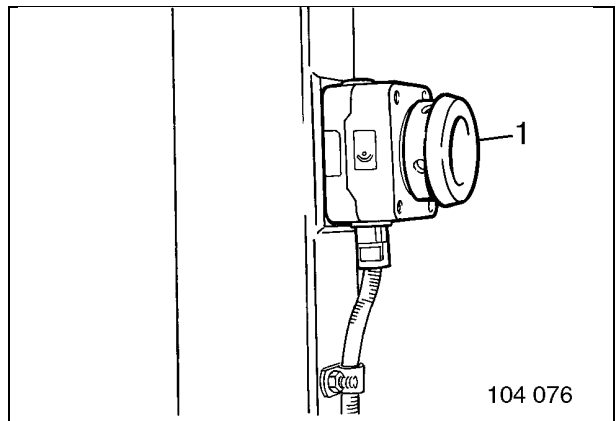

Fig. 3

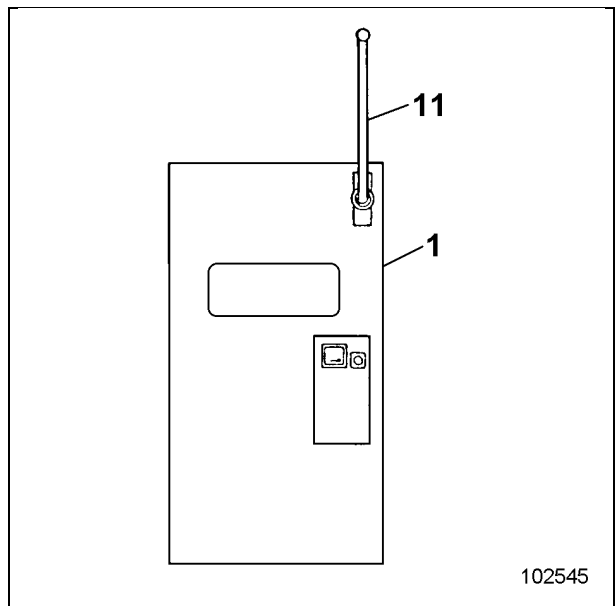

Fig. 4

Transporting the machine

2441641

Transport - Safety instructions



The machine must be loaded and transported only after all safety regulations have been observed and complied with.

Entrust loading and transporting of the machine to a company experienced in the transport of heavy equipment.

The responsibility for loading and transporting lies with the transport company or their representative.

Remove oil, grease, soil, mud, snow, ice and other materials from the excavator's crawler tracks and from ramps and loading platforms of the transport vehicle to minimize slipping.

Secure the transport vehicle against rolling away.

Use only tying equipment of sufficient strength (the weights and dimensions of the excavator are set out in the "Technical specifications").

Transport

The dimensions and the service weight of the fully assembled excavator do not allow the excavator to be transported in an undismantled state on a low-bed trailer over public roads.

Therefore, the following components and modules must be dismantled beforehand.

Weights and suspensions points are marked on the modules.

□

CLICK HERE TO **DOWNLOAD** THE COMPLETE MANUAL

- Thank you very much for reading the preview of the manual.
- You can download the complete manual from: www.heydownloads.com by clicking the link below



- Please note: If there is no response to CLICKING the link, please download this PDF first and then click on it.

CLICK HERE TO **DOWNLOAD** THE COMPLETE MANUAL

Inspection and servicing plans - Instructions

Intervals

The inspection and servicing plan lists all jobs which have to be done on the machine at regular intervals.

The individual inspection and servicing plans are marked with letters providing a link between the operating hours (OH) recorded by the hours-run meter of the machine and the inspection and servicing plans.

Meanings:

Plan	Do all jobs
V once prior to initial commissioning.
N after initial commissioning and during the running-in period.
T every 10 OH or every working shift ¹⁾ .
W every 60 OH or once a week ¹⁾ .
B after every 500 OH.
C after every 1000 OH.
D after every 5000 OH.
E after every 10000 OH.
¹⁾ Whichever comes first. OH = Operating hours	

Oils / Greases

For specifications of the oils and greases to be used, refer to the "Lubricants" section.

The numerals listed in the "Oil / Grease" column in the inspection and servicing plans have the following meanings:

I	Oils for combustion engines and compressors
II	Oils for hydraulic systems
III	Oils for gearboxes
V	Greases for bearings and slewing rings

Cleaning jobs

Cleaning jobs, especially on cooling systems, must be done at shorter intervals if the machine is exposed to severe dust build-up.

Plan A - after every 250 OH
(at 250, 750, 1250 ... OH)

Plan C - after every 1000 OH
(at 1000, 2000, 3000, 4000 ... OH)

Plan B - after every 500 OH
(at 500, 1500, 2500 ... OH)

Plan D - after every 5000 OH
(at 5000, 15000, 25000 ... OH)

Plan E - after every 10000 OH
(at 10000, 20000, 30000 ... OH)

Location	Servicing work	Quantity / No.		Plan B	Plan C	Plan D	Plan E
Pump transfer gearbox Breather filter	Have oil analysed	1	•	•	•	•	•
	Change oil	1 ²⁾			•	•	•
	Clean	1			•	•	•
Slewing gearbox Venting bore	Have oil analysed	2	•	•	•	•	•
	Change oil	2 ²⁾				•	•
	Check/clean	2			•	•	•
Travel gearbox Breather filter	Have oil analysed	2	•	•	•	•	•
	Check oil level	2		•	•	•	•
	Change oil	2 ²⁾				•	•
	Clean	2 x 1			•	•	•
Slewing ring Gearing/pinion Fastening screws (slewing ring, superstructure and undercarriage)	Check grease filling	1		•	•	•	•
	Check condition			•	•	•	•
	Check for tightness						•
	Torque wrench						•
Undercarriage Track roller Support roller Idler Crawler/undercarriage module	Check for leaks and free movement	2 x 8		•	•	•	•
	Check for leaks and free movement	2 x 2		•	•	•	•
	Check for leaks	2		•	•	•	•
	Check for tightness				•	•	•
Central lubricating system Grease sieve	Check/clean	1			•	•	•

²⁾ Cf. "Refilling quantities - Oil" table.



III. Oils for gearboxes (selection)

Ambient temperature		°F	-22	-4	+14	+32	+50	+68	+86	+104	+122	
		°C	-30	-20	-10	0	+10	+20	+30	+40	+50	
Specification												
API	MIL - L											
GL 5	2105 C	Multigrade Gear-Oil P/No.1 589 636										
GL 5 GL 4	2105 B 2105	GL 4 / GL 5 - 140										
		GL 4 / GL 5 - 90										
		GL 4 / GL 5 80 W										

8003091

Draining water from the switchgear cabinet.

Check switchgear cabinet (Fig. 13) for condensation.

Unscrew drain plugs (arrows, Fig 13) and drain off water.

 **The base of the switchgear cabinet (Fig. 13) must be kept clean.**

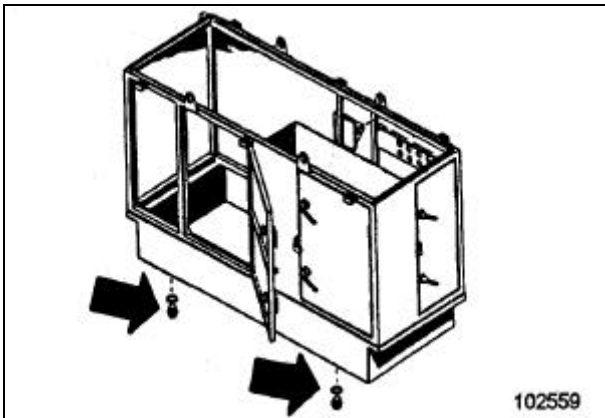

Fig. 13

Changing the hydraulic oil



Read and observe the "Inspection and servicing - Safety instructions" chapter.

Switch off the electric motor.

Risk of scalding caused by hot hydraulic oil.

The hydraulic oil reservoir itself may also be hot.

Avoid skin contact.

Skin contact with hydraulic oil may cause skin injury.

Wear protective gloves and firm working clothing.

Collect escaping oil and discard without polluting the environment.



Do not switch on the electric motor when the hydraulic oil reservoir is empty. The hydraulic pumps may be destroyed if they are allowed to run dry.

Drawing/draining off the hydraulic oil

- Bring the hydraulic oil to operating temperature (abt. 50 °C).
- Retract the hydraulic cylinders as far as possible and stand the working equipment on the ground.
- Switch off the electric motor.

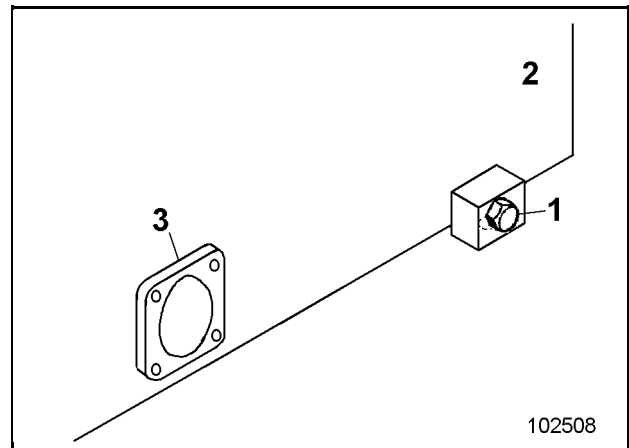

Fig. 19

Drain the hydraulic oil at express coupling (1, Fig. 19).

- Place suitable recipients under the drain valve (1) of the hydraulic oil reservoir. For the required capacity refer to the "Refilling quantities - Oil" table.

The use of the hose line is described in the "Hose line for oil and cooling-liquid changes" section.

Unscrew the hose line; the oil drain valve closes automatically

- Screw protective cap back in place

Track tensioner

Design

The tracks are tensioned with the help of the hydraulic pressure created during travelling. Figs. 4 and 5 show parts of the tracks and the tensioner:

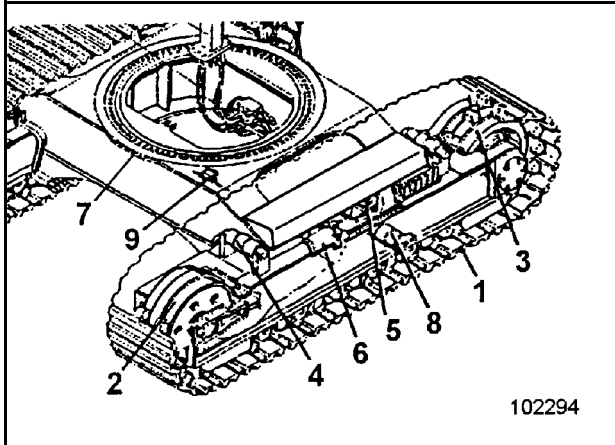

Fig. 4

- 1 Crawler track
- 2 Idler
- 3 Drive sprocket
- 4 Support roller
- 5 Pressure accumulator
- 6 Pressure cylinder
- 7 Pressure limiting valve
- 8 Track roller
- 9 Mini-measuring port

Technical data

Track tensioning pressure	approx. 60 bars
Pressure limiting valve	330 bars
Gas pressure in pressure accumulator (nitrogen filling pressure)	48 bars

Function

The tensioning system is under permanent pressure of ca. 60 bars which keeps both tracks permanently tensioned. Pressure losses are compensated as soon as the engines have been started. Retensioning is not required.

For cleaning and servicing work, the tracks can be slackened.

To do so:

- switch off the electric motor
- open both pressure limiting valves (7, Fig. 5) to slacken the tracks.
- After the work, screw down the pressure limiting valves (7) to the limit stop.

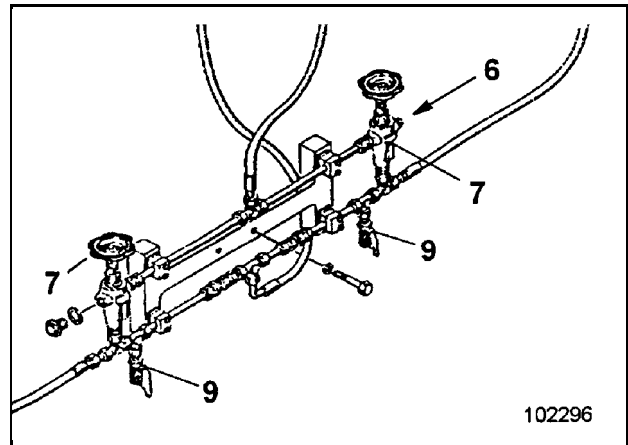

Fig. 5

The pressure-limiting valves (7) are preset to a pressure of 330 bars and sealed in this position. The lead seal must not be removed and the pressure setting of 330 bars must not be changed.

The track tensioners are maintenance-free.

Pressure governor

According to servicing plan, check that manometer (12, Fig. 6) shows 7.5 bar.
If this is not the case, then the pressure is to be re-set.

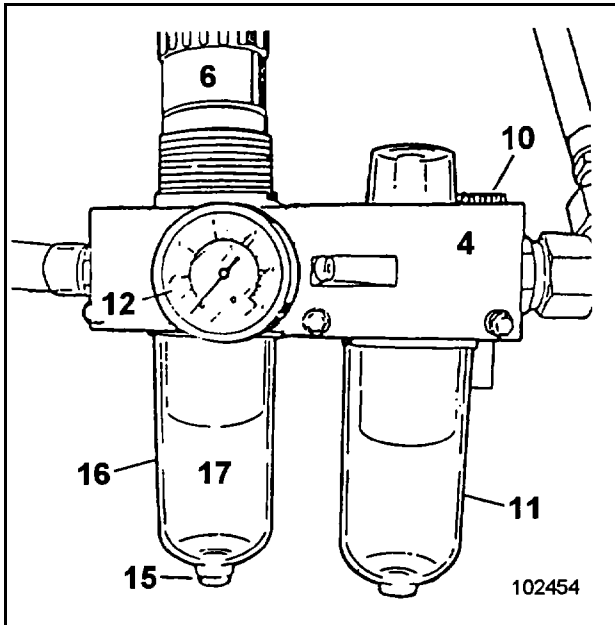

Fig. 6

Compressed-air filter

Drain condensation water according to servicing plan.

To drain, actuate pin (15, Fig. 6) several times until all water has drained.

Clean filter according to servicing plan.

For this unscrew housing (16) and remove filter insert (17).

Wash filter insert and housing in gasoline and blow out with compressed air.

When re-assembling, check seal ring between filter insert and housing for damage -change if necessary. □

Fire and Explosion Hazard

2800162



Safety Instructions

- Prior to commencing work, inform
- on the national and corporate rules for prevention of accidents. Pay particular attention to hazards caused by combustible and easily flammable substances.
 - on the safe handling of the fire extinguishers to be used.

Avoid smoking and open fire on, next to and below the excavator.

Combustible and easily flammable substances or liquids increase the fire and explosion hazard.

Do not store or handle any flammable substances during operation.

Clean the excavator thoroughly, if possible, with a steam jet (rubber parts and electric components with compressed air - refer to information label), when, for example, oil, grease or cleaner was spilled.

Such substances may spontaneously ignite if they get into the vicinity of hot.

Even battery gases can ignite in open flames or fire.

Avoid parking the excavator in places where

- combustible substances such as coal dust or tar are present.
- open or smouldering fire may occur.

Remove the excavator from such an area where combustible or easily flammable liquids have spilled from the excavator onto the ground.

Flying sparks (caused by welding, flame cutting, grinding, electrical short-circuit) may cause fire on the ground that can spread to the excavator.



Place suitable fire guardings (fire barriers) if open fire or flying sparks cannot be avoided during repair work.

Apply special protection to cables, cable ducts as well as to hose and pipe lines.

If necessary, also cover the ground with fire-protective blankets.

Ensure sufficient ventilation.

Clean the excavator before starting a job.

Do not keep any fire extinguishers that are not suitable or have not been tested.

Do not extinguish flammable liquids with water. Use:

- dry-powder,
- carbon-dioxide or
- foam extinguishing compounds.

When getting into contact with burning substances, the fire-fighting water would abruptly evaporate and distribute the substance such as oil over a wide area. Water causes short-circuits in the electrical system.

DANGER TO LIFE

Call the fire brigade.

Have all your welding, flame cutting and grinding work approved.

□



Track drive - Fault table

Cause				Remedial action																													
No forward travel and no reversing possible				Check P Adjust E Replace W Top up A Reduce S Clean R Contact the 1) O&K Service																													
Maximum travel speed cannot be reached																																	
Insufficient traction power																																	
<table border="1"> <thead> <tr> <th colspan="4">Cause</th> <th>Chapter ref.</th> </tr> </thead> <tbody> <tr> <td>•</td> <td>•</td> <td>•</td> <td>Malfunction of pressure-relief valve</td> <td>1)</td> </tr> <tr> <td>•</td> <td>•</td> <td>•</td> <td>Servo system pump defective</td> <td>1)</td> </tr> <tr> <td>•</td> <td>•</td> <td>•</td> <td>Malfunction of travel valve (pedal)</td> <td>1)</td> </tr> <tr> <td></td> <td>•</td> <td>•</td> <td>Malfunction of control spool</td> <td>1)</td> </tr> <tr> <td></td> <td>•</td> <td></td> <td>Hydraulic oil temperature too high oil cooler contaminated</td> <td>P/R</td> </tr> </tbody> </table>					Cause				Chapter ref.	•	•	•	Malfunction of pressure-relief valve	1)	•	•	•	Servo system pump defective	1)	•	•	•	Malfunction of travel valve (pedal)	1)		•	•	Malfunction of control spool	1)		•		Hydraulic oil temperature too high oil cooler contaminated
Cause				Chapter ref.																													
•	•	•	Malfunction of pressure-relief valve	1)																													
•	•	•	Servo system pump defective	1)																													
•	•	•	Malfunction of travel valve (pedal)	1)																													
	•	•	Malfunction of control spool	1)																													
	•		Hydraulic oil temperature too high oil cooler contaminated	P/R																													

CLICK HERE TO **DOWNLOAD** THE COMPLETE MANUAL

- Thank you very much for reading the preview of the manual.
- You can download the complete manual from: www.heydownloads.com by clicking the link below



- Please note: If there is no response to CLICKING the link, please download this PDF first and then click on it.

CLICK HERE TO **DOWNLOAD** THE COMPLETE MANUAL