

**Wheeled hydraulic  
excavators  
WX210 and WX240  
Tier 3**

Operator's Manual

87603842 EN

**CASE**

CLICK HERE TO **DOWNLOAD** THE COMPLETE MANUAL

- Thank you very much for reading the preview of the manual.
- You can download the complete manual from: [www.heydownloads.com](http://www.heydownloads.com) by clicking the link below



- Please note: If there is no response to CLICKING the link, please download this PDF first and then click on it.

CLICK HERE TO **DOWNLOAD** THE COMPLETE MANUAL

## INDEX

---

HYDRAULIC HAMMER SELECTION.....	7-1
SAFETY INSTRUCTIONS.....	7-1
USE OF HYDRAULIC HAMMER.....	7-3
HYDRAULIC SHEARS.....	7-8
SELECTING THE HYDRAULIC SHEARS.....	7-8
SAFETY INSTRUCTIONS.....	7-8
USE OF HYDRAULIC SHEARS.....	7-10
HYDRAULIC QUICK COUPLER.....	7-15
SAFETY INSTRUCTIONS.....	7-15
QUICK ASSEMBLY AND DISASSEMBLY.....	7-17
HANDLING OF LOADS.....	7-19
CLAMSHELL BUCKET.....	7-20
SAFETY INSTRUCTIONS.....	7-20
CLAMSHELL BUCKET ASSEMBLY.....	7-20
CLAMSHELL BUCKET DISASSEMBLY.....	7-22
PARAMETERS SETTING.....	7-23
SWITCHING OVER FROM STANDARD TO CLAMSHELL BUCKET.....	7-23
ROTARY CUTTER.....	7-25
SAFETY INSTRUCTIONS.....	7-25
USE OF THE ROTARY CUTTER.....	7-26
CRANING HOOK.....	7-30
SAFETY INSTRUCTIONS.....	7-30
USE OF THE CRANING HOOK.....	7-30
OVERLOAD WARNING SYSTEM.....	7-31
“MOZELT” MAGNET.....	7-33
SAFETY INSTRUCTIONS.....	7-33
SYSTEM.....	7-34
OPERATION.....	7-36
DISPLAY.....	7-37
BREAK PROTECTION VALVES.....	7-40
REAR FLOODLAMPS.....	7-41
ROTARY LIGHT.....	7-42
SINGLE LIGHT.....	7-42
DOUBLE LIGHT.....	7-42
SWITCHING ON AND OFF.....	7-42
FUEL TRANSFER PUMP.....	7-43
CAB PROTECTIONS.....	7-45
CAB LIFTING PLATFORM.....	7-45
BLADE PROTECTION.....	7-46
TRANSPORT BRACKET FOR CLAMSHELL.....	7-46
CENTRALIZED LUBRICATION.....	7-47
SAFETY INSTRUCTIONS.....	7-47
OPERATION.....	7-47
MANUAL FILLING PUMP.....	7-50
MOTORIZED FILLING PUMP.....	7-51

## OPERATING THE MACHINE

### USE HANDHOLDS AND STEPS

Falling is one of the major causes of personal injury.

When you get on and off the machine, always maintain a three-point contact with the steps and handrails and face the machine.

Do not use any controls as hand-holds.

Never jump on or off the machine.

Never mount or dismount a moving machine.

Be careful of slippery conditions on platforms, steps, and handrails when leaving the machine.

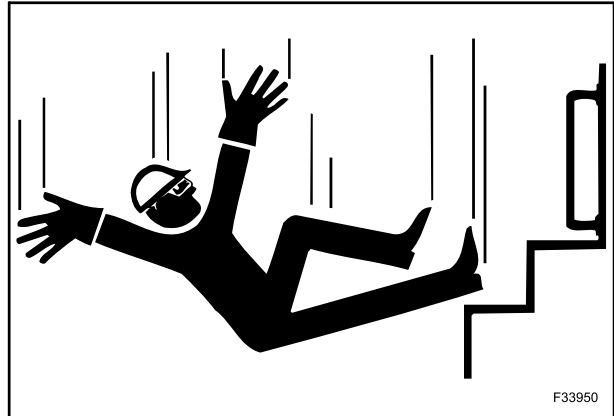

8

### ADJUST THE SEAT

A seat poorly adjusted for operator or work requirements may quickly fatigue the operator leading to improper operations.

The seat should be adjusted whenever machine operator changes.

The operator should be able to fully press the pedals and correctly move the control levers with his back resting against the seat back.

If not, move the seat fore and aft, and check again.



9

### DON'T CARRY RIDERS ON THE MACHINE

Riders on the machine are subject to injuries such as being struck by foreign objects and being thrown off the machine.

Only machine operator is allowed on the machine. Riders are not allowed.

Riders also obstruct the operator's visibility, resulting in the machine being operated unsafely.

## LOADING THE MACHINE ON A TRAILER

### WITH FRONT ATTACHMENT INSTALLED

Travel forward along the ramp with the front attachment at the front.

Once the ramp top has been reached, and before the machine starts falling forward onto the flatbed (shifting its centre of gravity), rest the bucket flat onto the trailer flatbed (the angle between the booms should be  $90^\circ$  to  $110^\circ$ ).

Travel slowly forward until the wheels are correctly positioned on the trailer flatbed.

Slightly raise the bucket from the flatbed, retract the dipper and keeping it tucked under, slowly swing the upper structure of  $180^\circ$ .

Retract the bucket and rest it on proper blocks (e.g.: wooden blocks).

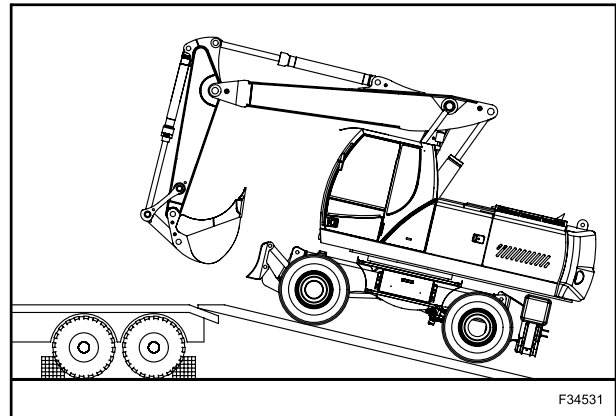

26

### WITHOUT FRONT ATTACHMENT

Travel in reverse along the ramp as shown.

Machine centre of gravity should correspond to the trailer centre of gravity.

Stop the engine and pull out the ignition key.

Cycle the hydraulic control levers to relieve any residual hydraulic pressure from the booms driving cylinders.

Move the safety lever to end of travel to the vertical lock position.

Close all windows, front windscreens, and cab door. Cover the exhaust pipe to prevent water or dirt from entering.

Secure the machine to the trailer correctly, so as to prevent dangerous movements, proceed as follows:

- lock the machine frame to the trailer flatbed by means of chains or metal cables of suitable size, avoid to involve metal cables or chains and paneling;
- lock wheels by placing wedges (chocks) under them;
- lock the front attachment (if installed) to the flatbed using chains or metal cables of suitable size.

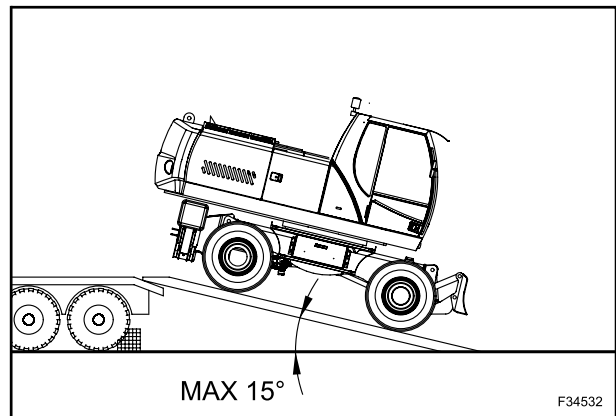

27

MONOBOOM ATTACHMENT

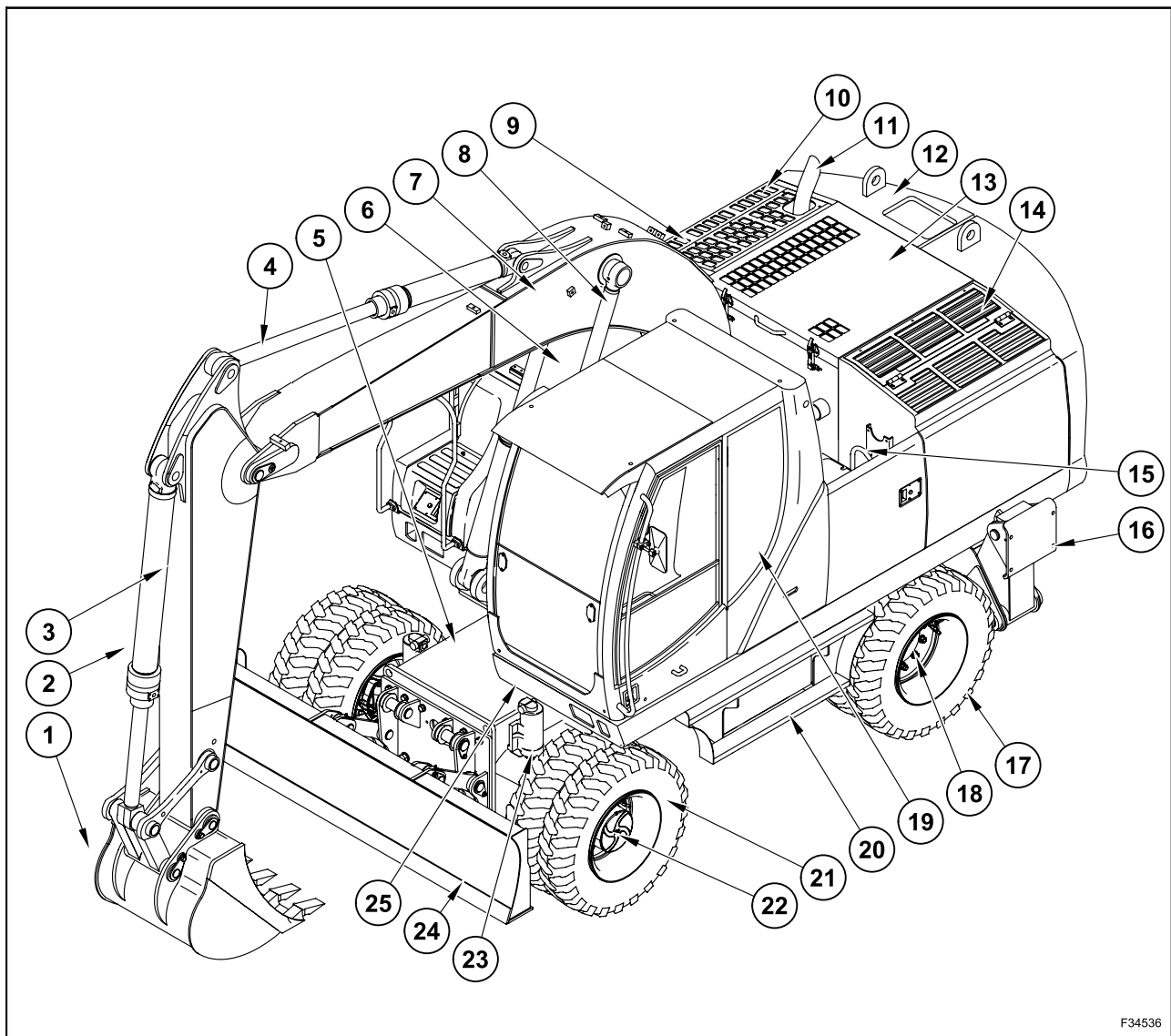

F34536

- |                       |                                     |
|-----------------------|-------------------------------------|
| 1. Bucket             | 14. Multi-cooler                    |
| 2. Bucket cylinder    | 15. Batteries                       |
| 3. Dipper             | 16. Stabilizers                     |
| 4. Dipper cylinder    | 17. Rear wheels                     |
| 5. Undercarriage      | 18. Rear rigid axle                 |
| 6. Fuel tank          | 19. Cab                             |
| 7. Boom               | 20. Stair and storage box           |
| 8. Boom cylinders     | 21. Front wheels                    |
| 9. Hydraulic oil tank | 22. Front steering axle             |
| 10. Hydraulic pumps   | 23. Axle floating locking cylinders |
| 11. Muffler           | 24. Upper structure                 |
| 12. Counterweight     | 25. Blade                           |
| 13. Diesel engine     |                                     |

**Slinging points**

This decal shows the slinging points for machine handling. Never use any other slinging points than those shown on this decal.

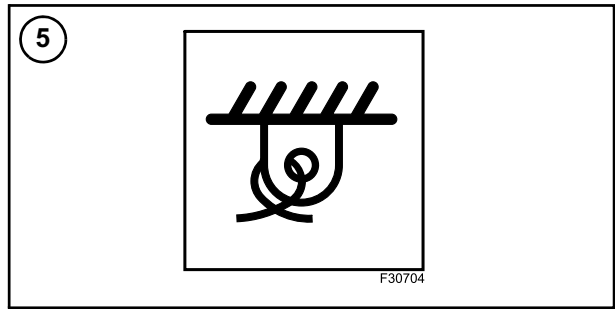

64

**Hydraulic oil tank**

This decal indicates the hydraulic oil tank. Make sure that the tank indicated by this decal contains exclusively hydraulic oil.

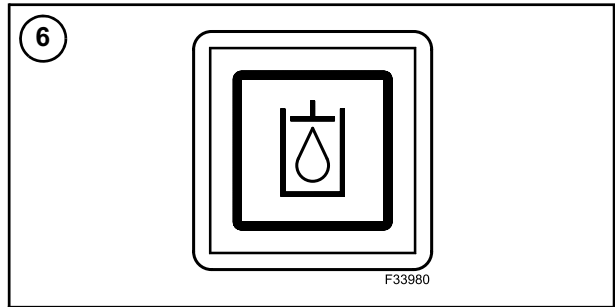

65

**Hydraulic oil tank**

Read this manual carefully to avoid the risk of oil under pressure inside of the tank in case of service.

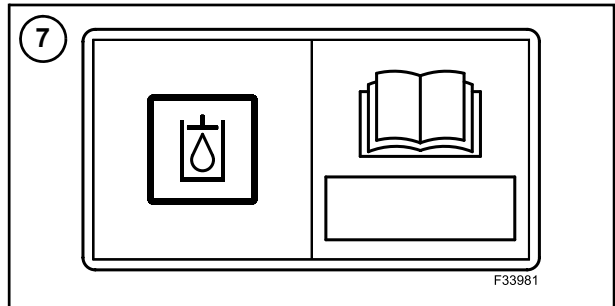

66

**Fuel tank**

This decal indicates the fuel tank. Make sure that the tank bearing this decal contains fuel only.

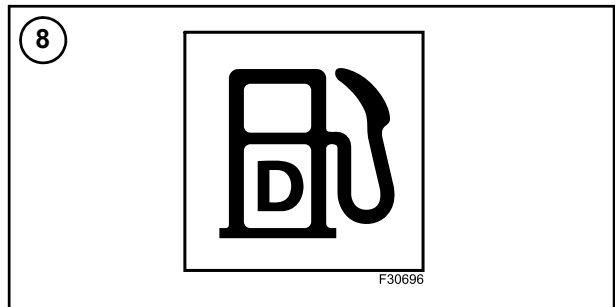

67

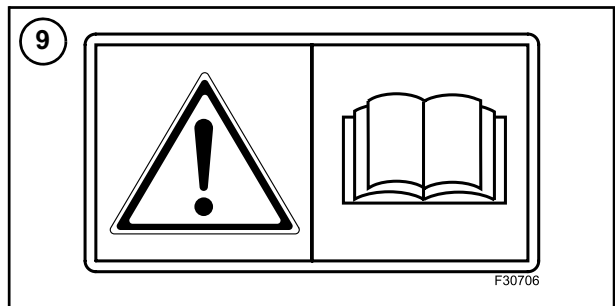

**Operator's Manual**

This decal shows the manual location. Read the manual carefully to ensure you operate the machine correctly.



68

SECTION 2

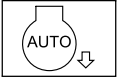
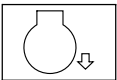
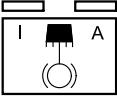
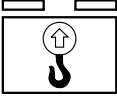
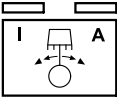
Ref.	Description		Operation	Symbol
14	Push-button	Engine rpm	Engine speed increase up to a maximum speed in 7 steps (7 power stages with fixed speed levels).	
15	Push-button	Engine rpm	Lowering of engine rpm up to idle run in 7 stages.	
16	Push-button	Auto Idle	Activation/deactivation of automatic engine speed reduction. After activation, the speed of the diesel engine is automatically reduced to a lower speed during no-work phases lasting longer than 4 seconds.	
17	Push-button	Low Idle	Sets engine to idling speed. If Auto Idle and Low Idle are on at the same time, Low-Idle has higher priority.	
18	Push-button	Upper structure holding brake	Push-button with two lights and three engagement positions. Lights off: brake released, upper structure free to turn. Left light on: holding brake engaged, upper structure braked. Right light on: holding brake automatic mode. Holding brake is applied and released automatically. As soon as the upper structure stops the brake applies.	
19	Push-button	Overload (optional)	Push-button with two lights and three engagement positions. Lights off: overload warning system off. Left light on: overload warning system on (machine not additionally stabilized). Right light on: overload warning system on (machine additionally stabilized).	
20	Push-button	Upper structure holding brake	Push-button with two lights and three engagement positions. Lights off: soft braking of upper structure slewing. Left light on: standard braking of upper structure slewing. Lights on: abrupt braking of upper structure slewing.	

SECTION 2

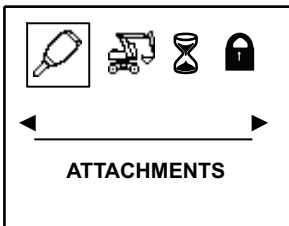
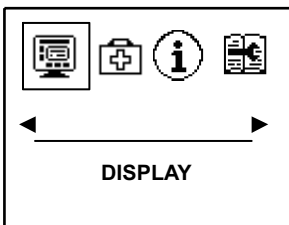
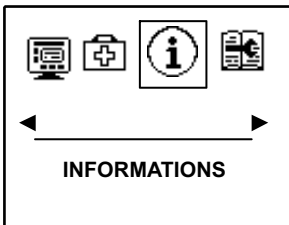
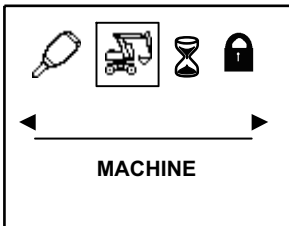
Ref.	Description		Operation	Symbol
8	Display	Attachments	<p>Setting of hydraulic oil pressure and of volumetric flow for the following attachments:</p> <ul style="list-style-type: none"> <li>- 4 different hydraulic hammers;</li> <li>- 4 different rotary cutters;</li> <li>- 4 different hydraulic shears.</li> </ul> <p>Further options can be activated by the dealer for use by the operator:</p> <ul style="list-style-type: none"> <li>- degree of damping for equipment movements and travel function;</li> <li>- slewing power limiting;</li> <li>- activation of "Auto Power Boost" function;</li> <li>- setting of the levelling function;</li> <li>- basic setting;</li> <li>- clamshell rotation;</li> <li>- Boom adjusting cylinder speed.</li> </ul>	
		Display	<p>Setting of display contrast and brightness, clock, language and measuring units.</p>	
		Informations	<p>Displays operating data of the machine and the control system.</p>	
		Machine	<p>Display of all machine data.</p>	

**TIME**

For different reasons time may need to be set in the electronic control unit and visualized on the display (for instance in case of legal time change).

In operating mode depress repeatedly the arrow button, until on main menu appears "display" on grey background. Confirm with "set" button (2).

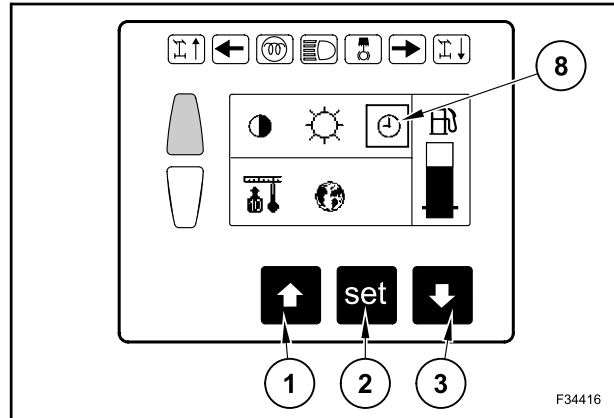

15

Depress repeatedly button with downward arrow (3), until the time symbol (9) appears on grey background (8). Confirm the setting with "set" button (2).

On the display left appears now the symbol of a clock and right the selection of:

- the indication of the 12 hours;
- the indication of the 24 hours;
- the date setting.

By means of the arrow button you can select one of these options and confirm the selection with "set" button (2).

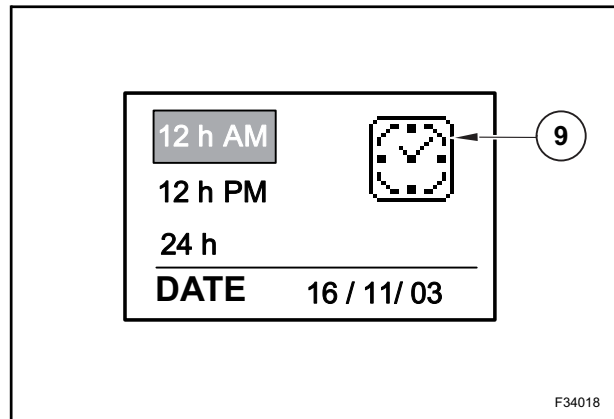

16

## DOOR OPENING

### Opening the door from outside

Unlock the door with key (1).

Withdraw the flap (2) on the door lock.

The door can now be opened.

Fully opened, the door can be locked into place.

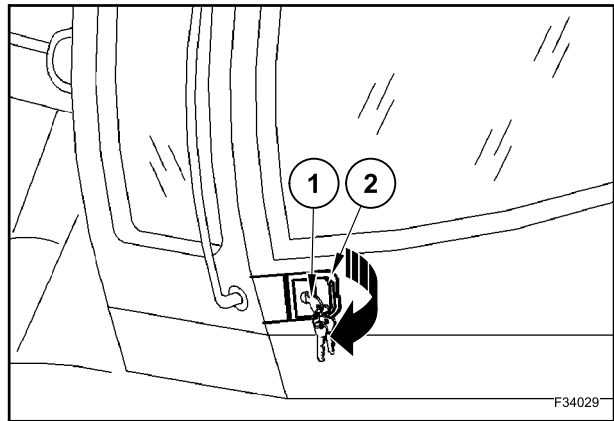

30

### Opening the door from inside

To open the door from inside, push lever (3) forward.

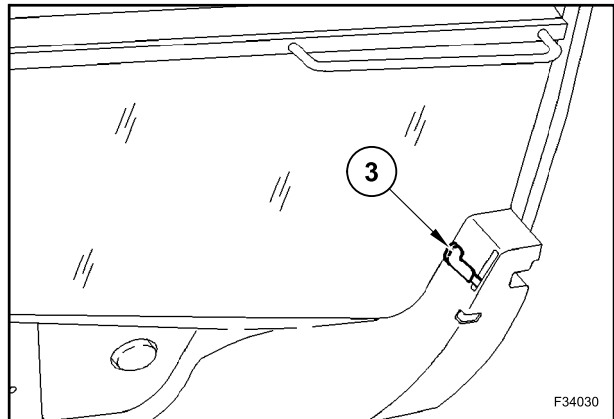

31

## DOOR CLOSING

Unlock the opened, locked-in door by pushing down the lever (1). Grab the handle (2) on the upper side of the door frame and close the door.



Make sure that the doors are correctly closed before any travel.

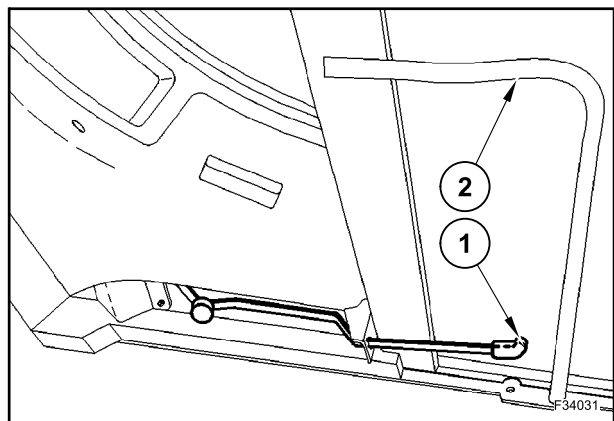

32

## HEATING

The engine coolant flows through the heat exchanger of the heating system. The heating output is therefore also dependent on the engine temperature. The full heating output is not achieved until the engine has run up to operating temperature.

Even if the heating is not required for an extended period, switch heating system on at full output once a week for about 5 minutes in order to mix the coolant in the engine and that in the heating system.

When working in dusty, severely contaminated air, the heating system can be operated temporarily in the circulating air mode (only with optional air conditioner).

Turn rotary knob (3) clockwise according to required heating output.

Depending on the quantity of hot air required, switch blower to stage 1 - 3 with rotary knob (1).

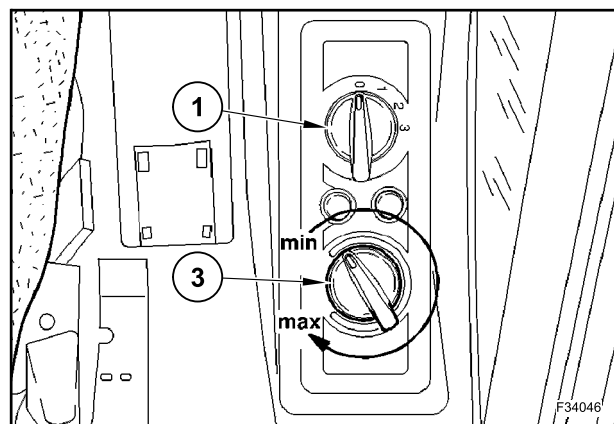

53

The slats of the air outflows (4) are adjustable. The air flow can thus be deflected laterally and upwards.

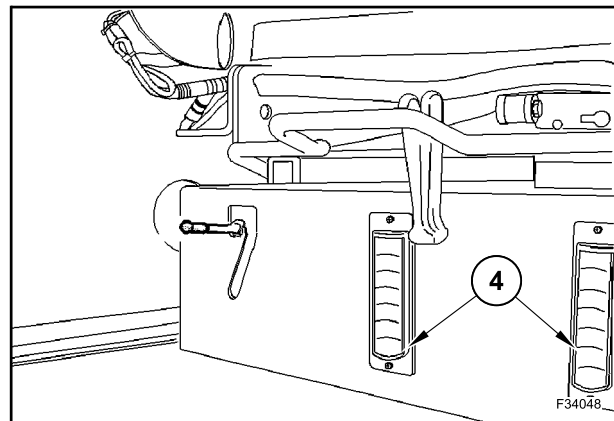

54

## SEAT BELT

### **⚠ WARNING ⚠**

Always fasten your seat belt before starting the engine. The machine is equipped with a roll over protection system (ROPS) which ensures your safety. The seat belt will protect you efficiently if you attach it correctly and if you always wear it. The seat belt must not be too loose. It must not be twisted or caught in the seat.

Check periodically the seat belt and all its securing elements. If you notice that the seat belt and its securing elements are damaged or some of them missing, perform immediately repair or replacement of parts. Seat belts damaged or worn because of an accident, they have to be replaced.

The seat belt buckle must not be clogged, for instance from paper or other objects, otherwise the hooking tongue does not lock. Never run belt over rigid or fragile objects such as bunches of keys or spectacles. In this way your body could get injured in case of accident. The operator's seat is fitted with a lap-type seat belt. The belt tensioning roller is incorporated on the left side of the seat.

### **FASTEN SEAT BELT**

Insert the hooking tongue (2) in the buckle (1). Pull the tongue against the buckle to check if the seat belt is well secured.

The belt should not be entangled or rolled.

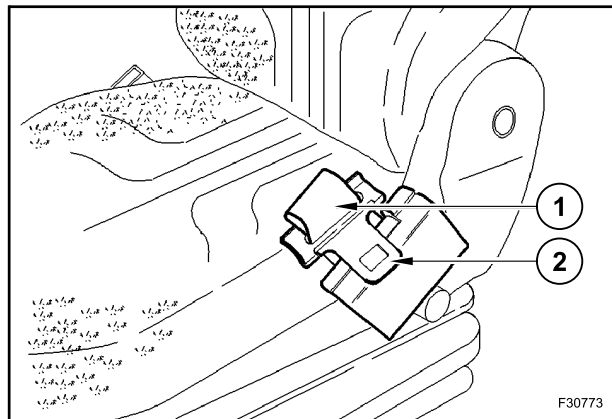

72

### **RELEASE SEAT BELT**

Press the lock (3) of the buckle (1) and take out the hooking tongue.

The belt rolls in automatically.

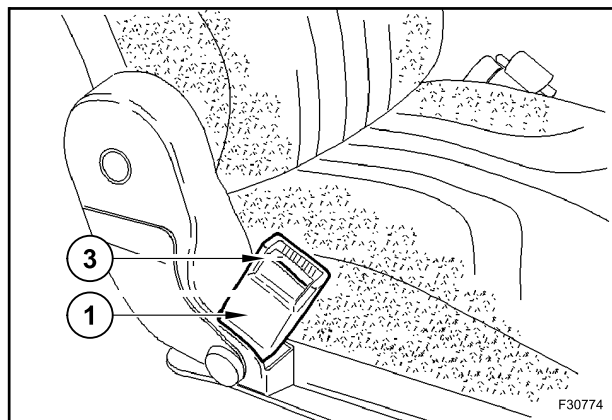

73

### ENGINE DOES NOT START

If the engine does not start, reset the ignition key to position "0" and repeat the start-up operation.

During this operation hold the key continuously to start-up position for at least 30 seconds. Between one start trial and the other observe a pause of 2 minutes.

If the engine does not start even after three attempts, check the fuel supply. The absence of blue or white smoke from the exhaust tube during start-up, indicates that the engine receives fuel.

Watch for the fault messages.

Maybe there is water in the fuel.

Drain water and try to start the engine again. If, after all, the engine fails to start, address to the After-sales service.

### ASSISTED STARTING (JUMP-STARTING)



Keep any potential ignition sources, such as unshielded lights or burning cigarettes, away from the batteries. Battery gases are readily flammable. A high current flows on connection of the earthing cable. Sparks occurring at the contact point may ignite gases at the discharged battery.

The ground clamp should therefore be connected as far as possible from the discharged battery.

Never lean over the batteries when jump-starting a vehicle. Wear goggles.

Never use assisted starting when the batteries are defective or frozen.

Never connect batteries (battery sets) unless they have the same voltage.

Use only tested jumper cables with insulated terminal clips and an adequate lead diameter.

Ensure that the bodies of the supplying and receiving machines are not in contact. Otherwise a current flow might result from connecting the positive poles. Risk of short-circuiting.

Never use jumper cables with overvoltage, e.g. two or three batteries or booster units connected in series and generating voltages in excess of 12 V.

Never use welding generators or welding transformers as a source of current.

Position jumper cables in such a way that they cannot be caught by rotating engine components.

---

### BEFORE JUMP-STARTING

Switch off all electrical consumers in receiving machine (with discharged battery) and turn ignition key to position "0".

Switch off all consumers in supplying machine (booster battery) and shut off engine.

The charge of the batteries supplying electric power should not be lower than the charge of the flat batteries.

### GEARBOX - GEAR CHANGE

According to the machine operation kind, you can afford different operation types at gear change:

- 1st speed: left light on button (1) lit and right light out;
- 2nd speed: left light out and right light on;
- automatic gearshift active: both lamps are out.

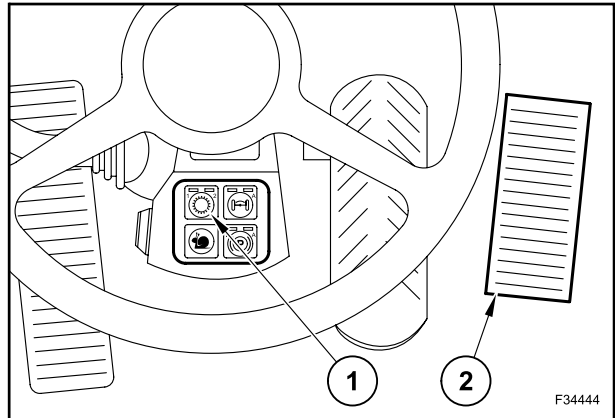

25

When the pedal (2) is activated, in the middle of the lower section, the display shows the symbol of gear engaged [the tortoise (A) = 1st speed or the hare (B) = 2nd speed].

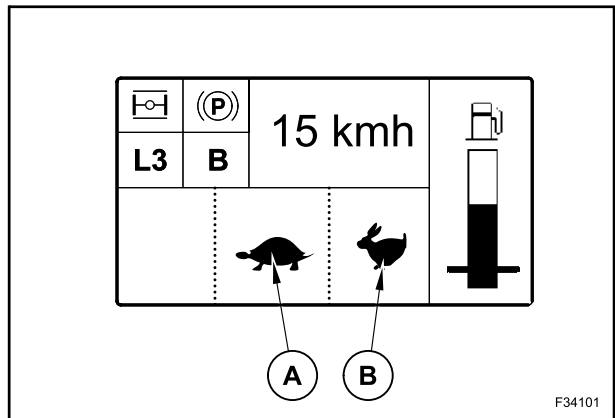

26

### CREEP SPEED

The engagement/disengagement of the creep speed is possible only at a travel speed lower than 20 km/h (12.43 mph). The creep speed can be engaged/disengaged with button (3) (the right lamp lights up at creep speed engagement). At the same moment, on the display bottom right, the snail symbol (C) appears. The speed of the relevant speed engaged, lowers of about 80%.

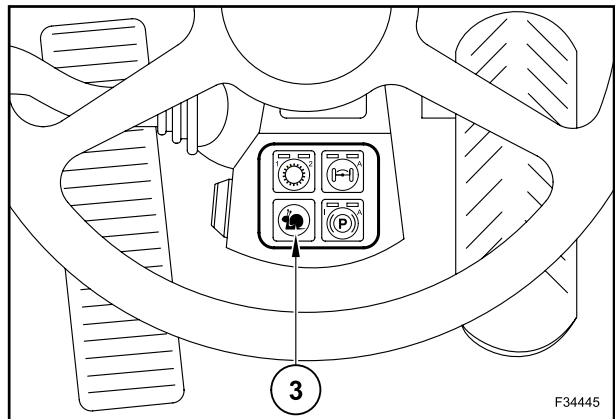

27

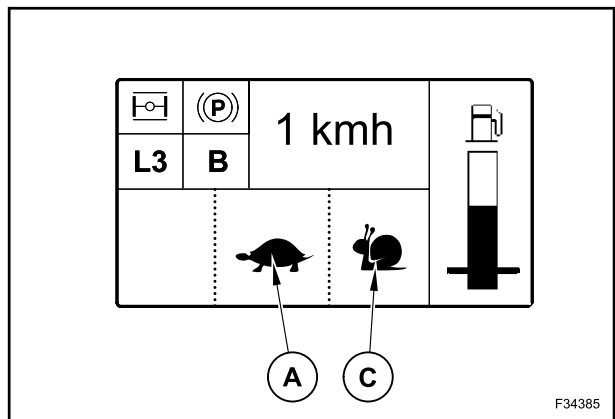

28

## HOLDING AND RELEASING THE UPPER STRUCTURE SLEW

### UPPER STRUCTURE HOLDING

Return the machine to basic position.

the locking pin (1) is set right above the opening of the undercarriage.

Lift the pin (1), turn it away from the seat and push it downward.

The locking pin engages in the opening of the carriage. If the locking pin cannot be turned at all or only with difficulty, slew the upper structure slowly to the left or to the right. Meanwhile push the locking pin downwards.

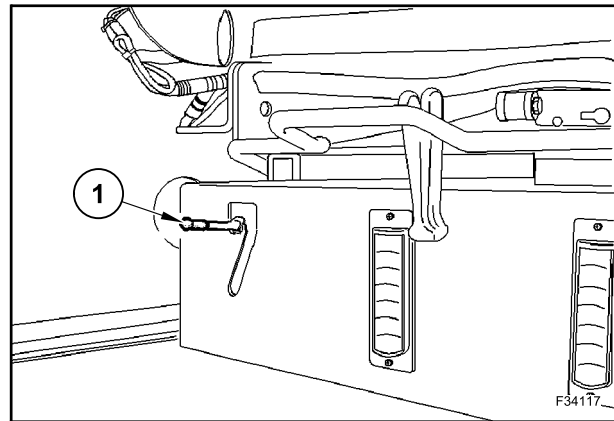

45

### RELEASING THE UPPER STRUCTURE

Pull up locking pin (1), turn towards the seat and engage.

If the locking pin cannot be turned at all or only with difficulty, slew the upper structure slowly to the left or to the right. Meanwhile pull the locking pin upwards.

### UPPER STRUCTURE HOLDING BRAKE

The slewing gearbox is equipped with a multi-plate brake. This is applied by spring pressure and released by hydraulic pilot pressure.

The upper structure holding brake can be applied at any time with button (1), (left lamp lit). The holding becomes active only after hydraulic control lever (2) is in neutral position and the upper structure slewing moving has come to a halt. About 3 seconds later, the "Holding brake" lamp (3) lights up on the display.

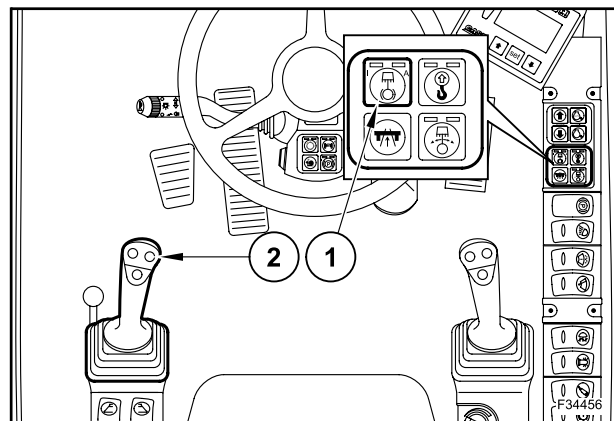

46

With ignition key is off, with engine shut off or in the event of system voltage failure, the upper structure holding brake is active. The upper structure is then braked.

The upper structure holding brake can be operated in the following three modes:

- right light on and left light out, by depressing button (1) only once: upper structure holding brake applied; it releases automatically when the left hydraulic control lever (2) is shifted toward one of the two rotation directions;
- left lamp on and right lamp out; upper structure holding brake always applied (necessary condition for road travel);
- left and right lights out: upper structure holding brake always applied.

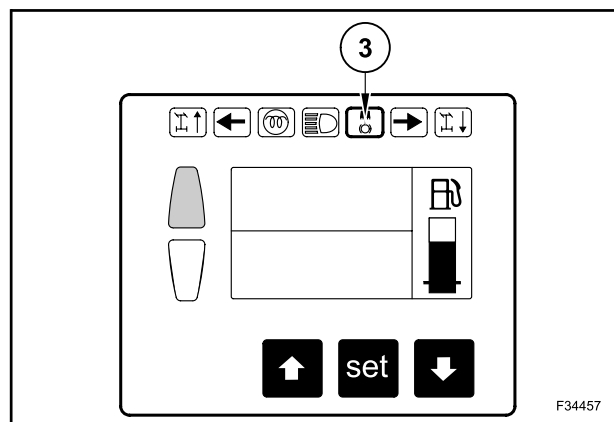

47

### HYDRAULIC DAMPING

By means of the hydraulic damping, the working movements acquire smoothness. Abrupt movements of the hydraulic control levers and travel pedal are converted into smooth machine movements.

The controls of boom, dipper, bucket and travel are in this way suited in the best way to the operator's ability and to the machine's operational state.

For instance:

- low damping: exact and progressive sequence of the hydraulic control levers movements, during building and craning works;
- high damping: smooth power boost or braking during the transfer movements.

### PARAMETERS SETTING

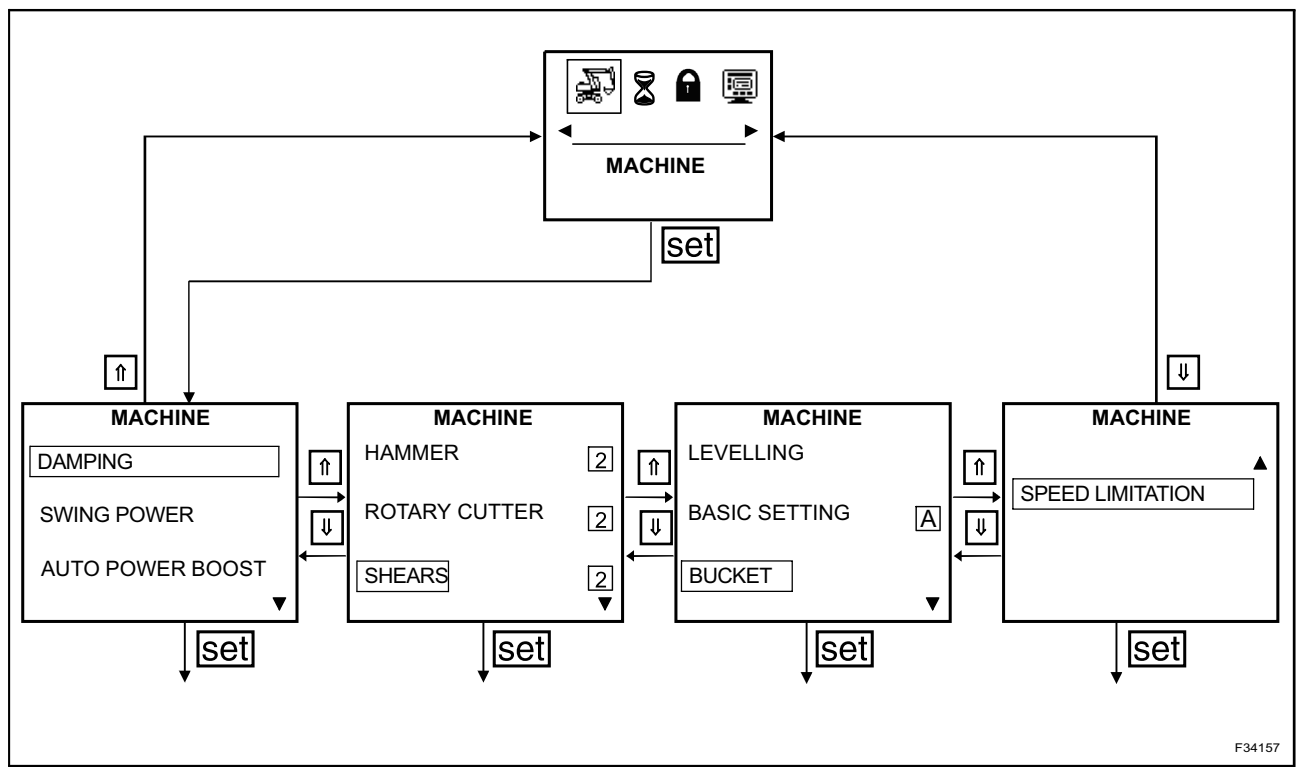

F34157

## OPERATING THE MACHINE WITH COLD WEATHER

### FUEL

Refill the fuel tank after each working day to prevent the formation of condensation and the entry of water into the fuel system.

To prevent the formation of crystals (-2 °C (2.84 °C)) use a low temperature fuel or mix a protective fluid with your fuel.

### LUBRICATING OIL

Select oil viscosity (SAE grade) according to ambient temperature before starting engine.

Increase oil change frequency when operating below -10 °C (14 °F).

### BATTERY

Efficient cold starting requires that battery is well-charged.

Starting limit temperatures can be lowered by 4 to 5 °C (39.2 or 41 °F) by heating batteries up to about +20 °C (68 °F) (to do so, remove batteries and store in warm place).

### COOLANT

When temperature approaches to 0 °C (32 °F) it is necessary, to avoid the hazard of freezing, to check whether the cooling circuit is filled with anti-freezing mixture: otherwise, replace the coolant of radiator with this mixture.

We recommend to use AGRIFLU coolant liquid, see in the table hereunder the mixture percentages according to outer temperature:

Outer temperature (up to ...)	AGRIFLU	Water
- 8 °C (17.6 °F)	20%	80%
- 15 °C (5 °F)	30%	70%
- 25 °C (- 13 °F)	40%	60%
- 35 °C (- 31 °F)	50%	50%

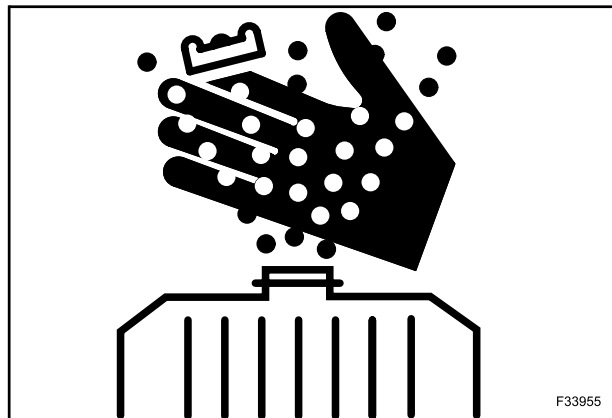

F33955

**SETTING OF BOOM ADJUSTING EQUIPMENT**

With this menu, it is possible to suit the working speed of the adjusting cylinder to the operator personal requirements and particularly to the work requirements. During this operation the pedal control radius is adapted (1).

The setting, described hereunder, influence the retraction and the extension of the adjusting cylinder.

In the working mode, depress repeatedly an arrow button until "MACHINE" appears in the lower part of the display and the machine symbol is marked by a frame. Depress "set" button.

To get back to the "MACHINE" menu, depress the button with the upward arrow (↑) or downward arrow button (↓), until the beginning or the end of the display selection is reached. When scrolling is continued on reaching the beginning or the end of the list, the program returns to the next higher menu. The return to the next higher menu is automatic if the buttons are not pressed for a prolonged period.

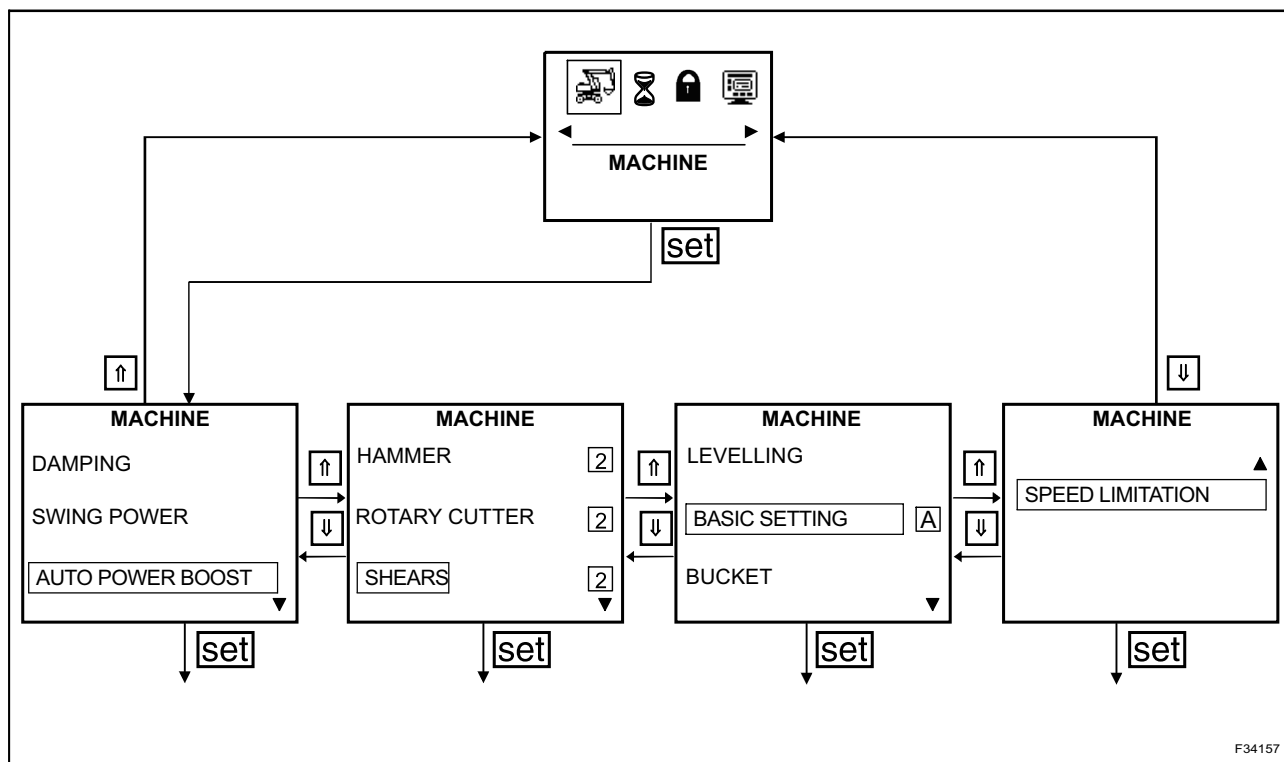

F34157

CLICK HERE TO **DOWNLOAD** THE COMPLETE MANUAL

- Thank you very much for reading the preview of the manual.
- You can download the complete manual from: [www.heydownloads.com](http://www.heydownloads.com) by clicking the link below



- Please note: If there is no response to CLICKING the link, please download this PDF first and then click on it.

CLICK HERE TO **DOWNLOAD** THE COMPLETE MANUAL

### BIODEGRADABLE HYDRAULIC OIL

The hydraulic system of this machine can be filled at with environmentally compatible, biodegradable hydraulic fluid too (special equipment). Stickers with corresponding instructions are then attached to the machine.

This biodegradable hydraulic fluid "PANOLIN HLP SYNTH 46" has been tested by the Manufacturer and approved for application on the machines.

The biodegradable oil must be analyzed every 500 hours of work, to verify that it keeps its features. With special tools (the hydraulic hammer for instance) the analysis should be performed every 250 working hours.

Oil can be drawn for analysis by means of the sample-kit and the relevant instruction delivered by the Dealer.

The sample should then be sent by the customer to PANOLIN AG., that will carry out the necessary checks. The Dealer will care to inform the customer in case the oil has lost the necessary features for use.

**NOTE:** *should the Dealer inform the customer that oil has exceeded the service limits, this must be replaced. If this indication is not observed, the warranty may become void and null and the machine may get damaged.*

A change from mineral hydraulic oil to this biodegradable hydraulic fluid can be performed at a later date. Environmentally compatible biodegradable hydraulic fluid must not be simply poured away as normal waste. It must be disposed of in the same way as any used oil!

If hydraulic fluid seeps into the ground, the machine Owner and the Competent Authorities must be informed. The use of PANOLIN HLP SYNTH 46 is restricted only to hydraulic systems.

Do not mix this hydraulic liquid with oils of other makes; this kind of mixture will decrease the oil biodegradability.

**HYDRAULIC OIL TOP UP**

The hydraulic oil tank is slightly under pressure at about 0.3 bar.

As mentioned previously, before performing any top up of the hydraulic oil, it is important to relieve the residual pressure inside of the hydraulic system.

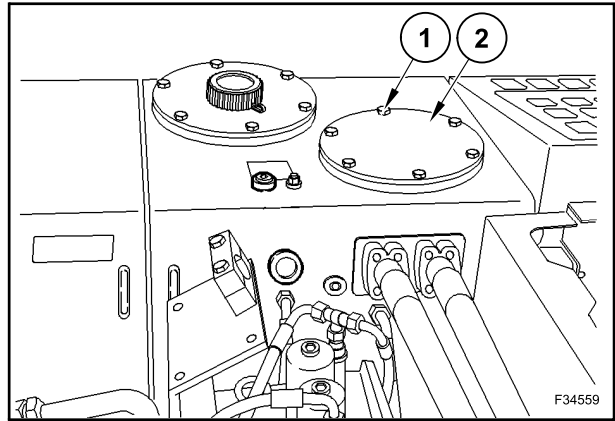

11

Unscrew the screws (1) paying attention to cover (2) that is under the spring (4) pre-load.

Reassemble the cover (2) with the spring (4) and the gasket (3).

In the filter housing can now be seen the return filter (5).

The top up has to be performed by letting the oil flow through this filter, until the oil level sets between references "min" and "max" of dipstick.

Before replacing the cover (2), check the gasket (3). If this is damaged, replace it.

Reassemble the cover (2) with the gasket (3) and the spring (4).

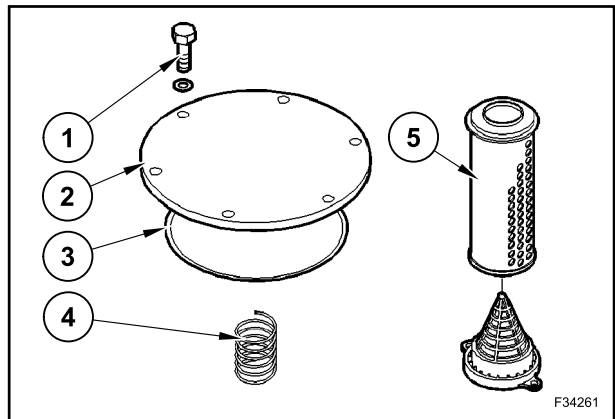

12

## TYRES - NUTS TIGHTENING

Park the machine on a flat surface and lower the equipment to the ground.

Shut off the engine.

Engage the parking brake.

Secure the machine by placing chocks under the wheels to prevent inadvertent movements.

Check if nuts (1) are tighten. Tighten to prescribed torque 450 Nm (331.90 lbf-ft).

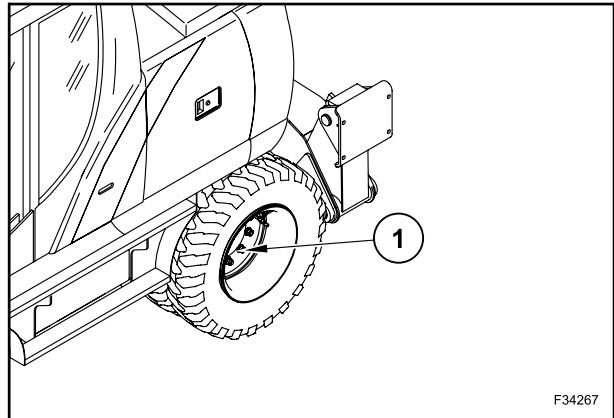

### **Quick recharge**

Respect the prescriptions of the Manufacturer of the battery charger.

Before performing the quick recharge, that is, a recharge with high density voltage, disconnect both connecting cables and disassemble the batteries.

Before performing the battery charge, unscrew the plugs to allow the release of gas from all battery cells.

A flat battery can freeze already at -10 °C (14 °F). If the battery is frozen, it must absolutely be defrosted before quick recharge; otherwise it could explode.

The battery charger net cable has to be plugged-in to the electric socket, only after the battery charger clamps have been correctly connected to the battery poles.

red = positive

black = negative

Once the recharge is complete, reinstall the battery and perform correct connection (first the positive pole and then the negative).

### BLADE AND STABILIZERS JOINTS, CARDAN SHAFT, STEERING TRUNNION PINS - GREASING

Before starting with the greasing operations place the machine in a safe condition.

By means of the greasing pump, grease all lubrication points.

Remove the protection cap from the grease nipple.

Clean the grease nipple.

Apply the pump nozzle on the grease nipple.

Now, pump the grease in such a quantity that the new grease can eject the old one from the articulation points.

Wipe off used grease with a cleaning rag.

After greasing, put protective cap back onto the grease nipple.

### BLADE AND STABILIZERS JOINTS

(1) = No. 12 grease nipples

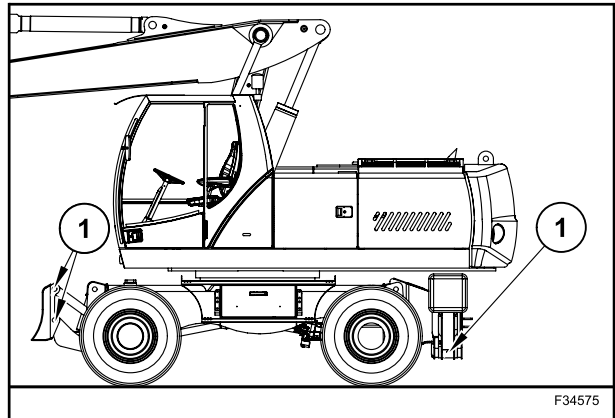

### CARDAN SHAFT

(2) = No. 2 grease nipples

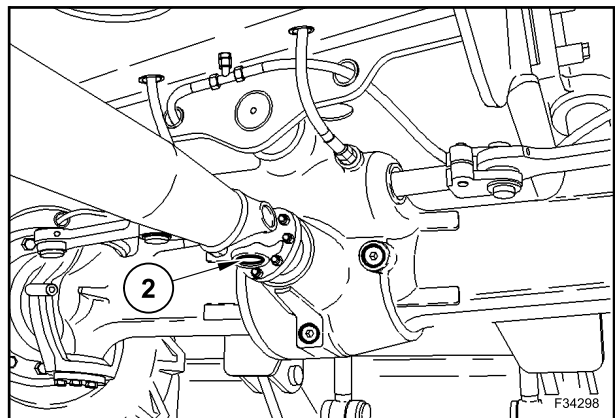

**HYDRAULIC SYSTEM BLEEDING VALVE - CHANGE**

The air bleeding and sucking valve (1) ensures this operation inside of the hydraulic oil tank (2), so as to compensate the hydraulic oil level floating.

This valve maintains a pressure of about 0.3 bar (4 psi) inside of the tank.

The valve (1) contains a filter element (4), that cannot neither be cleaned nor replaced. This is the reason why the valve has to be replaced completely.

The filter head is connected to the lower side, so as to be free to turn. In this way, you avoid that the valve is removed without authorization.

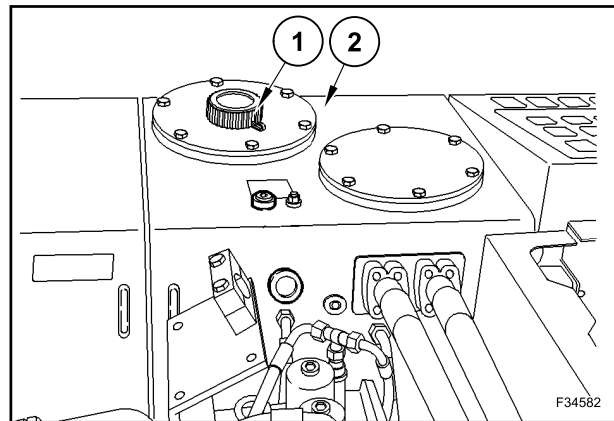

71

To unscrew the valve, insert laterally the locking pin (3), that is delivered with the new valve. Now the old valve has to be unscrewed with great care (the pressure inside of the hydraulic oil tank is released).

Insert the locking pin (3) inside of the new valve and tighten the valve manually.

Take out the locking pin and store it (for instance in the keys bunch) for a future use.

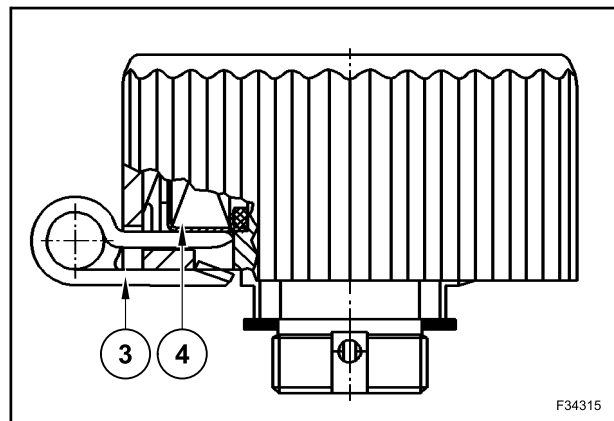

72

**STEERING AXLE - OIL CHANGE**



**WARNING**

The axle and the differential box may also be hot after a long journey.

Leave the axle and differential box to cool down and wear working gloves.

The axle and differential may be slightly over pressurized, so turn the control plug carefully, just far enough to release the excess pressure (audible hissing sound).

Collect the escaping oil and discard it without polluting the environment.

Park the machine on a level and firm surface.

Block the rigid axle wheels by placing chocks under them.

Raise the machine with the levelling blade or the working equipment until the wheels of the steering axle are clear of the ground and turn freely.

Shut off the engine.

Place the machine in a safe condition.

## SERVICE AFTER 3000 HOURS

SERVICE POINTS	Check	Oil change	Cleaning	Air bleeding	Replacement / Change
Oil tank		▼	⊗	○	
Engine - valves clearance	☐				
Cooling system liquid					■
Fuel tank			⊗		
Slewing gearbox		▼			

### HYDRAULIC OIL TANK - CLEANING AND OIL CHANGE

**⚠ WARNING ⚠**

Never let hydraulic oils to come in contact with the skin.

Wear protective gloves.

Collect escaping oil and discard without polluting the environment.

#### HYDRAULIC OIL DRAIN

**⚠ WARNING ⚠**

Do not start the engine if hydraulic oil has been drained.

By turning dry, the hydraulic pumps get damaged or broken.

Bring engine oil to operating temperature (about 50 °C (122 °F)).

Park the machine on a level and firm surface.

Retracting the cylinders as much as possible and lay the working attachment on the ground.

Shut off the engine.

Release the pressure from the hydraulic oil tank.

Place a collecting container under the hydraulic oil tank (1) and the multi-cooler.

Drain the hydraulic oil from the tank (1) by means of proper hose.

The oil drain sleeve (2) of the tank is accessible from the bottom through an opening on the counter-weight.

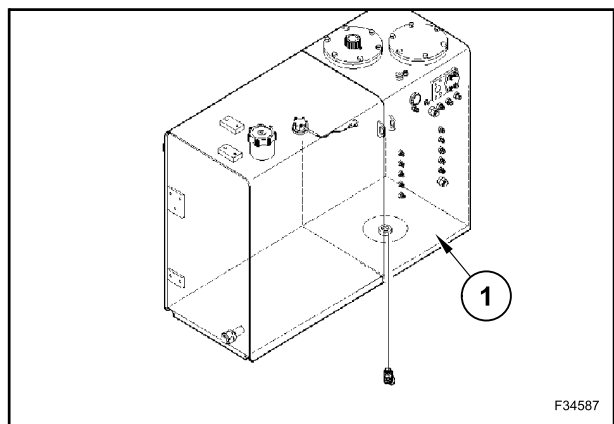

F34587

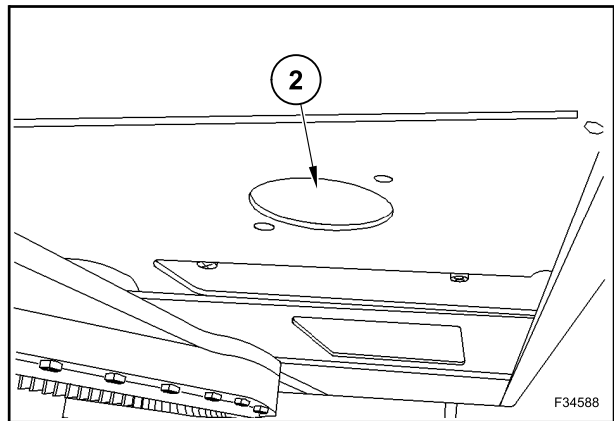

F34588

## INJECTORS - REPLACEMENT

Consult your Dealer.

## HYDRAULIC SYSTEM AND TANK - PRESSURE RELEASE



Only unpressurized hydraulic systems may be opened. Even if the machine is parked in horizontal position, with its attachment supported on the ground and the engine shut off, there may still be substantial residual pressure in parts of the hydraulic system:

- the primary pressure of the last hydraulic movements, before the machine stop.
- the secondary pressure, produced by the machine own weight or by the attachment single elements. The secondary pressure is present, until the component creating the pressure is set to rest position, for instance by means of mechanical supports, that allow to clear off the supporting function of the hydraulic system.

### HYDRAULIC SYSTEM PRESSURE RELEASE

Place the working attachment on the ground.

Shut off the engine.

Turn the ignition key to position "I" (ignition ON).

Activate the pilot control.

Activate both hydraulic control levers or pedals in both directions required for the works at hand.

Set the ignition key to position "0" (ignition OFF).

Disconnect the pilot control.

Before activating the cylinders, equipped with break protection valves, pay particular attention, because after the activation of the hydraulic control lever or pedals, some residual pressure may be present inside of the cylinder.

- On lifting cylinders with break protection valve at bottom side. This residual pressure can be discharged by lifting the undercarriage of about 10 cm (3.94 in).

During this operation the machine leans on the cylinder head side allowing the cylinder bottom to release the pressure.

- On adjusting cylinders with break protection valve at cylinder head side. This residual pressure may release, by retracting nearly completely the concerned cylinder and by lifting the undercarriage of about 10 cm (3.94 in) with the attachment completely extended. During this operation the machine leans on the cylinder bottom side allowing the cylinder head to release the pressure.

**FRONT WORKING FLOODLAMPS**

Remove the light from the cab roof.  
 With your fingers, compress the safety bracket (arrows) on connector (2) and remove the connector.  
 Unscrew the nut (1) with a spanner.  
 Remove working floodlamp (4) with the cap (3).  
 Holding the working floodlamp (4) still, turn the cap (3) to the left and remove it.  
 Press one side of the safety bracket (6) and move it upwards.  
 Replace the lamp (5).  
 Assemble by following procedure in reverse order.

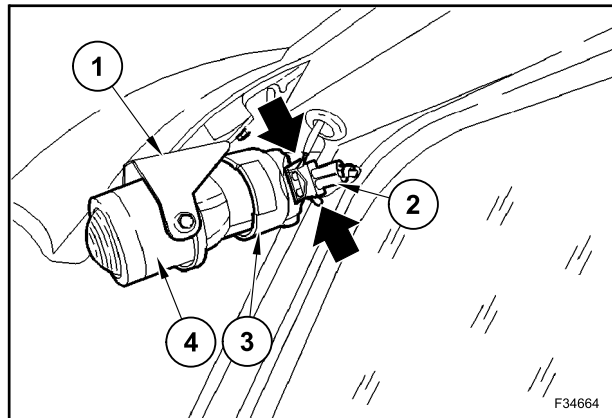

F34664

121

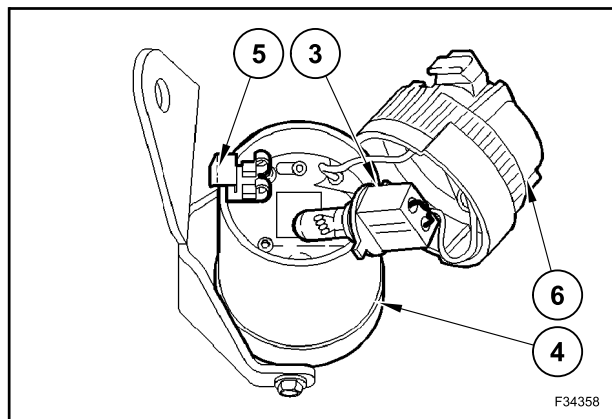

F34358

122

**BOOM WORKING FLOODLAMP**

Unscrew the fastening screws (1) of the covering glass (2).  
 Open the locking clamp (3) and replace the bulb (4).

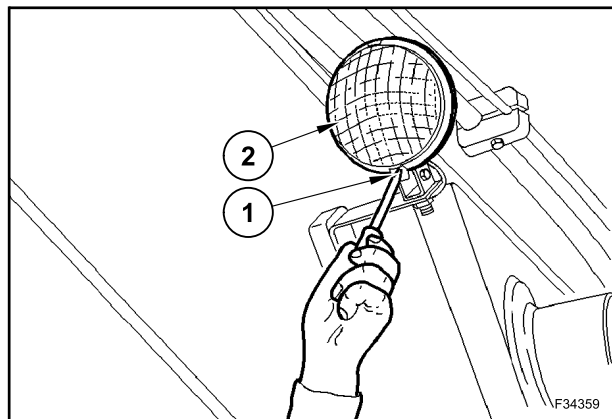

F34359

123

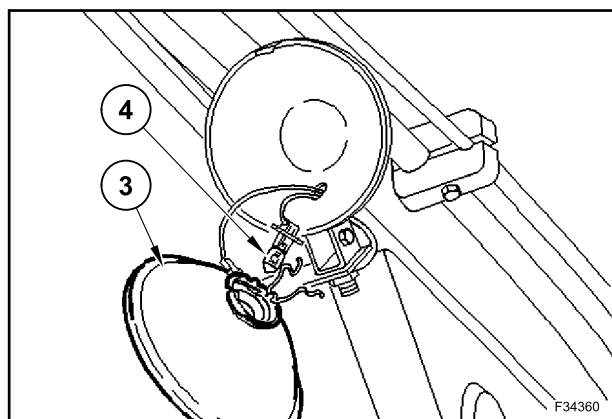

F34360

124

**SECTION 5**

<b>PROBLEM</b>	<b>POSSIBLE CAUSE</b>	<b>CORRECTION</b>
The engine runs irregularly or fails.	Fuel unsuitable. Air filter dirty or clogged. Fuel filter dirty or clogged.	Drain fuel tank and refill with fuel of correct type. Clean or replace the filtering elements. Replace fuel filter.
The engine overheats.	Multi-cooler dirty. Cooler fan faulty. Low coolant level. Wrong valves clearance. Injector/s dirty or faulty. Injection line leaks.	Clean cooler. Check and replace the cable. Add coolant. Consult your Dealer. Consult your Dealer. Check for leaks and rectify.
Engine output is poor.	Oil level too high. Fuel unsuitable. Air filter dirty or clogged. Fuel filter dirty or clogged. Leaks in the feeding system. Wrong valves clearance. Injector/s dirty or faulty. Injection line leaks.	Top up oil level. Drain fuel tank and refill with fuel of correct type. Clean or replace the filtering elements. Replace fuel filter. Check system hoses and fittings. Consult your Dealer. Consult your Dealer. Check for leaks and rectify.
The engine does not run with all cylinders.	Wrong valves clearance. Injection line leaks. Injector/s dirty or faulty.	Consult your Dealer. Check for leaks and rectify. Consult your Dealer.
Engine oil pressure is non-existent or excessively low.	Engine oil level low. Engine oil not suitable. Excessive inclination of engine.	Top up oil in correct quantity. Drain and refill with correct engine oil. Check and modify the engine position.
Engine oil consumption excessive.	Engine oil level too high. Excessive inclination of engine. Engine oil not suitable.	Decrease oil level. Check and modify the engine position. Drain and refill with correct engine oil.

**SECTION 5**

---

<b>PROBLEM</b>	<b>POSSIBLE CAUSE</b>	<b>CORRECTION</b>
Cylinder extends without control.	Non-return valves of cylinders defective operation.	Consult your Dealer.
	Cylinders internal leaks.	Consult your Dealer.
Stabilizers cylinders retract without control.	Non-return valves of cylinders defective operation.	Consult your Dealer.
	Cylinders internal leaks.	Consult your Dealer.
Blade cylinders extend or retract without control.	Non-return valves of cylinders defective operation.	Consult your Dealer.
	Cylinders internal leaks.	Consult your Dealer.
The blade lays only one side.	Non-return valves of cylinders defective operation.	Consult your Dealer.
	Cylinders internal leaks.	Consult your Dealer.
Stabilizer legs lay only on one side.	Non-return valves of cylinders defective operation.	Consult your Dealer.
	Cylinders internal leaks.	Consult your Dealer.



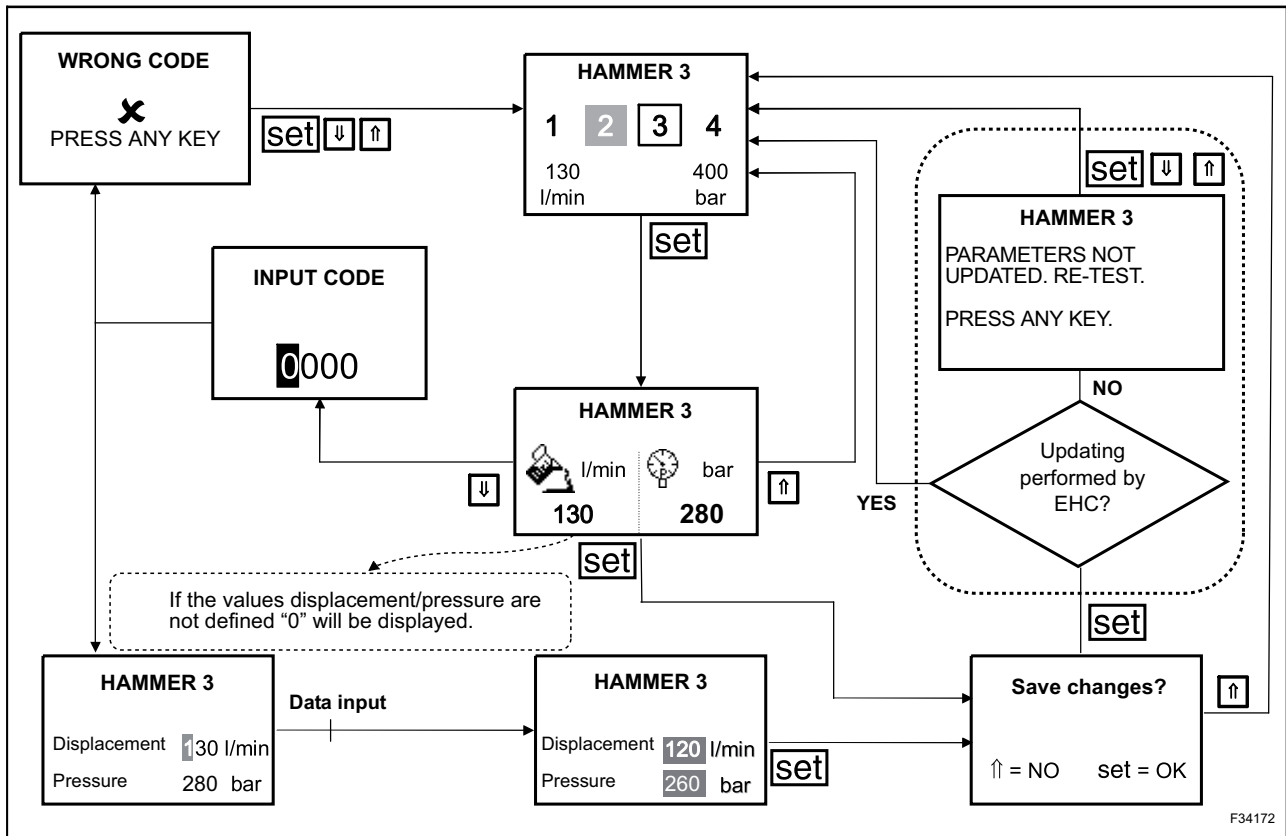

F34172

Depending on the working needs and conditions of use, up to four hydraulic oil pressure and volume flow configurations can be set for hydraulic hammers.

For the first configuration - hammer 1 - the machine is delivered ex factory with the following parameter settings:

volume flow 80 l/min (21.10 gal/min); pressure 160 bars (2320 psi).

For hammers 2 thru 4, the preset values for pressure and flow are in both cases 0.

**NOTE:** to use the hammer functions, the values specified by the hammer manufacturer must be adjusted as described below.

In the working mode, depress an arrow key until "MACHINE" appears in the lower part of the display and the machine symbol is marked by a frame. Confirm with "set" button.

Depress the arrow keys until the bar is on "HAMMER". Confirm with "set" button.

To get back to the "MACHINE" menu, depress the button with the upward arrow (↑) or downward arrow button (↓), until the beginning or the end of the display selection is reached.

When scrolling is continued on reaching the beginning or the end of the list, the program returns to the next higher menu.

The return to the next higher menu is automatic if

the buttons are not pressed for a prolonged period.

Confirm with "set" button, the sub-menu "HAMMER" is recalled.

The grey number field indicates actually active hammer 2 with the selected parameters for volume flow and pressure.

By means of the arrow buttons, you can set 4 different hammer settings: The selection is marked by a frame around the number.

In the example shown hammer 3 is preselected. Depress "set" to confirm the selection of hammer 3.

To activate the settings for hammer 3 without any changes, depress button "set". The following options are available:

- to reject selected hammer 3 with the newly selected values and to retain the settings of hammer 2. Depress the button with the upward arrow;
- to activate selected hammer 3 with unchanged settings. Depress the "set" button. The setting is saved.

**IDENTIFICATION PLATES**

When ordering spare parts or when needing information or assistance, it is always necessary to give the local Dealer all references as regards the type (4) and the serial number (1) of the relevant quick coupler.

This and other information (below) is reported on the plate (A) located on the quick coupler side.

1. Serial number
2. Weight
3. Operating pressure (400 bar)
4. Machine type
5. Serial number
6. Date of manufacture
7. Lifting force

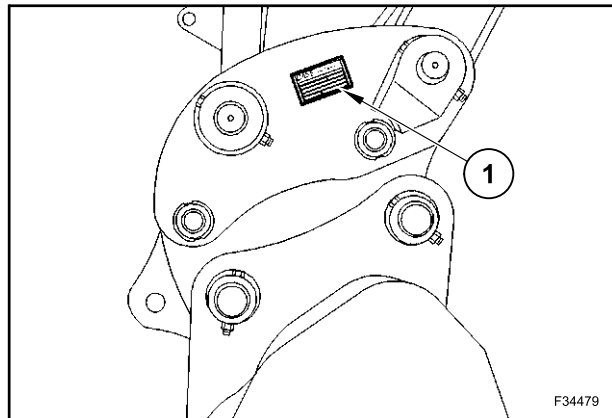

21

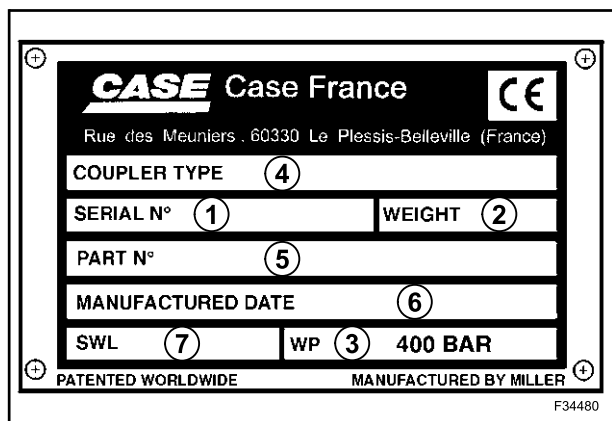

22

**CONTROL SWITCH**

On the control panel to the right of the cab seat, is installed switch (1) for quick coupler control.

Quick coupler activation (locking) by depressing blank face of switch (1).

Quick coupler deactivation (unlocking) by depressing symbol face of switch (1).

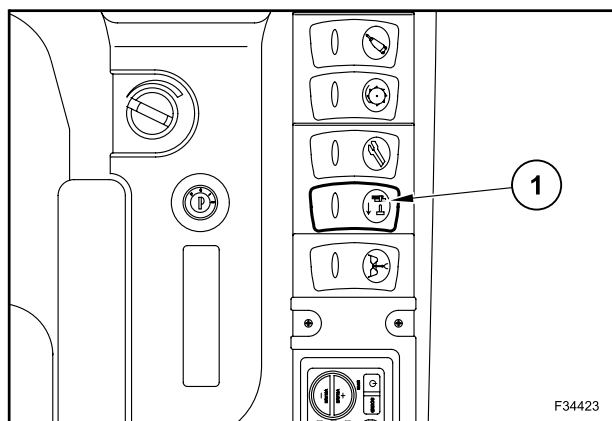

23

## USE OF THE ROTARY CUTTER

### BEFORE BEGINNING WORK

Check that the rotary cutter is securely locked with the working attachment and that the hydraulic lines are connected in the right way.

### SWITCHING ON THE ROTARY CUTTER

Preselect “Rotary cutter” with switch (1). Depress the blank face of switch, switch backlighting is on.

Once the function is set, the display shows for 10 seconds the menu for the selection of 4 different rotary cutters types. The rotary cutter can now be selected, e.g. 3 instead of 2 and/or the pertaining pressure and volume flow settings can be changed. To quit the menu before the 10-second interval has elapsed, depress one of the arrow buttons used for setting the machine power levels.

If the machine is to work alternately with the rotary cutter and with the hydraulic hammer, an electrically operated shuttle valve automatically connects the return-flow line of the rotary cutter with the hydraulic reservoir.

The rotary cutter can operate to power rating levels 4-7. The electronic power unit activates the power rating level that was active before engine shut off.

After returning to the main screen, the rotary cutter symbol is displayed. The number corresponding to selected cutter is visualized on the right upper corner (A).

Now the rotary cutter can be activated.

Pedal (2), is now controlling the “rotary cutter”.

Set the rotary cutter to working position, press pedal forward (2). The further the pedal is depressed, the higher the speed of the rotary cutter.

During work with the rotary, the pedal (2) can be temporarily switched over to the “Adjusting cylinder” function with push-button (3). The buzzer sounds a warning as long as the push-button is kept depressed.

### SWITCHING OFF THE ROTARY CUTTER

Release pedal (2).

Disconnect switch (1). Depress the symbol face of switch, switch backlighting is off.

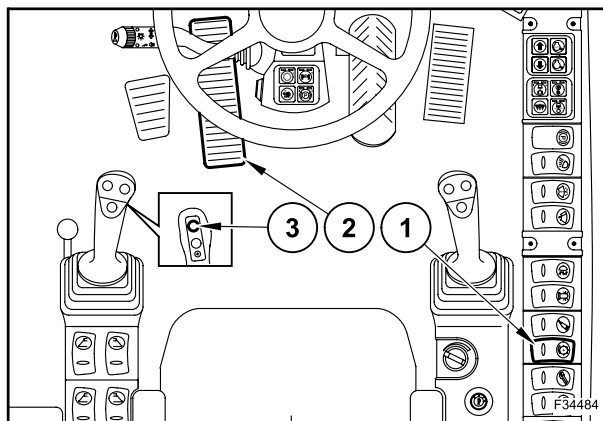

46

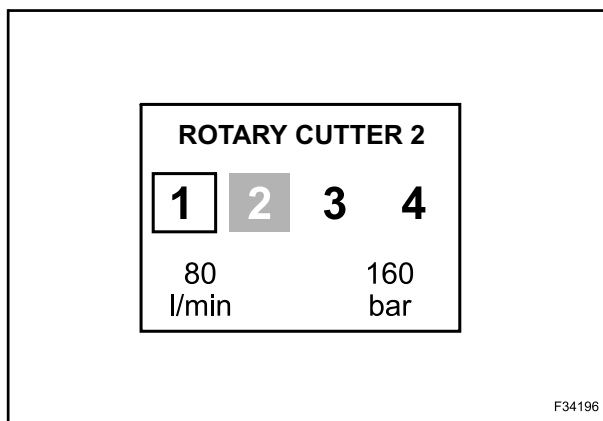

F34196

47

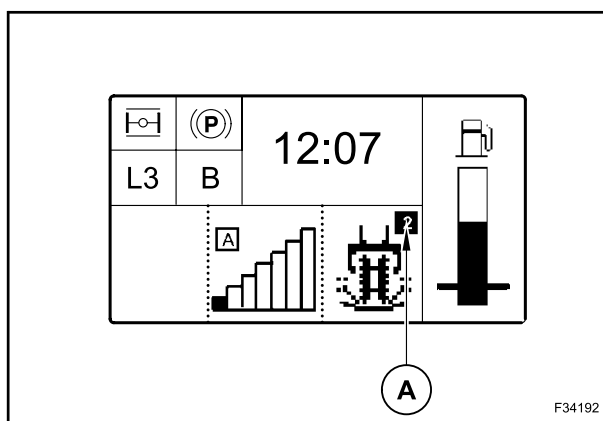

F34192

48

**OPERATION**

**⚠ WARNING ⚠**

When working with magnets for load lifting, all prescriptions and regulations regarding occupational safety and accident prevention must be strictly complied with. Furthermore, magnets for load lifting must be used only by operators perfectly familiar with the relevant instructions and safety regulations.

Before turning on power supply, the operator must check that the system of the 230 V line is in a visually perfect state. The operator must check that all connectors and fixed connections are correctly fastened and that the voltage limiting device of the magnet connection line operates as prescribed.

The magnet system is engaged by means of the switch.

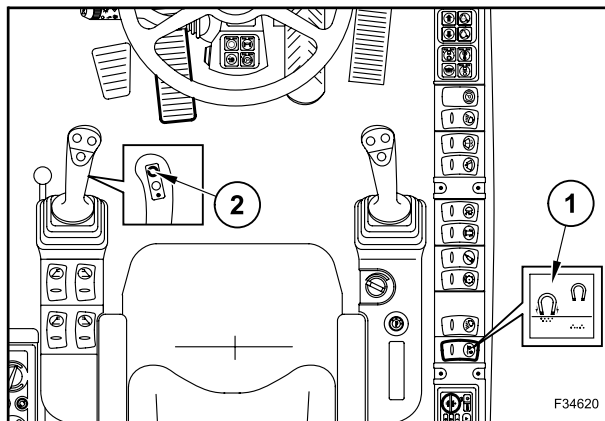

61

Once the system has been engaged, the system sets power level 4.

If a higher power level had been previously set, it remains unchanged. When all system components are ready for operation, the display of the machine shows the symbol of the magnet system (3). Furthermore, on the magnet display, located in the cab, the yellow "Ready for operation" lamp lights up (a).

The generator moves now to its working rpm range. This lamp stays on during operation and turns off only if a malfunction is signalled.

Engagement and disengagement of electric power supply, i.e. of the magnet for load lifting, is performed through the button (2) on the right hydraulic control lever.

When the engagement control is activated, the generator conveys the voltage to the magnet without contact. When the disengagement control is activated, the generator automatically starts demagnetization. During the demagnetization stage, which enables the magnet to disengage the load (about 1.5 seconds), no new engagement control may be activated. After 10 minutes of magnet operation, the system multi-function display also shows, time after time, the operation time reached by the magnet.

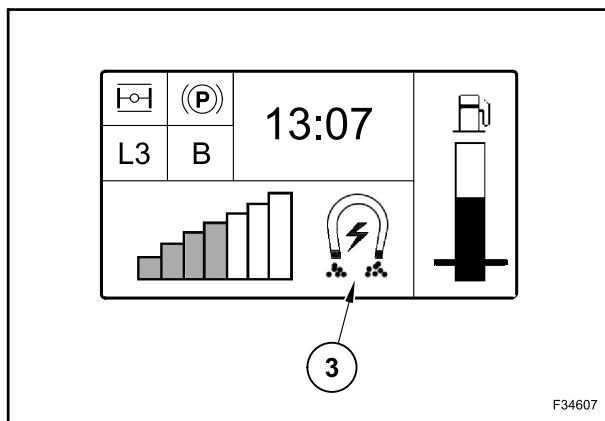

62

### BLADE PROTECTION

The blade can be equipped with a protection (1), installed frontally between the blade and the undercarriage, with the aim to protect the blade cylinders and relevant hydraulic pipes.

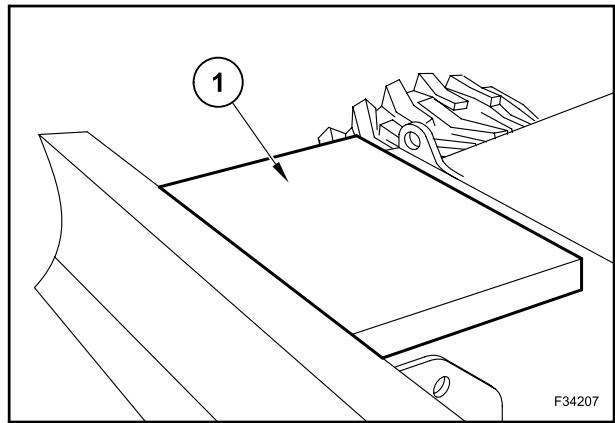

80

### TRANSPORT BRACKET FOR CLAMSHELL

A transport bracket (1) can be supplied for the clamshell transport, to fasten on the front side of the undercarriage. Secures the clamshell during travel or excavator transport.

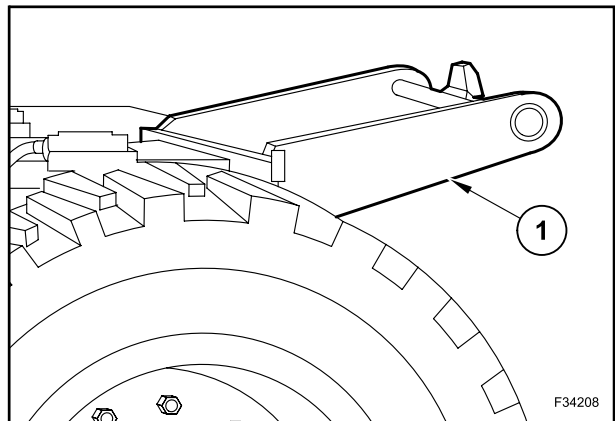

81

SECTION 8

OUTFIT WITH MONOBOOM

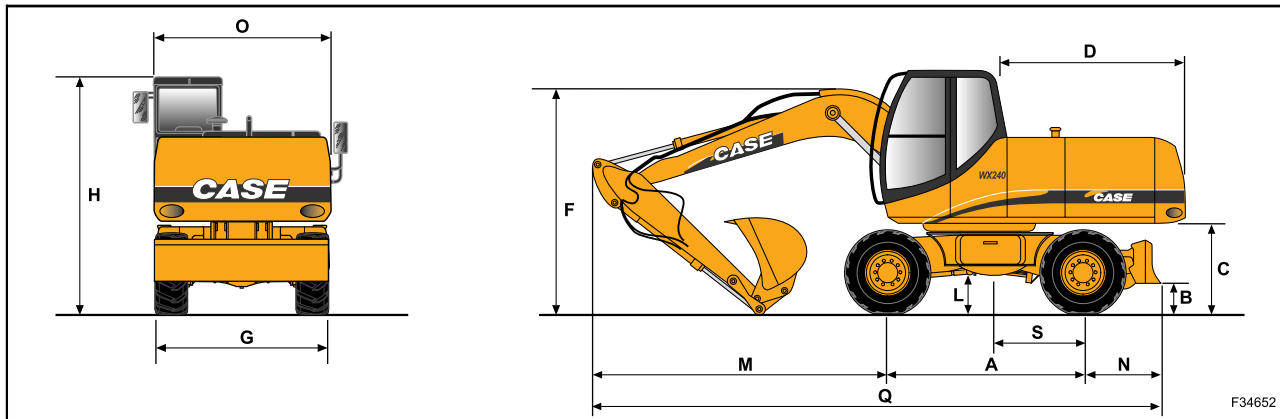

1

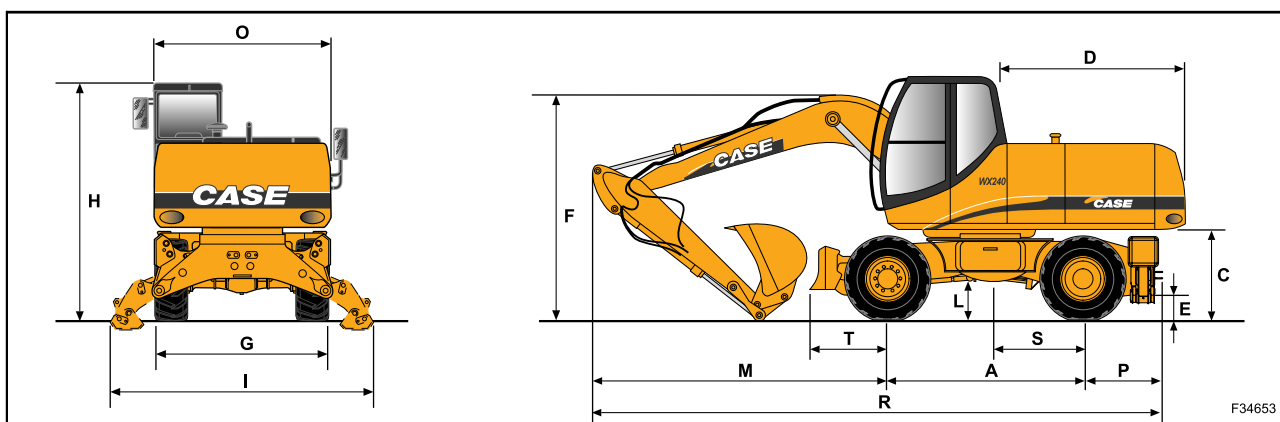

2

mm (in)

Dipper	A	B	C	D	E	F	G	H	I	L	M	N	O	P	Q	R	S	T
<b>2300</b> <b>(90.55)</b>	2750 (108.27)	430 (16.93)	1320 (51.97)	2750 (108.27)	370 (14.57)	3276 (128.98)	2520 (99.21)	3170 (124.80)	4260 (167.72)	345 (13.58)	5588 (220.00)	1000 (39.37)	2540 (100.00)	1020 (40.16)	9338 (367.64)	9358 (368.42)	1380 (54.33)	1000 (39.37)
<b>2600</b> <b>(102.36)</b>	2750 (108.27)	430 (16.93)	1320 (51.97)	2750 (108.27)	370 (14.57)	3206 (126.22)	2520 (99.21)	3170 (124.80)	4260 (167.72)	345 (13.58)	5565 (219.09)	1000 (39.37)	2540 (100.00)	1020 (40.16)	9315 (366.73)	9335 (367.52)	1380 (54.33)	1000 (39.37)
<b>2900</b> <b>(114.17)</b>	2750 (108.27)	430 (16.33)	1320 (51.97)	2750 (108.27)	370 (14.57)	3284 (129.29)	2520 (99.21)	3170 (124.80)	4260 (167.72)	345 (13.58)	5565 (219.09)	1000 (39.37)	2540 (100.00)	1020 (40.16)	9315 (366.73)	9335 (367.52)	1380 (54.33)	1000 (39.37)

G = tyres maximum width

O = machine maximum width

Dipper (mm) (in)	Rear blade (kg) (lb)	Rear stabilizers (kg) (lb)	Front blade and rear stabilizers (kg) (lb)	Front and rear stabilizers (kg) (lb)
2300 (90.55)	19980 (43956)	20650 (45430)	21330 (46926)	21740 (47828)
2600 (102.36)	20020 (44044)	20720 (45584)	21420 (47124)	21820 (48004)
2900 (114.17)	20120 (44264)	20820 (45804)	21520 (47344)	21920 (48224)

WX 240 MODELS

OUTFIT WITH PLACING BOOM

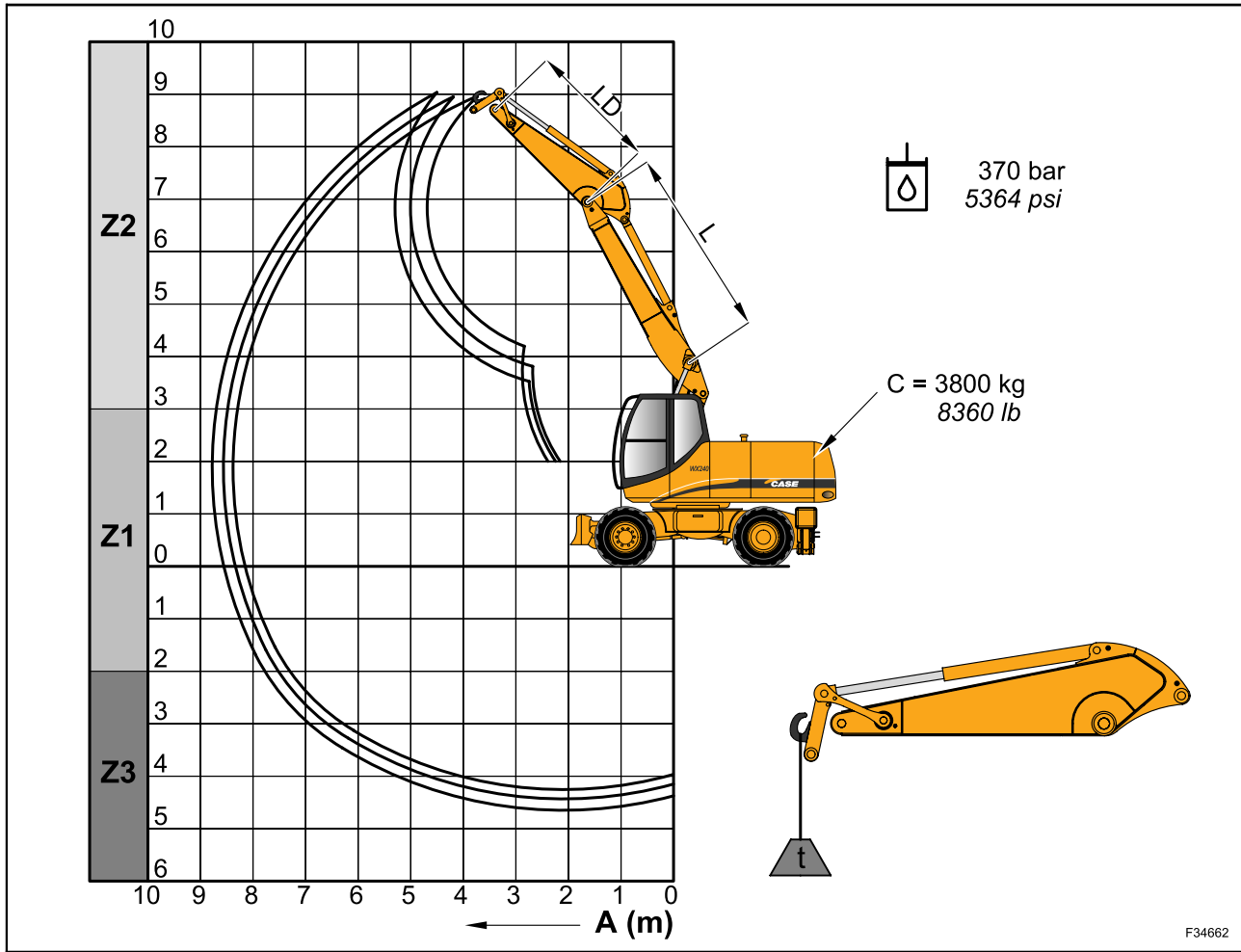

12

		360°																			
A (m) (ft)		3.0 (9.84)	4.5 (14.76)	6.0 (19.68)	7.5 (24.61)	3.0 (9.84)	4.5 (14.76)	6.0 (19.68)	7.5 (24.61)	3.0 (9.84)	4.5 (14.76)	6.0 (19.68)	7.5 (24.61)	3.0 (9.84)	4.5 (14.76)	6.0 (19.68)	7.5 (24.61)	3.0 (9.84)	4.5 (14.76)	6.0 (19.68)	7.5 (24.61)
LD = 2.3 m (7.55 ft)	Z2		6.4 (21.0)	4.2 (13.78)	2.7 (8.85)		7.0 (22.97)	5.2 (17.06)	3.5 (11.48)		7.0 (22.97)	6.4 (21.00)	4.6 (15.09)		7.0 (22.97)	6.4 (21.0)	5.6 (18.37)		5.7 (18.70)	3.8 (12.47)	2.5 (8.20)
	Z1	10.7 (35.10)	5.7 (18.70)	3.5 (11.48)	2.4 (7.87)	12.6 (41.34)	7.4 (24.28)	4.5 (14.76)	3.1 (10.17)	12.6 (41.34)	9.9 (32.48)	6.1 (20.01)	4.2 (13.78)	12.6 (41.34)	9.9 (32.48)	7.6 (24.93)	5.6 (18.37)	9.3 (30.51)	5.1 (16.73)	3.1 (10.17)	2.1 (6.89)
	Z3	10.3 (33.79)	5.2 (17.06)	3.3 (10.83)	0	14.2 (46.59)	6.9 (22.64)	4.3 (14.11)		21.5 (70.50)	9.5 (31.17)	5.9 (18.36)		22.8 (74.80)	12.9 (42.32)	7.9 (25.92)		9.0 (29.53)	4.6 (15.09)	2.9 (9.51)	
LD = 2.6 m (8.53 ft)	Z2	11.6 (38.06)	6.4 (21.00)	4.2 (13.78)	2.8 (9.19)	11.6 (38.06)	7.3 (23.95)	5.2 (17.06)	3.6 (11.81)	11.6 (38.06)	7.3 (23.95)	6.0 (19.68)	4.7 (15.42)	11.6 (38.06)	7.3 (23.95)	6.0 (19.58)	5.8 (19.03)	10.5 (34.45)	5.8 (19.03)	3.8 (12.47)	2.5 (8.20)
	Z1	10.7 (35.10)	5.7 (18.70)	3.5 (11.48)	2.3 (7.55)	12.5 (41.01)	7.4 (24.28)	4.5 (14.76)	3.0 (2.84)	12.5 (41.01)	9.5 (31.17)	6.1 (20.01)	4.1 (13.45)	12.5 (41.01)	9.5 (31.17)	7.4 (24.28)	5.4 (17.72)	9.3 (30.52)	5.1 (16.73)	3.1 (10.17)	2.0 (6.56)
	Z3	10.2 (33.46)	5.2 (17.06)	3.3 (10.83)	2.3 (7.55)	14.1 (46.26)	6.8 (22.31)	4.3 (14.11)	3.0 (9.84)	21.3 (69.88)	9.5 (31.17)	5.9 (19.36)	4.1 (13.45)	22.7 (74.47)	13.2 (43.31)	7.9 (25.92)	5.4 (17.72)	8.9 (29.20)	4.6 (15.09)	2.9 (9.51)	2.0 (6.56)
LD = 2.9 m (9.51 ft)	Z2	11.9 (38.04)	6.4 (21.00)	4.2 (13.78)	2.8 (9.19)	11.9 (38.04)	7.8 (25.59)	5.2 (17.06)	3.6 (11.81)	11.9 (39.04)	7.8 (25.59)	5.6 (18.37)	4.7 (15.42)	11.9 (39.04)	7.8 (25.59)	5.6 (18.37)	4.9 (16.08)	10.7 (35.10)	5.8 (19.03)	3.8 (12.47)	2.5 (8.20)
	Z1	10.7 (35.10)	5.7 (18.70)	3.6 (11.81)	2.3 (7.55)	11.9 (39.04)	7.4 (24.28)	4.6 (15.09)	3.0 (9.84)	11.9 (39.04)	9.1 (29.86)	6.2 (20.34)	4.1 (13.45)	11.9 (39.04)	9.1 (29.86)	7.0 (22.97)	5.5 (18.04)	9.3 (30.51)	5.1 (16.73)	3.2 (10.50)	2.0 (6.56)
	Z3	10.0 (32.81)	5.2 (17.05)	3.2 (10.50)	2.3 (7.55)	13.8 (45.27)	6.8 (22.31)	4.2 (13.78)	3.0 (9.84)	19.9 (65.29)	9.5 (31.17)	5.8 (19.03)	4.1 (13.45)	19.9 (65.29)	13.2 (43.31)	7.8 (25.59)	5.5 (18.04)	8.6 (28.21)	4.6 (15.9)	2.8 (9.19)	2.0 (6.56)

CLICK HERE TO **DOWNLOAD** THE COMPLETE MANUAL

- Thank you very much for reading the preview of the manual.
- You can download the complete manual from: [www.heydownloads.com](http://www.heydownloads.com) by clicking the link below



- Please note: If there is no response to CLICKING the link, please download this PDF first and then click on it.

CLICK HERE TO **DOWNLOAD** THE COMPLETE MANUAL