

ORIGINAL INSTRUCTIONS - according to Directive 2006/42/EC, Annex I 1.7.4.1

**1150M**  
**Stage IIIB**  
**Crawler Dozer**  
*PIN NGC105100 and above*

**OPERATOR'S MANUAL**

**Part number 48149735**

2<sup>nd</sup> edition English

May 2018

*Replaces part number 47983712*



CLICK HERE TO **DOWNLOAD** THE COMPLETE MANUAL

- Thank you very much for reading the preview of the manual.
- You can download the complete manual from: [www.heydownloads.com](http://www.heydownloads.com) by clicking the link below



- Please note: If there is no response to CLICKING the link, please download this PDF first and then click on it.

CLICK HERE TO **DOWNLOAD** THE COMPLETE MANUAL

## Electro-Magnetic Compatibility (EMC)

This machine complies strictly with the European Regulations on electro-magnetic emissions. However, interference may arise as a result of add-on equipment which may not necessarily meet the required standards. As such interference can result in serious malfunction of the unit and/or create unsafe situations, you must observe the following:

- Ensure that each piece of non- CASE CONSTRUCTION equipment fitted to the machine bears the CE mark.
- The maximum power of emission equipment (radio, telephones, etc.) must not exceed the limits imposed by the national authorities of the country where you use the machine.
- The electro-magnetic field generated by the add-on system should not exceed **24 V/m** at any time and at any location in the proximity of electronic components.

Failure to comply with these rules will render the CASE CONSTRUCTION warranty null and void.

## Selective Catalytic Reduction (SCR) exhaust treatment - Product overview

### What is Selective Catalytic Reduction (SCR)?

Your CASE CONSTRUCTION machine is equipped with additional components to comply with European exhaust emissions requirements. The main components of the SCR system include the SCR catalyst, the **DIESEL EXHAUST FLUID (DEF)/AdBLUE®** injection unit, the **DEF/AdBLUE®** tank, and the **DEF/AdBLUE®** dosing control unit.

### How does Selective Catalytic Reduction (SCR) work?

During combustion, harmful nitrogen oxide (NO<sub>x</sub>) molecules are formed in the exhaust. By injecting a **DEF/AdBLUE®** solution into the exhaust prior to a catalyst, the NO<sub>x</sub> can be converted to harmless elemental nitrogen and water. This happens when the NO<sub>x</sub> molecules react inside the catalyst with the heat generated by the engine and the ammonia in the **DEF/AdBLUE®** solution.

**NOTICE:** Do not idle the machine with no load for more than **6 h**, or damage to the SCR catalyst will occur.

During cold engine operation at low engine coolant and ambient air temperatures, water vapor will be visible from the exhaust. This water vapor will resemble steam or light white smoke, and will dissipate as the engine and machine components warm. This water vapor is considered normal.

**NOTE:** After engine shutdown, the SCR system will perform a purge cycle, which permits the supply module to continue to run for up to 70 seconds. This is considered normal and requires no action from the operator.

### What is DIESEL EXHAUST FLUID (DEF)/AdBLUE®?

**DEF/AdBLUE®** is a clear, colorless, non-toxic, aqueous urea solution ( **32.5%**) with a slight ammonia odor. It is used to chemically reduce NO<sub>x</sub> emissions from heavy-duty diesel-powered vehicles. **DEF/AdBLUE®** is neither explosive nor harmful to the environment. **DEF/AdBLUE®** is classified under the minimum-risk category of transportable fluids.

International standard **ISO 22241-1** defines **DEF/AdBLUE®** quality. The American Petroleum Institute (API®) has a voluntary certification program for **DEF/AdBLUE®**. To ensure **DEF/AdBLUE®** satisfies the requirements of ISO 22241, look for the API® DEF Certification Mark™ whenever you purchase **DEF/AdBLUE®**.

## **Operator protective structure**

Your machine is equipped with an operator protective structure, such as: a Roll Over Protective Structure (ROPS), Falling Objects Protective Structure (FOPS), or a cab with a ROPS. A ROPS may be a can frame or a two-posted or four-posted structure used for the protection of the operator to minimize the possibility of serious injury. The mounting structure and fasteners forming the mounting connection with the machine are part of the ROPS.

The protective structure is a special safety component of your machine.

DO NOT attach any device to the protective structure for pulling purposes. DO NOT drill holes to the protective structure.

The protective structure and interconnecting components are a certified system. Any damage, fire, corrosion, or modification will weaken the structure and reduce your protection. If this occurs, THE PROTECTIVE STRUCTURE MUST BE REPLACED so that it will provide the same protection as a new protective structure. Contact your dealer for protective structure inspection and replacement.

After an accident, fire, tip over, or roll over, the following MUST be performed by a qualified technician before returning the machine to field or job-site operations:

- The protective structure MUST BE REPLACED.
- The mounting or suspension for the protective structure, operator's seat and suspension, seat belts and mounting components, and wiring within the operator's protective system MUST be carefully inspected for damage.
- All damaged parts MUST BE REPLACED.

DO NOT WELD, DRILL HOLES, ATTEMPT TO STRAIGHTEN, OR REPAIR THE PROTECTIVE STRUCTURE. MODIFICATION IN ANY WAY CAN REDUCE THE STRUCTURAL INTEGRITY OF THE STRUCTURE, WHICH COULD CAUSE DEATH OR SERIOUS INJURY IN THE EVENT OF FIRE, TIP OVER, ROLL OVER, COLLISION, OR ACCIDENT.

Seat belts are part of your protective system and must be worn at all times. The operator must be held to the seat inside the frame in order for the protective system to work.

## **Air-conditioning system**

The air-conditioning system is under high pressure. Do not disconnect any lines. The release of high pressure can cause serious injury.

The air-conditioning system contains gases that are harmful to the environment when released into the atmosphere. Do not attempt to service or repair the system.

Only trained service technicians can service, repair, or recharge the air-conditioning system.

## **Backup alarm system**

Do not disconnect backup alarm system if so equipped.

## **Personal Protective Equipment (PPE)**

Wear Personal Protective Equipment (PPE) such as hard hat, eye protection, heavy gloves, hearing protection, protective clothing, etc.

## **Do Not Operate tag**

Before you start servicing the machine, attach a 'Do Not Operate' warning tag to the machine in an area that will be visible.

**WARNING — Use your seat belt**

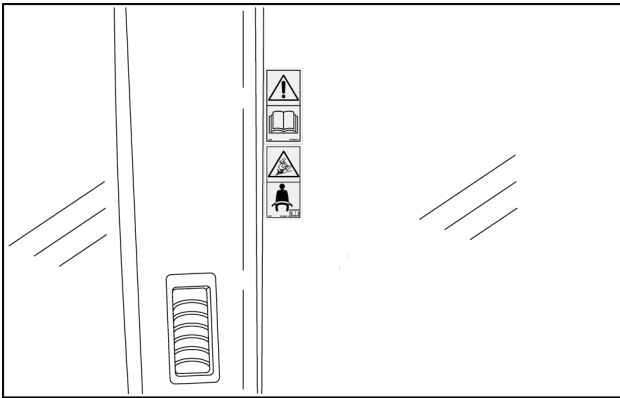

This WARNING safety sign is located inside the operator's compartment on the right-hand side.  
**WARNING — Avoid crushing. Do not jump if machine tips. Use seat belt. Failure to comply with this warning could result in death or serious injury.**  
ISO safety sign number: 87706391



87706391\_B 2

**WARNING — Read the operator's manual**

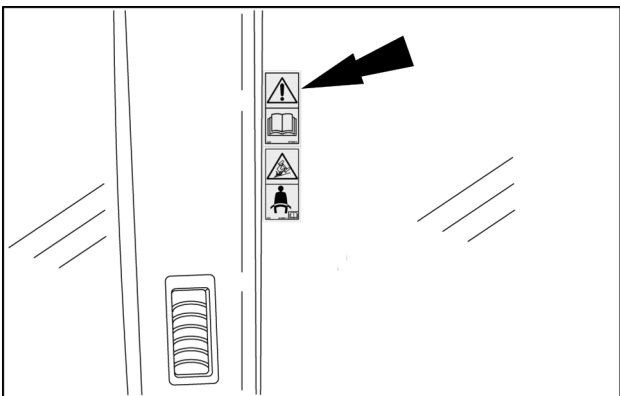

This WARNING safety sign is located inside the operator's compartment.  
**WARNING — Read the Operator's Manual. Fasten seat belt. No riders. Keep others away. Failure to comply with this warning could result in death or serious injury.**  
ISO safety sign number: 87706389

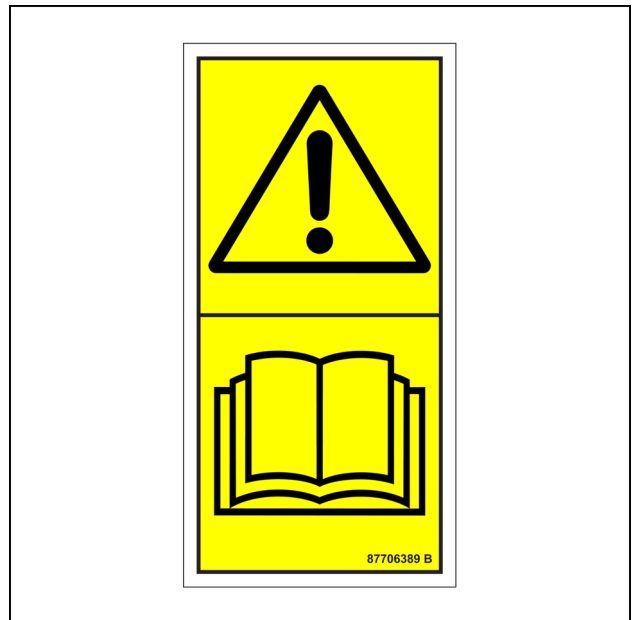

87706389\_B 4

### Hydraulic oil fill location

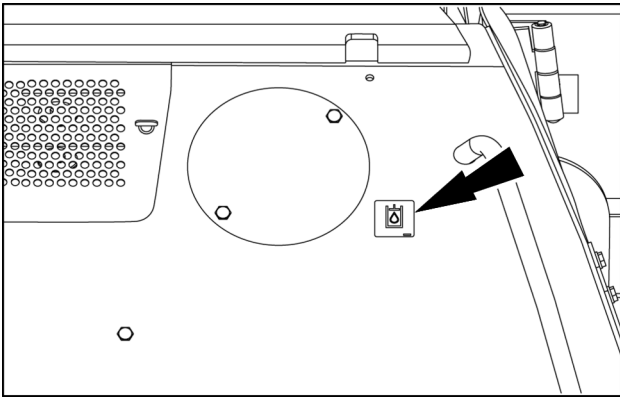

RAIL16DOZ0635BA 41

This informational sign is located next to the hydraulic oil fill. It indicates the correct hydraulic oil fill location. ISO sign number: 87726702

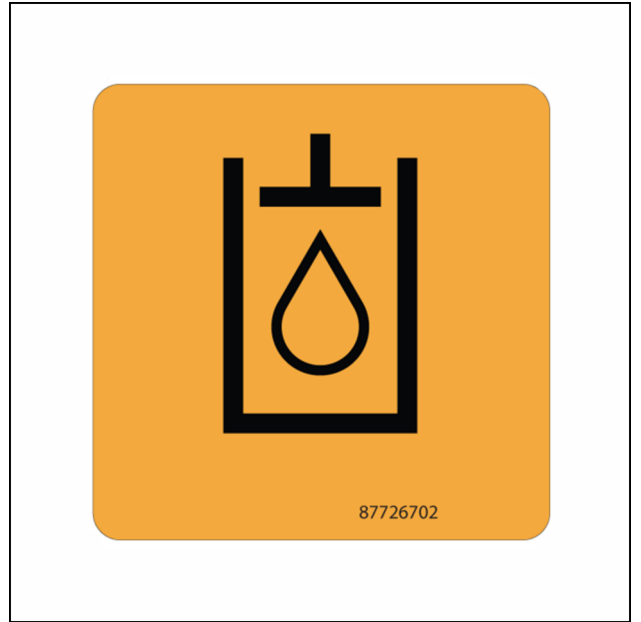

87726702 42

## Foot controls

### Dual function pedal

The dual function pedal can be switched to operate as a deceleration pedal or a transmission control pedal. As a deceleration pedal, the engine RPM is reduced as the pedal is depressed. As a transmission pedal, the hydraulic system is de-stroked as the pedal is depressed. The transmission pedal is the default function. These settings are made through the transmission selection on the multi-function display.

**NOTE:** See the multi-function display on page 4-14 for more information.

### Transmission pedal

As a transmission pedal, the machine varies the transmission flow (pump/motor displacement) allowing for inching. Pushing the pedal completely down will de-stroke the hydraulics.

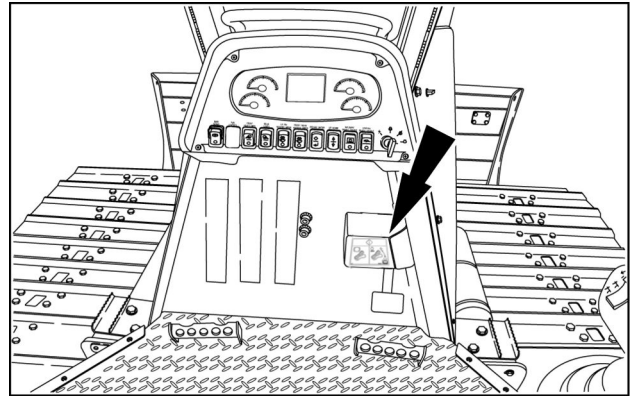

RAIL13DOZ1616AA 1

### Deceleration pedal

The deceleration pedal reduces the engine RPM and slows the machine. Push the deceleration pedal to slow or stop the machine.

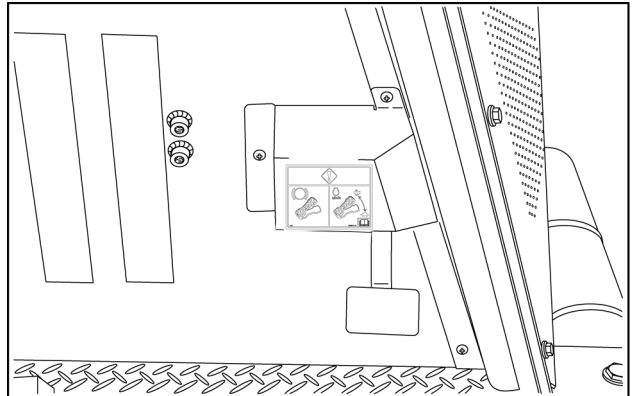

RAIL12DOZ1254AA 2

Use the deceleration pedal to reduce the speed all the way to zero by de-stroking the ground drive along with decreasing the engine RPM.

**NOTE:** Use the deceleration pedal to control the dozer for precision work.

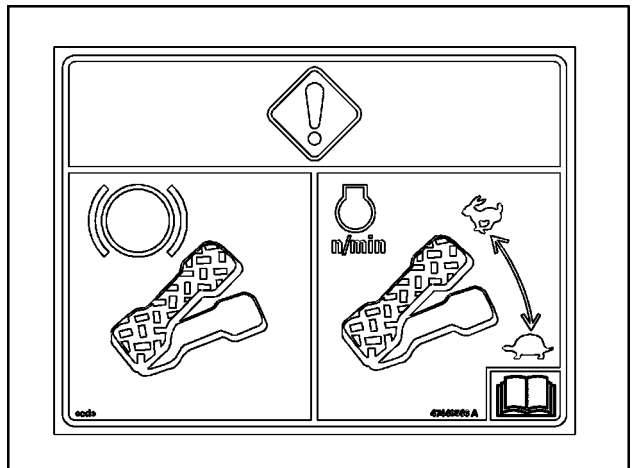

47449566 3

### 3. Voltage gauge

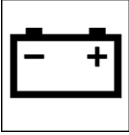

The voltage gauge indicates the voltage in the operating system. The gauge indicates if the battery is properly charging. If the gauge moves into the yellow zone, the engine should be monitored. If the gauge moves into the red zone the battery is in a discharge condition. If the warning light illuminates and the gauge moves into the red zone, stop the machine and correct the problem.

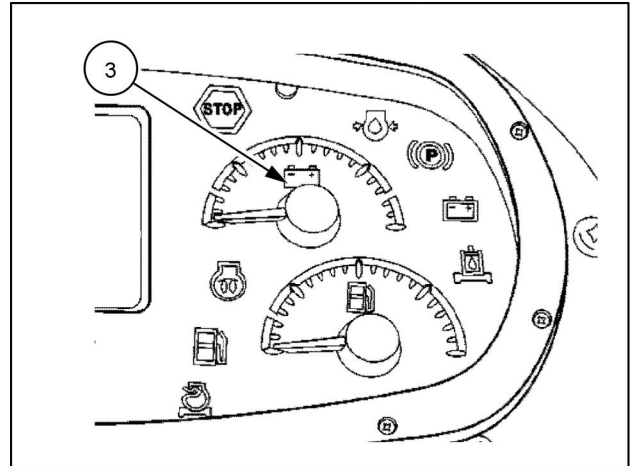

RAIL12DOZ0821AA 6

**NOTICE:** Do not operate the machine if the indicator turns red and the alarm sounds continuously. Stop the machine and correct the problem.

## LEFT-HAND SIDE CONTROLS

### Control levers

#### **▲ DANGER**

**Hazard to bystanders!**

**ALWAYS** make sure the work area is clear of bystanders and domestic animals before starting this procedure. Know the full area of movement of the machine. Do not permit anyone to enter the area of movement during this procedure.

Failure to comply will result in death or serious injury.

D0164A

#### Horn button

The direction control lever allows for directional movement of the machine. The horn button is also located on the direction control lever. Always sound the horn before starting the machine.

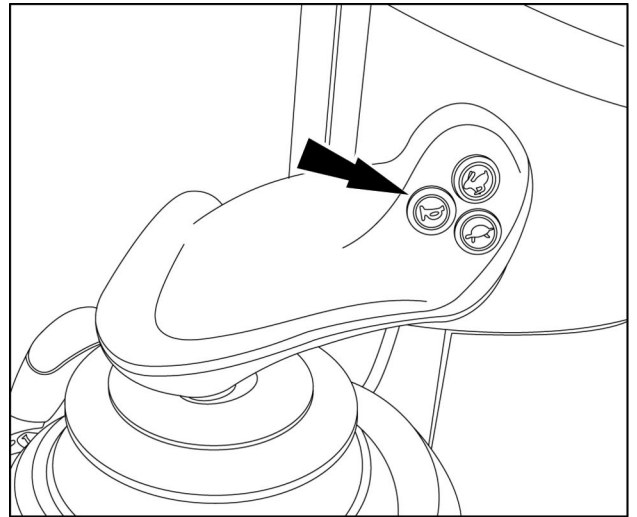

RAIL12DOZ0181AA 1

#### Direction control lever

The direction control lever allows forward, reverse, neutral direction, turning and counter rotation.

Depending on the machine configuration, the lever will have a neutral detent position and a proportional forward and reverse action, or the lever will have a detent for neutral, forward and reverse positions.

Turning is also controlled by the direction control lever. The direction control lever has a feel point for left and right counter rotation.

Use the machine in a clear, unobstructed area until you become familiar with the controls. See page 4-9 for additional information on operating the machine.

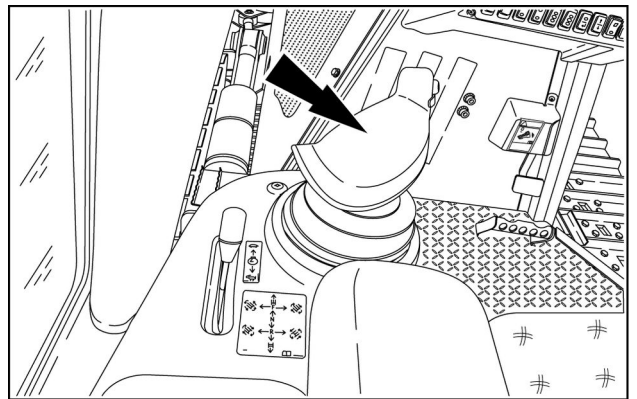

RAPH12DOZ0080AA 2

#### Proportional position control configuration

When the lever has a neutral detent position and a proportional forward and reverse action, the lever remains in the forward or reverse position until it is moved by the operator.

#### Detent position control configuration

When the lever has detent positions for neutral, forward, and reverse positions, the lever remains in the forward or reverse position until it is moved by the operator from either detent position.

## EXTERIOR CONTROLS

### Master disconnect switch

The master electrical disconnect switch is located on the left side of the machine. The switch has two positions: ON and OFF.

#### Master electrical switch ON



The master disconnect switch in the ON position energizes the entire electrical system.

#### Master electrical switch OFF

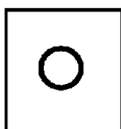

All machine power is interrupted in the OFF position.

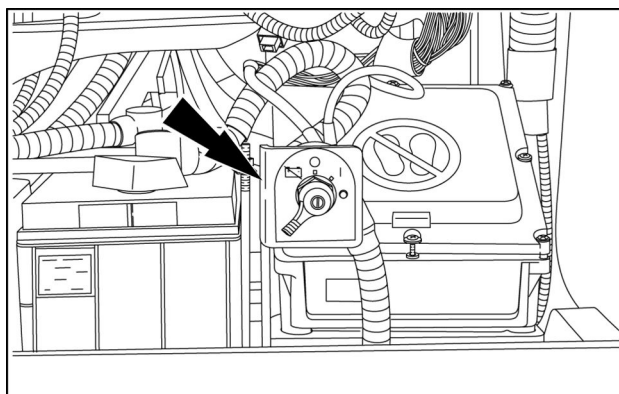

RAPH12DOZ0044AA 1

**NOTICE:** DO NOT use the master electrical disconnect switch to stop the engine.

**NOTE:** After engine shutdown, the SCR system will perform a purge cycle which permits the supply module to continue to run. Do not shut off the master disconnect for 70 seconds after key off.

## Operator preferences

### Escaping from errors

When using the machine computer system, you can return to the main menu by pressing the escape switch. When setting desired selections, should an error message display, press the escape switch and begin again.

**NOTE:** *Selecting options and navigating through the screen menus are the same for all functions. The display will tell the operator if errors have occurred.*

### Language screen, measurement units and clock

The LCD screen can be set with language, measurements, and/or clock preferences. Use the arrow switch to scroll to the preferences menu. Press the enter/confirm switch on the correct selection. Press the escape switch to return to the main driving screen, and lock the selection into memory.

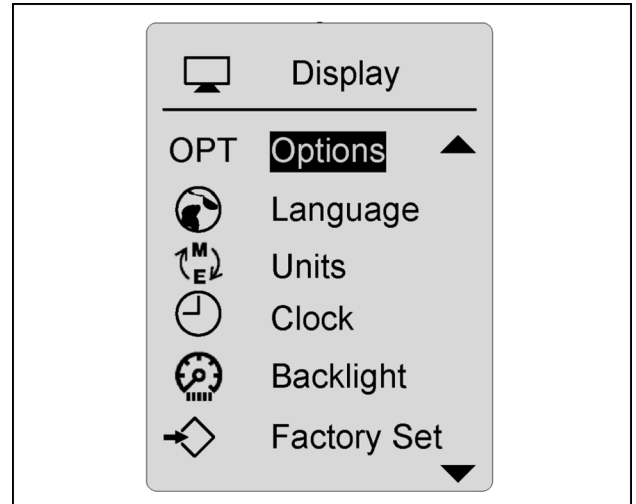

RCPH10WHL358BAH 1

### Languages

Choose the preferences desired: language in English, Spanish, Portuguese, Italian, German, French; measurement units in metric, English, or Imperial; and clock units in 12 or 24 hour cycles. Highlight the preference you wish to change, and press the enter/confirm switch. The preference will flash and allow you to scroll through the choices. When the correct preference is chosen, press the enter/confirm switch, then use the escape switch to return to the main driving screen in order to lock the preference into memory.



RAIL17DOZ0462AA 2

## Cold temperature starting aids

### **⚠ WARNING**

**Explosion hazard!**

**DO NOT use ether starting fluid. Serious engine damage, explosion, death, or serious personal injury could occur.**

**Failure to comply could result in death or serious injury.**

W0148A

This machine may be equipped with an engine grid heater. Turn the key switch to ON, and wait for the engine grid heater indicator lamp to go out. The indicator light may come on again during cranking and shortly after the engine starts for post heating. This allows for smooth running conditions during cold weather warm up. Contact your authorized dealer for additional cold weather starting aids.

### **Machine warm up**

To properly warm the machine in cold conditions:

1. Set engine speed to **1200 – 1400 RPM**. Operate the ground drive at no greater than speed 8.
2. Cycle the implement system functions by moving each function the full cylinder stroke several times.
3. Repeat Step 2 for **10 min** or until hydraulic oil temperature is at least **10.0 °C (50.0 °F)**.
4. Once the engine has started, run the engine at about half throttle ( **1650 RPM**) for a minimum of four minutes under no load. This will help stabilize the engine.
5. Operate the machine in a clear safe area. Check the full operation of the machine.

**NOTE:** Warm oil to above **20.0 °C (68.0 °F)** for optimized performance.

If the machine idles in cold temperatures, the engine will stay warm, but the hydraulic oil and brake oil will cool. The oil and components can become cold, which will affect hydraulic function response time. If this should happen you **MUST** go through the complete warm up procedure.

Make sure the track system is clean when you park the machine. In cold weather, park the machine on planks. This will prevent the tracks from freezing to the ground.

**NOTICE:** If the track freezes to the ground, do not try to drive the machine. This will cause damage to the power train.

### Auto park brake setting

To adjust the auto park brake setting, follow the same steps as for steering sensitivity, then highlight "AutoPrk-Brk".

The AutoPrkBrk choices are:

- On (default)
- Off

After selecting and highlighting the desired value, press the enter switch to confirm the selection. Press the escape switch to store the choice.

When the AutoPrkBrk function is set to "ON", the unit is in neutral and the UCM senses movement from the drive motor speed sensors for **30 s**, the park brake will engage.

### Factory Set

This setting allows the reset of functions to factory default. Follow the prompts, and press the enter switch to confirm the selection.



RAIL12DOZ0217AA 5

4. Use an Allen wrench, and turn the engagement screw **(4)** counterclockwise two turns on each relief valve.

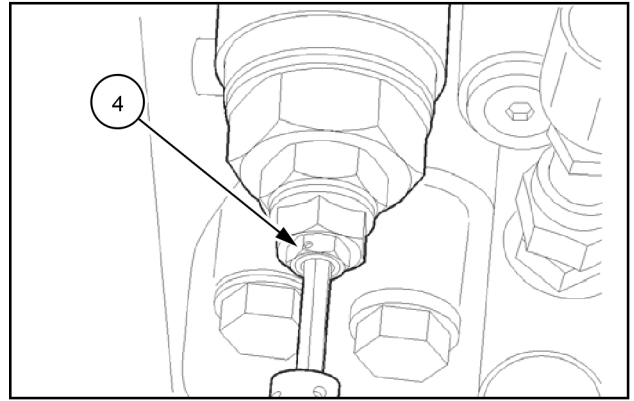

RCIL10CWL116AAL 5

## Releasing the brakes

This machine is equipped with SAHR (spring applied hydraulically released) parking brakes. Hydraulic pressure must release the brakes. If the engine will not run, you **MUST** use a hand pump to release the brakes.

1. Remove the hydraulic reservoir breather.

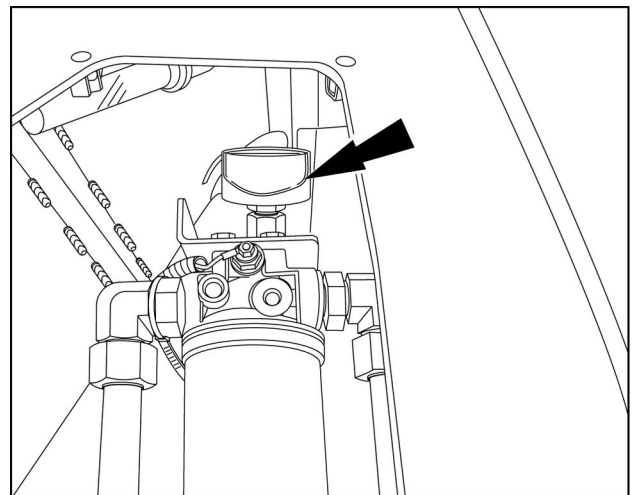

RAIL12DOZ0372AA 6

2. Connect a vacuum pump at the hydraulic reservoir breather, and hold a vacuum to keep from losing fluid.
3. Disconnect the fittings **(1)** at the brake lines and cap the fittings. There are two brake lines. A T-fitting will be required for the two lines in order to connect to the hand pump. If a T-fitting is not available, two pumps must be used.

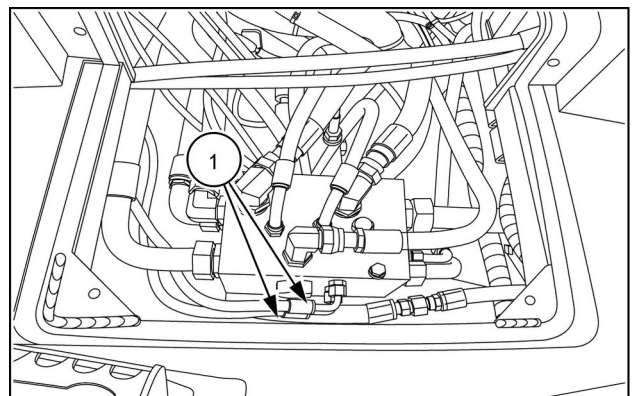

RAPH12DOZ0094AA 7

## Dozer blade pitch adjustment (if equipped)

### Dozer blade pitch adjustment

1. Raise the dozer blade **100 mm (3.9 in)**.
2. Release the dozer blade control lever, and set the parking brake.
3. Shut the engine off, and remove the ignition key.
4. Loosen the retaining bolt **(1)** from the slotted keyway on the strut.
5. Use a bar **(2)** to adjust the strut clockwise or counter-clockwise until the desired pitch angle is reached, stopping at 1/2-turn increments.
6. Replace the retaining bolt **(1)** at the slotted keyway.

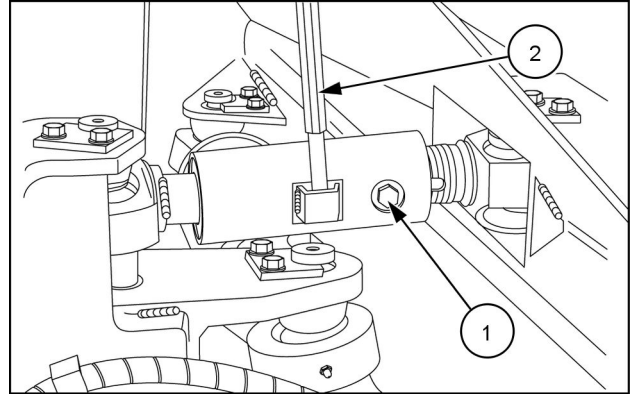

RAIL14DOZ0567AA 1

### Rearward position blade pitched rearward

When the top of the dozer blade pitch is set to the rearward position, the blade will be able to push a larger load. The blade will stay on top in soft ground. The blade will not dig into the ground. Use the rearward pitch position for fine grading.

### Forward position blade pitched forward

When the top of the dozer blade pitch is set to the forward position, the load slides off of blade as crawler travels in reverse. The blade will dig into hard ground. There will be less load spillage over the top of the blade.

CLICK HERE TO **DOWNLOAD** THE COMPLETE MANUAL

- Thank you very much for reading the preview of the manual.
- You can download the complete manual from: [www.heydownloads.com](http://www.heydownloads.com) by clicking the link below



- Please note: If there is no response to CLICKING the link, please download this PDF first and then click on it.

CLICK HERE TO **DOWNLOAD** THE COMPLETE MANUAL

### Clean rollers

Use a hose or pressure washer to clean the track frame rollers (1) and carrier rollers (2).

**NOTICE:** Avoid direct contact to the track roller rubber plugs with the use high pressure washers. This may result in damage to or loss of the rubber plugs.

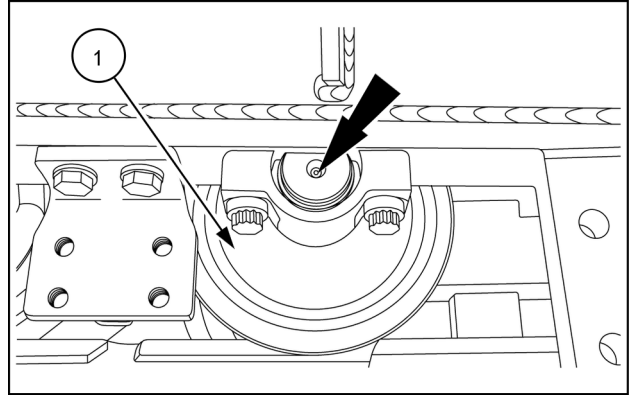

RAIL16DOZ0223AA 7

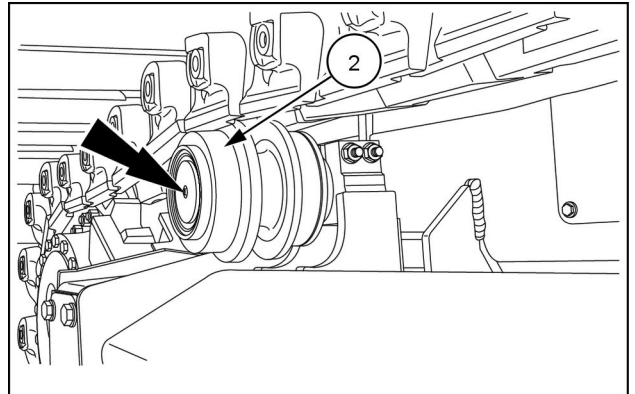

RAIL16DOZ0208AA 8

### Clean tracks

Use a hose or pressure washer to clean the track chains and track pads (1).

**NOTICE:** Avoid direct contact to the track chain rubber plugs with the use high pressure washers. This may result in damage to or loss of the rubber plugs.

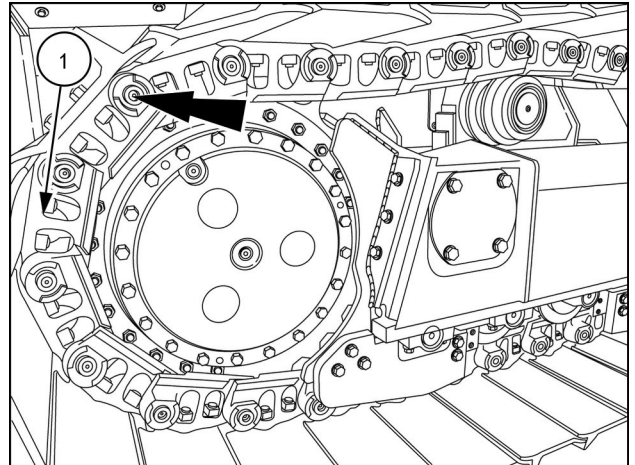

RAIL16DOZ0025AA 9

**NOTICE:** When the tracks are unsupported off of the ground, do not run the machine at speeds above the step 8 position. This may result in damage to the drivetrain components.

## Cab floor and seat access

Keep all unauthorized personnel clear of the area. Park the machine on level ground, in neutral with the parking brake applied, and the attachment lowered to the ground. Make sure that all residual pressure is relieved from circuits before beginning maintenance.

Hoses and components that do not require routine operator maintenance are located beneath the cab floor and seat. If necessary, you can access these components as follows:

1. Remove the floor mat along both door thresholds.
2. Lift the mat over the foot pedals and remove the mat from the cab.

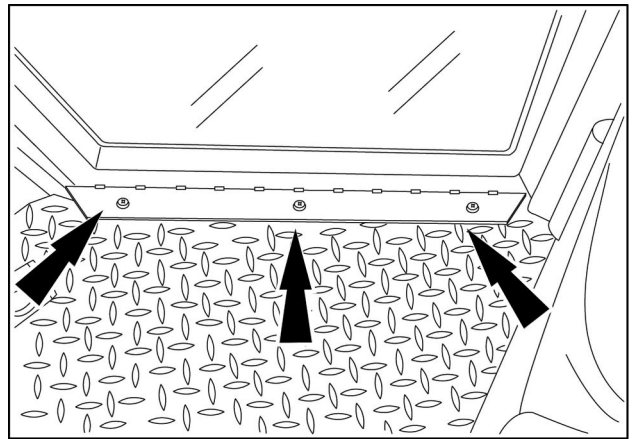

RAIL12DOZ0232AA 1

3. Slide the operator's seat all the way forward.
4. Tilt the operator seat back down.
5. Remove the armrests to prevent obstruction.

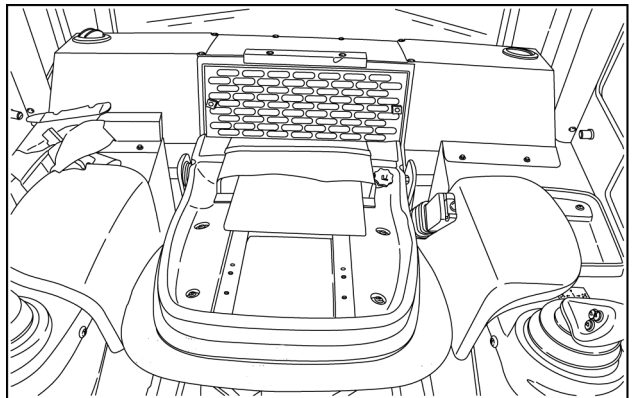

RAPH12DOZ0074AA 2

6. Remove the bolts from the floor cover plate, and remove the cover plate. This will allow access to valves and hoses beneath the cab.

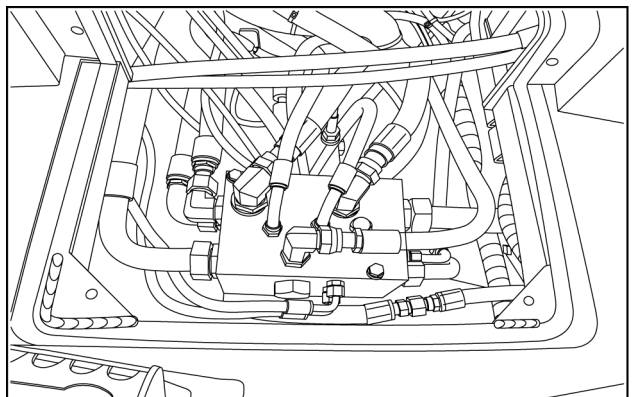

RAPH12DOZ0094AA 3

## General specification - Biodiesel fuels - Biodiesel fuels

### Biodiesel fuel usage in CASE CONSTRUCTION products

#### Introduction to biodiesel fuel

Fatty Acid Methyl Ester (FAME) biodiesel fuel, called biodiesel fuel in the following paragraphs, consists of a family of fuels derived from vegetable oils that producers treat with methyl esters.

There are two main biodiesel fuel types: Rapeseed Methyl Ester (RME) and Soybean Methyl Ester (SME). RME is a blend of rapeseed and sunflower methyl ester. RME is the preferred crop in Europe. SME is the preferred crop in the United States.

Biodiesel fuel is a renewable alternative fuel source. Its use and development is promoted worldwide, especially in Europe and in the United States.

**NOTICE:** *It is imperative that you check with your CASE CONSTRUCTION dealer to learn which biodiesel fuel blend CASE CONSTRUCTION approves for use in your engine. Be aware that the use of biodiesel fuel blends that do not comply with EN14214, or DIN V 51606 could cause severe damage to the engine and fuel system of your machine. The use of non-approved biodiesel fuel blends may void CASE CONSTRUCTION Warranty coverage.*

Biodiesel fuel blends use the following labels to indicate the percentage of biodiesel fuel in the blend:

- B5: indicates the blend of **5%** biodiesel fuel and **95%** diesel fuel.
- B7: indicates the blend of **7%** biodiesel fuel and **93%** diesel fuel.
- B20: indicates the blend of **20%** biodiesel fuel and **80%** diesel fuel.
- B100: indicates **100%** biodiesel fuel.

Biodiesel fuel has several positive features in comparison with diesel fuel:

- Biodiesel fuel adds lubricity to the fuel. Additional lubricity is beneficial in many circumstances, particularly as fuels contain less sulfur and aromatics.
- Biodiesel fuel has a greater cetane number and burns more cleanly.
- Biodiesel fuel produces less particulate matter and reduces smoke emissions.
- Biodiesel fuel is fully biodegradable and non-toxic.

### Specifications for diesel fuel and biodiesel fuel

The following standards apply to diesel fuel specifications:

- **EN 590** -Automotive fuels - Diesel - Requirements and test methods. ( **10 ppm** sulfur maximum.)

The following standards apply to biodiesel fuel blends:

- European Diesel Fuel Specification **EN 590** allows up to **7%** biodiesel since 2009. European fuel suppliers are allowed to use up to **7%** biodiesel fuel (B7) to supply the network.

The following standards apply to pure biodiesel fuel (B100):

- **EN14214** - Liquid petroleum products - Fatty acid methyl esters (FAME) for use in diesel engines and heating applications - Requirements and test methods
- **DIN V 51606** - German standard for biodiesel.

Before producers can convert raw oil into usable biodiesel fuel, it must undergo transesterification to remove glycerides. During the transesterification process, the oil reacts with an alcohol to separate the glycerin from the fat or vegetable oil. This process leaves behind two products: methyl ester (the chemical name for biodiesel) and glycerin (a byproduct usually sold for use in soaps or other products).

**NOTICE:** *CASE CONSTRUCTION only approves transesterified biodiesel fuel blends that comply with EN14214 or the German standard DIN V 51606.*

**NOTICE:** *Non-transesterified fuels made from rapeseed oil or similar high oil content crops include cold-pressed biodiesel, cold-pressed oil, Straight Vegetable Oil (SVO), or more generally unrefined vegetable oils used as motor fuel. Because these types of fuel are not transesterified, they do not fulfil the requirements of EN14214. There is no recognized quality standard available for these types of fuel; therefore, CASE CONSTRUCTION DOES NOT APPROVE the use of cold-pressed biodiesel, cold-pressed oil, Straight Vegetable Oil (SVO), or more generally unrefined vegetable oils as motor fuel at any blend in any CASE CONSTRUCTION product.*

**NOTICE:** *CASE CONSTRUCTION will discontinue Warranty coverage of any engine equipment and fuel injection equipment you fit to a CASE CONSTRUCTION machine that is found to have run with blend of NON-APPROVED fuel (fuel that does not fulfill the requirements of EN14214).*

### Biodiesel fuel usage conditions

You must stringently follow the biodiesel fuel usage conditions. Incorrect application of the biodiesel fuel usage conditions could lead to severe damage to the engine and fuel injection equipment and aftertreatment system.

The main concerns about operation of equipment with biodiesel fuels are:

- Filter and injector blockage caused by poor fuel quality

## Daily inspection

### General

#### **▲ WARNING**

Improper operation or service of this machine can result in an accident. Read and understand the **SAFETY INFORMATION** Section before you perform any maintenance, service, or repairs. Read and understand the specific service procedures for the components you plan to work with before you start servicing the machine. Failure to comply could result in death or serious injury.

W0138A

Inspect the machine and service certain of its components every day, before starting work.

### General

- Check for water or oil leaks.
- Check that all screws and nuts are correctly tightened.
- Wipe off any dust and clean off any accumulated debris (engine, operator's compartment, etc.).
- Check track for tension and pack.
- Check for damage.

### Engine

- Turn engine off and remove ignition key.
- Remove any debris from around the engine, hot components, or rotating equipment.
- Check the oil level, and change the oil, if necessary.
- Check the coolant level at overflow tank.
- Check for clogging or damage to the radiator.
- Check the engine accessory drive belt condition.
- Check that air filter restriction warning is not illuminated on console cluster.
- Check for water or oil leaks on the components.
- Check the condition of all lines.
- Check the fuel tank level.

**Remote grease zerks**

Left side

- (1) Left lift cylinder
- (2) C-frame
- (3) Equalizer beam

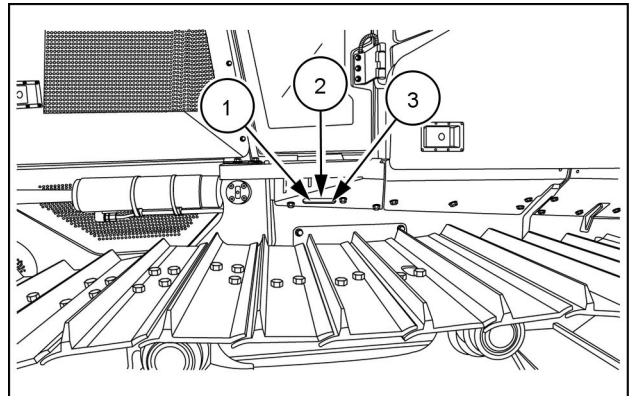

RAIL16DOZ0194AA 1

Right side

- (4) C-frame
- (5) Lift cylinder

**Grease zerks**

Equalizer beam (1) — one on either side of the track-frame

Pivot shaft (2) — one on either side of the trackframe

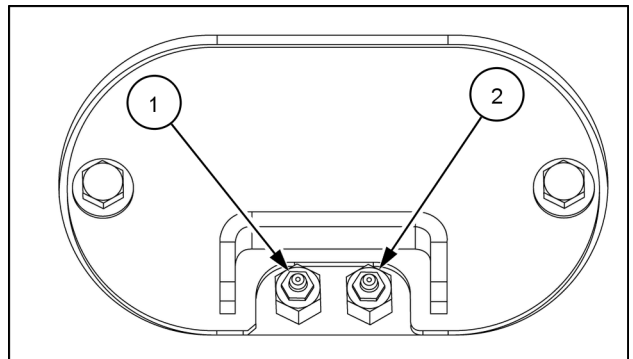

RAIL16DOZ0392AA 2

The angle cylinder base end (3) — one each side.  
The lift cylinder rod end (4) — one each side.

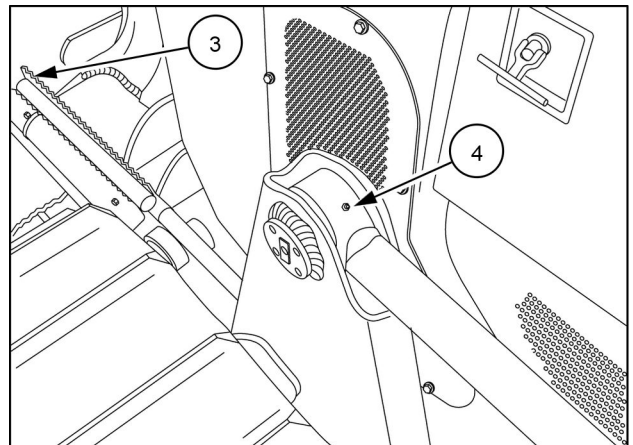

RAIL12DOZ0360AA 3

## Fuel filter (Initial)

### ⚠ WARNING

**Fire hazard!**

**When handling diesel fuel, observe the following precautions:**

1. **Do not smoke.**
2. **Never fill the tank when the engine is running.**
3. **Wipe up spilled fuel immediately.**

**Failure to comply could result in death or serious injury.**

W0099A

Replace the fuel prefilter and the fuel filter when the hour meter registers 100 hours for a new machine during the initial run-in period. Fuel filters should be changed every 500 hours thereafter or more frequently when operating conditions are severe.

### Prior operation:

Keep all unauthorized personnel clear of the area. Park the machine on level ground, in neutral with the parking brake applied, and the attachment lowered to the ground, turn off the engine, remove the key, and verify that engine components have cooled or avoid contact. Make sure that all residual pressure is relieved from circuits before beginning maintenance.

1. Locate the fuel prefilter in the right rear access compartment. Close the fuel shut off valve to prevent fuel leakage.
2. Clean the fuel prefilter head, the outside of the fuel prefilter, and remove any dirt and debris around the area that might contaminate the system.

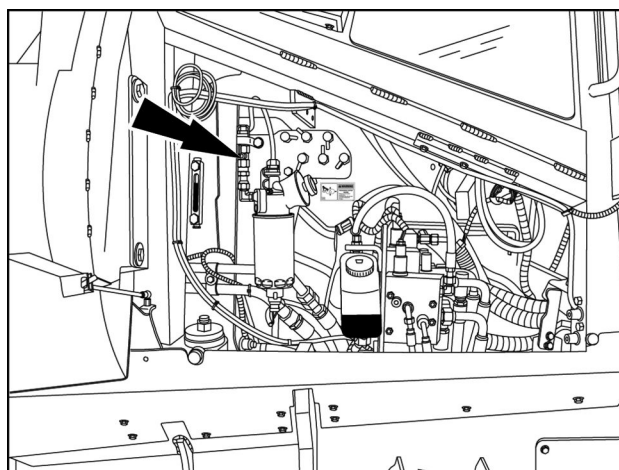

RAIL13DOZ1266AA 1

3. Disconnect the wire harness (1).
4. Turn the fuel prefilter (2) counterclockwise and remove. Capture any fuel remaining in the lines or the fuel prefilter, and discard properly.
5. Apply a thin layer of clean oil to the gasket on the new fuel prefilter.
6. Install the prefilter. Use your hands to tighten the fuel filter 1/2 to 3/4 turn after the fuel prefilter makes contact with the filter head.
7. Open the fuel shut off valve.
8. Check for leaks.
9. Reconnect the wire harness (1).

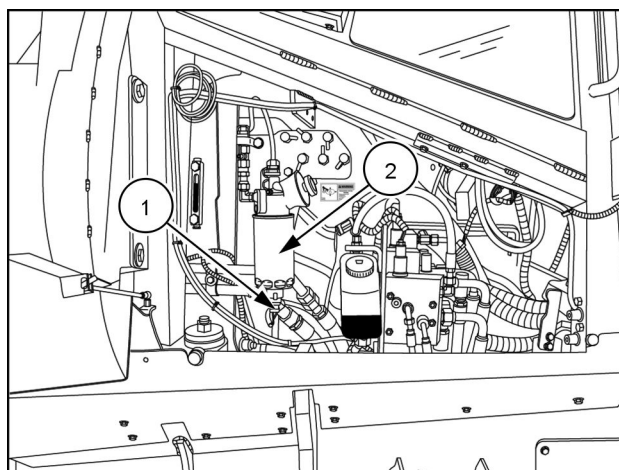

RAIL13DOZ1266AA 2

**NOTICE:** Never use a filter wrench to tighten a new fuel filter on install.

5. Remove the engine oil drain plug (2).

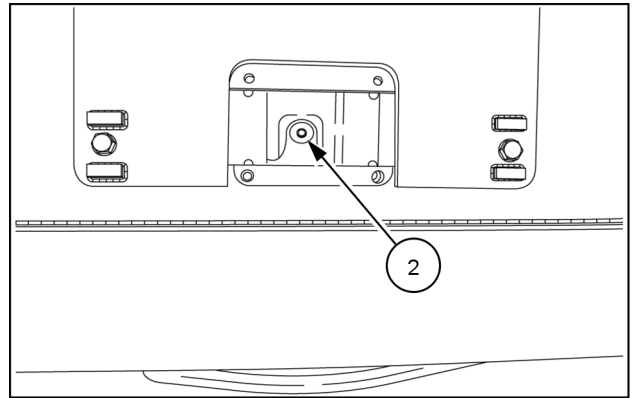

RAPH12DOZ0096AA 3

6. Locate the oil filter (3) in the right front engine compartment. Clean the area around the filter of dirt and debris.

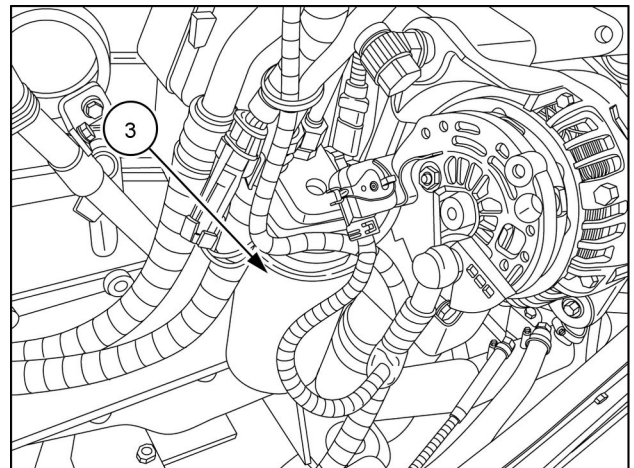

RAIL12DOZ0192AA 4

### Replace oil filter

7. Turn the oil filter (3) housing counterclockwise to remove. Remove and discard the filter following local environmental and waste regulations.
8. Apply a thin layer of clean oil to the new filter gasket.
9. Turn the new oil filter onto the base until the gasket makes contact with the base, and then turn by hand an additional 3/4 turn. Never use a filter wrench to install a new filter.

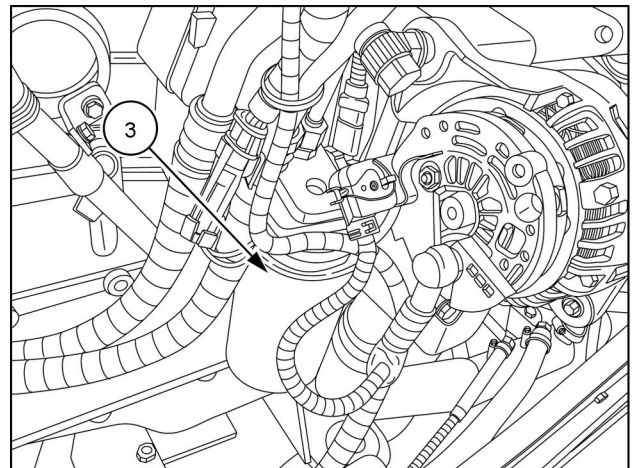

RAIL12DOZ0192AA 5

10. Close the oil drain.

## Hydraulic reservoir breather

### ⚠ WARNING

Pressurized hydraulic fluid can penetrate the skin and cause severe injuries. Hydraulic fluid is under extreme pressure. Rest the bucket or attachment on the ground. Shut the engine off, turn the key on, and move the hydraulic control lever through all movements several times to relieve residual pressure in the system. Failure to comply could result in death or serious injury.

W0161A

### ⚠ WARNING

Pressurized fluid can penetrate the skin and cause severe injuries. Keep hands and body away from any pressurized leak. **DO NOT** use your hand to check for leaks. Use a piece of cardboard or paper. If fluid penetrates the skin, seek medical attention immediately. Failure to comply could result in death or serious injury.

W0158A

Replace the hydraulic reservoir breather when the hour meter registers 1000 hours. The hydraulic reservoir breather should be replaced every 1000 hours thereafter or more frequently when operating conditions are severe.

### Prior operation:

Keep all unauthorized personnel clear of the area. Park the machine on level ground, in neutral with the parking brake applied, and the attachment lowered to the ground, turn off the engine, remove the key, and verify that engine components have cooled or avoid contact. Make sure that all residual pressure is relieved from circuits before beginning maintenance.

1. Remove the bolts from the access panel at the right rear of the machine in order to access the hydraulic reservoir breather.

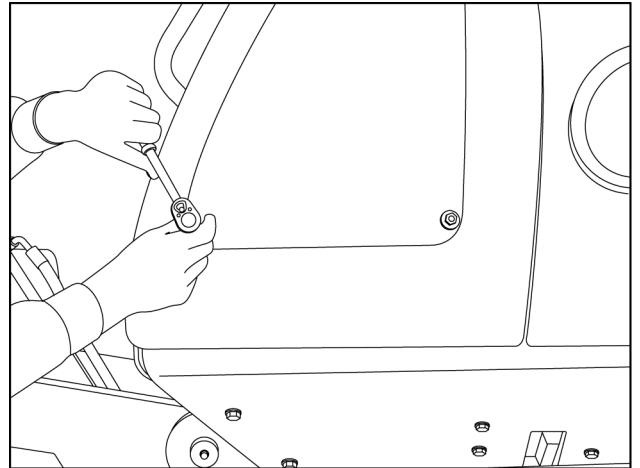

RAIL12DOZ0177AA 1

2. Clean the area around the breather.

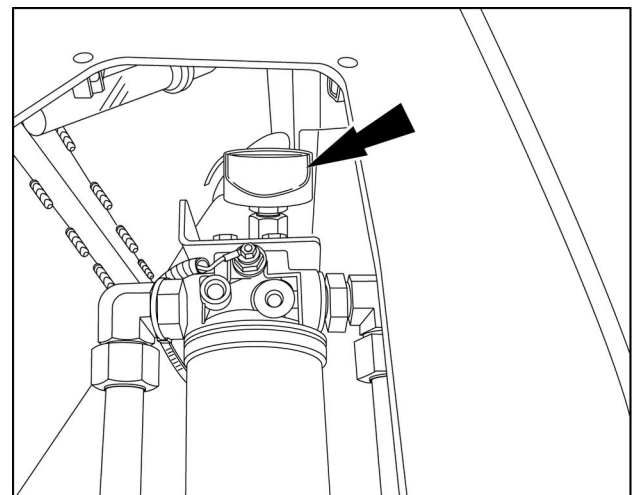

RAIL12DOZ0372AA 2

6. Using needle nose pliers, remove the DEF supply filter using care not to damage or bend the DEF supply filter.
7. Inspect the DEF supply filter housing, and rinse with water. Replace the DEF supply filter if damaged.
8. Reinstall the DEF supply filter into the DEF supply line, and reconnect the DEF supply lines.

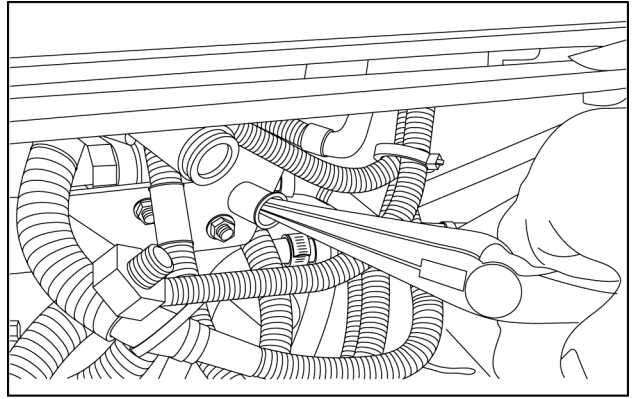

RAPH12DOZ0323AA 4

9. Secure the DEF supply module to the mounting bracket.
10. Start the engine and run at idle speed.
11. Check for leaks around all connections.

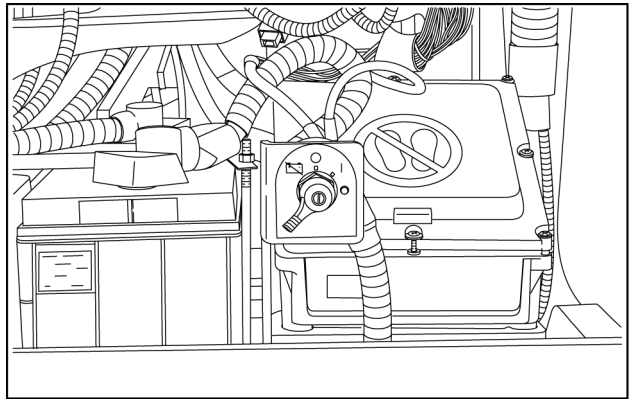

RAPH12DOZ0044AA 5

## Engine air filters

Check the engine air filter periodically for dirt and debris build up. Replace the engine primary and secondary air filter every 2000 hours or each year, whichever occurs first.

### Prior operation:

Keep all unauthorized personnel clear of the area. Park the machine on level ground, in neutral with the parking brake applied, and the attachment lowered to the ground, turn off the engine, remove the key, and verify that engine components have cooled or avoid contact. Make sure that all residual pressure is relieved from circuits before beginning maintenance.

**NOTICE:** Replace the primary element if the filter warning lamp on the instrument cluster illuminates or the audible alarm sounds. If the caution warnings continue after replacing the primary filter, replace the secondary filter. Under normal conditions, you should replace the secondary filter after three primary filter replacements. Replace filters more often if conditions so warrant. DO NOT clean the secondary filter. You must replace the secondary filter.

1. Locate the engine air filter in the main engine compartment.

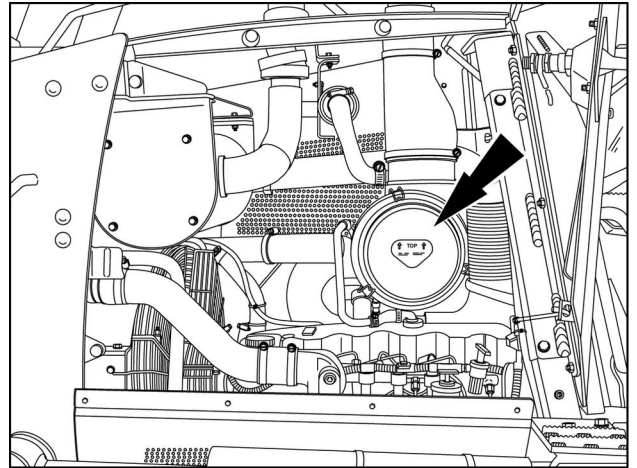

RAIL13DOZ0949AA 1

2. Release the locks (1) on the cover (2).

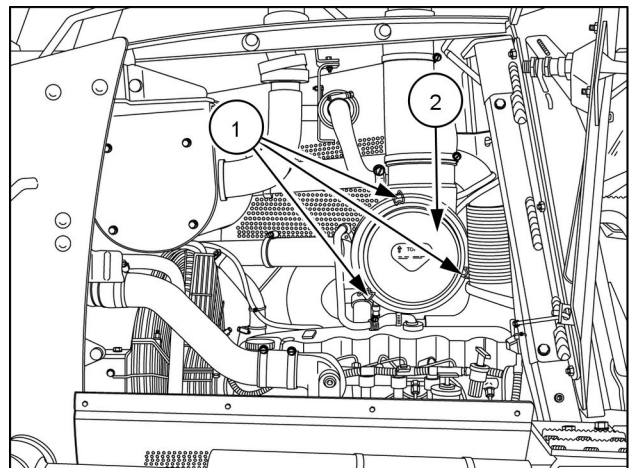

RAIL13DOZ0949AA 2

## Cab air filter

### ⚠ WARNING

**Eye injury hazard!**

**Wear full coverage safety glasses with side panels when using compressed air. Limit air pressure to 200 kPa (29 psi).**

**Failure to comply could result in death or serious injury.**

W0162A

The cab recirculation air filter is located behind the operator's seat. Replace the cab air filters when required. The cab air filter is located behind the operator compartment near the exhaust fan.

### Prior operation:

Keep all unauthorized personnel clear of the area. Park the machine on level ground, in neutral with the parking brake applied, and the attachment lowered to the ground, turn off the engine, remove the key, and verify that engine components have cooled or avoid contact. Make sure that all residual pressure is relieved from circuits before beginning maintenance.

### Recirculation filter

1. Remove the retaining screw that holds the recirculation filter cover in place, and remove the recirculation filter.
2. Wipe the housing clean.

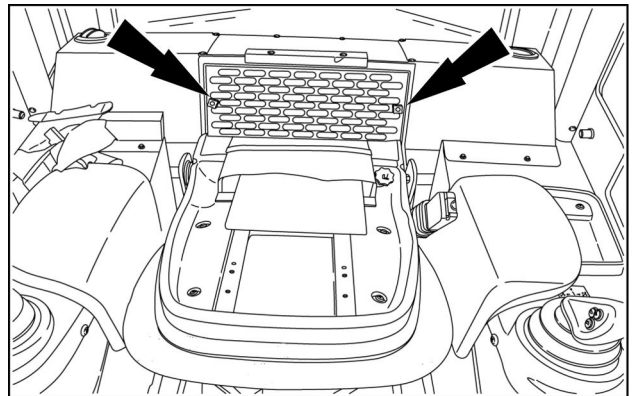

RAPH12DOZ0074AA 1

3. Replace the recirculation filter with a new one.
4. Reinstall the new recirculation filter, and secure the access filter cover.

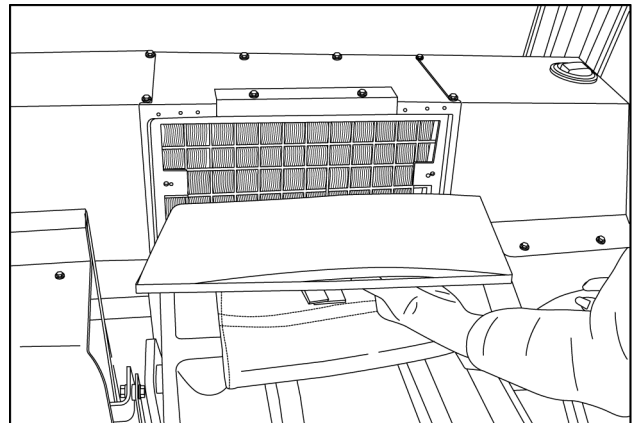

RAIL12DOZ0164AA 2

## Ripper shanks and teeth

### ⚠ WARNING

**Flying object!**  
**Always wear eye or full face protection when performing this procedure.**  
**Failure to comply could result in death or serious injury.**

W0313A

Ripper shanks or ripper teeth may require periodic replacement. Use care when lifting heavy objects. Always use adequate lifting equipment.

### Prior operation:

Keep all unauthorized personnel clear of the area. Park the machine on level ground, in neutral with the parking brake applied, and the attachment lowered to the ground. Make sure that all residual pressure is relieved from circuits before beginning maintenance.

### Adjusting the ripper shanks

1. Locate the threaded hole on top of the ripper shank.

### 2. ⚠ CAUTION

**Heavy object!**  
**The component is heavy. Use care not to drop the component when installing, removing, or handling.**  
**Failure to comply could result in minor or moderate injury.**

C0095A

Insert an appropriate lifting eyelet into the ripper shank. Attach appropriate lifting equipment and place tension on the lift strap.

3. Remove the bolt (1) and retaining washer (2).

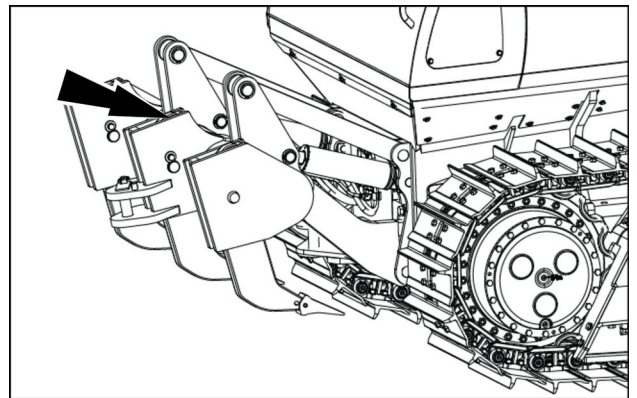

RAIL16DOZ0824AA 1

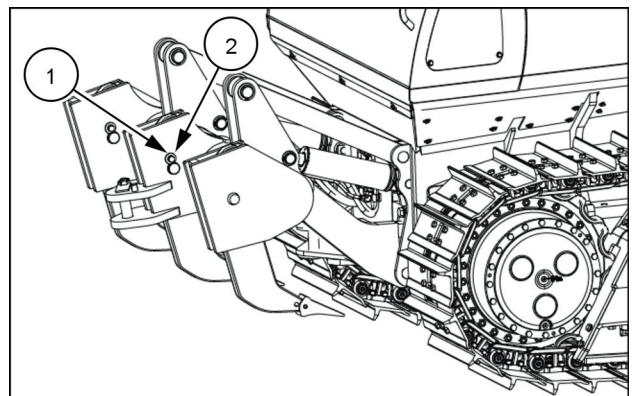

RAIL16DOZ0824AA 2

## Work lights

### Prior operation:

Keep all unauthorized personnel clear of the area. Park the machine on level ground, in neutral with the parking brake applied, and the attachment lowered to the ground, turn off the engine, remove the key, and verify that engine components have cooled or avoid contact. Make sure that all residual pressure is relieved from circuits before beginning maintenance.

1. To replace work lights, remove the Phillips screws from the front of the light.

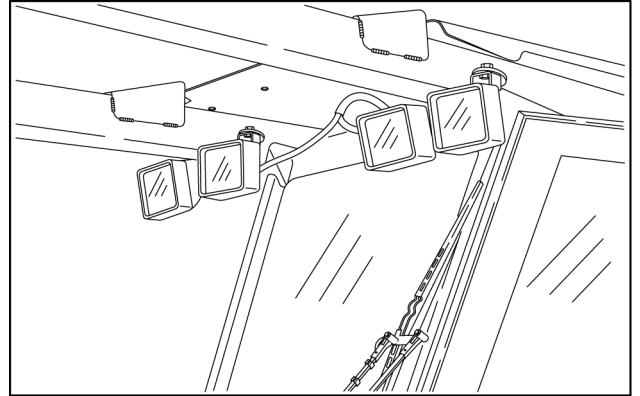

RAPH12DOZ0104AA 1

2. Disconnect push on connectors, and replace the lamp assembly. Push the connectors on, making certain connections are firmly in place.
3. Replace the lamp assembly, and secure the frame with the Phillips screws.

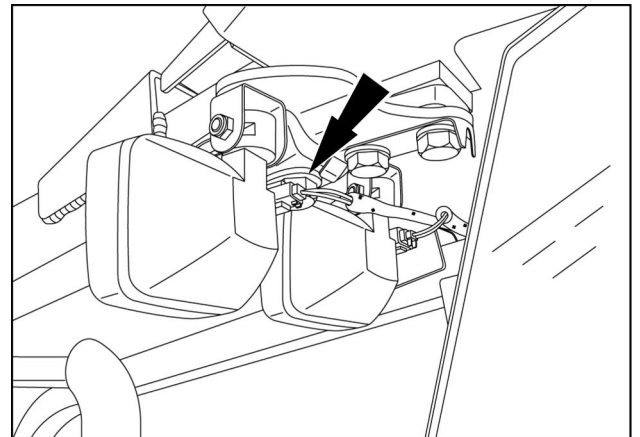

RAIL12DOZ0196AA 2

## Fluids and lubricants

### Capacities

Engine crankcase	
Capacity with filter	16.0 L (16.9 US qt)
Capacity without filter	13.0 L (13.7 US qt)
Specifications	CASE AKCELA UNITEK NO. 1™ SBL CJ-4 SAE 10W-40
Fuel tank	
Capacity	322.0 L (85.1 US gal)
Selective Catalytic Reduction System — DEF/AdBLUE®	
Capacity	62.0 L (16.4 US gal)
Cooling system	
Capacity	28.0 L (7.4 US gal)
Specifications	50% distilled or demineralized water and 50% or CASE AKCELA ACTIFULL™ OT EXTENDED LIFE COOLANT Machines with OAT coolant will have a decal near the fill location. Never mix conventional coolant with OAT coolant. See 7-21 for additional information.
Hydraulic reservoir/Transmission refill	
Capacity	193.0 L (51.0 US gal)
Specifications	TUTELA AUTO SUPREME™ ENGINE OIL SAE 10W-30
Final drives	
Capacity - Each Side	15.6 L (16.5 US qt)
Specifications	CASE AKCELA GEAR LUBE 135 H EP 85W-140
Grease fittings	
Quantity	As Required
Specifications	TUTELA MOLY GREASE GR-75

**NOTE:** If the ambient temperature is lower than -37 °C (-34.6 °F), adjust the mixture according to the coolant manufacturer specifications.

## 9 - ACCESSORIES

### Radio (if equipped)

A radio (if equipped) is available for this machine from your authorized dealer. Refer to the radio manufacturer's instructions for correct operation.

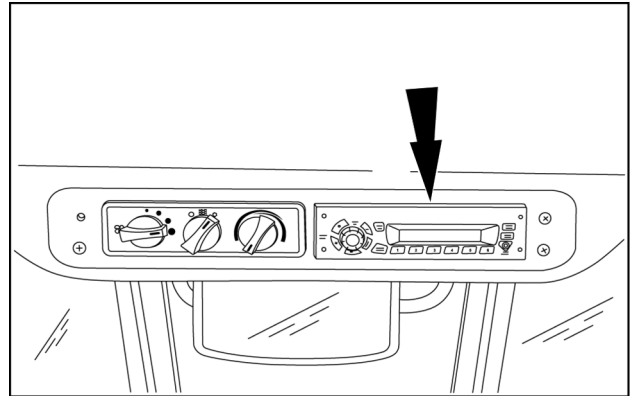

RAPH12DOZ0083AA 1

CLICK HERE TO **DOWNLOAD** THE COMPLETE MANUAL

- Thank you very much for reading the preview of the manual.
- You can download the complete manual from: [www.heydownloads.com](http://www.heydownloads.com) by clicking the link below



- Please note: If there is no response to CLICKING the link, please download this PDF first and then click on it.

CLICK HERE TO **DOWNLOAD** THE COMPLETE MANUAL