

ORIGINAL INSTRUCTIONS

1021G
1121G
Tier 4B (Final)
Wheel Loader

OPERATOR'S MANUAL

Part number 51417057
1st edition English
November 2017



CLICK HERE TO **DOWNLOAD** THE COMPLETE MANUAL

- Thank you very much for reading the preview of the manual.
- You can download the complete manual from: www.heydownloads.com by clicking the link below



- Please note: If there is no response to CLICKING the link, please download this PDF first and then click on it.

CLICK HERE TO **DOWNLOAD** THE COMPLETE MANUAL

Electro-Magnetic Compatibility (EMC)

Interference may arise as a result of add on equipment which may not necessarily meet the required standards. Such interference can result in serious malfunction of the unit and/or create unsafe situations, you must observe the following:

- The maximum power of emission equipment (radio, telephones, etc.) must not exceed the limits imposed by the national authorities of the country where you use the machine.
- The electromagnetic field generated by the add on system should not exceed **24 V/m** at any time and at any location in the proximity of electronic components.
- The add on equipment must not interfere with the functioning of the on board electronics.

Failure to comply with these rules will render the CASE CONSTRUCTION warranty null and void.

Personal safety

Most accidents involving machine operation and maintenance can be avoided by following basic safety rules and precautions. Read and understand all the safety messages in this manual, the safety manual and the safety signs on the machine before you operate or service the machine. See your dealer if you have any questions.

READ THIS MANUAL COMPLETELY and make sure you understand the controls. All equipment has a limit. Make sure you understand the speed, brakes, steering, stability, and load characteristics of the machine before you start to operate this machine.

DO NOT remove this manual or the safety manual from the machine. See your dealer for additional manuals. Also see the manual information on the Title pages (first and second pages in front of the Table of Contents) of this manual.

The safety information given in this manual does not replace safety codes, insurance needs, federal, state, or local laws. Make sure that your machine has the correct equipment according to these rules or laws.

Additional safety messages are used in the text of the manual to show specific safety hazards.

NOTICE: *the safety messages in this chapter point out conditions which can happen during the normal operation and maintenance of your machine. These safety messages also give possible ways of dealing with these conditions.*

Support strut and service link

⚠ WARNING

Crushing hazard!

If you service the machine with the loader lift arms raised, always use the support strut. Remove the support strut from the storage position and place the strut onto the cylinder rod. Install the retaining bolt entirely into the strut. Lower lift arms onto the support strut.

Failure to comply could result in death or serious injury.

W0140A

If you service the machine with the loader lift arms raised, always use the support strut.

Support strut

1. Empty the loader bucket, park the machine on a level surface, raise the loader lift arms to approximately **2.1 m (7 ft)**, turn the engine off and set the parking brake before exiting the cab. Maintain the bucket in a dumped position. Remove the support strut from the storage position by removing the retaining bolt.

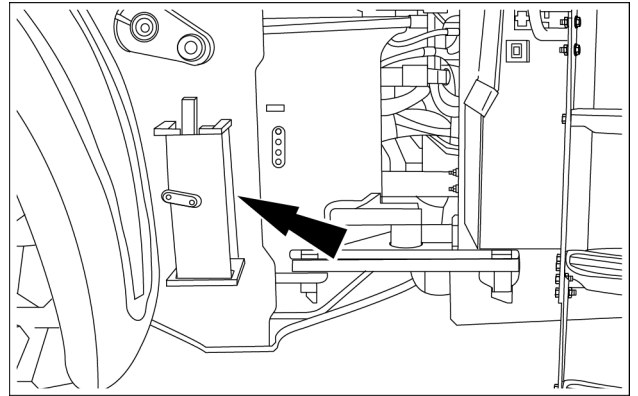

LEIL16WHL1598AB 1

2. Place the support strut onto the cylinder rod with the guide lock tab on the top of the cylinder and pointing toward the bucket. Install the retaining bolt entirely into the support strut using all threads. Slowly lower the lift arms onto the support strut. Maintain the bucket in a dumped position.

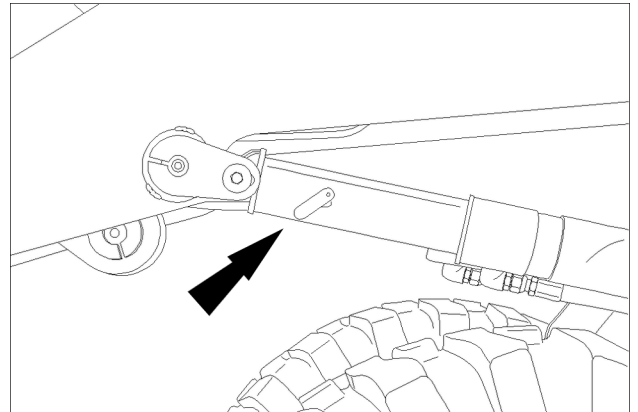

RCPH10WHL061BAL 2

Empty tool

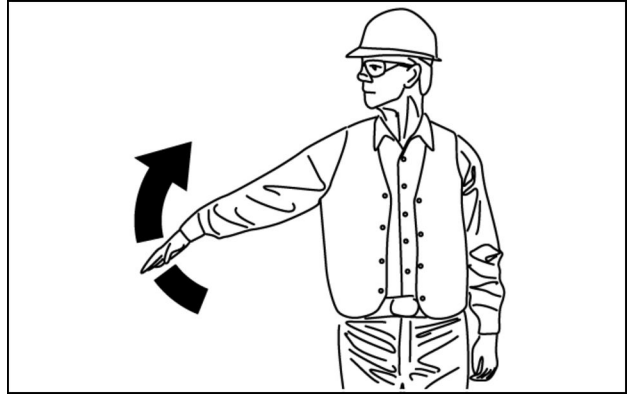

LEEN11T0024AA 20

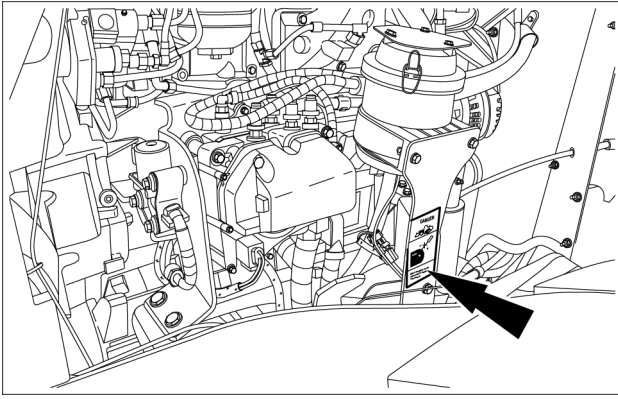

LEIL16WHL1008AB 35

Location: left-hand side of the engine compartment, near the fan guard.

DANGER

Unexpected movement!

Start the engine from the operator's seat.

Transmission must be in neutral.

Failure to comply will result in death or serious injury.

North American decal number: 87488616

French Canadian decal number: 87488617

Spanish decal number: 87488618

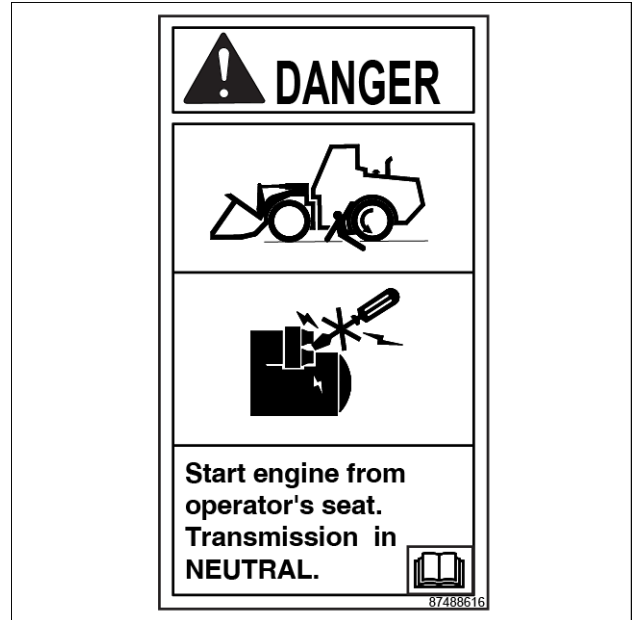

87488616_ 36

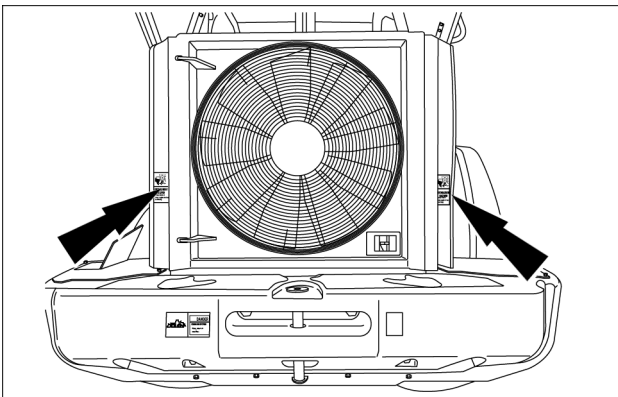

LEIL16WHL1004AA 37

Location: on the cooling frame on the rear side of the machine.

WARNING

Entanglement hazard!

Keep clear or stop the engine before servicing.

Failure to comply with this warning could result in death or serious injury.

North American decal number: 87488606

French Canadian decal number: 87488607

Spanish decal number: 87488608



87488606_1 38

Headrest (Optional)

The seat is equipped at the top with provisions for optional headrest.

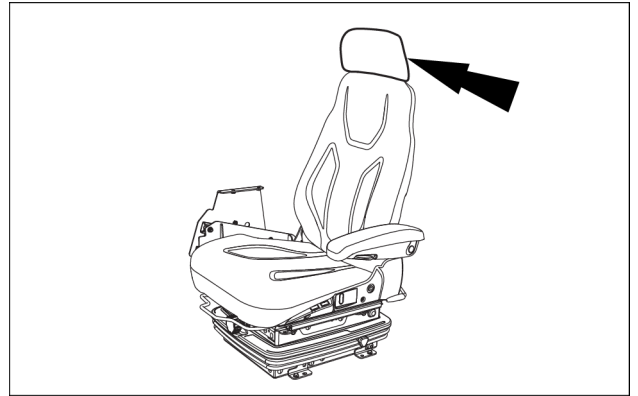

LEIL16WHL1391AB 8

Pedal controls

Brake pedal

When pushed, the brake pedal actuates the machine brakes.

NOTE: the pedal works in conjunction with the transmission declutch switch for more efficient braking. See "Loader functions – Declutch switch" – Chapter 4 in this manual for further information.

NOTICE: on steep slopes, use the down shift mode of the transmission to aid braking and to help prevent brake overheating and premature disc wear.

NOTE: when the machine is shut off, the parking brake is automatically set.

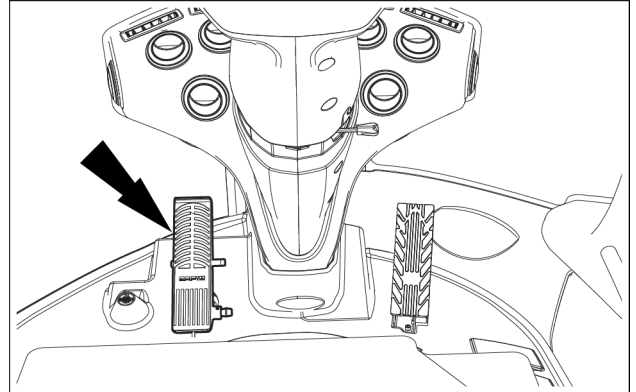

LEIL16WHL1556AB 1

Foot Throttle

Push the foot throttle to increase the engine speed. When the pedal is released the engine runs at low idle.

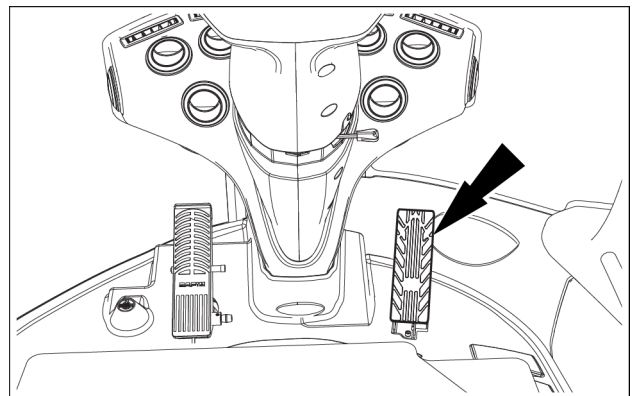

LEIL16WHL1557AB 2

Differential lock (Optional)

Depress the differential lock foot switch to lock the front axle differential. Release the switch to unlock the differential.

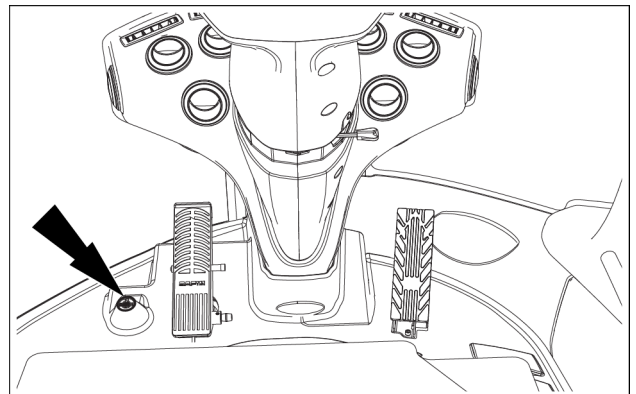

LEIL16WHL1558AB 3

5. Auxiliary F-N-R



Press the auxiliary F-N-R button to enable/disable the auxiliary F-N-R switch located on the joystick or next to the single axis levers.
See Chapter 4 for further information.
LED color: green.

6. Auto shift



Press the auto shift button to enable/disable the automatic operation mode for the transmission. When the auto shift function is activated, the transmission will automatically shift up and down between 1st or 2nd and the highest speed setting on the transmission control lever.
See Chapter 4 for further information.
LED color: green.

7. De-clutch (4-speed only) / Power inch (5-speed only)

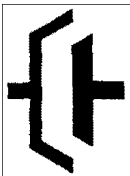

Press the de-clutch/power inch button to enable/disable the de-clutch on 4-speed transmissions or power inch on 5-speed transmissions. This feature can improve loader applications when truck loading and tight corner operations are required.
See Chapter 4 for further information.
LED color: green.

8. Torque converter lock-up (5-speed only)



Press the torque converter lock-up button to enable/disable the torque converter lock-up function. This function allows a direct mechanical connection between the engine and the transmission to eliminate torque converter loss. It allows the operator to remain locked up from the second gear upward. It allows for faster vehicle accelerations and speeds.
LED color: green.

9. Automatic differential lock (if equipped)

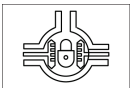

With the automatic differential lock button in ON position, the automatic differential lock system is enabled. The hydraulic differential lock will automatically engage when required for the wheel loader. The differential lock is activated any time the operator presses the differential lock foot switch, regardless of whether the automatic differential lock system is enabled or not.
LED color: green.

10. Return-to-dig



Press the return-to-dig button to enable/disable the return-to-dig function. This function allows the bucket to return to level with the ground for digging.
See Chapter 4 for further information.
LED color: green.

11. Height control



Press the height control button to enable/disable the height control function. This function allows the bucket to raise to the set height position when activated.
See Chapter 4 for further information.
LED color: green.

12. Return-to-travel



Press the return-to-travel button to enable/disable the return-to-travel function. This function allows the bucket to automatically return to the travel position after you have dumped the loader bucket.
See Chapter 4 for further information.
LED color: green.

3. Kick-down button

You can use the kick-down button **(1)** to shift down through the gears in single steps. Each time you press the kick-down button **(1)**, the transmission will shift down one gear range until the first gear is reached. Once the kick-down button **(1)** has been pressed down, the transmission maximum gear allowed is lowered. The kick-down button **(1)** will return to the automatic mode in one of the two cases, as follows:

1. when the transmission control lever changes gear;
2. when the transmission control lever is moved to NEUTRAL and then to FORWARD or to REVERSE.

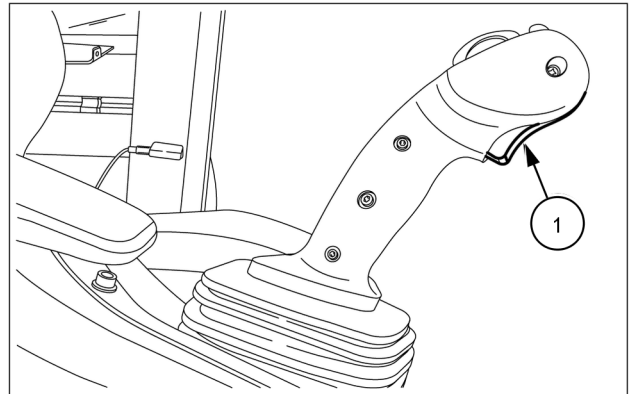

LEIL15WHL0652AB 18

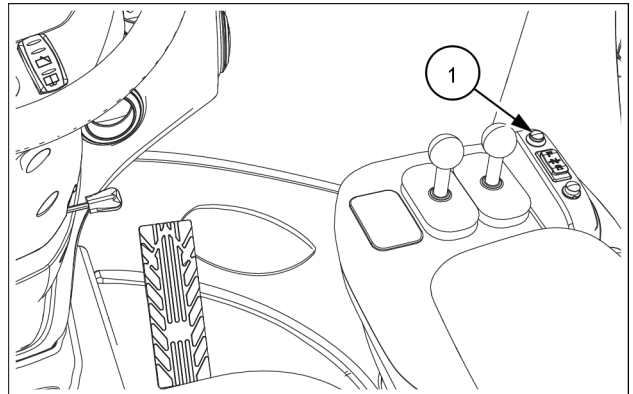

LEIL16WHL1303AA 19

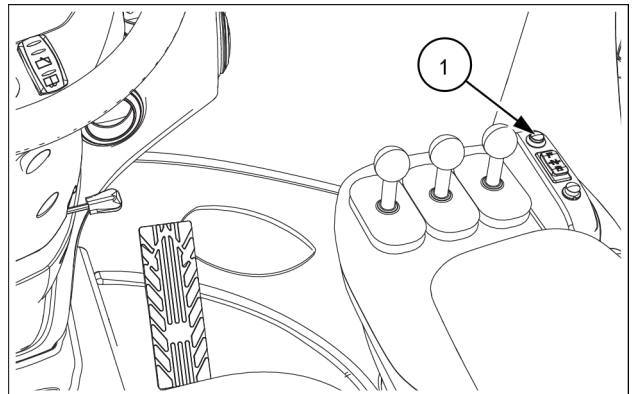

LEIL16WHL1302AA 20

MAIN MENU

After the key switch has been turned to ON, the operator or service technician may use the main menu to adjust the machine configurations to working conditions, to test components, to view faults that may have occurred, or to select preferences.

Items and selections in this menu are:

1. Machine status
2. Trip
3. Rearview Camera
4. Machine settings
5. Machine Service

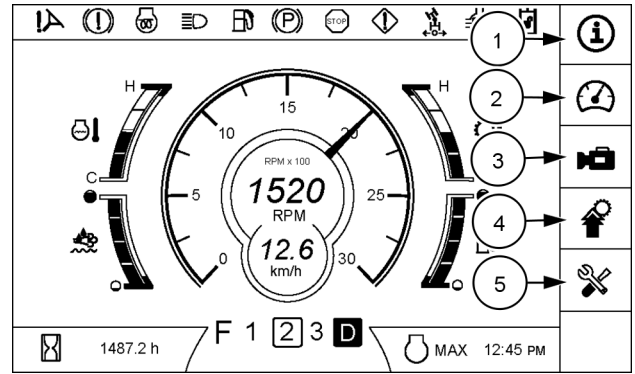

MACHINE SERVICE

Use the keypad on the right-hand of the display to select the key to access to the “Machine service” screens.

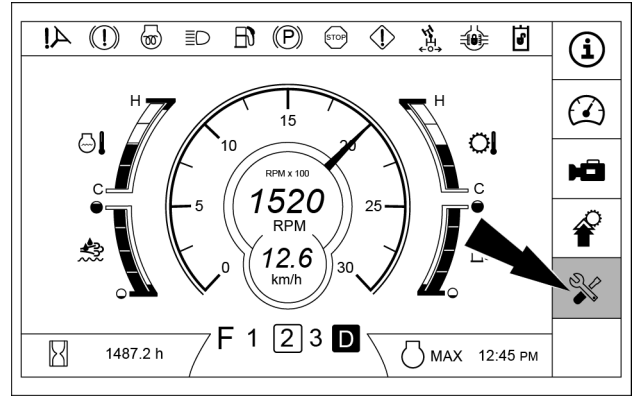

LEIL16WHL0908AA 30

Items and selections in this menu are:

- Maintenance
- Sensor Status
- Calibration Settings
- Controller Information
- Diagnostic Trouble Codes
- Keypad Diagnostics
- Security

Maintenance

Use the keypad on the right-hand of the display to select the key to switch to the “Maintenance” settings.

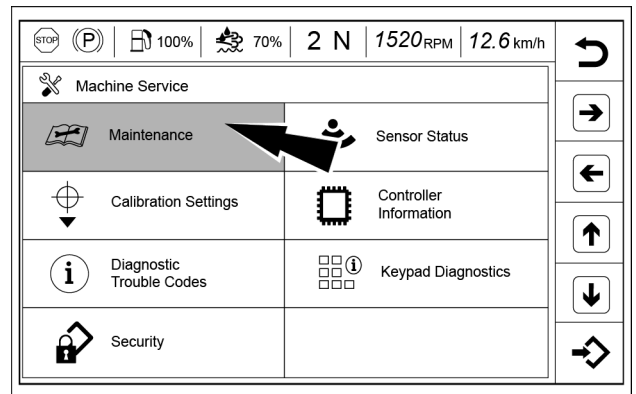

LEIL16WHL0910AA 31

→ Maintenance selections:

Cab air filter:

- Service Intervals Hrs: **250 h**
- Time to Service: (hours remaining until service is due)

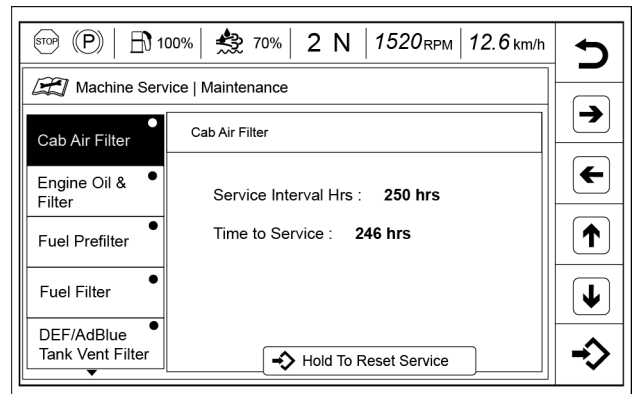

LEIL16WHL0896AA 32

→ Inch Pedal Calibration (5 speed only)

Conditions to be satisfied to start the inch pedal calibration:

- Key Switch ON with Engine NOT Running
- Place Transmission in Neutral
- Turn On Parking Brake

Select “Start” to proceed with the inch pedal calibration.

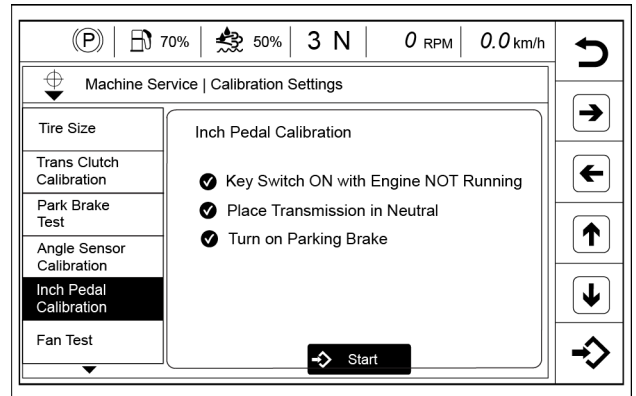

LEIL17WHL1638AA 69

Inch pedal calibration is in progress

Press the service brake pedal

Hold the service brake pedal pressed for acquisition

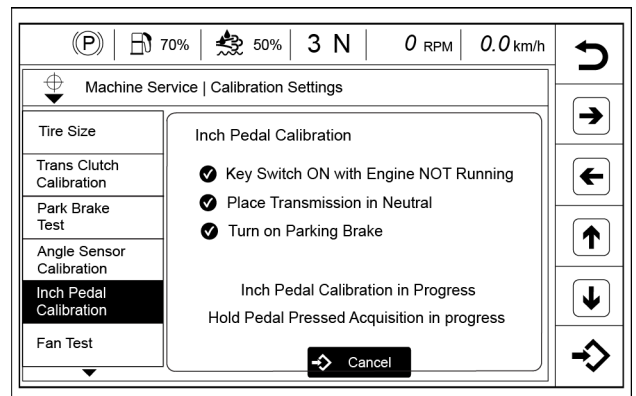

LEIL17WHL1640AA 70

Acquisition is in progress

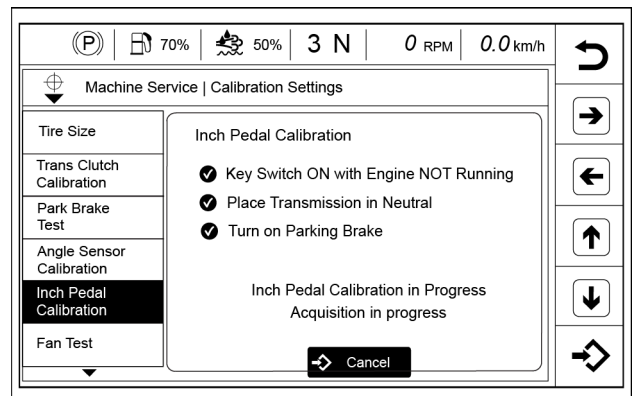

LEIL17WHL1641AA 71

Release the service brake pedal

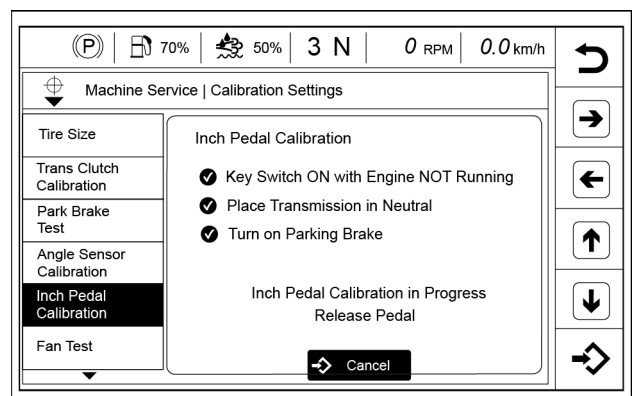

LEIL17WHL1642AA 72

Display	Description	Corrective Action
DEF/AdBLUE® Level, Tank EMPTY, Power Limited	DEF/AdBLUE® level is less than 5% of tank volume (0% will be displayed). Up to 65% torque reduction and 40% engine speed reduction within 40 min of engine running time.	Refill DEF/AdBLUE® immediately and reset the system by cycling the key switch OFF then ON.
DEF/AdBLUE® Level, Tank EMPTY, Ext. Power Lim	When the tank has reached 0% level, there is a 50% torque reduction, and engine speed is limited to low idle within an additional 30 min of engine run time.	Refill DEF/AdBLUE® immediately and reset the system by cycling the key switch OFF then ON.
Poor DEF/ AdBLUE® Quality Detected Power Limited	DEF/AdBLUE® quality/concentration is questionable 60 min after the initial warning. Up to 65% torque reduction and 40% engine speed reduction within 40 min of engine running time.	Drain DEF/AdBLUE® tank, clean and refill with approved DEF/AdBLUE® solution. Contact your local authorized dealer if failure persists. <i>NOTE: see “DEF/AdBLUE® tank refilling” section for important tank draining information.</i>
DEF/AdBLUE® Injection Failed Ext. Power Lim	SCR fault/failure detected. Up to 65% torque reduction and 50% engine speed reduction within 30 min .	Contact your local authorized dealer for repair, cycle key, or validation re-start.

4. Heated mirror

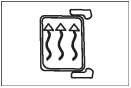

Push the rocker switch **(4)** to turn the heated mirror function ON. This feature allows to heat the external mirrors and keeps the operator's field of vision clear of ice, frost, freezing rain.

5. Rear window defrost



Push the rocker switch **(5)** to activate the rear window defrost.

Operating in extreme temperatures

Operating the machine in hot climates

1. Keep the coolant at the correct level in the coolant reservoir and in the radiator.
2. Use the correct solution of ethylene glycol and water in the cooling system.
3. Check the cooling system cap before hot weather starts. Replace the cap as required. Replace with a genuine replacement part to insure the correct PSI rated cap.
4. Clean all dirt and debris from the radiator, cooler, and engine area.
5. Check the condition of the engine accessory drive belt.
6. Use lubricants of the correct viscosity. See Fluids and lubricants in Chapter 7 – Maintenance.
7. Check battery fluid levels.

Two function valve - two single axis levers

NOTE: this page shows the basic two control lever positions.

See "Loader functions" - Chapter 4 in this manual for return-to-dig, bucket height control, return-to-travel and float functions.

1. Dump bucket
2. Rollback bucket
3. Raise lift arms
4. Lower lift arms
5. Hold (central position) - The loader arms and bucket will not move when the control levers are in the hold position. When released, the control levers will automatically return to the hold position.
6. Float - When in the float position, the loader bucket floats across the rough ground.

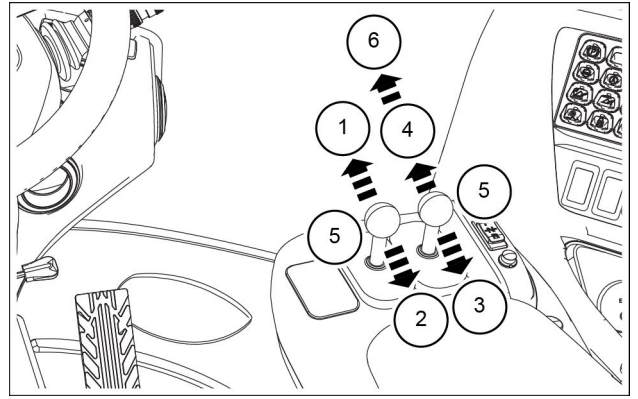

LEIL16WHL1333AB 3

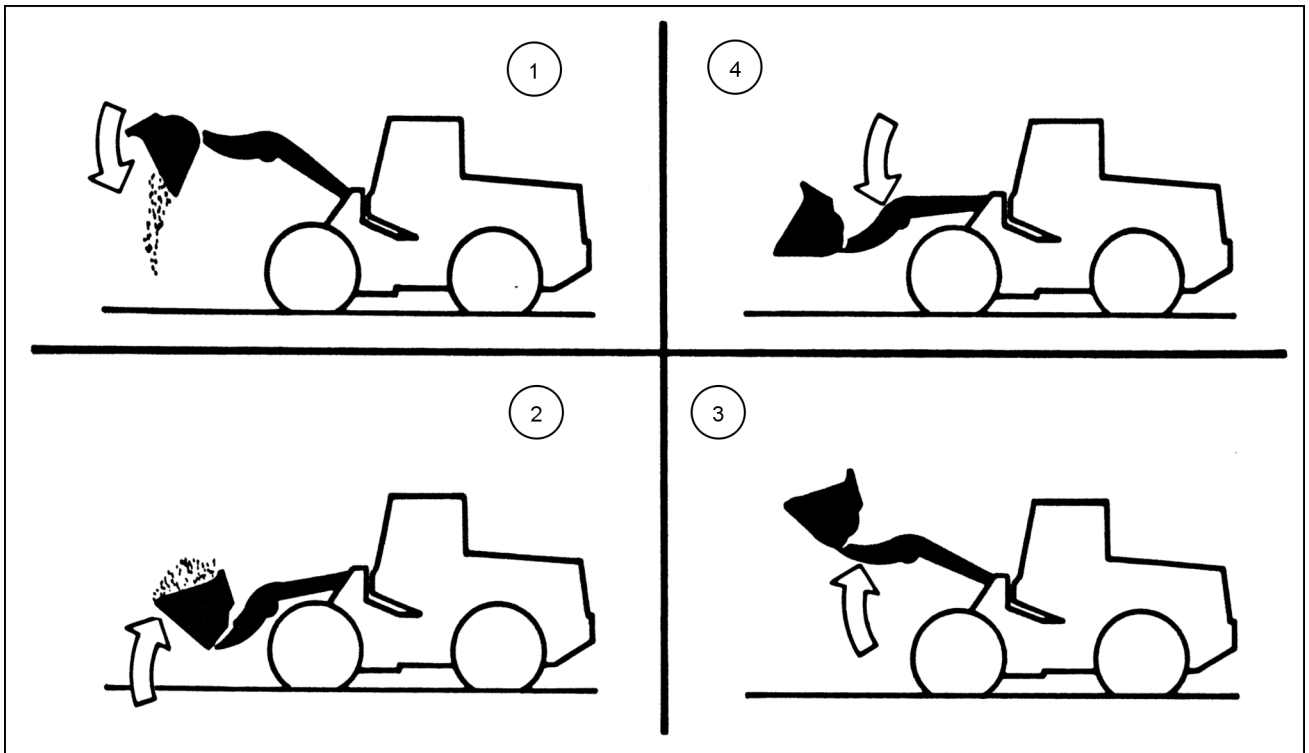

RCPH10WHL045BAH 4

5 - TRANSPORT OPERATIONS

7. Place the transport service link in the locked position.
8. Use provided tie down locations to safely secure the machine. Chains must be securely fastened to the tie down holes and trailer. Tie down locations are indicated on the machine with tie down decals.

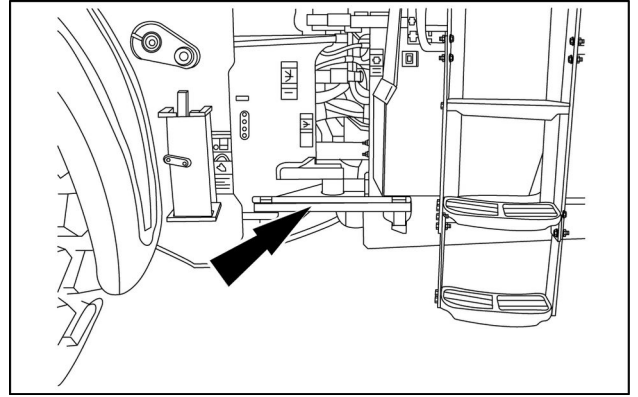

LEIL15WHL1782AA 2

9. Fasten securely the chains around the left-hand and right-hand side of the loader arm.
10. Put a cover over the exhaust pipe.
11. Measure the distance between the ground and the highest point of the machine. You must know the clearance height of machine on the trailer.
12. Advise the driver of the machine weights and attachments if special permits or guidelines are necessary.

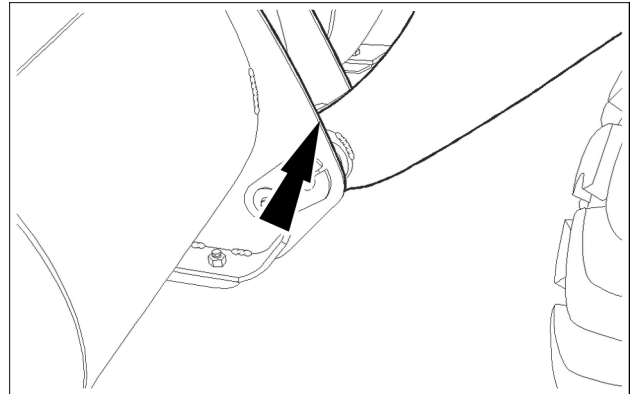

LEIL16WHL0090AB 3

CLICK HERE TO **DOWNLOAD** THE COMPLETE MANUAL

- Thank you very much for reading the preview of the manual.
- You can download the complete manual from: www.heydownloads.com by clicking the link below



- Please note: If there is no response to CLICKING the link, please download this PDF first and then click on it.

CLICK HERE TO **DOWNLOAD** THE COMPLETE MANUAL

Joystick steering activation

The joystick steering switch is a two position rocker switch for activation/deactivation of joystick steering function. The joystick steering switch is located on the joystick steering console.

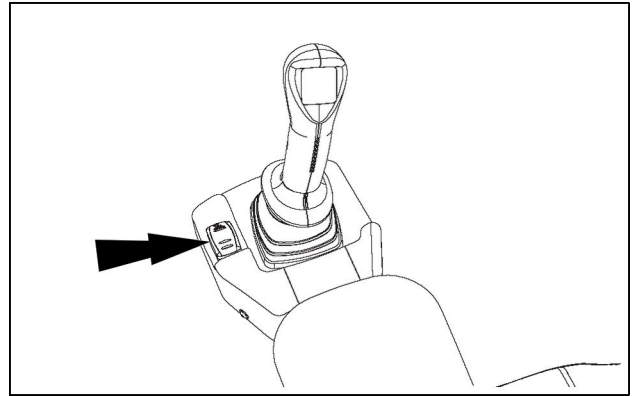

LEIL16WHL1406AA 4

The joystick steering indicator on the display will illuminate, indicating that the machine travel is operated with the joystick. To return the steering wheel to operation, stop the machine in neutral, engage the brake, and roll downward the joystick steering switch. The joystick steering speed can be set with the “Machine Settings” menu.

NOTICE: if the operator moves the standard steering wheel, the joystick steering function automatically ceases and steering capabilities return to the standard steering wheel. When the steering wheel is released, the operator can return to joystick steering, and joystick steering will again be functional. The operator can also choose to turn off joystick steering at this time if the operation is complete.

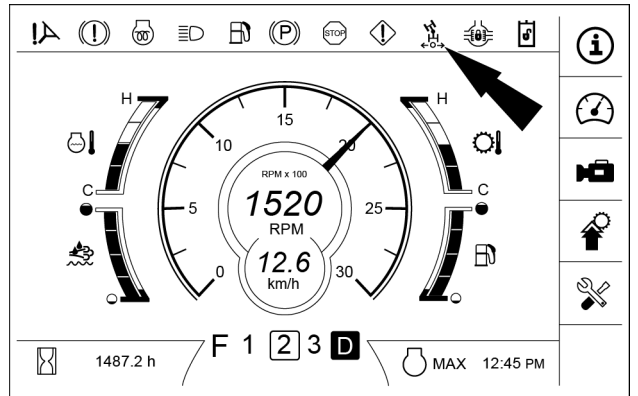

LEIL16WHL0407AB 5

Before activating the joystick steering:

1. Stop the wheel loader.
2. Lower the left-hand armrest in the horizontal position.
3. Move the transmission control lever on the steering column to the NEUTRAL position.

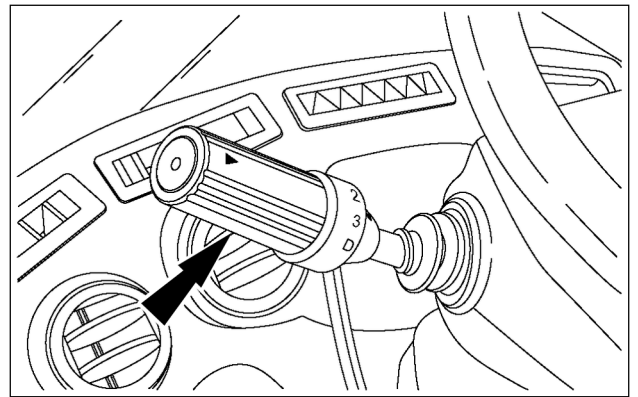

LEIL16WHL1468AA 6

4. Steering and travel are directed with the joystick steering control lever only when the joystick steering is activated.

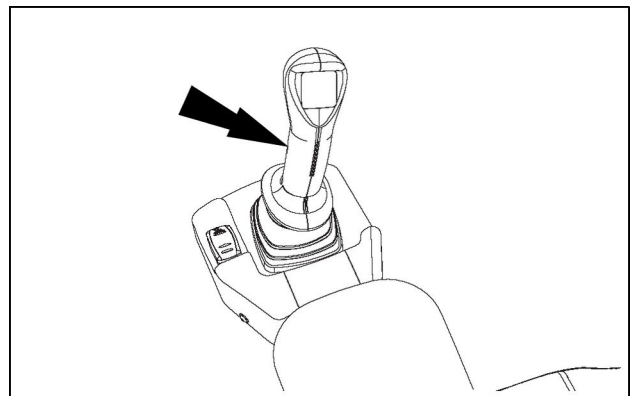

LEIL16WHL1406AA 7

- Wear and corrosion of internal components due to water content, which affects lubricity.
- Deterioration of some rubber sealing compounds in the fuel system.
- Biodiesel oxidation, which can lead to the formation of deposits that can harm the fuel injection system.

NOTICE: any problem in the engine fuel injection equipment associated with non-compliance to the following conditions for biodiesel fuel handling and maintenance will not be covered for Warranty by CASE CONSTRUCTION.

Purchase biodiesel fuel from a trusted supplier who understands the product and maintains acceptable fuel quality. The National Biodiesel Board awards **BQ-9000®** accreditation to biodiesel marketers and producers that meet strict quality and consistency standards. Biodiesel users in North America are strongly encouraged to purchase biodiesel blends from the **BQ-9000®** Certified Marketers and sourced from the **BQ-9000®** Accredited Producers found on the **BQ-9000®** website.

The use of biodiesel blends up to B5 will not void the CASE CONSTRUCTION warranty as long as the following conditions for biodiesel fuel handling and maintenance are stringently followed:

Biodiesel fuel must be pre-blended by the supplier. Mixing biodiesel fuels on-site can result in an incorrect mixture that could damage the engine and/or fuel system.

NOTICE: CASE CONSTRUCTION may void your warranty if the problem is associated with poor fuel quality due to improper blending. It is the responsibility of the fuel supplier and/or yourself to ensure the right type of fuel and blend is delivered and used.

Storage

The machine should not be stored for more than 6 months with biodiesel in the fuel system. For longer storage time, it is strongly suggested that only regular #2 diesel fuel is used.

NOTE: if storage for longer than 6 months is necessary, the engine must be run on regular #2 diesel for a minimum of 20 hours to flush the biodiesel fuel out of the fuel system prior to storage.

Biodiesel is highly hygroscopic and tends to collect water more than diesel fuel. This increases the risk of algae and bacteria growth which can cause severe damage to the fuel injection system. Keep the machine fuel tanks and on-site storage tanks as full as possible to limit the amount of air and water vapors inside the tank. Drain water from the tanks at least once a week.

NOTICE: use only CASE CONSTRUCTION approved biocide additives on TIER4B engines with an exhaust aftertreatment system.

Limited B10 biodiesel approval

CASE CONSTRUCTION approves the use of up to B10 on TIER4B engines only in Minnesota (or other States & Provinces) where the state legislation mandates its usage during the months of April to September only and the state legislation mandates strict compliance of the B10 to specification **ASTM D7467**. The B10 must consist of a blend of S15 #2D Diesel Fuel per **ASTM D975** and B100 blend stock per **ASTM D6751** only.

Display	Description	Corrective Action
DEF/AdBLUE® Level, Tank EMPTY, Power Limited	DEF/AdBLUE® level is less than 5% of tank volume (0% will be displayed). Up to 65% torque reduction and 40% engine speed reduction within 40 min of engine running time.	Refill DEF/AdBLUE® immediately and reset the system by cycling the key switch OFF then ON.
DEF/AdBLUE® Level, Tank EMPTY, Ext. Power Lim	When the tank has reached 0% level, there is a 50% torque reduction, and engine speed is limited to low idle within an additional 30 min of engine run time.	Refill DEF/AdBLUE® immediately and reset the system by cycling the key switch OFF then ON.
Poor DEF/ AdBLUE® Quality Detected Power Limited	DEF/AdBLUE® quality/concentration is questionable 60 min after the initial warning. Up to 65% torque reduction and 40% engine speed reduction within 40 min of engine running time.	Drain DEF/AdBLUE® tank, clean and refill with approved DEF/AdBLUE® solution. Contact your local authorized dealer if failure persists. NOTE: see “DEF/AdBLUE® tank refilling” section for important tank draining information.
DEF/AdBLUE® Injection Failed Ext. Power Lim	SCR fault/failure detected. Up to 65% torque reduction and 50% engine speed reduction within 30 min .	Contact your local authorized dealer for repair, cycle key, or validation re-start.

Removal of NO_x requires a chemical reaction. This chemical reaction takes place in the SCR (13). DEF/AdBLUE® reacts with the SCR catalyst to convert NO_x to harmless nitrogen and water vapor.

To assure that the emission system is functioning correctly, a downstream NO_x sensor (16) is located in the exhaust stream at the outlet of the SCR.

The NH₃ sensor (15), located at the outlet of the SCR catalyst monitors ammonia (NH₃) levels to ensure the proper amount of DEF/AdBLUE® is being used.

Temperature is very important to the chemical reactions that take place in the emission control system. An SCR upstream temperature sensor (12) is located in the exhaust stream at the inlet of the SCR and compares the reading of the SCR downstream temperature sensor (14) located in the exhaust stream at the outlet of the SCR. The catalyst requires about **230 °C (446 °F)** for the chemical reaction to take place.

7 - MAINTENANCE

Maintenance action	Replace			Cleaning			Page no.
	Check	Grease		Change fluid			
		x	x	Drain fluid		x	
				x	x		
Front and rear axle oil - Change				x			7-110
Every 1500 hours							
Transmission oil - Change				x			7-113
Transmission oil filter - Replace			x				7-115
Transmission breather - Cleaning				x			7-117
Every 2000 hours							
Hydraulic oil - Change				x			7-118
Hydraulic oil filters - Replace			x				7-120
Primary engine air filter - Replace			x				7-123
Secondary engine air filter - Replace			x				7-126
Frame - Grease		x					7-129
Engine valve clearance - Check and adjust	x						7-130
Every 4000 hours							
Selective Catalytic Reduction System (SCR) supply module filter - Replace			x				7-131
Diesel Exhaust Fluid (DEF)/AdBlue® tank suction – Cleaning			x				7-134
Engine coolant - Change				x			7-137
As required							
Fuel pre-filter - Drain fluid					x		7-139
DEF/AdBlue® tank neck filter - Cleaning				x			7-140
Urea Quality Sensor (UQS) - Replace			x				7-143
Air conditioning condenser - Clean				x			7-144
Parking brake - Check	x						7-145
Secondary steering - Check	x						7-147
Cab service - Check	x						7-149
Platform, cab, bodywork, and decals - Check	x						7-152
Cooling box components- Check and clean				x			7-153
ELECTRICAL SYSTEM							
Battery - Cleaning				x			7-154
Battery electrolyte level - Check	x						7-157
Auxiliary battery connections - Check	x						7-158
Battery - Replace			x				7-161
Fuses and relays - Replace			x				7-162
Lights - Replace			x				7-167

Transmission oil level - Check

Check the transmission oil level every 50 hours of operation.

Prior operation:

Keep all non-authorized personnel clear of the area. Park the machine on level ground, in neutral with the parking brake applied and the attachment lowered to the ground. The transmission oil level sight gauge is on the left-hand side of the machine.

Service specifications	
Type of oil	CASE AKCELA NEXPLORE™ FLUID
1021G Capacity	45.4 l (48.0 US qt)
1121G Capacity	45.4 l (48.0 US qt)

Cold oil level check

Before you start the engine, check the transmission oil level in the sight gauge. If the oil level is below the arrow, add **CASE AKCELA NEXPLORE™ FLUID** to raise the oil level up to the arrow.

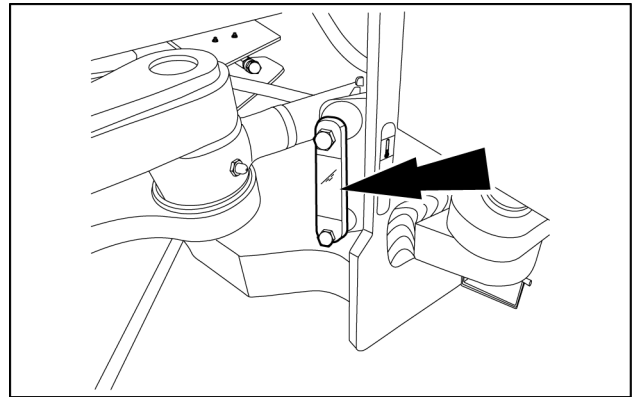

LEIL15WHL0687AB 1

The transmission oil fill is located above the transmission oil level in the sight gauge.

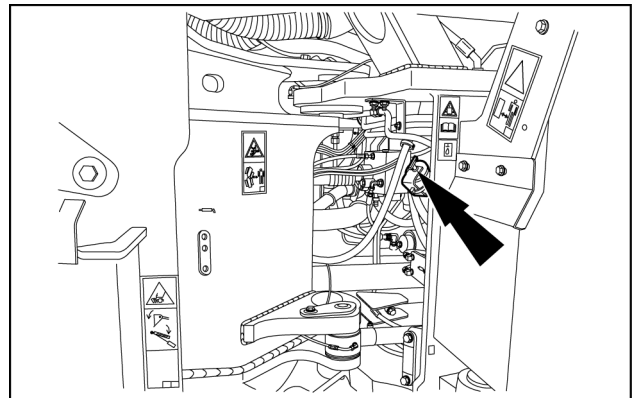

LEIL15WHL0804AB 2

Engine oil filter (Initial) - Replace

Replace the engine oil filter when the hour meter registers 100 hours for a new machine during the initial run-in period. Replace the engine oil every 500 hours thereafter or more frequently when the engine operating conditions are severe.

Prior operation:

Keep all non-authorized personnel clear of the area. Park the machine on level ground, in neutral with the parking brake applied and the attachment lowered to the ground.

NOTE: *it is recommended to change the engine oil when you replace the engine oil filter.*

1. Lower the bucket/attachment to the ground and install the transport/service link into the locked position.

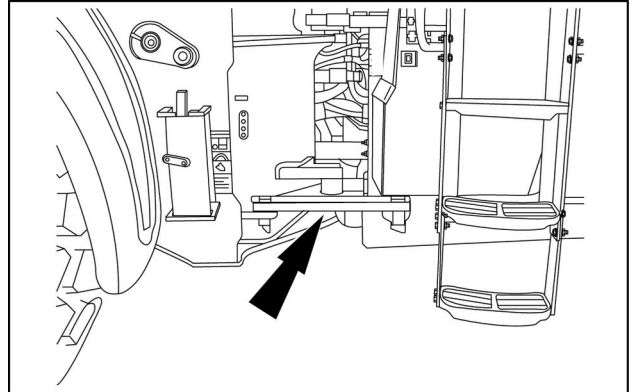

LEIL15WHL1782AA 1

2. Raise the engine hood. Locate the oil filter on the left-hand side of the machine. Clean the area around the filter of dirt and debris.
3. Turn the filter housing counterclockwise to remove. Remove and discard the filter following local environmental and waste regulations.
4. Replace the filter with a new component. Replace the housing gasket. Apply a thin layer of clean **CASE AKCELA UNITEK NO. 1™ SBL CJ-4** to the new filter gasket.

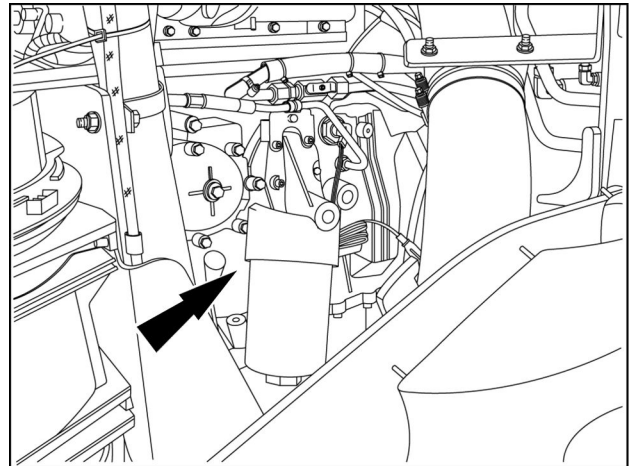

RCPH11WHL295AAH 2

NOTICE: *never use a filter wrench to install a new filter.*

5. Turn the new oil filter onto the base until the gasket makes contact with the base and then turn by hand an additional 3/4 turn.
6. Fill the engine with the proper amount of **CASE AKCELA UNITEK NO. 1™ SBL CJ-4** through the fill port (2).
7. Start the engine and run at idle speed. Check the engine oil filter and remote drain for leaks.
8. After two minutes stop the engine.
9. Wait for the engine oil to drain down for an accurate reading on the dipstick.
10. Check the dipstick (1) and add additional **CASE AKCELA UNITEK NO. 1™ SBL CJ-4**, if necessary.
11. Lower the engine hood.

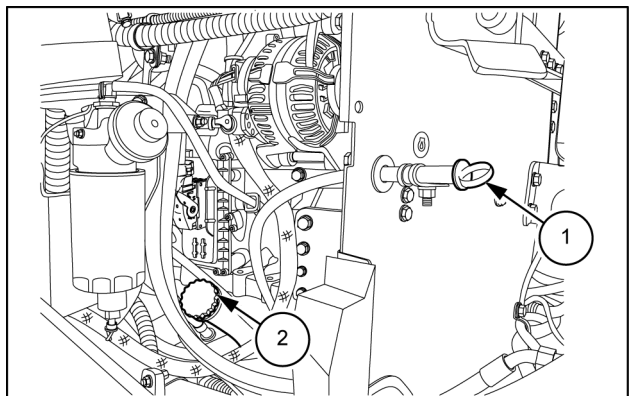

LEIL15WHL0689AB 3

Every 100 hours

Machine fittings - Grease

⚠ WARNING

Improper operation or service of this machine can result in an accident. Read and understand the **SAFETY INFORMATION** Section before you perform any maintenance, service, or repairs. Read and understand the specific service procedures for the components you plan to work with before you start servicing the machine. Failure to comply could result in death or serious injury.

W0138A

⚠ DANGER

Crushing hazard!
If you service the machine with the loader lift arms raised, always use the support strut. Remove the retaining pin and place the support strut onto the cylinder rod. Install the retaining pin into the support strut. Lower the lift arms onto the support strut. Failure to comply will result in death or serious injury.

D0084A

⚠ WARNING

Avoid injury! Always do the following before lubricating, maintaining, or servicing the machine.

1. Disengage all drives.
2. Engage parking brake.
3. Lower all attachments to the ground, or raise and engage all safety locks.
4. Shut off engine.
5. Remove key from key switch.
6. Switch off battery key, if installed.
7. Wait for all machine movement to stop.

Failure to comply could result in death or serious injury.

W0047A

Grease the articulation joint, machine grease fittings, lift arm fittings and lift arm cylinder every 100 hours of operation or sooner if conditions so require.

Prior operation:

Always have the machine on firm, level ground with the bucket/attachment on the ground. Make sure all residual pressure is relieved from the circuits before beginning maintenance.

Machine grease fittings

Service specifications	
Grease Specification	CASE AKCELA MOLY GREASE

Clean around the area to be greased before service.

NOTICE: *in severe conditions, such as immersion in water, it may be necessary to reduce the greasing service intervals.*

Wheels - Tire inflating

⚠ WARNING

Explosion hazard!

Never weld on a wheel. Welding can cause stresses that will cause a wheel to crack or break unexpectedly. Tires can separate explosively during welding. Always have a qualified tire mechanic service wheels and tires.

Failure to comply could result in death or serious injury.

W0124A

Tire service

Service specifications - Normal Work Tire Inflations		
1021G Tire type	Front pressure	Rear pressure
26.5 x 25 L3 Bias 20 Ply	3.5 bar (50 psi)	2.8 bar (40 psi)
26.5 x 25 L5 Bias 20 Ply	3.5 bar (50 psi)	2.8 bar (40 psi)
26.5 R25 L3 Radial	4.5 bar (65 psi)	3.2 bar (47 psi)
26.5 R25 L5 Radial	4.5 bar (65 psi)	3.2 bar (47 psi)

Service specifications - Normal Work Tire Inflations		
1121G Tire type	Front pressure	Rear pressure
26.5 x 25 L3 Bias 20 Ply	4.5 bar (65 psi)	3.2 bar (47 psi)
26.5 x 25 L5 Bias 20 Ply	4.5 bar (65 psi)	3.2 bar (47 psi)
26.5 R25 L3 Radial	5 bar (73 psi)	3.5 bar (51 psi)
26.5 R25 L5 Radial	5 bar (73 psi)	3.5 bar (51 psi)

NOTE: for continuous operation at maximum travel speed, consult tire manufacturer for limitations on total distance traveled per hour.

Keep all non-authorized personnel clear of the area. Park the machine on level ground, in neutral with the parking brake applied and the attachment lowered to the ground.

To add air to a tire:

1. Use an air hose with a remote shutoff valve and a self-locking air chuck. Put the tire in a restraining cage.
2. Stand BEHIND the tread of the tire and make sure ALL personnel are away from the side of the tire before you start.
3. Inflate the tire to the recommended air pressure. DO NOT inflate the tire more than the recommended pressure.

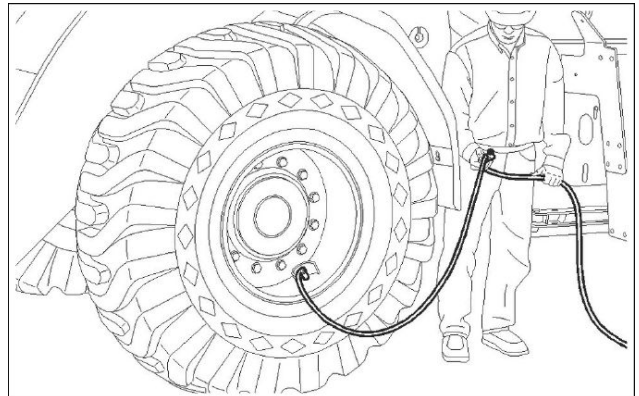

LE1L16WHL0199AA 1

Tire or rim service

Always have a qualified tire technician service the tires and rims for this machine. It is recommended that you have this technician inflate the tires. To prevent accidents, use a restraining device (tire inflation cage), correct equipment, and correct procedure.

Explosive separation of the tire (single piece rim) or the tire and / or rim parts (multi-piece rim) can cause serious injury or death.

Fuel tank sediment - Drain

⚠ WARNING

Hot liquid under pressure!

Fuel in the high pressure fuel line is still under pressure immediately after you shut down the engine. Before performing any maintenance or inspection, wait for 2 minutes after engine shutdown to allow the pressure to drop.

Failure to comply could result in death or serious injury.

W0249A

⚠ WARNING

Chemical hazard!

When handling fuel, lubricants, and other service chemicals, follow the manufacturer's instructions. Wear Personal Protective Equipment (PPE) as instructed. Do not smoke or use open flame. Collect fluids in proper containers. Obey all local and environmental regulations when disposing of chemicals.

Failure to comply could result in death or serious injury.

W0371A

Prior operation:

Keep all non-authorized personnel clear of the area. Park the machine on level ground, in neutral with the parking brake applied and the attachment lowered to the ground. Install the transport/service link into the lock position.

Drain condensation from the fuel tank when the hour meter registers 500 hours of operation or more frequently if conditions so require. The drain is on the lower rear of the machine.

1. Have a suitable container ready to collect the condensation and fuel. Dispose of the waste following local regulations.
2. Remove the cover to access the fuel tank drain.
3. Open the fuel tank drain slowly, remove the tank drain plug, and allow the condensation to flow until only fuel is discharged.
4. Turn the drain handle and close the drain. Replace the tank drain plug.

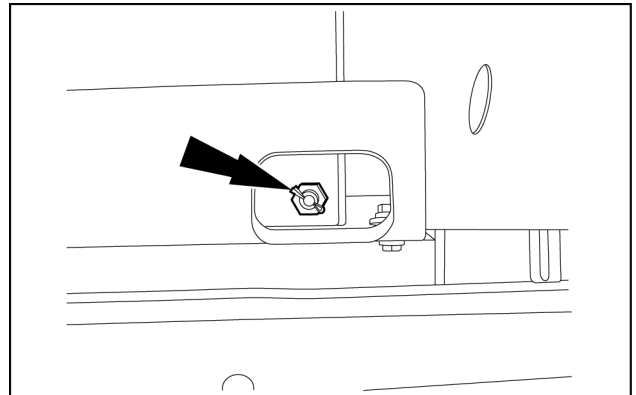

LEIL15WHL1793AB 1

4. Loosen the clamps from the breather body and remove from hose.
5. Discard appropriately and reinstall a new filter.

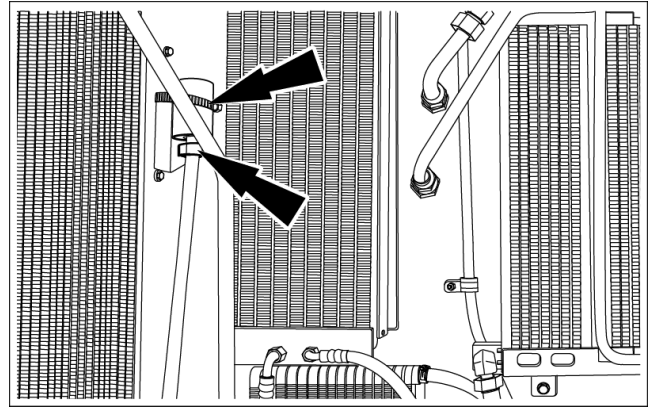

LEIL15WHL0756AB 4

4. Extract the main filter element (1) from the filter housing (2).

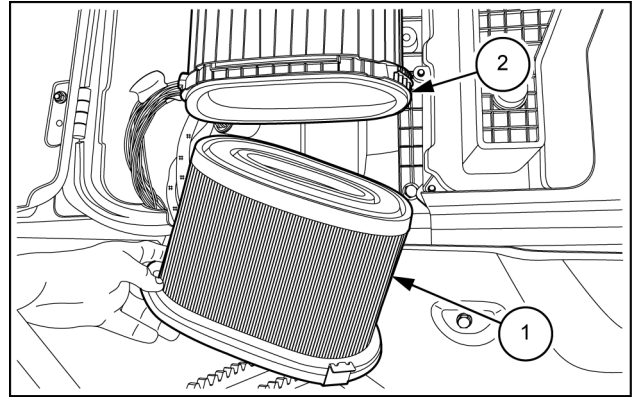

LEIL15WHL0567AB 4

5. Discard the main filter element.
6. Wipe the inside of the filter housing.
7. Install a new main filter element into the filter housing.
8. Secure the filter grid assembly to the filter housing.
9. Close the right-hand door.

Transmission breather - Cleaning

1. After changing the transmission oil and the transmission filter, locate the breather on the top of the transmission. Spin the breather a few times. Clean the breather filter, if equipped.
2. If the breather is difficult to spin, follow steps 3 and 4.
3. Remove the breather. Clean the breather with solvent and dry with compressed air.
4. Install the breather.
5. Check the oil level at the sight gauge.
6. Start the engine, and check for oil leaks around the transmission filter and the drain plug.
7. Bring the transmission oil up to working temperature, and check the level again.

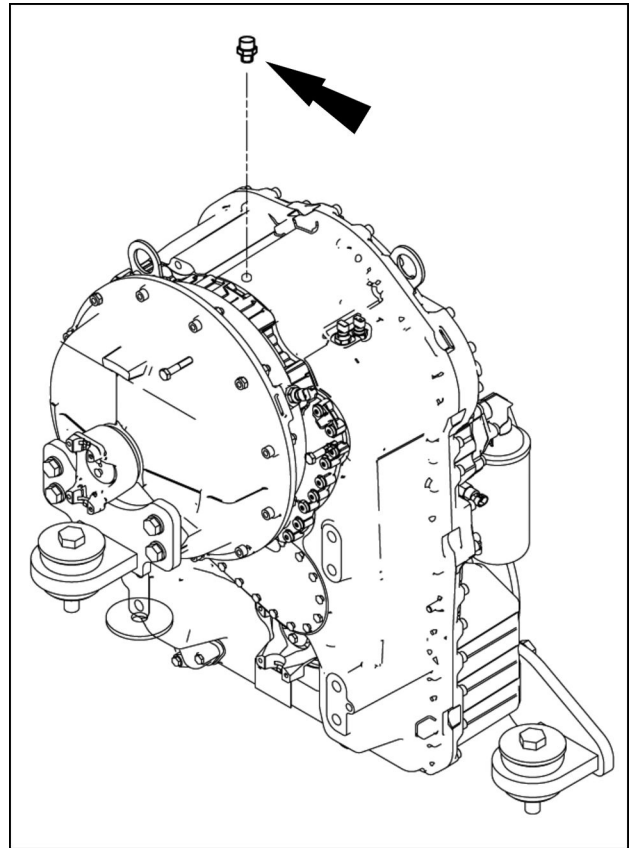

LEEN11T0309BA 1

4. Locate the engine air filter on the right-hand side of the machine.

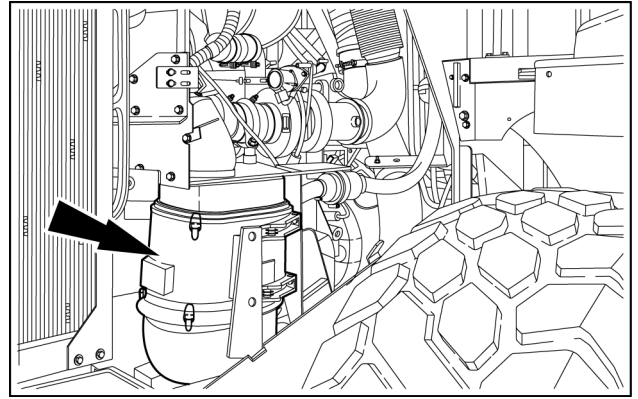

LEIL15WHL0704AB 4

5. Release the clips that secure the filter cover.
6. Remove the cover.
7. Remove the primary filter using the handle to pull the element straight out.

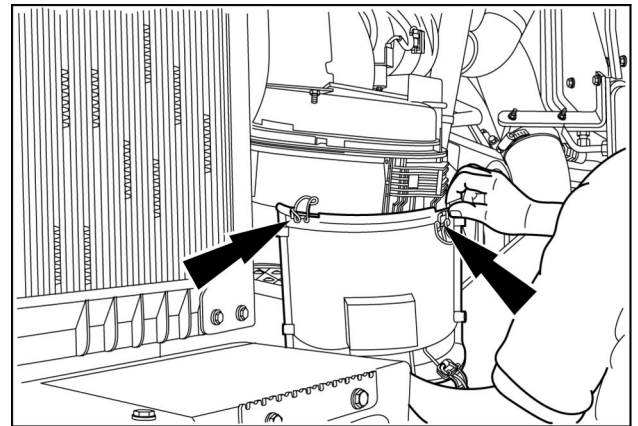

RCPH11WHL106AAH 5

8. Clean the inside of the filter housing body from dirt and debris.

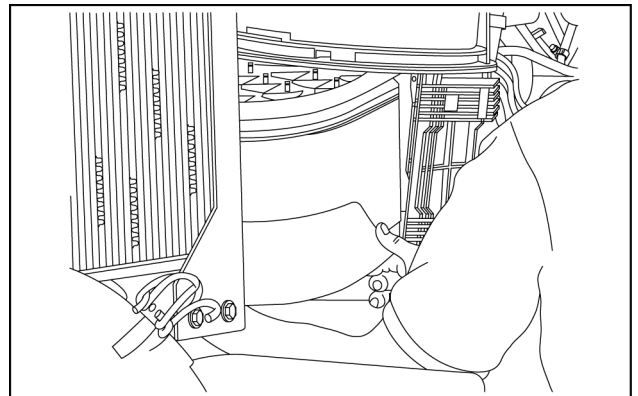

LEIL15WHL1802AA 6

9. Remove the secondary filter from the top of the housing. Use the handle and pull down and out.
10. Wipe the inside of housing. Install the new secondary filter.

NOTICE: do not reuse the secondary filter.

11. Insert the filter into the positioning slot. Seat firmly the secondary filter into the inlet housing.

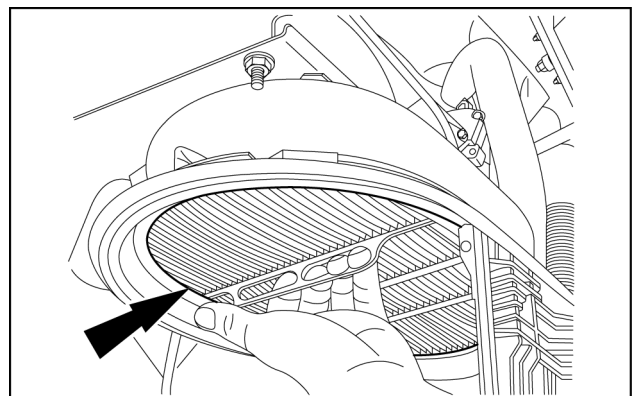

LEIL15WHL1803AB 7

Engine coolant - Change

⚠ WARNING

Burn hazard!

Hot coolant can spray and scald if you remove the radiator or deaeration tank cap while the system is hot. To remove the cap: allow the system to cool, turn the cap to the first notch, and wait for all pressure to release. Remove the cap only after all pressure has released.

Failure to comply could result in death or serious injury.

W0367A

⚠ WARNING

Rotating parts!

The engine is running. Keep clear of rotating fans and belts.

Failure to comply could result in death or serious injury.

W0275A

Drain, flush and replace the engine coolant every 4000 hours of operation or each year, whichever occurs first. Clean the system and replace the coolant if it becomes dirty or is rust colored.

Service specifications	
Type of coolant	CASE AKCELA ACTIFULL™ OT EXTENDED LIFE COOLANT
1021G Capacity	56.8 L (15.0 US gal)
1121G Capacity	56.8 L (15.0 US gal)

1. After the engine has cooled and the temperature of the coolant has reached a safe level, remove the cap.

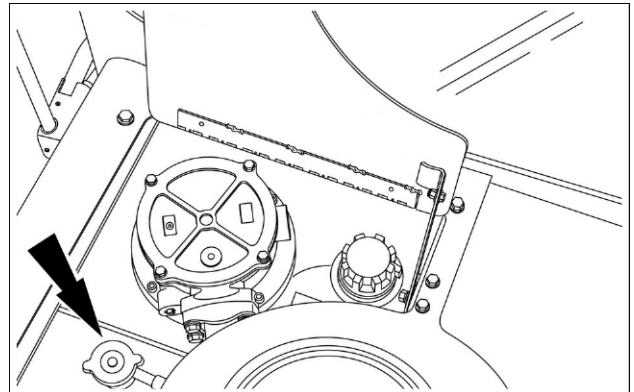

LEIL15WHL0718AB 1

2. With a suitable container of the proper capacity under the drain, open the cap by turning counterclockwise and drain the coolant from the system.
3. After all the coolant is drained, secure the drain cap.
4. Use a system cleaning product to clean and flush the system. Contact your Dealer for system cleaning products.
5. After the system has been cleaned and flushed following the cleaning product instructions, close and secure the drain valve.

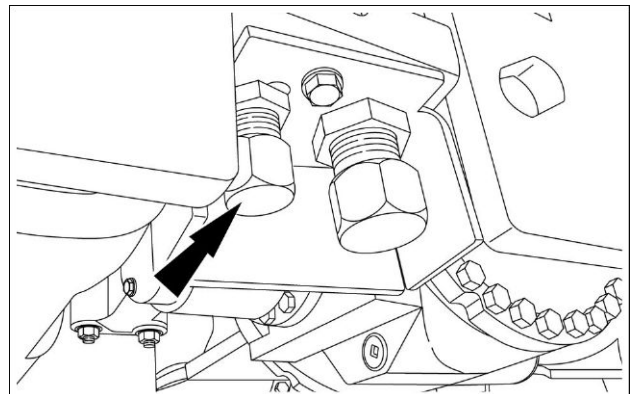

LEIL15WHL0719AB 2

Secondary steering - Check

The secondary steering system is electrically powered. This system allows you to steer the machine if the primary steering system stops working. Maintain the batteries to assure the system will function.

Check the secondary steering every **250 h** or any time electronic warnings may so indicate.

Prior operation:

Keep all non-authorized personnel clear of the area. Park the machine on hard packed level ground with enough clearance around the machine to allow complete steering from side to side. Raise the bucket approximately **500 mm (19.7 in)** above the ground.

1. Move the key switch to ON. The display turns on and shows the main menu.
2. Use the keypad on the right-hand of the display to select the key to access to the “Machine service” screens.

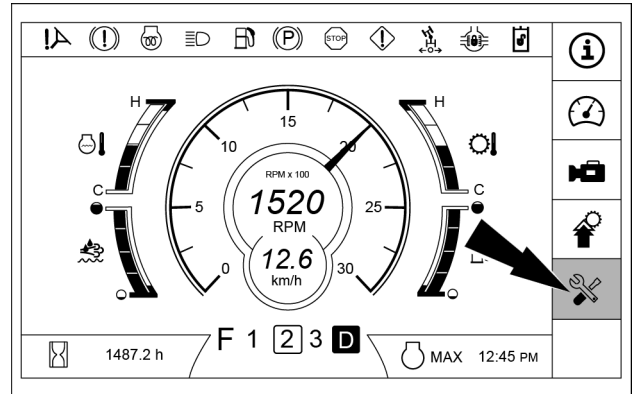

LEIL16WHL0908AA 1

3. Use the keypad on the right-hand of the display to select the key to switch to the “Calibration Settings” screens.

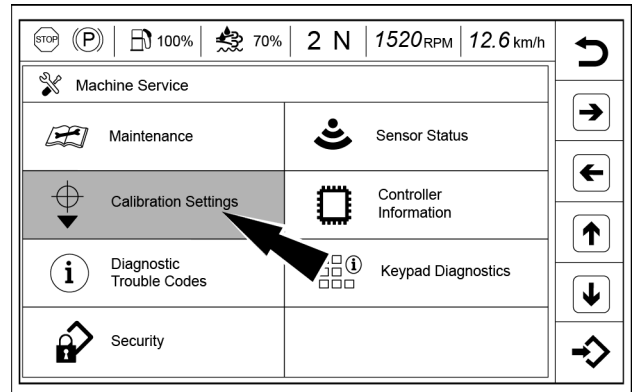

LEIL16WHL0874AA 2

4. Use the keypad on the right-hand of the display to select the “Aux Steering Pump Test” item.
5. The screen displays the conditions to be satisfied before starting the auxiliary steering pump test.
6. The key switch is already ON and engine not running. Place the transmission in NEUTRAL.
7. Use the keypad on the right-hand of the display to select “start” the test.

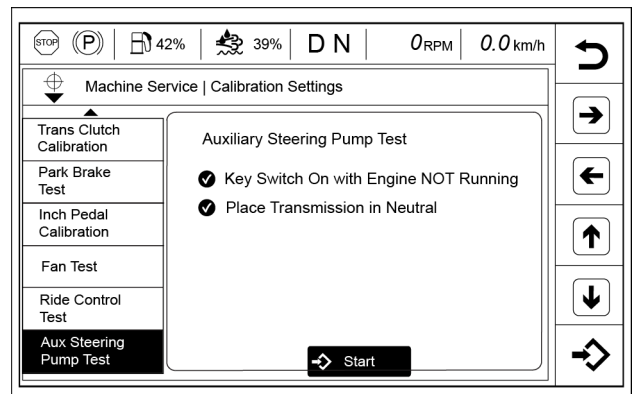

LEIL16WHL0875AA 3

Battery electrolyte level - Check

⚠ WARNING

Hazardous chemicals!

Battery electrolyte contains sulfuric acid. Contact with skin and eyes could result in severe irritation and burns. Always wear splash-proof goggles and protective clothing (gloves and aprons). Wash hands after handling.

Failure to comply could result in death or serious injury.

W0006A

⚠ WARNING

Battery acid causes burns. Batteries contain sulfuric acid.

Avoid contact with skin, eyes or clothing. Antidote (external): Flush with water. Antidote (eyes): flush with water for 15 minutes and seek medical attention immediately. Antidote (internal): Drink large quantities of water or milk. Do not induce vomiting. Seek medical attention immediately.

Failure to comply could result in death or serious injury.

W0111A

⚠ WARNING

Chemical hazard!

Battery posts, terminals, and related accessories contain lead and lead compounds. Wash hands after handling.

Failure to comply could result in death or serious injury.

W0349A

Check battery fluid level and specific gravity

Check the battery fluid level every 500 hours of operation or more often if conditions are severe. The battery fluid can decrease with high temperatures.

1. Insert a flat blade screwdriver into slots at the top of battery caps. Remove the cell caps and check the level in each battery cell. The level should be no less than **4.8 mm (0.2 in)** from the bottom of the cell. Add distilled water if necessary, then install the cell caps.

NOTE: wipe the top of the battery or use compressed air to remove dust. Use care when removing caps and do not allow dirt or contaminants to enter the battery cells.

NOTICE: continuous use of the battery with low fluid will lower battery performance.

2. If the terminals are dirty, wash with warm water. Reinstall the terminals, apply grease or spray rust preventive solution to create good connections.
3. If the terminal is oxidized, polish it with a wire brush or emery paper.

NOTE: measure the specific gravity of battery fluid with a gravimeter. The measured value will vary depending on the ambient temperature.

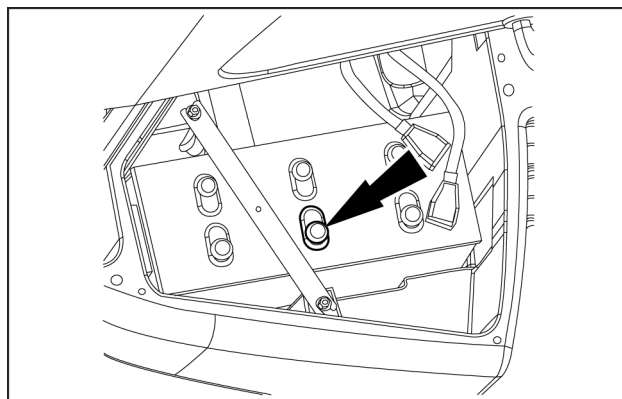

LEIL15WHL1807AB 1

Lights - Replace

1. Front work lights
2. Rear work lights
3. Driving lights
4. Tail lights

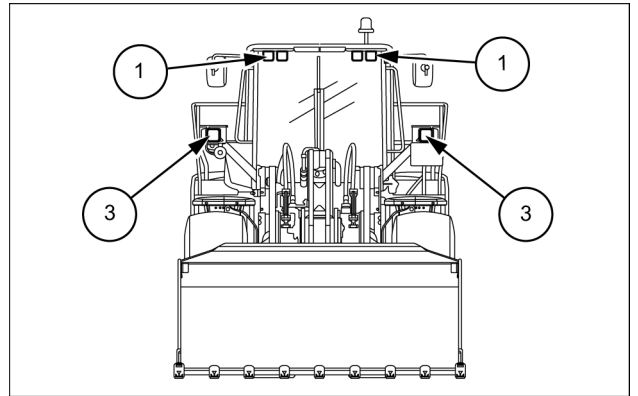

LEIL16WHL1605AB 1

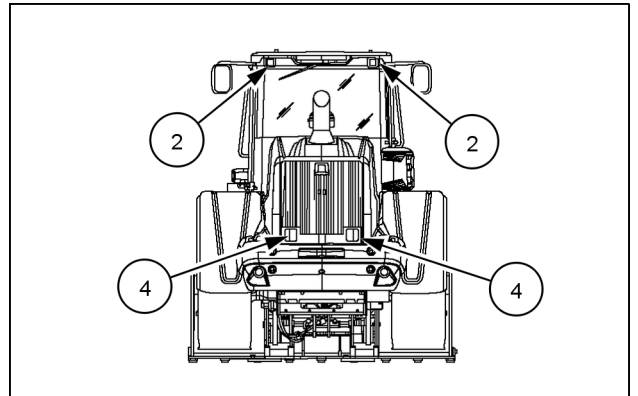

LEIL16WHL0552AA 2

Work lights (halogen)

To replace the work lights, remove the hardware fixing the light to the cab frame. Disconnect the push-on connector, and replace the lamp assembly. Reconnect the push-on connector, making certain the connection is firmly in place. Reinstall the lamp assembly to the cab frame.

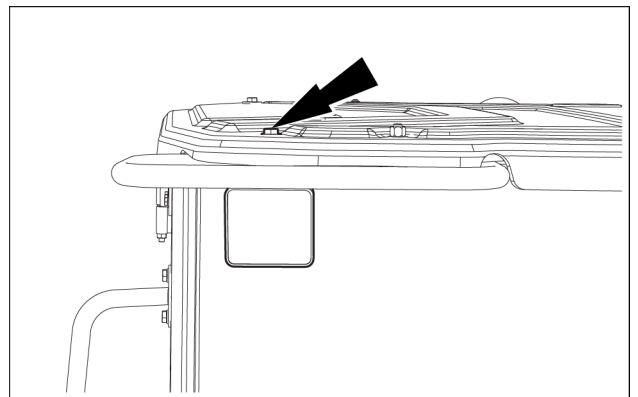

LEIL16WHL1611AB 3

1021G Cylinder Specifications

Lift cylinder	
Bore diameter	177.8 mm (7.00 in)
Rod diameter	114.3 mm (4.50 in)
Stroke	780.6 mm (30.73 in)
Steer cylinder	
Bore diameter	88.71 mm (3.493 in)
Rod diameter	50.8 mm (2.00 in)
Stroke	518.0 mm (20.39 in)
Dump cylinder	
Bore diameter	203.2 mm (8.00 in)
Rod diameter	127.0 mm (5.00 in)
Stroke	581.9 mm (22.91 in)

Instrumentation Gauges

Speedometer	Engine Coolant Temperature (ECT)	Gear position
Tachometer	Hydraulic oil temperature	Transmission modes
Hourmeter	Transmission oil temperature	Travel selected (FNR)
Fuel level	DEF level	Work mode

Operator Environment

ROPS cab with heater	Key start	Articulated power steering with tilt
Adjustable suspension seat	Single lever 2-spool loader control	Cup holder
Coat hook	Interior rear view mirror	Single brake pedal
Storage tray	Dome light	Front and rear windshield washers
Exterior rear view mirrors	Front (intermittent) and rear wipers	52 mm (2 in) retractable seat belt
Right and left steps/platforms	Fire extinguisher bracket	

Hydraulic Specifications

Pump 1	Closed centered pressure/flow compensated
Variable displacement	100.0 cm³/rev (6.1 in³/rev) 190 l/min (50.2 US gpm) @ 2000 RPM
Pump 2	Closed centered pressure/flow compensated
Variable displacement	85.0 cm³/rev (5.19 in³/rev) 162 l/min (42.8 US gpm) @ 2000 RPM
Loader auxiliary steering	hydraulic orbital center-pivot articulating w/on-demand oil flow
Filtration	10-micron, full flow replaceable cartridges on return line, condition indicator light for filter

1121G Model**1121G Engine Specifications**

Model	FPT F2CFE614F, Tier 4b certified
-------	----------------------------------

8 - SPECIFICATIONS

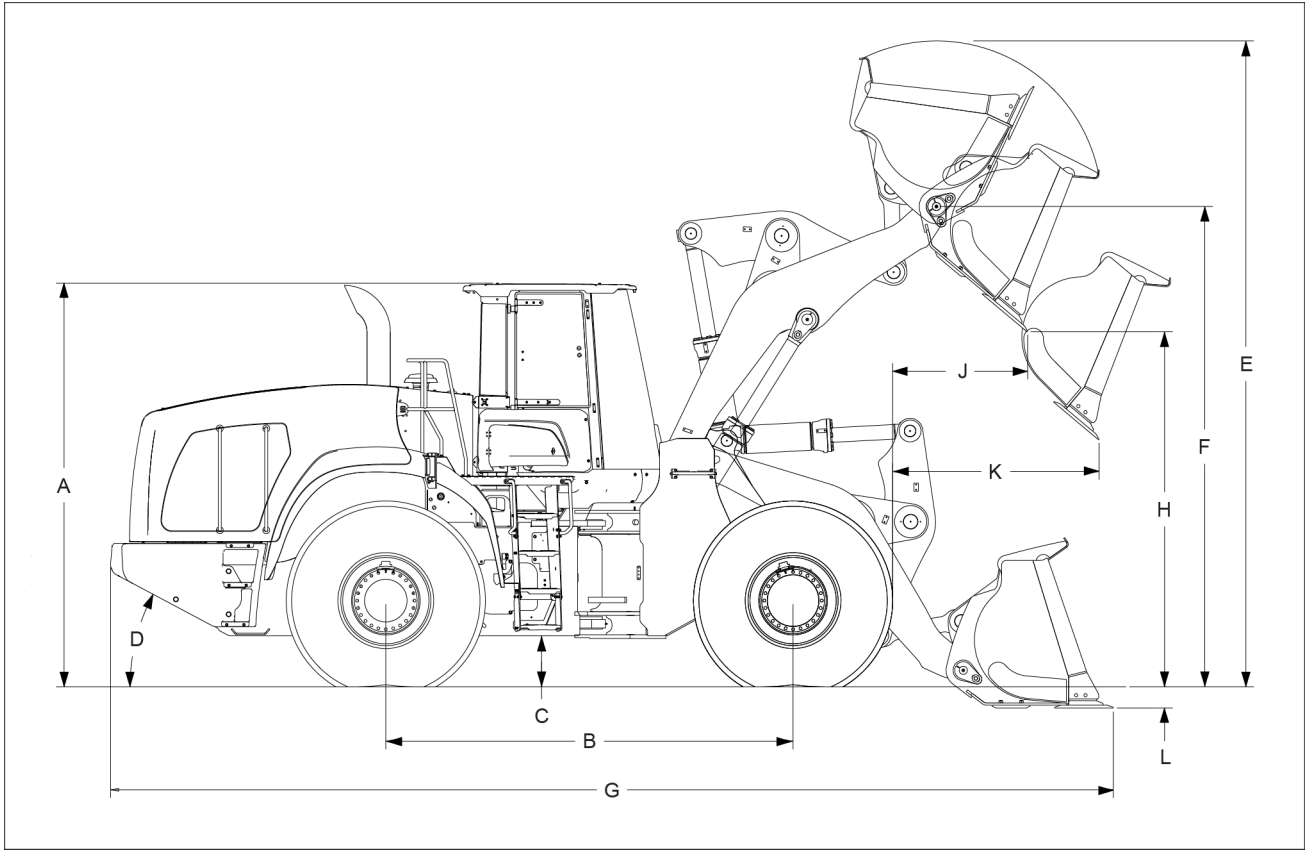

LEIL16WHL0674FA 6

1121G Z-Bar Specifications - 4.8 m³ (6.25 yd³) Blade / 4.7 m³ (6.1 yd³) Teeth - Pin On

	Bucket with Bolt-on Edge	Bucket with Teeth
Bucket Specifications		
Capacity (heaped)	4.78 m³ (6.25 yd³)	4.66 m³ (6.10 yd³)
Bucket width (maximum outer)	3195 mm (125.8 in)	3223 mm (126.9 in)
Dimensional Outline Specifications		
A (top of cab height)	3576 mm (140.8 in)	3576 mm (140.8 in)
B (wheelbase)	3550 mm (139.8 in)	3550 mm (139.8 in)
C (ground clearance)	437 mm (17.2 in)	437 mm (17.2 in)
D (rear angle of departure)	23°	23°
Overall width with bucket guard	2978 mm (117.2 in)	2978 mm (117.2 in)
Centerline tread width	2300 mm (90.6 in)	2300 mm (90.6 in)
Turning radius (outside of tires)	6366 mm (250.6 in)	6366 mm (250.6 in)
Turning angle from center	40°	40°
Total turning angle	80°	80°
E (fully raised with spillguard)	6147 mm (242.0 in)	6147 mm (242.0 in)
F (hinge pin - fully raised)	4449 mm (175.2 in)	4449 mm (175.2 in)
G (overall - bucket level on ground)	9172 mm (361.1 in)	9354 mm (368.3 in)
H (dump - fully raised, 45° dump)	3209 mm (126.3 in)	3090 mm (121.7 in)
J (reach - fully raised, 45° dump)	1273 mm (50.1 in)	1406 mm (55.4 in)
K (reach - 2.13 m (7.0 ft), 45° dump)	2043 mm (80.4 in)	2121 mm (83.5 in)
L (dig depth)	111 mm (4.4 in)	116 mm (4.6 in)
ISO Load Specifications		
Operating Weight (without load)	27964 kg (61650 lb)	27962 kg (61646 lb)
Operating load	8721 kg (19227 lb)	8775 kg (19345 lb)
Tipping load		
Machine straight	22076 kg (48670 lb)	22214 kg (48973 lb)
40° turn	17443 kg (38454 lb)	17550 kg (38691 lb)

CLICK HERE TO **DOWNLOAD** THE COMPLETE MANUAL

- Thank you very much for reading the preview of the manual.
- You can download the complete manual from: www.heydownloads.com by clicking the link below



- Please note: If there is no response to CLICKING the link, please download this PDF first and then click on it.

CLICK HERE TO **DOWNLOAD** THE COMPLETE MANUAL