

X 331
X 331E
X 334



Bobcat®

Operation & Maintenance Manual

S/N 512915200 & Above
S/N 517711001 & Above
S/N 516711001 & Above

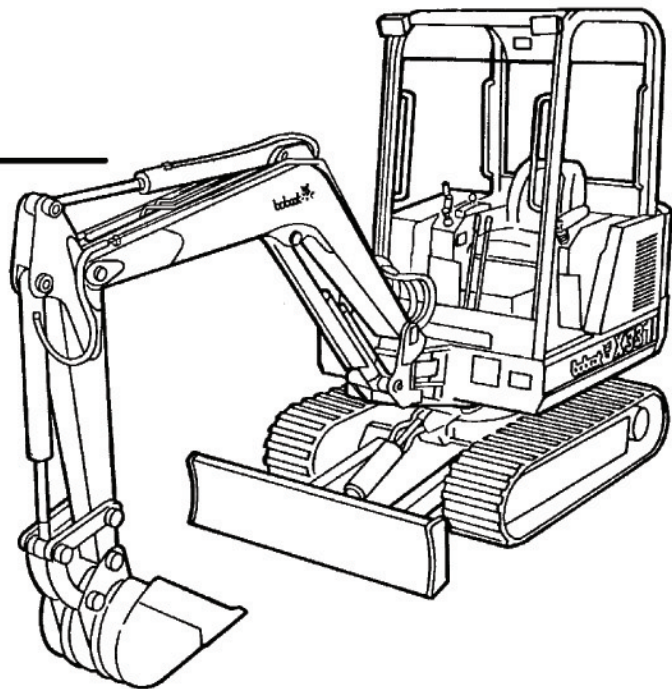

Doosan purchased Bobcat Company from Ingersoll-Rand Company in 2007. Any reference to Ingersoll-Rand Company or use of trademarks, service marks, logos, or other proprietary identifying marks belonging to Ingersoll-Rand Company in this manual is historical or nominative in nature, and is not meant to suggest a current affiliation between Ingersoll-Rand Company and Bobcat Company or the products of either.



CLICK HERE TO **DOWNLOAD** THE COMPLETE MANUAL

- Thank you very much for reading the preview of the manual.
- You can download the complete manual from: www.heydownloads.com by clicking the link below



- Please note: If there is no response to CLICKING the link, please download this PDF first and then click on it.

CLICK HERE TO **DOWNLOAD** THE COMPLETE MANUAL

SAFETY

SAFETY INSTRUCTIONS	ix, x
FIRE PREVENTION	xi
MACHINE SIGNS (DECALS)	xii, xiii

SAFETY

INSTRUMENT PANEL

The instrument panel has the following instruments:

PREHEAT INDICATOR LIGHT – (Item 1) [A] – When turning the key switch to the PREHEAT position, the light comes ON, showing the glow plugs are heating.

ENGINE CHARGING LIGHT – (Item 2) [A] – When the alternator output is low the light will come on.

HYDRAULIC FILTER/ FLUID LIGHT – (Item 3) [A] – When the hydraulic filter is plugged or the hydraulic fluid is overheated, the light comes ON and the audible alarm sounds. Stop the engine.

ENGINE OIL LIGHT – (Item 4) [A] – When the engine oil pressure is low, the light comes ON and audible alarm sounds. STOP the engine.

LOW FUEL INDICATOR LIGHT – (Item 5) [A] – When fuel level is low (approximately 2.5 gals. [9,3 L.]), the light comes ON. Add fuel.

FUEL GAUGE – (Item 6) [A] – Shows the amount of the fuel in the tank.

ENGINE TEMPERATURE GAUGE – (Item 7) [A] – Shows engine coolant temperature. Audible alarm sounds and the warning light (Item 8) [A] comes ON when temperature reaches 230°F. (110°C.). Stop the engine.

NOTE: To check oil pressure and hydraulic system lights, turn the key to the ON position. The hydraulic system light will turn off in 10 seconds. The oil pressure light will stay on and the warning buzzer will continue to be activated until either the key switch is turned to the off position or the engine is started.

The hourmeter (Item 1) [B] is located inside the engine compartment.

KEY SWITCH

The key switch has the following functions [C]:

- A. Key switch is OFF, and the engine stops
- B. PREHEAT position – Hold switch in this position to activate the glow plugs for starting in cold weather. See Decal (Item 1) [C] for glow plugs heating times and also Page 23.
- C. START the engine.
- D. ON (run) position – When the engine is running release the key and this position is obtained automatically. The fuel gauge and temperature gauge are illuminated when the key switch is in the on (run) position.

NOTE: Always turn key switch and all accessories to OFF position after the engine is stopped or battery will discharge. Audible alarm will sound if the key is in the ON position with the engine stopped.

See Pages 22 and 23 for the starting procedure.

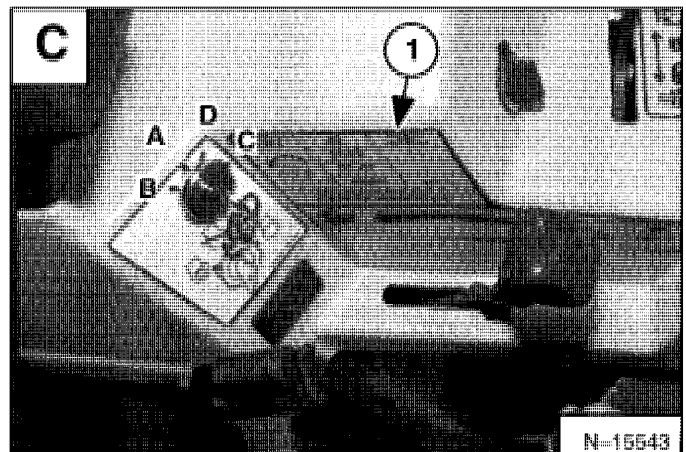
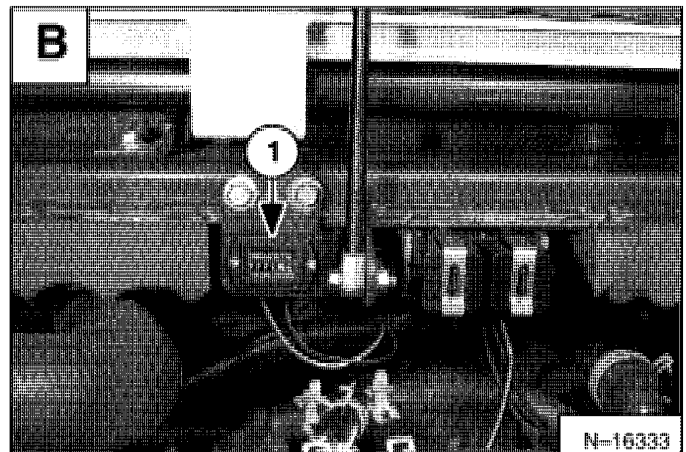
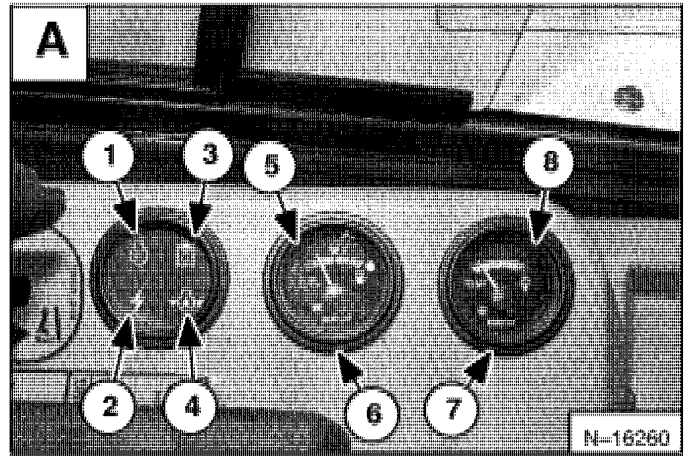

AUXILIARY HYDRAULIC PEDAL

Quick Couplers

Current excavators and attachments have flush faced couplers (Item 1) [A].

! WARNING

AVOID BURNS

Hydraulic fluid, tubes, fittings and quick couplers can get hot when running machine and attachments. Be careful when connecting and disconnecting quick couplers.

W-2220-0396

To Connect: Remove any dirt or debris from the surface of both the male and female coupler halves, and from the outside diameter of the male coupler. Visually check the couplers for corroding, cracking, damage, or excessive wear, if any of these conditions exist, the coupler(s) (Item 1) [A] must be replaced.

Install the male half coupler into the female half coupler. Full connection is made when the ball release sleeve slides forward on the female coupler and the sleeve is rotated.

Install the male half coupler into the female half coupler. Full connection is made when the ball release sleeve slides forward on the female coupler and the sleeve is rotated so that the locking pins (Item 1) [B] and the groove (Item 2) [B] do NOT align (Locked Position). This will prevent accidental disconnection.

NOTE: If the locking pins and grooves (Item 1) [C] are aligned, accidental disconnection is possible.

To Disconnect: Rotate the ball release sleeve so that the grooves (Item 1) [C] are aligned with the pins (Item 2) [C] in the female coupler.

Hold the male coupler. Retract the sleeve on the female coupler until the couplers disconnect.

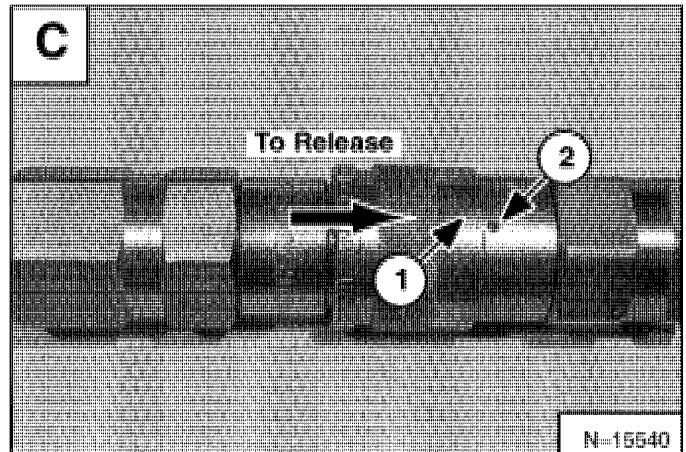
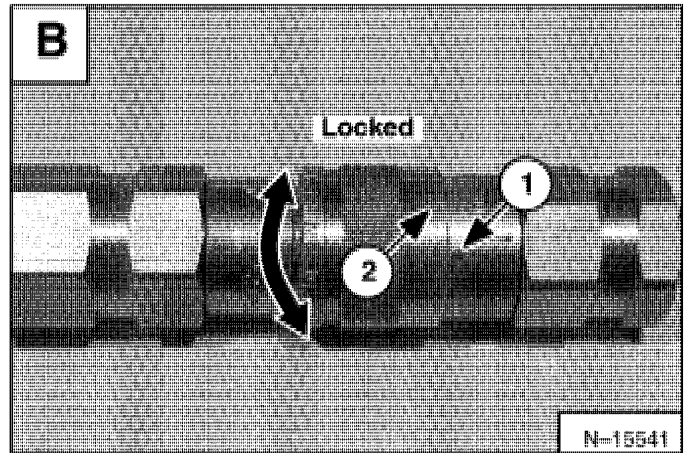
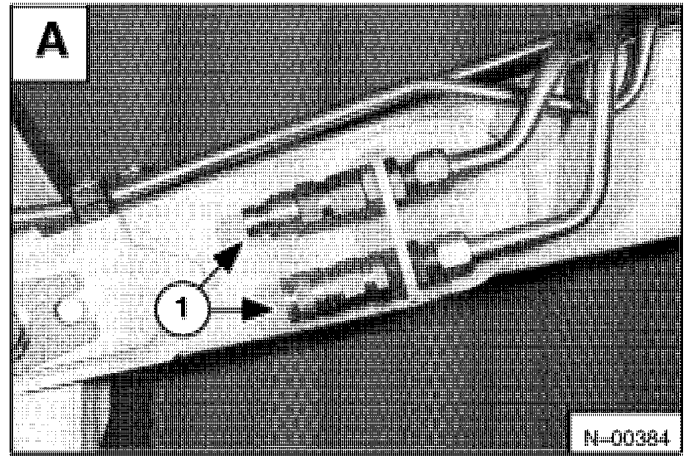

STARTING THE ENGINE (Cont'd)

! WARNING

AVOID INJURY OR DEATH

When an engine is running in an enclosed area, fresh air must be added to avoid concentration of exhaust fumes. If the engine is stationary, vent the exhaust outside. Exhaust fumes contain odorless, invisible gases which can kill without warning.

W-2050-1285

- Engines can have hot parts and hot exhaust gas. Keep flammable material away.
- Do not use machines in atmosphere containing explosive gas.

W-2051-1086

Cold Temperature Starting Procedure

Use the following procedure to make starting easier:

- Replace the engine oil with the correct type and viscosity for the anticipated starting temperature. (See *ENGINE OIL SPECIFICATIONS* Page 92.)
- Make sure the battery is fully charged.

NOTE: If the battery is discharged (but not frozen) a booster battery can be used to jump start the excavator. (See Page 49.)

Install an engine heater.

Follow the steps under *Normal Starting Procedure* and repeat the steps below until engine starts:

! WARNING

Do not use ether with glow plugs (preheat systems). Explosion can result which can cause injury or death.

W-2071-1285

Push the speed control lever fully forward to the high idle position [A].

Turn the key to PREHEAT position (Item 1) [B], the light will come on. Preheat the engine as shown in the decal [C] located on the right console.

Turn the key to START position (Item 2) [B] and start the engine.

Release the key, and it will return to the (ON) run position (Item 3) [B].

When the engine speed increases, move the speed control lever immediately to the low idle position [A].

Turn the key to the OFF position (Item 4) [B] to stop the engine.

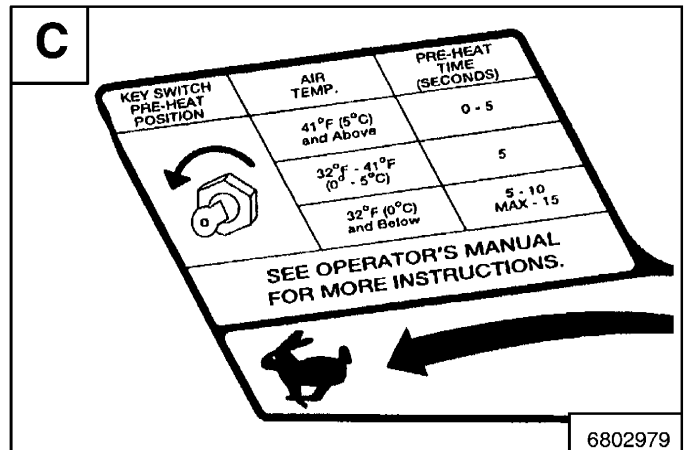
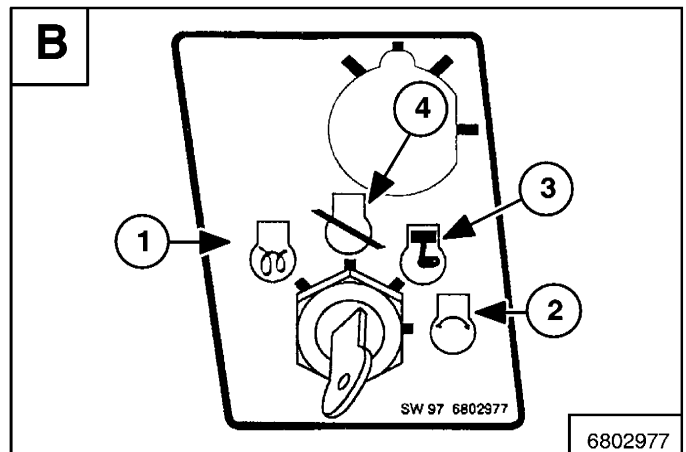
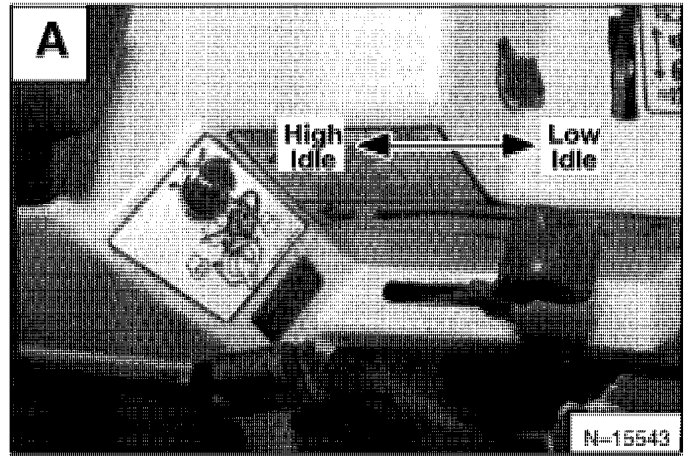

IMPORTANT

Do not engage the starter for longer than 15 seconds at a time. Longer use can damage the starter by over heating. Cool the starter for one minute between uses.

I-2034-0284

CLICK HERE TO **DOWNLOAD** THE COMPLETE MANUAL

- Thank you very much for reading the preview of the manual.
- You can download the complete manual from: www.heydownloads.com by clicking the link below



- Please note: If there is no response to CLICKING the link, please download this PDF first and then click on it.

CLICK HERE TO **DOWNLOAD** THE COMPLETE MANUAL

OPERATING PROCEDURE (Cont'd)

Operating In Water

When operating in water or crossing streams, first check the soil conditions, depth and flow of the water. Never operate in water higher than the bottom of the swing circle [A].

NOTE: Be careful when crossing streams or operating in water, so water does not flood the engine compartment causing engine damage.

Mud and water should be removed from the machine before parking. If possible, park the machine on boards or concrete to prevent the track or undercarriage from freezing to the ground and preventing machine movement.

Properly grease the Excavator when it has been operated or immersed in water for a period of time.

Water must be removed from the cylinder rods. If water freezes to the cylinder rod, the cylinder seals can be damaged when the rod is retracted.

PARKING THE HYDRAULIC EXCAVATOR

Stop the machine on level ground. Lower the work equipment and the blade to the ground.

Push the speed control (Item 1) [B] lever to the low idle position.

Run the engine at idle speed for about five minutes to allow it to cool.

Turn the key switch (Item 2) [B] to the OFF position.

Disconnect the seat belt. Remove the key from the switch to prevent operation of machine by unauthorized personnel.

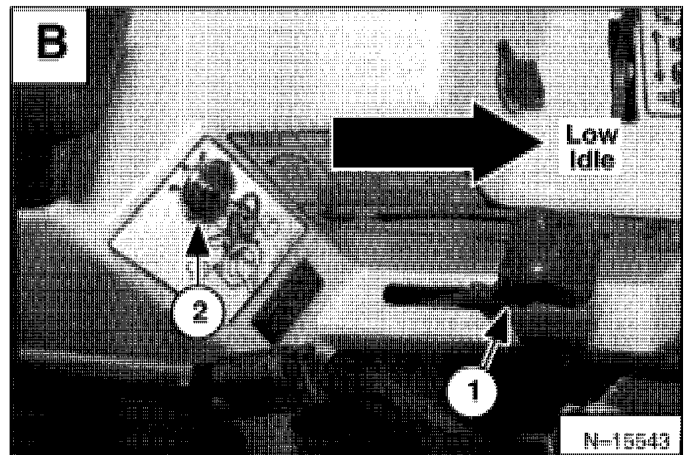
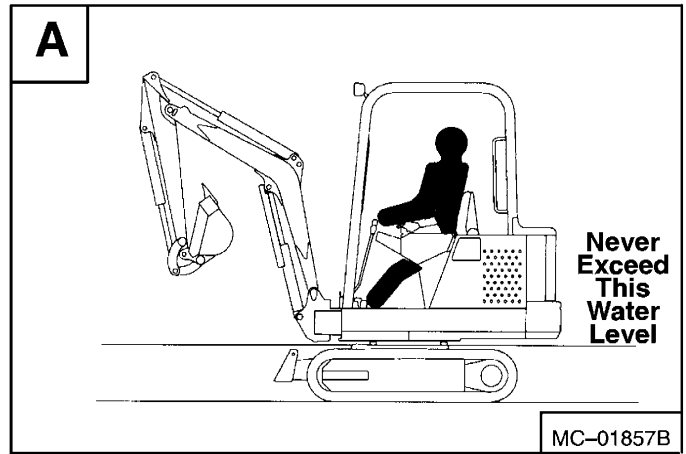

FUEL SYSTEM (Cont'd)

Fuel System Maintenance

See the *SERVICE SCHEDULE* Page 39 for the correct service intervals.

To remove water and sediment from the fuel tank, turn the upperstructure until the fuel tank is centered between the rear tracks.

Open the drain valve (Item 1) **[A]** at the bottom of the fuel tank.

Drain contaminated fuel into a container.

Removing Air From The Fuel System

After replacing the fuel filter or when the fuel tank has run out of fuel, the air must be removed from the fuel system before starting the engine.

Open the vent (Item 1) **[B]** on the fuel filter housing.

Operate the hand pump (priming bulb) (Item 1) **[C]** until the fuel flows from the vent with no air bubbles.

Tighten the vent.

Start the engine. It may be necessary to open the vent (Item 2) **[C]** at the fuel injection pump briefly until the engine runs smoothly.

Fuel Specifications

Use only clean, high quality diesel fuel, Grade No. 2 or Grade No.1.

The following is suggested blending guideline which should prevent fuel gelling problems.

Temp. F°	No. 2	No. 1
+15°(9°)	100%	0%
Down to -20° (-29°)	50%	50%
Below -20° (-29°)	0%	100%

For local recommendations, the operator can contact his fuel supplier.

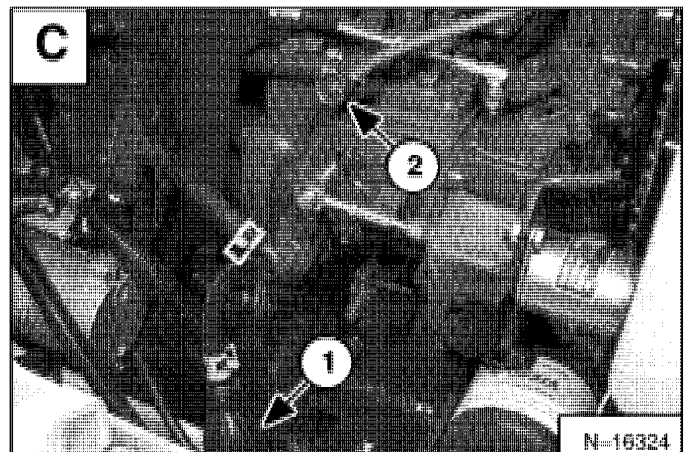
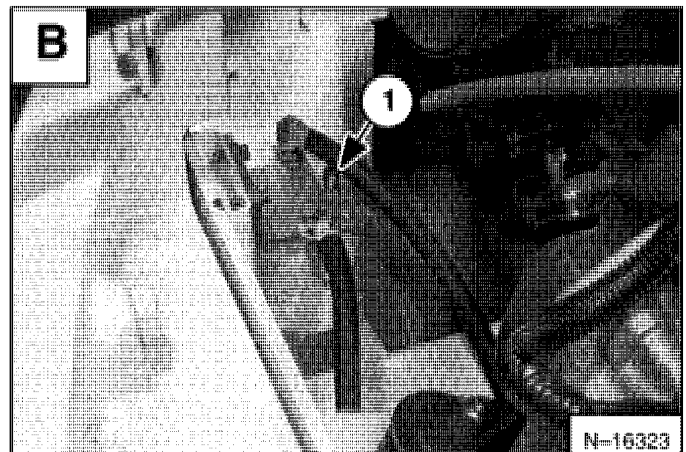
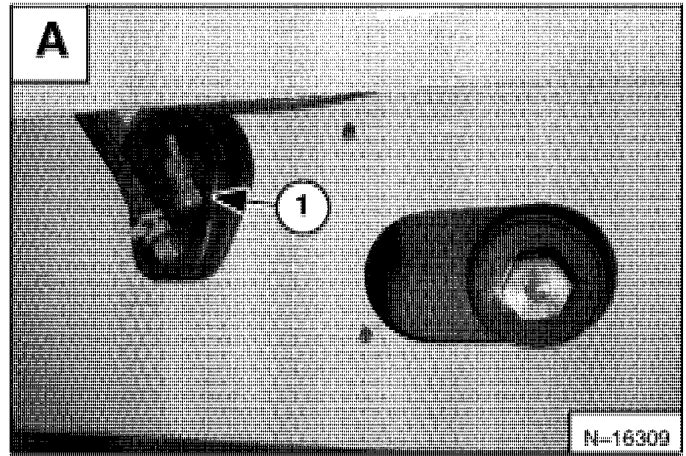

!

WARNING

Always clean up spilled fuel or oil. Keep heat, flames, sparks or lighted tobacco away from fuel and oil. Failure to use care around combustibles can cause explosion or fire which can result in injury or death.

W-2103-1285

SPARK ARRESTOR MUFFLER

See the *SERVICE SCHEDULE* Page 39 for the correct service interval.

Do not operate the excavator with a defective exhaust system.

IMPORTANT

This excavator is factory equipped with a U.S.D.A. Forestry Service approved spark arrestor muffler. It is necessary to do maintenance on this spark arrestor muffler to keep it in working condition. The spark arrestor muffler must be serviced by dumping the spark chamber every 100 hours of operation.

If this machine is operated on flammable forest, brush or grass covered land, it must be equipped with a spark arrestor attached to the exhaust system and maintained in working order. Failure to do so will be in violation of California State Law, Section 4442 PRC.

Make reference to local laws and regulations for spark arrestor requirements.

I-2061-0195

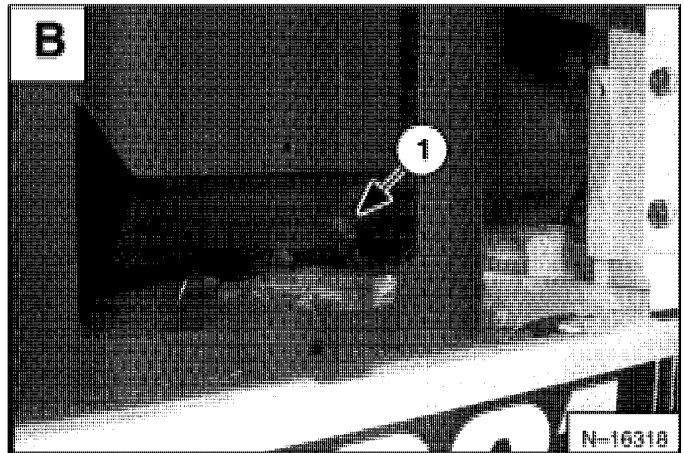
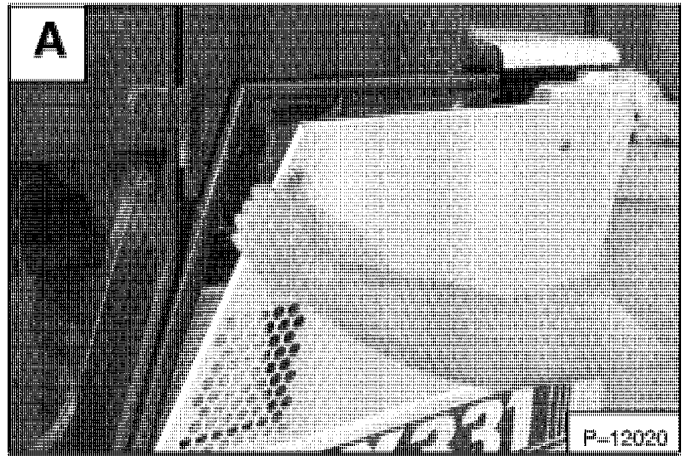

Stop the engine. Open the engine cover.

Using the start key, unlock and remove the left side cover [A].

Remove the plug (Item 1) [B] from the bottom of the muffler.

! WARNING

When the engine is running during service, the steering levers must be in neutral.

Failure to do so can cause injury or death.

W-2203-0595

Start the engine and run for about ten seconds while a second person, wearing safety glasses, holds a piece of wood over the outlet of the muffler. (The carbon deposits will be forced out of the muffler plug hole.)

Stop the engine. Install and tighten the plug.

Close the engine cover.

! WARNING

When an engine is running in an enclosed area, fresh air must be added to avoid concentration of exhaust fumes. If the engine is stationary, vent the exhaust outside. Exhaust fumes contain odorless, invisible gases which can kill without warning.

W-2050-1285

Stop engine and allow the muffler to cool before cleaning the spark chamber. Wear safety glasses or goggles. Failure to obey can cause serious injury.

W-2011-1285

Never use machine in atmosphere with explosive dust or gases or where exhaust can contact flammable material. Failure to obey warnings can cause injury or death.

W-2068-1285

MACHINE SIGN TRANSLATIONS

WARNING (6804231)	65
LIFT CAPACITY CHART (6806615) 331 w/o counterweights	66
LIFT CAPACITY CHART (6805625) 331 w/counterweights	68
LIFT CAPACITY CHART (6804687) 331E (or 331/334 if equipped with extendable arm)	70
LIFT CAPACITY CHART (6806616) 334 w/o counterweights or 331 equipped w/long arm w/o counterweights	72
LIFT CAPACITY CHART (6805626) 334 w/counterweights or 331 equipped w/long arm and w/counterweights	74
SERVICE SCHEDULE (6804326)	76
WARNING (6804230)	78
WARNING (6577754, 6804114, 6804232 & 6804233)	79

**MACHINE SIGN
TRANSLATIONS**



AVERTISSEMENT

TOUTE SURCHARGE RISQUE DE FAIRE BASCULER L'EXCAVATRICE, PROVOQUANT DES BLESSURES GRAVES OU MORTELLES.

- Ne tentez pas de lever ni de maintenir des charges dont le poids dépasse ces valeurs nominales au-delà de la portée et de la hauteur spécifiées.
- La charge nominale totale est indiquée. Pour déterminer la charge nette pouvant être levée, déduisez le poids de tous les dispositifs de levage.



EXCAVATRICE MODÈLE 334

LONGUEUR, FLÈCHE: 2400 mm (94.5 po)
 LONGUEUR, BRAS DE
 GODET: 1500 mm (59.1 po)
 CONTREPOIDS: 208.5 kg (459 lb)
 X-CHANGE 24.9 kg (55 lbs.)
 GODET STANDARD: 609 mm (24.0 po)
 97.5 kg (215 lbs)

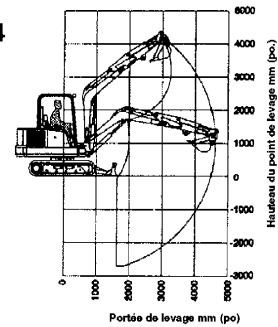

PRESSION, CIRCUIT
 DE SERVICE - 172 bar (2500 psi)
 DE MAINTIEN - 203 bar (2950 psi)

Donde corresponde, las especificaciones se ajustan a las normas ISO. Las especificaciones están sujetas a cambios sin previo aviso.
 El punto de elevación es el punto de articulación del cucharón con un cucharón estándar instalado y el cilindro del cucharón totalmente extendido.

HAUTEUR DE LEVÉE mm (po.)	CAPACITÉ DE LEVAGE NOMINALE AU-DESSUS DE LA LAME, LAME ABAISSÉ-kg (lb)				CAPACITÉ DE LEVAGE NOMINALE AU-DESSUS DE LA LAME, LAME levÉE-kg (lb)				CAPACITÉ DE LEVAGE NOMINALE AU-DESSUS DE DU CÔTÉ, LAME LEVÉE-kg (lb)			
	RAYON DE LEVÉE				RAYON DE LEVÉE				RAYON DE LEVÉE			
	2000 (78.7)	3000 (118.1)	4000 (157.5)	MAX.	2000 (78.7)	3000 (118.1)	4000 (157.5)	MAX.	2000 (78.7)	3000 (118.1)	4000 (157.5)	MAX.
3000 (118.1)				329* (726)				319* (703)				350* (772)
2000 (78.7)		413* (911)	401* (884)	410* (903)		392* (864)	364* (802)	248 (548)		419* (923)	316 (696)	262 (578)
1000 (39.4)	1217* (2684)	623* (1373)	470* (1037)	435* (960)	1124* (2478)	502 (1108)	331 (730)	242 (534)	856 (1887)	486 (1072)	290 (640)	243 (536)
AU SOL	1385* (3054)	792* (1747)	573* (1263)	520* (1147)	796 (1756)	480 (1058)	300 (661)	286 (630)	711 (1568)	437 (965)	291 (643)	257 (566)
-1000 (-39.4)	1460* (3219)	887* (1956)		655* (1445)	737 (1626)	497 (1097)		321 (707)	762 (1681)	444 (979)		309 (680)

40421

* Capacité de levage hydraulique nominale

SW 09 6806616

HYDRAULIC EXCAVATOR SPECIFICATIONS

- All dimensions are shown in inches. Respective metric dimensions are given in millimeters enclosed by parentheses.
- Where applicable, specifications conform to SAE standards. Specifications are subject to change without notice.

331 (S/N 512915200 & Above)

Machine Dimensions

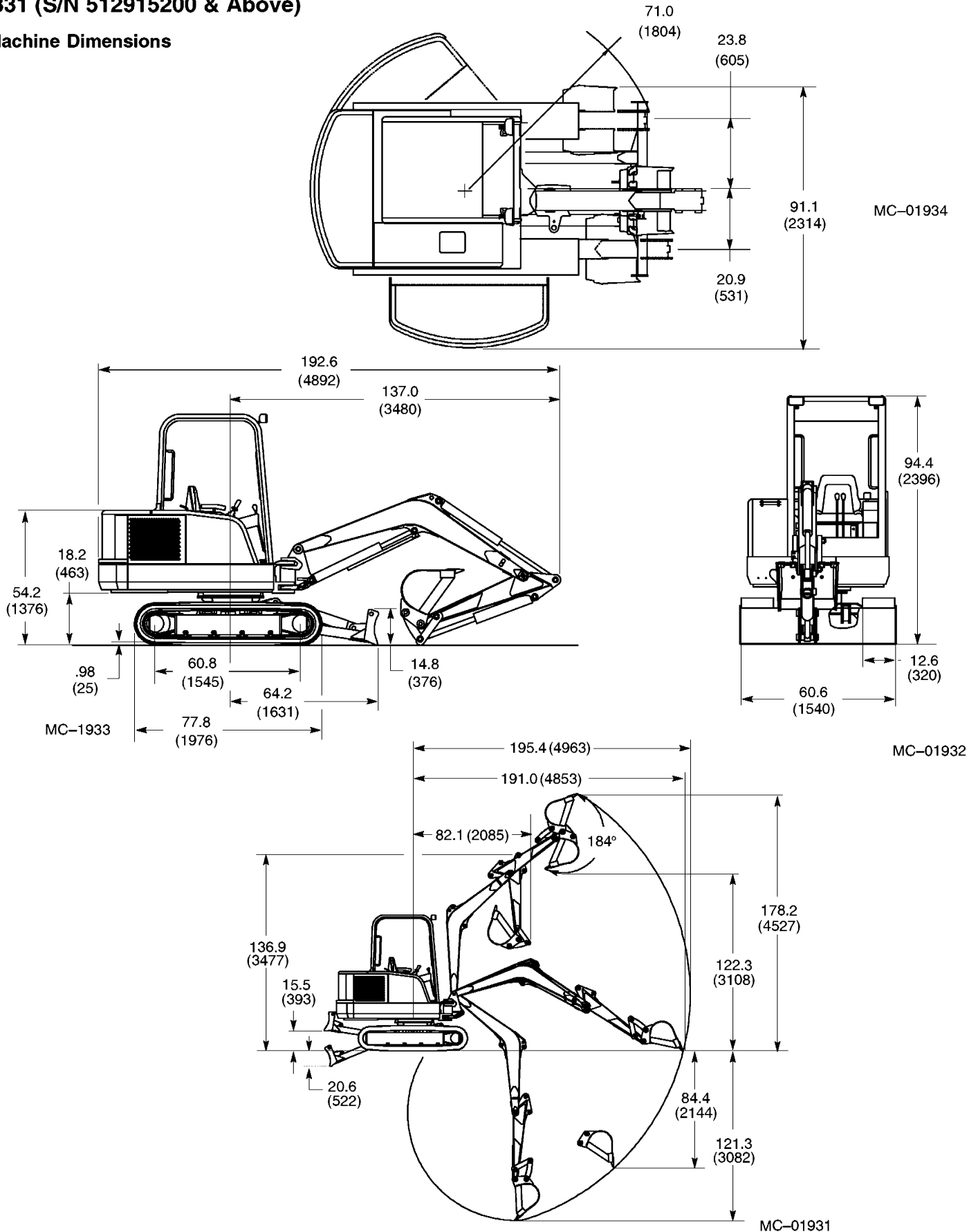

CLICK HERE TO **DOWNLOAD** THE COMPLETE MANUAL

- Thank you very much for reading the preview of the manual.
- You can download the complete manual from: www.heydownloads.com by clicking the link below



- Please note: If there is no response to CLICKING the link, please download this PDF first and then click on it.

CLICK HERE TO **DOWNLOAD** THE COMPLETE MANUAL