

# Operation & Maintenance Manual

# D41E, P-6

## BULLDOZER

SERIAL NUMBERS **D41E - B20001** and up  
**D41P - B20001**

This material is proprietary to Komatsu America International Company and is not to be reproduced, used, or disclosed except in accordance with written authorization from Komatsu America International Company.

It is our policy to improve our products whenever it is possible and practical to do so. We reserve the right to make changes or add improvements at any time without incurring any obligation to install such changes on products sold previously.

Due to this continuous program of research and development, periodic revisions may be made to this publication. It is recommended that customers contact their distributor for information on the latest revision.

CLICK HERE TO **DOWNLOAD** THE COMPLETE MANUAL

- Thank you very much for reading the preview of the manual.
- You can download the complete manual from: [www.heydownloads.com](http://www.heydownloads.com) by clicking the link below



- Please note: If there is no response to CLICKING the link, please download this PDF first and then click on it.

CLICK HERE TO **DOWNLOAD** THE COMPLETE MANUAL

## 6. GENERAL PRECAUTIONS

**⚠ WARNING:** For reasons of safety, always follow these safety precautions.

### SAFETY RULES

- ONLY trained and authorized personnel can operate and maintain the machine.
- Follow all safety rules, precautions and instructions when operating or performing maintenance on the machine.
- When working with another operator or a person on worksite traffic duty, be sure all personnel understand all hand signals that are to be used.

### SAFETY FEATURES

- Be sure all guards and covers are in their proper position. Have guards and covers repaired if damaged.  
**Proper position → See "12.1.1 WALK-AROUND CHECK".**
- Use safety features such as the safety lock and seat belts properly.
- NEVER remove any safety features. ALWAYS keep them in good operating condition.  
**Safety lever → See "12.10 PARKING MACHINE".**  
**Seat belts → See "12.1.4 USING SEAT BELT".**
- Improper use of safety features could result in serious bodily injury or death.

### CLOTHING AND PERSONAL PROTECTIVE ITEMS

- Avoid loose clothing, jewelry, and loose long hair. They can catch on controls or in moving parts and cause serious injury or death. Also, do not wear oily clothes because they are flammable.
- Wear a hard hat, safety glasses, safety shoes, mask or gloves when operating or maintaining the machine. Always wear safety goggles, hard hat and heavy gloves if your job involves scattering metal chips or minute materials - this is so particularly when driving pins with a hammer and when cleaning the air cleaner element with compressed air.  
Check also that there is no one near the machine.  
**Cleaning of air cleaner element → See "24.1 WHEN REQUIRED" in service procedure.**

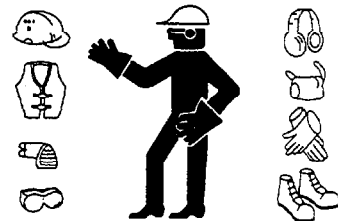

A0055010

**WORKING ON LOOSE GROUND**

- Avoid operating your machine too close to the edge of cliffs, overhangs, and deep ditches. If these areas collapse, your machine could fall or tip over and result in serious injury or death. Remember that the soil after heavy rain or blasting is weakened in these areas.
- Earth laid on the ground and the soil near ditches are loose. They can collapse under the weight or vibration of your machine.
- Install the HEAD GUARD or FOPS if working in areas where there is danger of falling rocks and dirt.
- When working in places where there is danger of falling rocks or danger of the machine turning over, install ROPS and a seat belt.

**PARKING THE MACHINE**

- Park on level ground whenever possible. If not possible, block the tracks, lower the blade to the ground and thrust the edge of the blade in the ground.

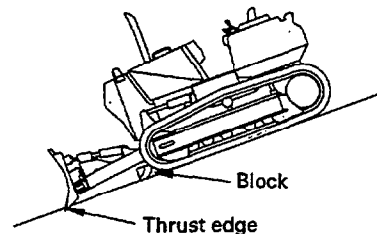

AE144050

- When parking on public roads, provide fences and signs, such as flags or lights, on the machine to warn passersby to be careful. Be sure that the machine, flags or lights do not obstruct traffic. **Parking procedure → See "12.10 PARKING MACHINE".**
- Before leaving the machine, lower the work equipment to the ground, move the SAFETY LEVER to LOCK position, stop the engine, and lock all the doors, windows, and covers and remove the key(s).  
**Work equipment posture → See "12.10 PARKING MACHINE".**  
**Locks → See "12.14 LOCKING".**

**PRECAUTIONS WHEN CARRYING OUT MAINTENANCE AT HIGH TEMPERATURE OR HIGH PRESSURE**

- Immediately after stopping operations, the engine cooling water and oil at all parts is at high temperature and under high pressure.

In this condition, if the cap is removed, or the oil or water are drained, or the filters are replaced, this may result in burns or other injury. Wait for the temperature to go down, then carry out the inspection and maintenance in accordance with the procedures given in this manual.

**Clean inside or cooling system → See "24.1 WHEN REQUIRED".**

**Check cooling water level, lubricating oil level → See "24.2 CHECK BEFORE STARTING".**

**Checking oil level in hydraulic tank, final drive case → See "24.4 PERIODIC MAINTENANCE".**

**Changing oil, replacing filters → See "24.5 - 7 PERIODIC MAINTENANCE".**



A0055050

**PRECAUTIONS WHEN USING HIGH PRESSURE GREASE TO ADJUST TRACK TENSION**

Grease is pumped into the track tension adjustment system under high pressure.

If the specified procedure for maintenance is not followed when making adjustments, the plug or grease fitting may fly out and cause damage or personal injury.

- When loosening the grease drain plug, never loosen it more than one turn.
- Never put your face, hands, feet, or any other part of your body directly in front of any grease drain plug or valve.

**Adjusting track tension → See "24.1 WHEN REQUIRED".**



A0055200

**ROTATING FAN AND BELT**

- Keep away from rotating parts and be careful not to let anything get caught in them.
- If your body or tools touch the fan blades or fan belt, they may be cut off or sent flying, so never touch any rotating parts.

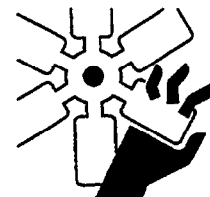

A0055210

**11.1 FRONT PANEL (METERS, LAMPS, SWITCHES)**

**11.1.1 MONITOR PANEL**

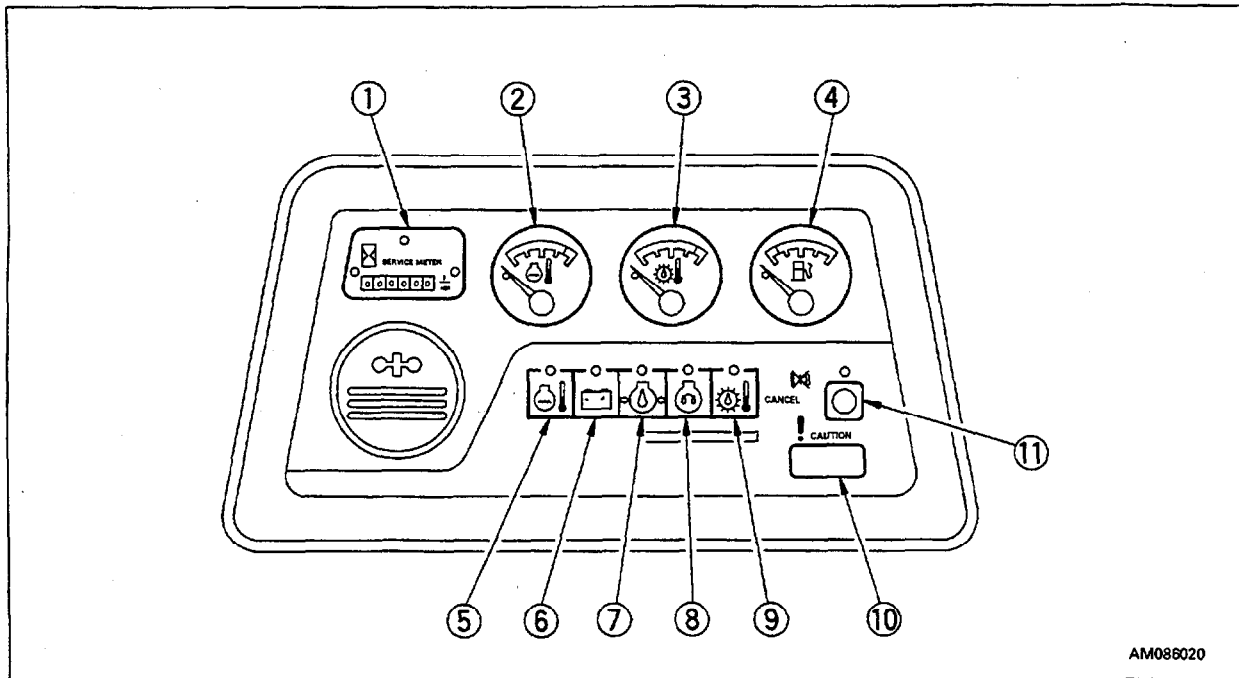

AM086020

**1. SERVICE METER**

This meter shows the total operation hours of the machine. The service meter advances while the engine is running – even if the machine is not traveling.

Set the periodic maintenance intervals using this display.

When the engine is running, the green pilot lamp ① at the top of the meters flashes to indicate that the meter is advancing.

Meter ② will advance by 1 for each hour of operation regardless of the engine speed.

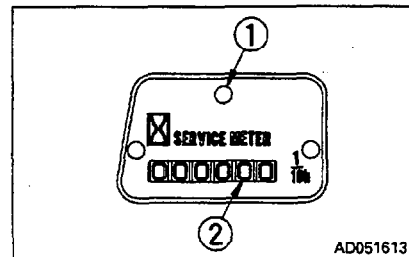

AD051613

**2. ENGINE WATER TEMPERATURE GAUGE**

This gauge indicates the cooling water temperature.

When the indicator is in the white range during operation, the water temperature is normal.

If the indicator moves from the white range into the red range during operation, stop the machine immediately, run the engine under no load at a midrange speed, and wait for the indicator to go down to the white range.

After starting the engine, warm up it until the indicator moves into the white range.

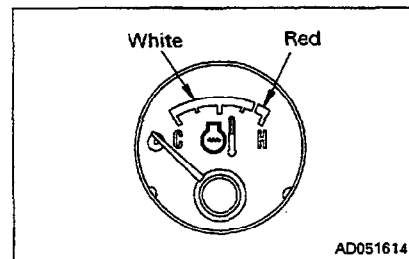

AD051614

## 11. EXPLANATION OF COMPONENTS

### 3. GLOW SWITCH (MONITOR PANEL SPECIFICATION)

This actuates the electrical heater to warm up the engine intake air.

**OFF position:** The preheating is not actuated.

**AUTO position:** AUTO preheating is actuated. The length of the preheating time varies according to the ambient temperature when the ambient temperature is below approx.  $-5^{\circ}\text{C}$ .

**I position:** This is used when AUTO preheating is not enough to start the engine in cold weather simply with the glow switch at the AUTO position.

When the switch is released, it will return to the AUTO position.

**II position:** This is used when carrying out preheating manually without using AUTO preheating.

When the switch is released, it will return to the OFF position.

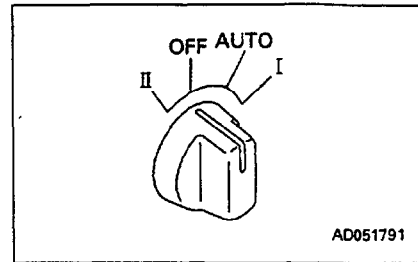

### 4. STARTING SWITCH

This switch is used to start or stop the engine.

**OFF (  ) position:**

The key can be inserted or withdrawn. The switches for the electric system are all turned off and the engine is stopped.

Do not the starting switch key at the OFF position while the engine is running.

**ON position:**

In this position, electric current flows in the charging and lamp circuits.

Keep the starting switch key at the ON position while the engine is running.

**START (  ) position:**

This is the position to start the engine. Hold the key at this position while cranking. Release the key immediately after the engine has been started. The key will return to ON position when released.

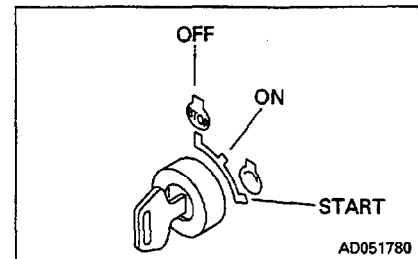

### 11.5 GREASE PUMP HOLDER

This is inside the left engine side cover.  
Fit the grease pump to the holder when it is not being used.

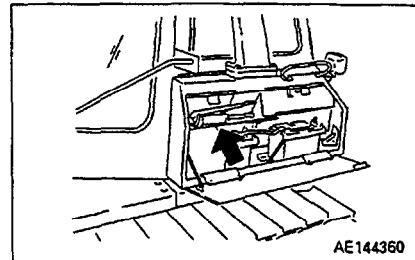

### 11.6 DOOR-OPEN LOCK (MACHINES EQUIPPED WITH CAB)

Use this when you want to keep the door held open.

1. Push the open door into door catch ①. The door will be held in position by the door catch.
2. To release the door, move lever ② inside the cab to the front of the cab. This will release the catch.

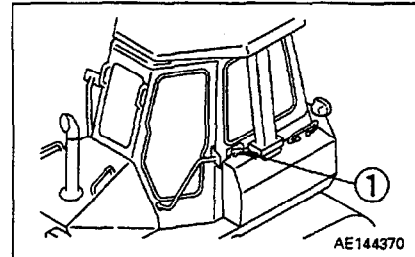

#### NOTICE

- When keeping the door open, fix it securely to the catch.
- Always close the door when traveling or carrying out operations. Leaving the door open will cause the door to break.
- Keep the door locked open securely.  
The door may swing closed because of the vibration.

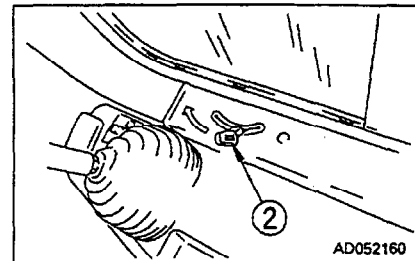

### 11.7 OPENING AND CLOSING REAR WINDOW (MACHINES EQUIPPED WITH CAB)

The rear glass can be opened or closed with a quarter lock.

If the left and right lock levers of the quarter lock are pulled up and pushed out at the same time, the glass moves to the open position.

If the left and right lock levers of the quarter lock are pulled up and pulled back in at the same time, the glass moves to the closed position.

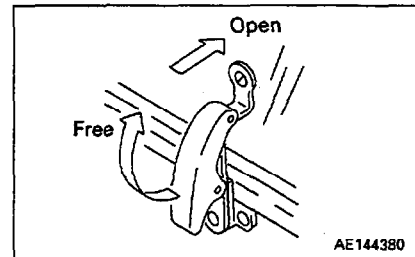

#### NOTICE

Keep the rear glass closed when traveling or during operations.  
Leaving it open will cause damage to the glass.

### 11.12.2 PRECAUTIONS WHEN USING

- If the head is dirty, clean it with a head cleaning tape.
- Never touch the head with a magnet, screwdriver, or any other hard object.
- Use a pencil to wind the tape to the outside to remove any slack.
- When not listening to the cassette tape, always remove it.
- Put the tape in its case. Do not keep the tape in any of the following places.
  - On top of the instrument panel
  - Any place where it is exposed to direct sunlight
  - Any place that is excessively humid
  - Any place that is excessively dusty
  - Any place where there is a strong magnetic field (near a speaker, etc.)
  - Any place where there is high temperature (near the car heater, etc.)
- Use a C-60 (60 minute) tape. Avoid using longer tapes as far as possible. In particular, do not use C-120 (120 minute) tapes. These tapes easily get caught up in the machine.
- When replacing the fuse, always use a 5A fuse.
- Do not put anything except a cassette tape in the tape insertion port.
- When cleaning, wipe off the dirt with a dry cloth. Never use any organic solvent such as thinner or benzene.

### 12.1.2 CHECK BEFORE STARTING

Always carry out the items in this section before starting the engine each day.

#### CHECK COOLANT LEVEL, ADD WATER

**⚠ WARNING**

Normally, do not open the radiator cap. When checking the cooling water level, check the sub-tank when the engine is cold.

1. Open the engine side cover on the left side of the chassis, and check that the cooling water is between the FULL and LOW marks on sub-tank ①. If the water level is low, add water to the FULL level through the water filler port in sub-tank ①.

**REMARK**

In summer, the coolant may overflow from the sub-tank drain hose. This is no problem. It occurs because too much coolant has been added.

2. After adding water, tighten the cap securely.
3. If the sub-tank is empty, check for leakage of water, then add water to the radiator and sub-tank.
4. After adding water, close the engine side cover.

#### CHECKING WITH MACHINE MONITOR

1. Turn starting switch ① to the ON position.
2. Check that all monitor lamps light up for 3 seconds, the warning lamp lights up for 2 seconds, and the alarm buzzer sounds for 1 second.

**REMARK**

- If the lamps do not light up, there may be a failure or disconnection in the monitor, so please contact your Komatsu distributor.
- When carrying out the checks before starting, do not rely only on the monitor. Always carry out all the items listed for periodic maintenance.

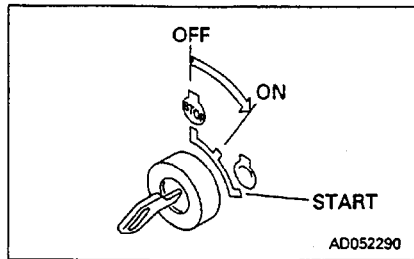
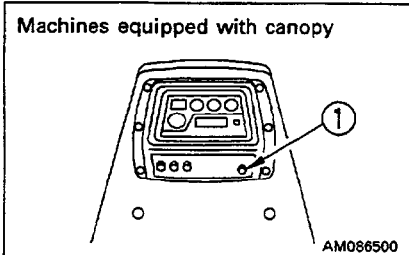
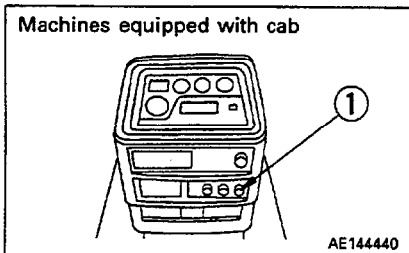
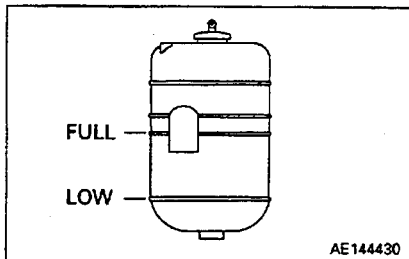
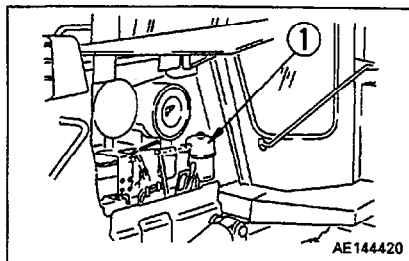

CLICK HERE TO **DOWNLOAD** THE COMPLETE MANUAL

- Thank you very much for reading the preview of the manual.
- You can download the complete manual from: [www.heydownloads.com](http://www.heydownloads.com) by clicking the link below



- Please note: If there is no response to CLICKING the link, please download this PDF first and then click on it.

CLICK HERE TO **DOWNLOAD** THE COMPLETE MANUAL

### 12.2.2 STARTING IN COLD WEATHER

When starting in low temperatures, do as follows.

**WARNING**

Never use starting aid fluids as they may cause explosions.

**NOTICE**

Do not keep the starting motor rotating continuously for more than 20 seconds.

If the engine fails to start, repeat steps 2 and 3 after waiting for about 2 minutes.

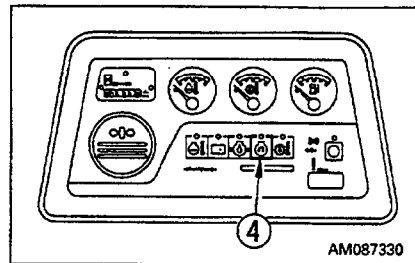
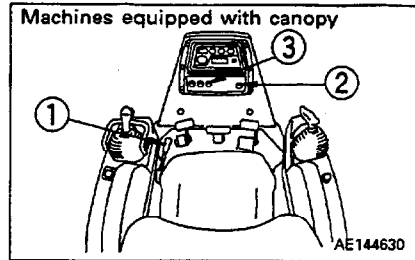
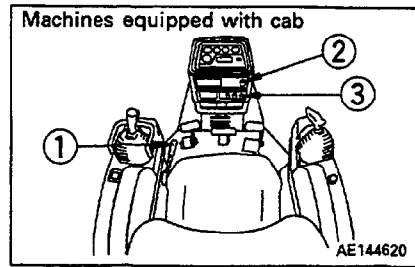

1. Pull fuel control lever ① to a position midway between the low idling and full speed positions.

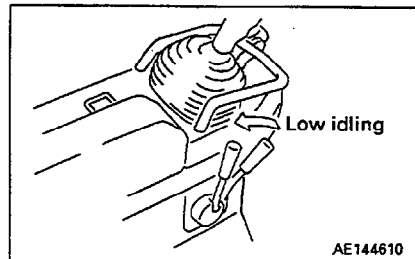

2. Insert the key into starting switch ② and turn the key to the ON position.

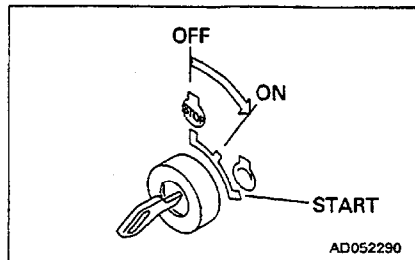

3. Carry out preheating.  
There are the following two ways of carrying out preheating.  
First use the convenient automatic preheating system.

## 12.8 STOPPING MACHINE

### WARNING

- Avoid stopping suddenly. Give yourself ample room when stopping.
- When stopping the machine, select flat hard ground and avoid dangerous places. If it is unavoidably necessary to park the machine on a slope, place the parking lever in the LOCK position and insert blocks underneath the track shoes. As an additional safety measure, thrust the blade into the ground.
- If the work equipment control lever is touched by accident, the work equipment may move suddenly, and this may lead to a serious accident. Before leaving the operator's seat, always operate the safety lever to place it securely at the LOCK position.

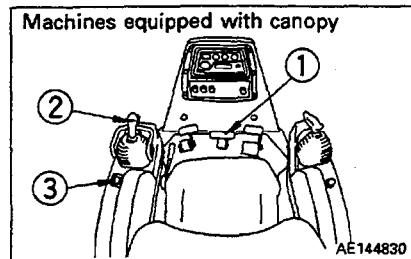
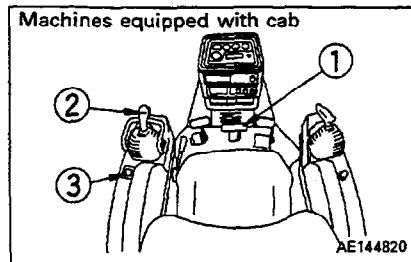

1. Depress brake pedal ① to stop the machine.

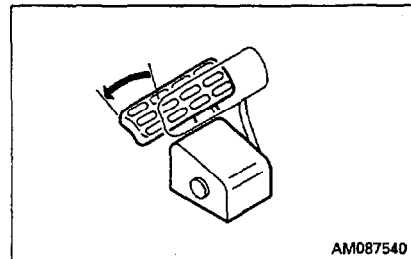

2. Place joystick ② in the N (neutral) position.

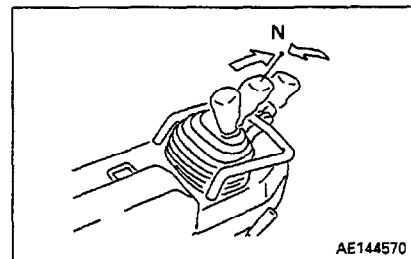

3. Operate joystick ② to 1st, and check that speed range display window ③ shows the correct position.

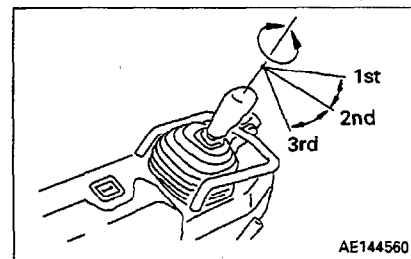

**12.16.2 INSPECTION AND ADJUSTMENT**

- Properly adjust track tension.  
Tension should be measured at clearance **A** shown in the diagram – usually 20 to 30 mm (0.8 to 1.2 in) at this point. For rocky terrain, tighten tracks slightly. In clay or sandy areas, slightly loosen them. (For inspection and adjustment procedures, refer to "24.1 WHEN REQUIRED").
- Check idler rollers for oil leakage as well as for loose bolts and nuts. If any trouble is detected, repair immediately.

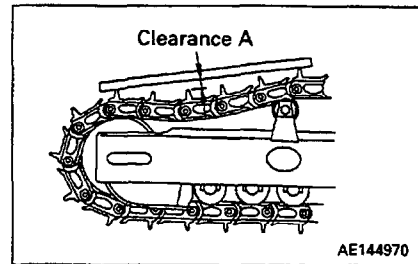

**12.16.3 INSPECTION AND REPAIR**

Frequent inspection and prompt repair will reduce repair costs.

The following items for inspection will serve as a guide to maintenance service of each undercarriage part. Perform periodical inspection and contact the Komatsu distributor in your area when machine has approached repairable limits and reversing limits.

**MEASURING LINK PITCH**

1. Insert a wooden block between track shoe and sprocket to take up the slack in track shoes.
2. Measure pitch length of 4 links in stretched portion at more than 2 links away from master pin. Of length obtained, 1/4 is the link pitch.

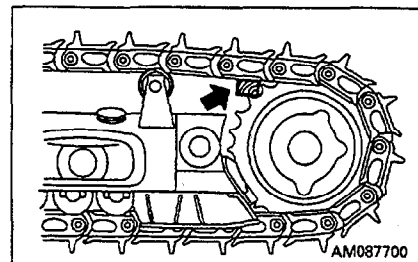

Basic link pitch (P): 171.5 mm (6.8 in)  
Link pitch limit for turning: 174.5 mm (6.9 in)

**REMARK**

There is no link window on the master link.

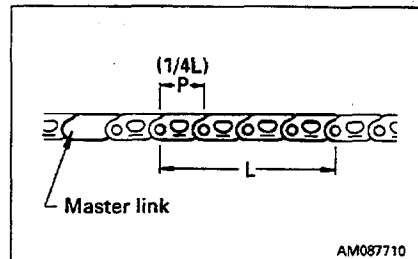

**MEASURING HEIGHT OF GROUSER (D41E)**

After taking up slack in track shoes, measure height at center of shoe as shown below.

Standard height (h): 53 mm (2.1 in)  
Repair limits: 25 mm (1 in)

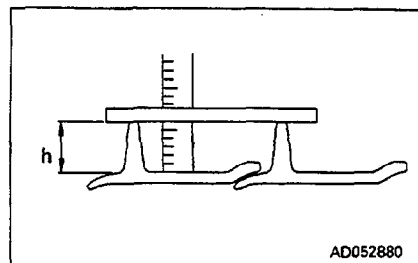

## 16. TROUBLESHOOTING

### 16.1 AFTER RUNNING OUT OF FUEL

When starting after running out of fuel, fill with fuel and bleed the air from the fuel system before starting.

For details of bleeding the air, see "24.5 EVERY 500 HOURS SERVICE"

### 16.2 IF BATTERY IS DISCHARGED

#### ⚠ WARNING

- When checking or handling the battery, stop the engine and turn the starting key to the OFF position before starting.
- The battery generates hydrogen gas, so there is danger of explosion. Do not bring lighted cigarettes near the battery, or do anything that will cause sparks.
- Battery electrolyte is dilute sulphuric acid, and it will attack your clothes and skin. If it gets on your clothes or on your skin, wash it immediately off with large amounts of water. If it gets in your eyes, wash it out with fresh water, and consult a doctor.
- When removing the battery, first disconnect the cable from the ground (normally, from the negative  $\ominus$  terminal). When installing, install the positive  $\oplus$  terminal first. If a tool touches the cable connecting the positive terminal and the chassis, there is danger that it will cause sparks.
- If the terminals are loose, there is danger that the defective contact may generate sparks that will cause an explosion. When installing the terminals, install them tightly.

#### 16.2.1 STARTING ENGINE WITH BOOSTER CABLE

When starting the engine with a booster cable, do as follows:

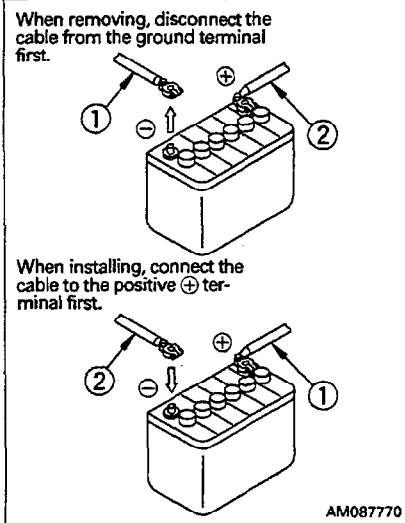

## 18. OUTLINES OF SERVICE

- Use Komatsu genuine parts for replacement.
- When changing or adding oil, do not use a different type of oil.
- Unless otherwise specified, the oil and coolant used at the time of shipment from the factory are as shown in the table below.

Item	Kind of fluid
Engine oil pan	SAE 15W-40 API classification
Damper case Transmission case Steering clutch case Final drive case	SAE 30 API classification
Hydraulic tank	SAE 10W API classification
Fuel tank	ASTM D975 No. 2 (However, ASTM D975 No. 1 is used for the winter season (October to March))
Radiator	Komatsu Super Coolant (AF-ACL) 41% added to water

### 18.1 OUTLINE OF OIL, FUEL, COOLANT

#### 18.1.1 OIL

- Oil is used in the engine and work equipment under extremely severe conditions (high temperature, high pressure), and it deteriorates with use.  
Always use oil that matches the grade and temperature for use given in the Operation and Maintenance Manual. Even if the oil is not dirty, always replace the oil after the specified interval.
- Oil corresponds to blood in the human body, so always be careful when handling it to prevent any impurities (water, metal particles, dirt, etc.) from getting in.  
The majority of problems with machine are caused by the entry of such impurities.  
Take particular care not to let any impurities get in when storing or adding oil.
- Never mix oils of different grades or brands.
- Always add the specified amount of oil.  
Having too much oil or too little oil are both causes of problems.
- If the oil in the work equipment is not clear, there is probably water or air getting into the circuit.  
In such cases, please contact your Komatsu distributor.
- When changing the oil, always replace the related filters at the same time.
- We recommend you to have an analysis made of the oil periodically to check the condition of the machine. For those who wish to use this service, please contact your Komatsu distributor.

## 22. PERIODIC REPLACEMENT OF SAFETY CRITICAL PARTS

To ensure safety at all times when operating or driving the machine, the user of the machine must always carry out periodic maintenance. In addition, to further improve safety, the user should also carry out periodic replacement of the parts given in the table. These parts are particularly closely connected to safety and fire prevention.

With these parts, the material changes as time passed, or they easily wear or deteriorate. However, it is difficult to judge the condition of the parts simply by periodic maintenance, so they should always be replaced after a fixed time has passed, regardless of their condition. This is necessary to ensure that they always maintain their function completely.

However, if these parts show any abnormality before the replacement interval has passed, they should be repaired or replaced immediately.

If the hose clamps show any deterioration, such as deformation or cracking, replace the clamps at the same as the hoses.

When replacing the hoses, always replace the O-rings, gaskets, and other such parts at the same time.

Ask your Komatsu distributor to replace the critical parts.

No.	Safety critical parts for periodic replacement	Q'ty	Replacement interval
1	Fuel hose (fuel tank – feed pump)	1	Every 2 years or 4000 hours, whichever comes sooner
2	Fuel hose (feed pump – fuel filter)	1	
3	Fuel hose (fuel filter – injection pump)	1	
4	Fuel hose (injection pump – fuel tank)	1	
5	Fuel hose (injection nozzle – fuel tank)	1	
6	Turbocharger lubrication hose	1	
7	Hose (power train strainer – power train pump)	1	
8	Hose (power train pump – power train filter)	1	
9	Hose (power train filter – priority valve)	1	
10	Hose (priority valve – transmission case)	1	
11	Hose (transmission case – oil cooler)	1	
12	Hose (oil cooler – transmission case)	1	
13	Hose (priority valve – PPC valve)	1	
14	Hose (PPC valve – brake valve)	2	
15	Hose (PPC valve – clutch piston)	2	
16	Hose (PPC valve – transmission case)	1	
17	Hose (priority valve – brake valve)	2	
18	Hose (brake valve – brake piston)	2	

**NOTICE**

If small holes or thinner parts are found on the element when it is checked with an electric bulb after cleaning and drying, replace the element.

Do not use an element whose folds or gasket or seal are damaged.

When cleaning the element, do not hit it or beat it against something.

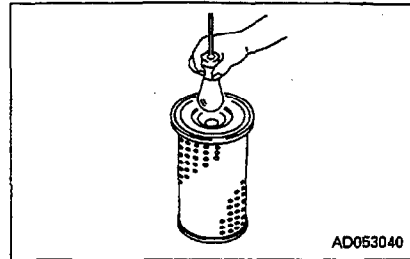

4. Set the cleaned element and cover ③.

**Replacing inner element**

1. First remove the cover and the outer element, and then remove the inner element.
2. To prevent dust from getting in, use a clean cloth or tape to cover the air connector (outlet side).
3. Clean the air cleaner body interior, then remove the cover installed in Step 2.
4. Fit a new inner element to the connector and tighten it with nuts. Do not clean and reinstall a inner element.
5. Install the outer element and the cover.
6. After replacing the element, return the red piston in the dust indicator to its original position.

### 24.2.3 CHECK FUEL LEVEL, ADD FUEL

**⚠ WARNING**

**When adding fuel, never let the fuel overflow. This may cause a fire. If you spill fuel, thoroughly clean up any spillage.**

1. Turn the engine starting switch to the ON position and check the fuel level with fuel level gauge **Ⓒ** on the monitor panel. After checking, turn the switch back to the OFF position.
2. After completing work, fill the fuel tank through oil filler port **Ⓕ**. For details of the method of opening and closing the cap, see "11.8 CAP WITH LOCK". For details of the fuel to use, see "20. USE OF FUEL, COOLANT AND LUBRICANTS ACCORDING TO AMBIENT TEMPERATURE".
3. After adding fuel, tighten the cap securely.  
Fuel capacity: 225 ℓ (59.4 US gal, 49.5 UK gal)

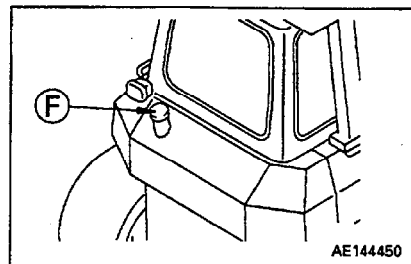
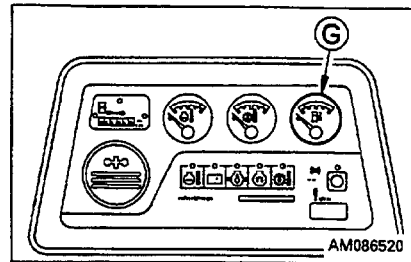

### 24.2.4 CHECK OIL LEVEL IN ENGINE OIL PAN, ADD OIL

1. Open the engine side cover on the left side of the chassis.
2. Remove dipstick **Ⓒ** and wipe the oil off with a cloth.
3. Insert dipstick **Ⓒ** fully in the oil filler pipe, then take it out again.
4. The oil level should be between the H and L marks on dipstick **Ⓒ**.  
If the oil is below the L mark, open the inspection cover on top of the engine hood and add engine oil through oil filler **Ⓕ**. For details of the oil to use, see "20. USE OF FUEL, COOLANT AND LUBRICANTS ACCORDING TO AMBIENT TEMPERATURE".
5. If the oil is above the H mark, drain the excess engine oil from drain plug **Ⓖ**, and check the oil level again.
6. If the oil level is correct, tighten the oil filler cap securely and close the engine side cover.

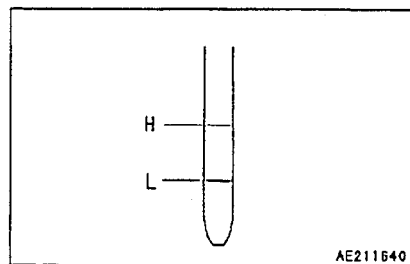
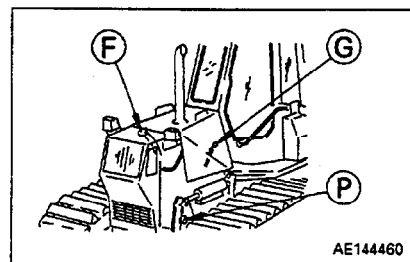

**REMARK**

When checking the oil level after the engine has been operated, wait for at least 15 minutes after stopping the engine before checking.

If the machine is at an angle, make it horizontal before checking. The oil level between the L and H marks is 7.5 ℓ (2.0 US gal, 1.7 UK gal).

### 24.4.7 CHECK BRAKE PERFORMANCE

**WARNING**

If the machine moves during the following operation, please contact your Komatsu distributor for repairs immediately.

**NOTICE**

Do not place the gear shift lever in 1st under any circumstances. The machine will be damaged.

Before starting the engine, check that the area around the machine is safe, then do as follows.

1. Depress inching pedal ⑦ fully.
2. Start the engine.
3. Set safety lever ① to the FREE position then operate blade control lever ② to raise the blade.  
Leave the safety lever to the FREE position.
4. Set parking lever ③ to the FREE position.
5. Operate fuel control lever ⑥ and pull to a position midway between the low idling and high idling positions.
6. Depress brake pedal ④, set joystick ⑤ to 2nd, check that the display on speed range display window ⑧ shows 2nd, then move joystick ⑤ to the FORWARD position.
7. Keep brake pedal ④ depressed and slowly release inching pedal ⑦.
8. If the machine does not move with the above operation when the engine is stopped, the service brake is normal.
9. Next, check the parking brake.  
Move the machine to a slope and stop it with the front facing downhill.
10. With the engine running, depress the brake pedal and return the directional lever to neutral to stop the machine on the slope.
11. Push the parking brake lever down to the lock position. Then release the brake pedal and check that the machine does not move. If the machine does not move, the parking brake is normal.

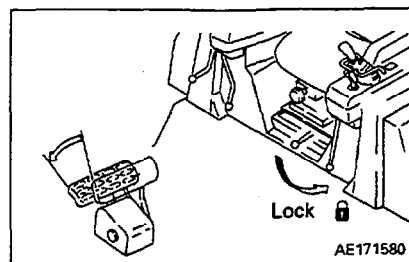
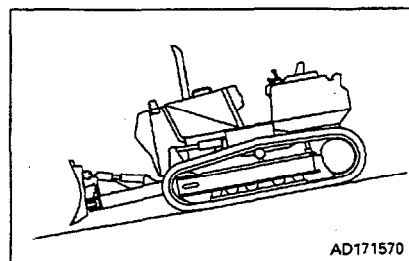
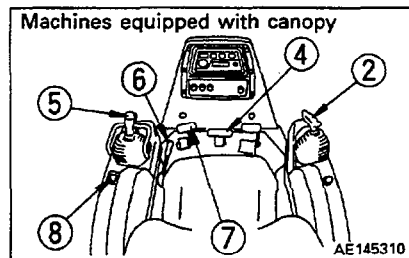
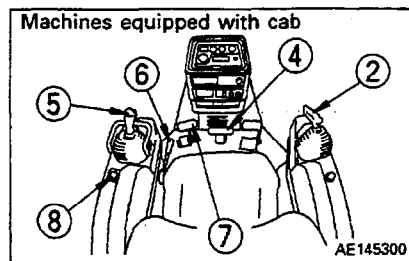
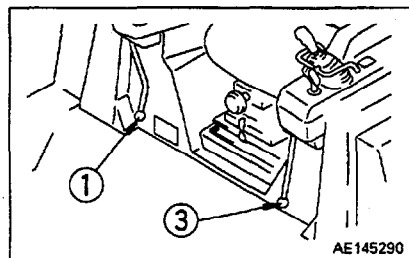

### 24.7.2 CHANGE OIL IN FINAL DRIVE CASE

**⚠ WARNING**

The oil is at high temperature immediately after the machine has been operated. Wait for the oil to cool down before starting the operation.

Prepare the following.

- Container to catch drained oil: Min. 13 ℓ capacity
- Refill capacity: 13 ℓ (3.4 US gal, 2.9 UK gal)

1. Stop the machine so that drain plug ① is directly at the bottom.
2. Remove oil level plug ②, then remove drain plug ③, and drain the oil. After draining the oil, tighten the plugs.
3. Add engine oil through the hole in oil level plug ② to the specified level (oil overflows from the plug hole).  
For details of the oil to use, see "20. USE OF FUEL, COOLANT AND LUBRICANTS ACCORDING TO AMBIENT TEMPERATURE".
4. Check that the oil is at the specified level.  
For details, see "24.4 EVERY 250 HOURS SERVICE".
5. Install oil level plug ②.

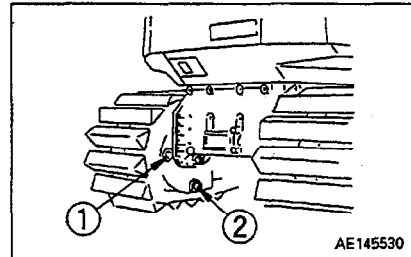

### 24.7.3 CHECK ALTERNATOR, STARTING MOTOR

The brush may be worn, or the bearing may have run out of grease, so contact your Komatsu distributor for inspection or repair.

If the engine is started frequently, carry out inspection every 1000 hours.

### 24.7.4 CHECK VIBRATION DAMPER

Check for any cracks or peeling on the outside surface of the rubber.

If there are any cracks or peeling, please contact your Komatsu distributor to have the parts replaced.

### 24.7.5 CHECK ENGINE VALVE CLEARANCE, ADJUST

Contact your Komatsu distributor for inspection or adjustment.

CLICK HERE TO **DOWNLOAD** THE COMPLETE MANUAL

- Thank you very much for reading the preview of the manual.
- You can download the complete manual from: [www.heydownloads.com](http://www.heydownloads.com) by clicking the link below



- Please note: If there is no response to CLICKING the link, please download this PDF first and then click on it.

CLICK HERE TO **DOWNLOAD** THE COMPLETE MANUAL