

Operation & Maintenance Manual



PC128UU-1

HYDRAULIC EXCAVATOR

SERIAL NUMBERS **PC128UU-1 -1001** and up

This material is proprietary to Komatsu Utility Corporation and is not to be reproduced, used, or disclosed except in accordance with written authorization from Komatsu Utility Corporation.

It is our policy to improve our products whenever it is possible and practical to do so. We reserve the right to make changes or add improvements at any time without incurring any obligation to install such changes on products sold previously.

Due to this continuous program of research and development, periodic revisions may be made to this publication. It is recommended that customers contact their distributor for information on the latest revision.

CLICK HERE TO **DOWNLOAD** THE COMPLETE MANUAL

- Thank you very much for reading the preview of the manual.
- You can download the complete manual from: www.heydownloads.com by clicking the link below



- Please note: If there is no response to CLICKING the link, please download this PDF first and then click on it.

CLICK HERE TO **DOWNLOAD** THE COMPLETE MANUAL

7. BASIC PRECAUTIONS

⚠ Warning! Follow these precautions to ensure safety

Keep flames away from fuel and oil

Flames may ignite fuel, oil and anti-freeze if they are in close proximity. Fuel is particularly flammable and hazardous.

- Do not smoke or light matches near flammable materials.
- Refuel after stopping the engine and extinguishing cigarettes.
- Tighten all fuel and oil caps securely.
- Store fuel and oil in well-ventilated areas.
- Fuel and oil should be kept in designated places and unauthorized persons should not be allowed entry.



Precautions when handling at high temperatures

- Immediately after operation, engine coolant, engine oil and transmission oil are hot and build up pressure. Serious burns may be caused if caps are removed, oil or coolant is drained or filters are changed in this condition. Wait until the temperature has gone down and perform these operations following the prescribed procedures.
- To prevent hot coolant from boiling over
 - 1) Stop the engine
 - 2) Wait until the temperature of the coolant has gone down.
 - 3) Remove the cap after slowly rotating it and releasing the pressure.
- To prevent hot oil from escaping.
 - 1) Stop the engine
 - 2) Wait until the temperature of the oil has gone down.
 - 3) Remove the cap after slowly rotating it and releasing the pressure.



8.3 TRANSPORT THE VEHICLE

Precautions when loading and unloading the vehicle

- Loading and unloading the machine for transport is especially hazardous. Be especially cautious.
- When loading and unloading, the engine should be idling slowly and should be run in low gear.
- Select a firm, level place for loading and make sure that it is a sufficient distance from the shoulder of the road.
- Use ramps that are of adequate strength and make sure that they are sufficiently wide, long and thick for safe loading and unloading. If the ramps are likely to bend significantly, reinforce them with blocks.
- Remove oil residues and foreign matter that may be stuck to the ramps so that the machine will not slide. Remove mud from around the tracks.
- Never correct the position of the tracks on the ramp while on the ramp. If you need to correct the position of the tracks, back off of the ramp, correct the position of the tracks and the remount the ramp.
- If you are going to swing the arm and boom apparatus on the trailer, do so with caution as the machine's footing is unstable.
- After the machine has been loaded, secure the vehicle with wedges and wire rope.
How to load and unload → See item 14. Transporting
How to secure → See item 14. Transporting

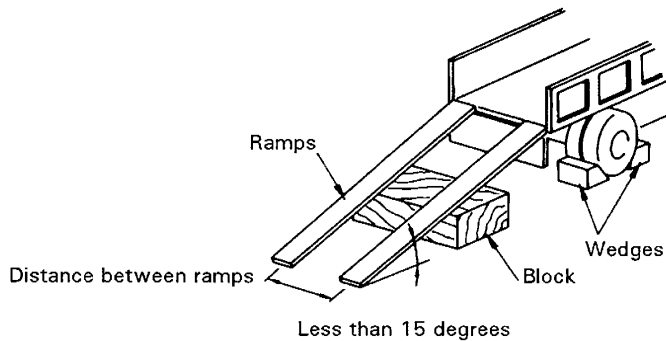

Precautions when transporting

- Transport the vehicle safely in accordance with all pertinent regulations.
- Consider the maximum width, height and weight of the machine when it is loaded on the trailer when deciding on a route to transport the vehicle.

9. PRECAUTIONS FOR MAINTENANCE

Precautions with battery

Remove the connection to the negative terminal to stop the flow of electrical current if you are going to repair the electrical system or do electric welding.



Handling high pressure hoses

- Do not bend or clamp hard objects on high pressure hoses. Do not use piping, tubes or hoses with bends or cracks as they may rupture.
- Always repair fuel hoses and hydraulic hoses that have breaks or have soft spots.

Be careful of hydraulic fluid under high pressure

- Always remember that hydraulic lines for the boom and arm are under pressure.
- Do not add fluid, drain fluid, check or engage in repair operations until the pressure gauge reads zero.
- Leaks of hydraulic fluid under pressure from small holes can be dangerous if it gets on the skin or in the eyes. Wear safety glasses and thick gloves, and use a piece of card board or a sheet of plywood to test the leak that you wish to check.
- If you are hit by a jet of hydraulic fluid under pressure see a doctor immediately.



12. EXPLANATION OF EACH DEVICE

Each device necessary for operation is explained.

The most important thing for proper, safe and smooth operation is to properly understand the ways to operate these devices and to understand what the gauges mean.

12.1 VEHICLE MONITOR PANEL

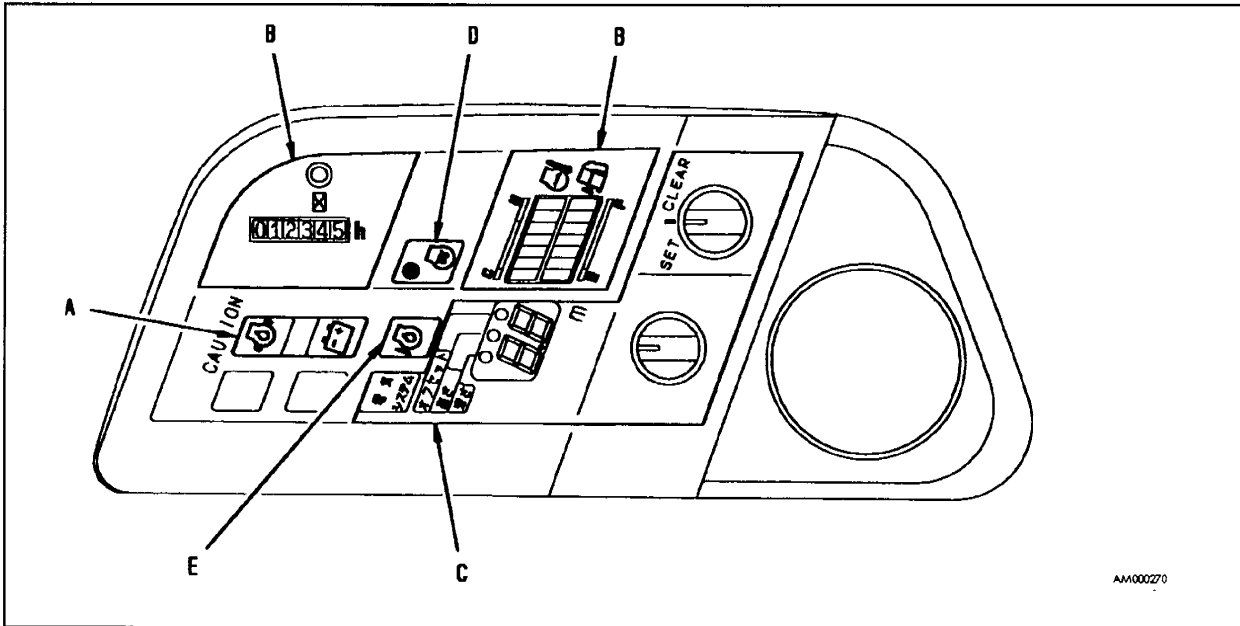

The monitor panel shows the basic items that must be checked before starting the engine.

Lights will come on for anything that is abnormal on the monitor panel.

The light will go out when the engine is started even if there is something abnormal.

A. Emergency stop items (12.1.1)

When the engine is running and there is something abnormal the item that needs to be taken care of will be indicated.

The monitor light will flash and a buzzer will sound when something is abnormal.

⚠ Caution!

Immediately cease operations and check and repair the problem when these monitors flash.

12. EXPLANATION OF EACH DEVICE

8. Knob switch (optional)

The knob switch on the left control lever for the boom and arm apparatus is used for instantly increasing power for excavating operations.

Push once and continue to push (single click). The increased excavating power lasts for a maximum of 8.5 seconds.

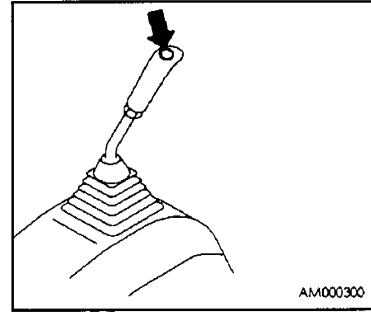

9. Auto diesel release switch (optional)

This is a switch that functions to automatically reduce engine RPM and reduce fuel consumption when the control lever is in neutral and at other times when engine output is not needed.

ON position: Auto diesel is on.

OFF position: Auto diesel is off.

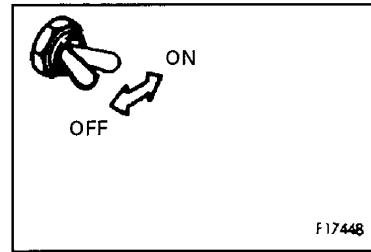

You may select on or off by alternating the switch position.

⚠ Warning!

Be cautious when operating the control lever in the diesel range as engine RPM will suddenly increase.

Engine RPM for the forward and reverse travel control levers, the right and left arm and boom apparatus control levers and the blade lever will change as follows by the use of the auto diesel feature.

- When each of these levers is in the neutral position and the fuel adjustment control lever is set higher than medium speed, engine RPM will decrease to medium speed. If any of the levers is moved, engine RPM will increase to the level set by the fuel adjustment control lever.

12.9 LOCKING CAP AND COVERS

The fuel tank cap, the cab, the engine hood, the left side cover and right side cover are all outfitted with locks.

Use the ignition switch key to remove and replace the fuel tank cap.

12.9.1 How to remove and replace the locking cap for refueling the fuel tank

■ **To remove**

1. Insert the key
2. Turn the key in a counterclockwise direction and align the opening of the rotor groove with the mark on the cap and you may remove the cap.

■ **To lock**

1. Screw in the cap.
2. Turn and remove the key.

Turn the key only after fully inserting it. If you turn it when not fully inserted, you may bend and damage the key.

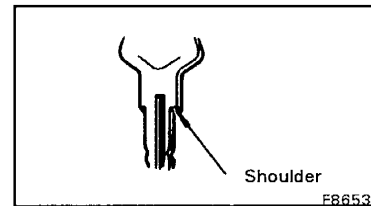
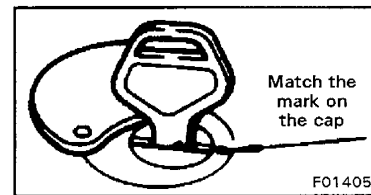
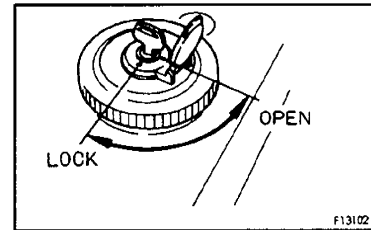

12.9.2 How to open and close covers with locks

■ **To open (when they are locked)**

1. Insert the key.
2. Turn the key in a counterclockwise direction, and if you can grasp the cover handle you can open it.

■ **To lock**

1. Close the cover and insert the key.
2. Turn the key in a clockwise direction and remove it.

13. OPERATION

13.1.2 Checks before beginning operations

Perform these checks once daily prior to starting the engine the first time.

■ Check the coolant level and add if necessary



Warning!

Do not remove the radiator cap. When the engine is cold, coolant level may be checked with the reserve tank.

1. Open the engine hood and check to see whether the coolant level in the reserve tank (1) is between FULL and LOW. If the level is low add coolant to reserve tank (1) until it is at the full level.
2. Tighten the cap securely when you have finished adding coolant.
3. If the reserve tank is empty check for leaks. Then check the coolant level in the radiator. If low add coolant to the radiator and then to the reserve tank.

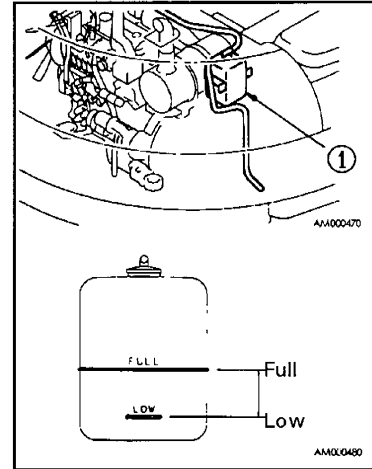

■ Check the oil in the engine oil pan and add if needed.

1. Open the engine hood
2. Remove dipstick (G) and wipe it off with a rag.
3. Reinsert dipstick (G) as far as it will go and then remove.
4. If there is oil on the dipstick (G) between H and L, the level is satisfactory. If the level is below L add oil at (F).

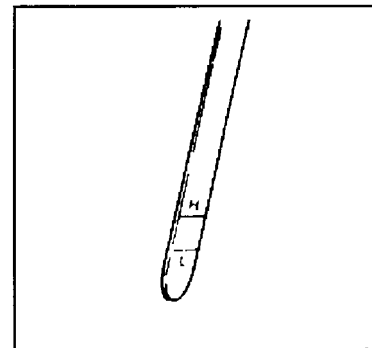
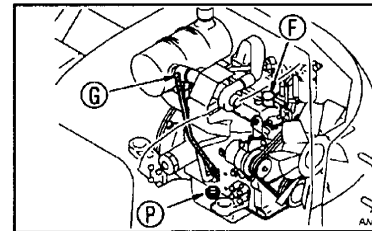

For the oil to use see item 21, "Use of fuel and lubricants by ambient temperatures".

13. OPERATION

2. Set the locking lever (2) to the free position and raise the bucket from the ground.

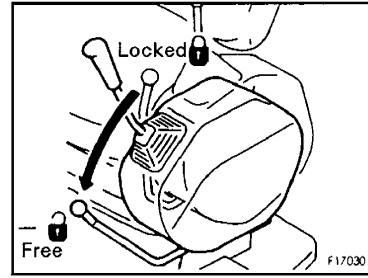

3. Move the right arm and boom apparatus control lever (3) slowly and move the bucket cylinder to the end of the stroke and maintain it there for 5 minutes.

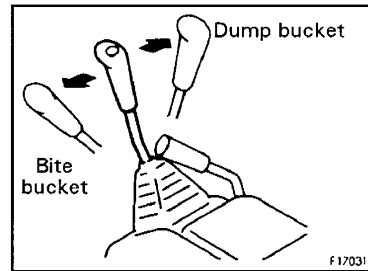

4. After warming up the machine, make sure that each of the monitor lamps and gauges are as follows:

- Engine coolant temperature gauge (4) In the green range
- Fuel gauge (5) In the green range
- Engine oil pressure monitor (6) Light is out
- Charge level monitor (7) Light is out
- Engine oil level monitor (8) Light is out (optional)
- Electrical system monitor (9) Light is out

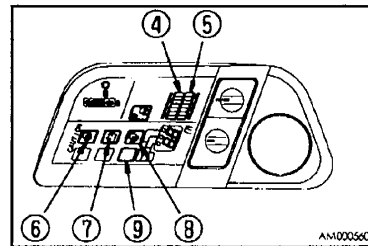

5. Make sure there is no abnormal color to the exhaust gas, unusual sounds or vibrations. If something is abnormal repair it.

6. Place the locking lever (2) in the locked position and make sure that the arm and boom apparatus cannot be operated with the left and right control levers and that it cannot be swung.

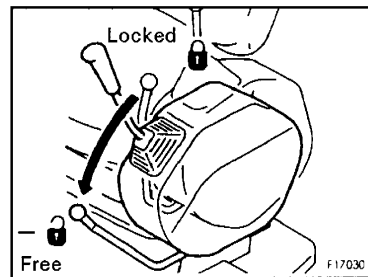

7. Place the locking lever (2) in the free position and check the accident prevention device as follows.

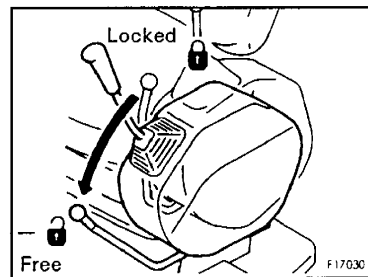

13. OPERATION

- **Be careful that the arm cylinder does not hit any obstacles**

When the arm is moved, the rear position of the arm cylinder varies. Be careful so that it does not get hung up on power lines or contact anything unintended.

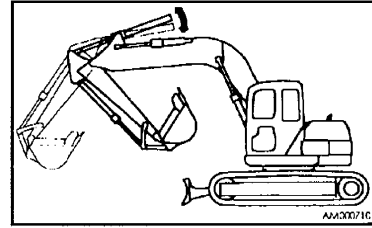

- **Do not move the travel speed control lever suddenly when accelerating speed.**

- (1) Do not move the lever suddenly so that the machine lurches forward.
- (2) Do not move the lever suddenly when going from forward to reverse (or from reverse to forward)
- (3) Do not move the lever suddenly (by releasing the lever suddenly) so that a sudden stop occurs when the vehicle is traveling at maximum speed.

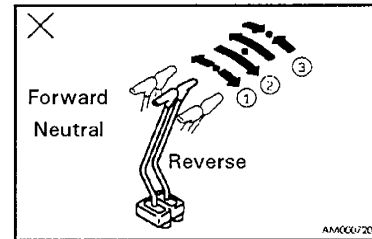

13. OPERATION

13.17 CHECKS AFTER THE ENGINE HAS BEEN STOPPED

1. Make a visual check for oil and water leaks, visually check the arm and boom apparatus, around the undercarriage and exterior equipment. If there are leaks or any problems have them repaired.
2. Top off the fuel tank
3. Remove any paper or debris from the engine compartment as they may cause a fire.
4. Remove any mud etc. that may have become stuck to the undercarriage.

13.18 LOCKING

Always lock the following items on the machine.

- (1) The door of the cab
Always close the window.
- (2) The fuel tank cap.
- (3) The engine hood.
- (4) The left side cover (battery compartment)
- (5) The right side cover (the pump compartment)

Additional explanation

The ignition key is used for all of these locks.

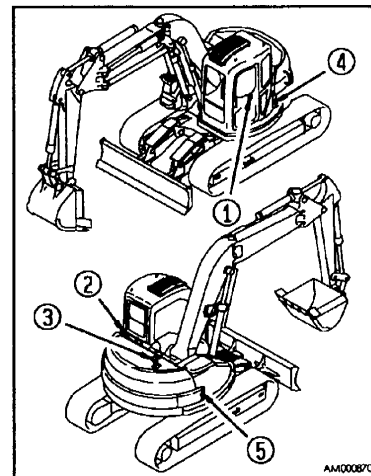

13. OPERATION

■ Setting height mode

If you raise the boom to the height arbitrarily set, the apparatus will automaticall stop.

1. Place the mode selection switch (1) in the height mode position.
2. Raise the boom to the designated position.
3. Place set switch (2) in the SET position. A buzzer will sound twice and the light of indicator (3) will come on.
4. If you lower the boom and then raise it, it will stop at the designated height.

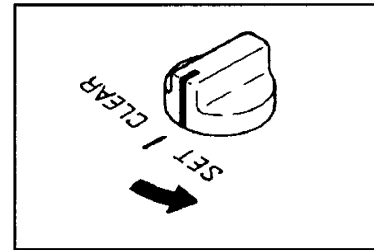
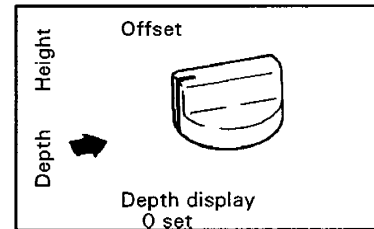
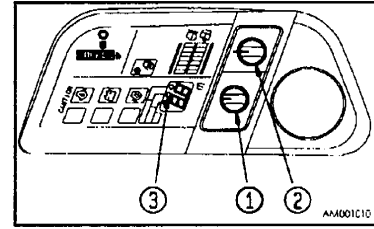

NOTICE

In height mode the height the boom will rise to is set. If the height is set when the arm and bucket are retracted as shown in the diagram to the right, the height of the apparatus may be greater when the arm and bucket are extended forward. Be careful not to make undesired contact with objects surrounding the machine.

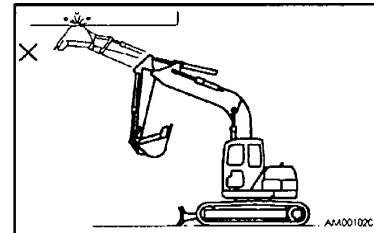

5. To clear the height mode, place the mode selection switch (1) to the depth mode position and the setting switch (2) to CLEAR. The light on indicator (3) will go out.

Additional explanation

Even though you may have set a mode, if you turn the ignition switch to the OFF position the mode setting will be cleared.

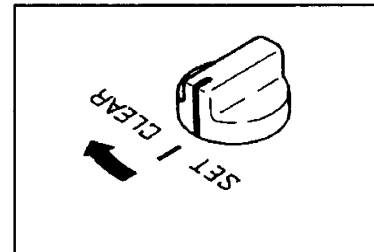

CLICK HERE TO **DOWNLOAD** THE COMPLETE MANUAL

- Thank you very much for reading the preview of the manual.
- You can download the complete manual from: www.heydownloads.com by clicking the link below



- Please note: If there is no response to CLICKING the link, please download this PDF first and then click on it.

CLICK HERE TO **DOWNLOAD** THE COMPLETE MANUAL

14. TRANSPORTING

14.3 PRECAUTIONS WHEN TRANSPORTING

Warning!

- Take into consideration the width of the road, the height of obstacles on it and the weight that it can bear when selecting a route for transporting the vehicle.
- Always make sure that the door to the cab as well as both the right and left side covers are locked before transporting the vehicle.

NOTICE

Always retract the antenna of the car radio.

When transporting the vehicle consult Komatsu or your Komatsu distributor as there are the following regulations set by law.

Regulations

Total weight: Less than 20 tons
See the diagram at right for height and width

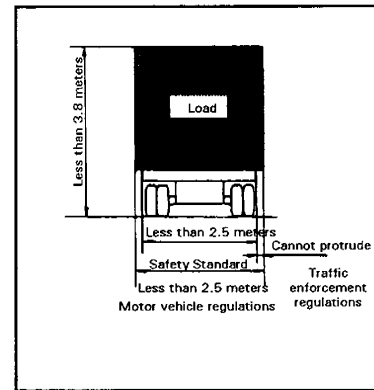

17.5.1 Starting the engine using booster cables

Observe the following procedure when starting the engine using booster cables

■ Precautions in connecting and removing booster cables

Warning!

- Never connect the positive terminal to the negative terminal when attaching cables
- Wear safety glasses when using booster cables to start the engine.
- When using another vehicle to start the engine make sure that the other vehicle does not touch your vehicle. Because batteries emit hydrogen gas there is the danger that an explosion might occur if sparks are generated near the battery.
- Do not make mistakes in connecting the booster cables. Never, ever connect a positive terminal with a negative terminal.
- The final connection should be to the frame of the rotating arm and boom. Make sure that this is as far from the battery as possible as this will cause a spark. (However, do not connect the cable to the arm and boom apparatus as conductivity is poor)
- When disconnecting booster cables, do not allow the respective clips of the two cables to contact each other or to contact the body of the machine.

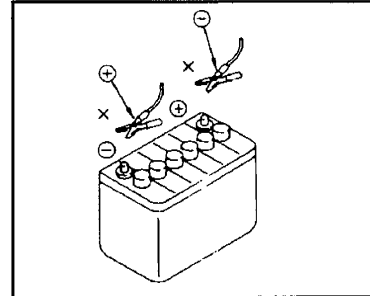

NOTICE

- Use cables and clips of a size suitable for the battery.
- The battery of the assisting vehicle should be of the same capacity as that of the vehicle to be started.
- Check to see whether there is any damage or corrosion on the cable and clips.
- Fasten the clips securely so there is a good connection.

18. PRECAUTIONS IN PERFORMING CHECKS AND MAINTENANCE

Do not perform any checks or maintenance operations other than those specified in this manual.

Park the machine on firm, level ground before performing inspections and maintenance operations.

Check the service meter:

Check the service meter every day to see if the time has come for any necessary maintenance to be performed.

Genuine Komatsu parts (for replacement parts):

Use genuine Komatsu replacement parts specified in the Parts List for replacement parts.

Genuine Komatsu Oils (for lubrication):

Use genuine Komatsu oils for lubrication. Use products with the proper viscosity specified according to ambient temperature.

Use clean washer fluid:

Use washer fluid for use in automobiles and ensure that dirt and foreign matter do not get in it.

Use clean oil and grease:

Use clean oil and grease, and keep containers and grease guns clean so that dirt and foreign materials cannot get mixed with oil and grease.

Keep the machine clean:

Wash the machine and keep it clean so that problems with components can be easily diagnosed. In particular, keep grease fittings, breathers and oil level gauges clean. Keep dirt from getting mixed into the oil and grease.

Be careful of hot water and oil:

Draining oil and water and changing filters immediately after stopping the machine while it is still hot is dangerous. Wait until the temperature of the engine has cooled down before doing these tasks. Conversely, if the oil has to be drained when it is cold, warm up the engine some and then drain it. (approximately 20 to 40°C.

Check the drained oil and filters:

After changing oil and filters, check the oil that was drained and the filter that was replaced to make sure that there were no large quantities of metal particles or other foreign matter.

Precautions when adding oil:

If your machine is equipped with a strainer over the filler port, do not remove this strainer while filling the machine with oil

Be careful so that dirt does not get in:

Check the oil and replace the filters in places where there is not likely to be much dust and prevent dirt and other foreign matter from getting in.

21. USAGE OF FUEL AND LUBRICATING GREASE ACCORDING TO AMBIENT TEMPERATURE

21.1 FUEL/ OIL

Use them in accordance with the table below.

The prescribed amount of oil is the total amount of oil including the amount in oil lines of each device etc. The change amount is the amount of oil to be changed during checks and maintenance.

When starting the engine at temperatures below 0°C always use SAE10W, SAE10W-30 or SAE15W-40 even when the temperature will rise to 10°C during the day.

21.2 COOLANT

Genuine Komatsu Supercoolant (AF-ACL) has been added to the coolant fluid so that there is no need to change it if the temperature does not go below -10°C.

When the temperature goes below -10°C, see item 25.2 of the manual " Maintenance that is not regularly scheduled" and adjust the concentration accordingly.

Reservoir	Type of fluid	Temperature °C								(ℓ) Refill	(ℓ) Change amount
		-30	-20	-10	0	10	20	30	40		
Engine oil pan	Engine oil				SAE30CD				12	11	
			SAE10W CD								
			SAE10W-30CD								
			SAE15W-40CD								
Swing machinery case	Engine oil								2.5	2.5	
Final drive case			SAE30CD							Left, right each 2.5	Left, right each 2.5
PTO gear case										0.75	0.75
Hydraulic oil system	Engine oil		SAE10W CD							140	92
			SAE10W-30CD								
			SAE15W-40CD								
	Hydraulic oil		HO46-HM*								
Fuel tank	Light oil		JIS number 2							135	-
			JIS number 3								
			JIS number 3								
Cooling system	Water	Add Genuine Komatsu Supercoolant (AS-ACL)								15.7	-

*Note: For HO46-HM use oils recommended by Komatsu. For the change amount see item 19.1.1 "Oil".

25. SERVICE PROCEDURES

5. Replace the element if you find small holes on the inside of the element after cleaning it and then checking it by illuminating the inside of the element with a light bulb.

NOTICE

Do not strike the element with anything or beat it against anything when cleaning it.

Do not use an element whose folds, gaskets or seals are damaged. Store unused elements wrapped or packaged and keep them in a dry place.

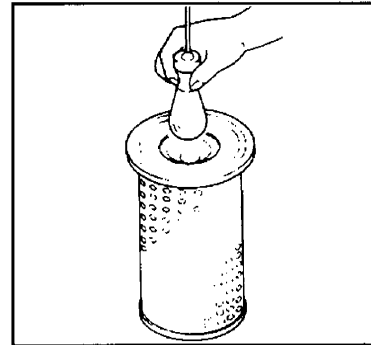

6. Remove the cloth or tape that you placed on the air connector opening in step 2.
7. Place the cleaned element in the cleaner and secure it with the wing nut.
8. Remove the evacuator valve (5) and clean it with compressed air.
9. Press the button of the dust indicator (1) in and return the piston showing the color red to the original position.

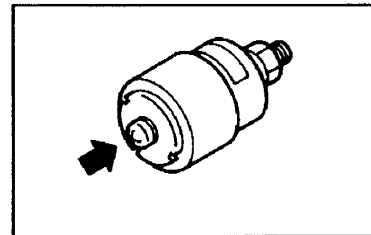

■ Replacing the element

1. Open the rear engine hood and center hood and remove partition panel (2).
2. Remove wing nut (3) and remove element (4). Cover the air connector side behind the body of the air cleaner with a clean cloth or tape to prevent dirt from getting in.
3. Clean the inside of the body of the air cleaner. Remove the cloth or tape that you placed on the air connector opening in step 2.
4. Place a new clean element in the cleaner and secure it with the wing nut.
5. After replacing the element press the button of the dust indicator (1) in and return the piston showing the color red to the original position.

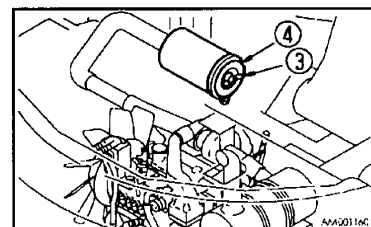
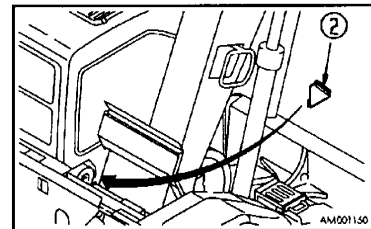

■ **Cracks in rubber track shoes**

Repair cracks in rubber track shoes when they grow to be 60 mm in length. However track shoes that have small short cracks in which the steel cord can be seen should be repaired immediately.

There is no need to repair cracks that are less than 30 mm long or that are less than 10 mm deep.

Consult with Komatsu or your Komatsu dealer about the criteria for replacing, repairing or continuing to use rubber track shoes.

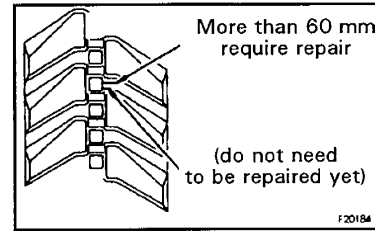

25.2.11 Adjusting Bucket clearance

Warning!

It is dangerous if the arm and boom apparatus is accidentally moved while adjusting bucket clearance. Place the arm and boom apparatus where it is stable and will not move, stop the engine and lock the control levers securely.

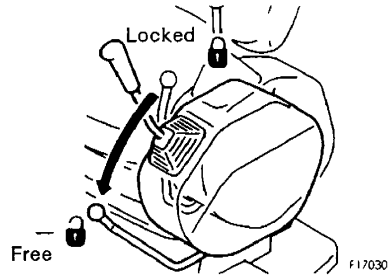

1. Place the arm and boom apparatus in the position shown in the diagram to the right. Stop the engine and place the safety lock lever in the locked position
2. Move the O-ring (1) out of place on the link and measure the play (a). It is easier to measure if you move the bucket to one side so that the play is all in one place (in the diagram the bucket is on the right side). You can measure this accurately and easily with a feeler gauge.
3. Loosen the 4 bolts that hold the plate (2) and loosen plate (3). You can do this without removing the bolts completely because the shims are the split type.
4. Remove shims (4) corresponding to the amount of play (a).

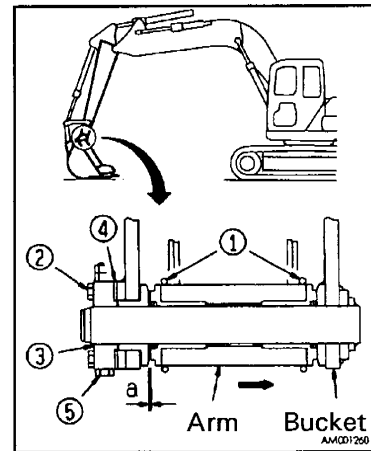

Example

If the amount of play is 3 mm, remove 2 sets of 1.0 mm shims (4) and 1 set of 0.5 (2) and the play will be 0.5 mm.

Four sets of 1.0 mm (8 pieces) shim, 2 sets of 0.5 mm (4 pieces) shim are installed. Two pieces make one set. Do not calibrate when the play is less than one shim.

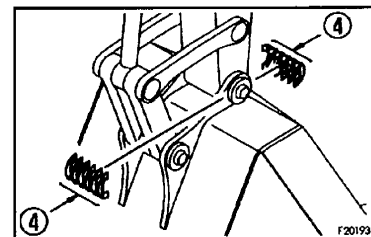

5. Tighten 4 bolts (2). If the bolts (2) are too stiff to tighten, remove the pin stopper bolt (5) and they will be easier to tighten.

25.5.2 Check and replenish the oil in the swing machinery case

⚠ Warning!

Oil is hot after operating the machine. Begin this operation after the oil has cooled down.

1. Open the engine hood and the center hood. Open the cover in the bottom of the tool box.
2. Remove the dipstick (G) and wipe it off with a rag.
3. Reinsert the dipstick (G) as far as it will go.
4. Remove the dipstick. If there is oil on the dipstick (G) between H and L, the level is satisfactory.
5. If the level is below L. Reinsert the dipstick and add engine oil at filler port (F). Remove the air bleeder plug (2) while adding oil.

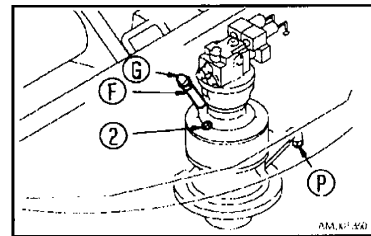
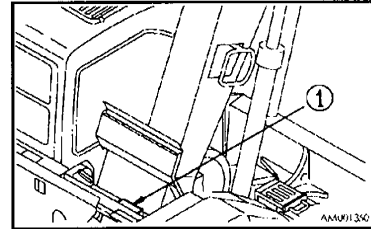

For the oil to use see item 21. "Use of fuel and lubricants by ambient temperatures"

6. If the level is above H, loosen the drain plug (P) and remove the excess oil.
7. After checking and replenishing the oil, reinsert the dipstick and reinstall the drain plug (2).

25.7.2 Check and replenish the amount of grease in the swing pinion

- Have a scale available for this procedure.
- 1. Remove bolts (2) on the top of the revolving frame and remove cover (2).
- 2. Insert a scale in the grease and check to see whether the amount of grease in the portion where the pinion passes is at least 28 mm high. If it is below this level add grease.
- 3. Check to see whether the grease is milky white. If it is the grease should be replaced. Seek the assistance of Komatsu or your Komatsu dealer for this service.

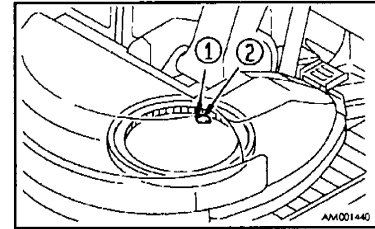

The total volume of grease is 10 ℓ (9 kg)

4. Re-install cover (2) with bolt (1).

25.7.3 Grease the swing circle (2 points)

1. Place the arm and boom apparatus on the ground.
2. Grease the grease fittings indicated by the arrows in the diagram on the right with a grease gun.
3. Wipe up old grease that was forced out after finishing the greasing.

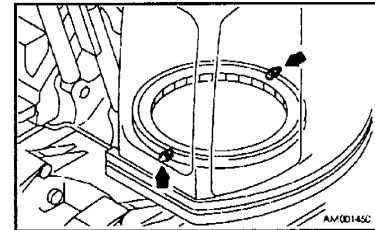

3. Bleed air from the cylinders

- 1) Run the engine at a low idle, and extend and retract each cylinder without going all the way to the end of the stroke (stop at approximately 100 mm from the end of the stroke)
- 2) Next, move each cylinder to the end of its stroke 3 or 4 times.
- 3) Then move each cylinder to the end of its stroke 4 or 5 times and bleed the air out completely.

NOTICE

If the engine is initially run at high RPM and the cylinders are allowed to go to the end of their strokes, the piston packing etc. will be damaged by the air in the cylinder.

4. Bleed the air from the swing motor

(Do this only when the oil has been replaced in the swing motor case)

- 1) Run the engine at a low idle, loosen air bleeder plug (1) and make sure that oil oozes out from the air bleeder plug (1) (this signifies that air has been bled out)

NOTICE

Do not swing the superstructure and arm and boom apparatus at this time.

- 2) If oil does not ooze out, stop the engine, remove air bleeder plug (1) and fill the motor case with hydraulic fluid.
- 3) After the air has been completely bled out, re-insert air bleeder plug (1) and tighten.
- 4) Run the engine at a low idle and swing the superstructure and arm and boom apparatus slowly and steadily to the right at least 2 times.

NOTICE

Failure to bleed the air from the oil in the swing motor may damage the bearings in the motor.

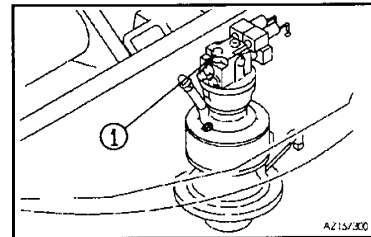

28. GENERAL PRECAUTIONS

28.1 SAFETY PRECAUTIONS

Use of attachments that have not been authorized by Komatsu will not only adversely affect the proper operation of the machine and the useful life of the machine but may also create safety problems. If you are going to install attachments that are not in this manual consult with Komatsu or your Komatsu dealer in advance. Komatsu will not be responsible for any injuries, accidents or equipment breakdowns that are caused by the use of unapproved attachments if you do not contact them in advance.

⚠ Warning!

Precautions in installing and removing

Observe the following precautions when removing and installing attachments and perform the operation safely.

- Remove or install attachments on firm, level ground.
- If the operation is to be done together by 2 or more persons, decide on signals in advance and follow them during the operation.
- Use a crane to carry heavy objects (weighing more than 25 kg.)
- When removing heavy parts, always support the object before removing it. When hoisting such heavy parts with a crane, be careful of the location of the center of gravity.
- It is dangerous to perform an operation while a heavy object remains suspended from the crane. Always have a platform or stand available and check that it is safe.
- When removing attachments or installing them, make sure that they are placed in a stable position so that they will not fall over.
- Never get under a load that is suspended from a crane. Be in a safe place away from the load so that if it falls there is no danger.

NOTICE

The person operating a crane must have the necessary qualifications. Persons without proper qualifications cannot operate them. For details concerning the removal and installation operations seek the assistance of Komatsu or your Komatsu dealer.

31.4 USING RUBBER PAD TRACKS

When using rubber pad tracks, always observe the following precautions in handling.

- **Work site conditions**
 - Use rubber pad tracks mainly for work on paved surfaces. If used on surfaces other than pavement, the rubber will tear and crack and durability will drop significantly. In particular avoid working under the following conditions:
 - On broken concrete fragments or on gravel
 - On sharp protruding things like iron rods and glass (especially pilings that have been driven into the ground)
 - Over the edge of shoulders of concrete roads, on the surface of rocks or river beds with many rocks.
 - Be careful of slipping on road surfaces covered with water, ice, snow or gravel. Be particularly careful of this when unloading the vehicle.
 - Because of the physical properties of rubber, use rubber pad tracks between -25°C to 65°C.

- **Operating Conditions**
 - Operations such as those shown in the diagram in which there is a significant strain on the tracks, side digging operations, operations on slopes and driving and frequently changing direction will place an undue burden on the rubber and cause damage.
 - When special kinds of arm and boom apparatuses are installed the durability of the rubber cannot be guaranteed.

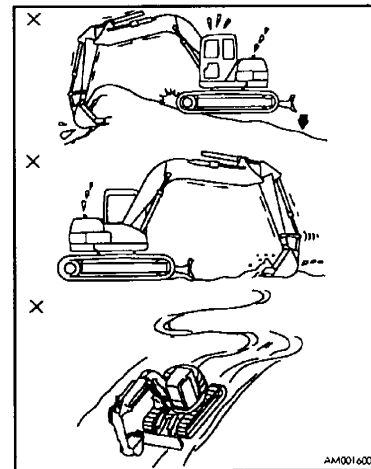

31.5.3 Troubleshooting the automatic leveling system

When error codes other than for the standard vehicle (those of the 4 systems) are displayed on the display of the monitor panel, refer to the table below.

Error code	Problem phenomenon	Chief cause	Corrective measure
42	Cannot excavate automatically	Defective bucket potentiometer	Normal operations can be performed but should be checked immediately
44		Defective inclination gauge	
64		Defective automatic excavation solenoid	
82	Cannot dump arm	Defective arm dump EPC solenoid	After moving the machine to a safe place with the override switch, have it checked immediately
84	Cannot excavate automatically	Defective bucket excavation EPC solenoid	Normal operations can be performed but should be checked immediately
88		Defective bucket excavation EPC solenoid	
A1		Defective boom H pressure sensor	
A2		Defective boom B pressure sensor	
A4		Defective boom H pressure sensor	
A8	Defective boom B pressure sensor		

CLICK HERE TO **DOWNLOAD** THE COMPLETE MANUAL

- Thank you very much for reading the preview of the manual.
- You can download the complete manual from: www.heydownloads.com by clicking the link below



- Please note: If there is no response to CLICKING the link, please download this PDF first and then click on it.

CLICK HERE TO **DOWNLOAD** THE COMPLETE MANUAL