

DECLARATION CE DE CONFORMITE  
AVEC ANNEXE POUR REFERENCE A CERTIFICAT DELIVRE PAR  
ORGANISME COMPETENT  
**EC DECLARATION OF CONFORMITY**  
WITH ANNEX REFERING TO A CERTIFICATE DELIVERED BY  
A COMPETENT BODY

Fabriquant : AGCO S.A.  
*Manufacturer*

Adresse : Avenue Blaise Pascal, 60026 BEAUVAIS - FRANCE.  
*Address*

Nom du signataire : Jonny Frolli  
*Signatory's name*

Qualité : Directeur  
*Quality*

Description du produit : Tracteur agricole  
*Product description*

Le produit identifié ci-dessus est déclaré conforme aux dispositions de :  
*The identified product hereover is declared conform to the requirements of*

- La Directive 75/322 modifiée par la Directive 2000/2 du 14 janvier 2000 et la directive 2001/3 du 8 janvier 2001 relative aux tracteurs agricoles ou forestiers à roues.
- Directive 75/322 modifiée by the Directive 2000/2 from 14 January 2000 and the directive 2001/3 from 8 of January 2001 relating to wheeled agricultural or forestry tractors.

en raison de la délivrance par un ORGANISME COMPÉTENT DU CERTIFICAT EN ANNEXE.  
*due to the delivery by a Competent Body of the Certificate in annex.*

Lieu : Beauvais  
*Location*

Signature :  
*Signature*



ANNEXE A DECLARATION CE DE CONFORMITE  
ANNEX TO A **EC DECLARATION OF CONFORMITY**

Fabriquant : AGCO S.A.  
*Manufacturer*

Adresse : Avenue Blaise Pascal, 60026 BEAUVAIS - FRANCE.  
*Address*

Identification du produit : Tracteur agricole  
*Product Identification*

La conformité aux exigences de la Directive 2001/3 est reconnue pour le produit identifié ci-dessus par :  
*The Conformity to the requirements of the 2001/3 Directive of the hereover identified product is recognised by:*

- Organisme compétent : UTAC  
*Competent body*
- Adresse : Autodrome de Linas  
93311 MONTLHERY - FRANCE  
*Address*

qui a délivré le certificat dont les références sont :  
*who delivered the certificate which references are*

- Numéro du certificat : UTAC e13\*75/322\*2001/3\*2278  
*Certificate number*
- Date (Approbation LCIE) : 05/04/04  
*Date*

CLICK HERE TO **DOWNLOAD** THE COMPLETE MANUAL

- Thank you very much for reading the preview of the manual.
- You can download the complete manual from: [www.heydownloads.com](http://www.heydownloads.com) by clicking the link below



- Please note: If there is no response to CLICKING the link, please download this PDF first and then click on it.

CLICK HERE TO **DOWNLOAD** THE COMPLETE MANUAL

# 1 . TRACTOR IDENTIFICATION

## 1.1 - SERIAL NUMBER

**IMPORTANT: WHEN CONTACTING YOUR DEALER OR AGENT, ALWAYS INDICATE YOUR TRACTOR SERIAL NUMBER.**

Registration plate (according to country)



Fig. 1

Name plate with serial number (according to country).

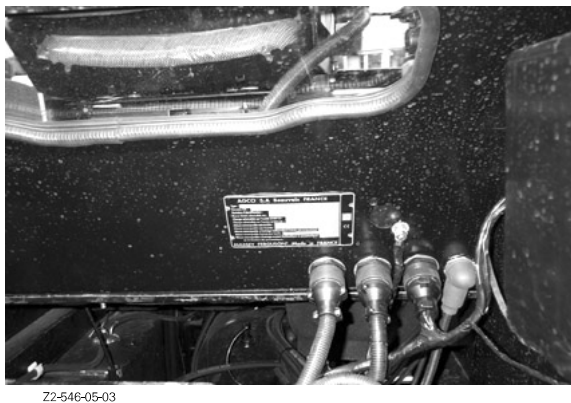

Fig. 2

Front axle Serial number

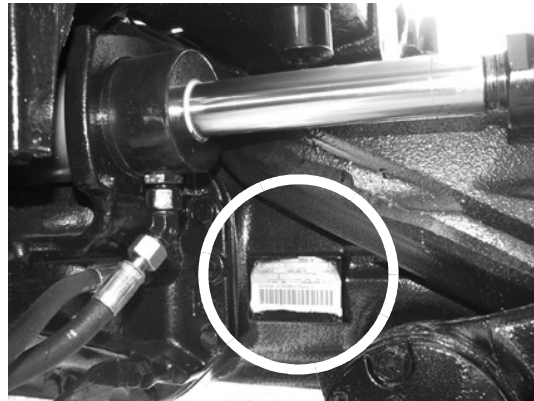

Fig. 3

"Perkins" engine serial number

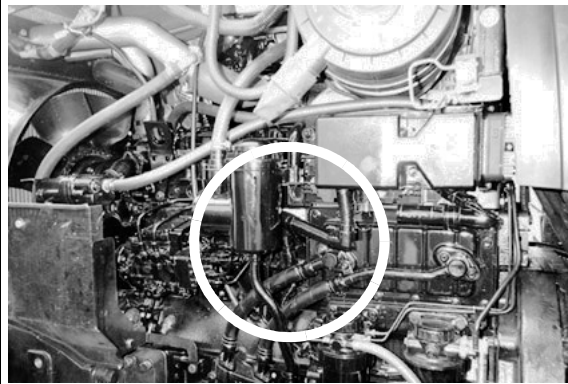

Fig. 4

Cab serial number



Fig. 5

1

## 2 . INTRODUCTION - SAFETY INSTRUCTIONS AND WARRANTY

### 2.8.2 - Observe the following instructions

- **DO NOT ALLOW** children or unqualified persons to operate your tractor. Keep others away from the working area.
- Always wear your seat belt securely fastened.
- Where possible, avoid operating the tractor near ditches, embankments and holes. Reduce speed when turning, crossing slopes, and on rough, slippery, or muddy surfaces.
- Stay off slopes too steep for safe operation.
- Watch where you are going, especially at row ends, on roads, and around trees.
- Instructor seat is only intended for short periods of use
- Do not allow children in the instructor seat.
- **DO NOT PERMIT** others to ride on the tractor or the implement unless an approved instructor seat is fitted.
- Only hitch attachments and implements to the drawbar and hitch points recommended, and never above the centre line of the rear axle.
- Operate the tractor smoothly - no jerky turns, starts or stops. When the tractor is stopped, apply the parking brake securely. Lower the implement and remove the ignition key.
- **DO NOT MODIFY OR REMOVE** any part of the equipment and **DO NOT USE** attachments unless they are properly matched to your tractor.

## 2.9 - PROTECTION

### 2.9.1 - Cab

The ROPS (Roll Over Protective Structure) cab has been designed for this tractor series and meets all the safety and sound legal requirements.

The ROPS cab conforms to the various international safety standards. The ROPS cab must **NEVER** be drilled or modified to install accessories or implements. Welding on cab components is **NOT PERMITTED**. **DO NOT ATTACH** chains or ropes to the main frame of the ROPS cab for pulling purposes.

If additional controls or displays are to be added to the operator's area contact your AGCO dealer for information.

The ROPS cab together with the seat belt is effective in reducing injuries during overturn accidents. Wearing the seat belt is an important part of this protection.

- Always wear your seat belt adjusted snugly.
- Check the seat belt for damage. A damaged seat belt must be replaced (Fig. 1).



Fig. 1

2

### 2.9.2 - Damage to the ROPS cab

If the ROPS cab has been damaged as a result of tractor rollover or incident, it must be replaced, NOT repaired. **DO NOT USE** the tractor with a damaged ROPS cab.

## 2.10 - PREPARING FOR SAFE OPERATION

### 2.10.1 - Know your equipment

It is important to know the tractor and operation of all its accessories, implements and additional equipment. It is also important to know how to use all the controls, gauges and dials, as well as the rated load capacity, speed range, braking and steering characteristics, turning radius, and operating clearances.

Remember that rain, snow, ice, loose gravel, soft ground, etc. can change the performance of your tractor.

*Under poor conditions, slow down and be extra careful, and engage four-wheel drive if fitted.*

Study the **DANGER**, **WARNING** and **CAUTION** safety symbols on your tractor and the information signs also.

## 2 . INTRODUCTION - SAFETY INSTRUCTIONS AND WARRANTY

### Description of decals

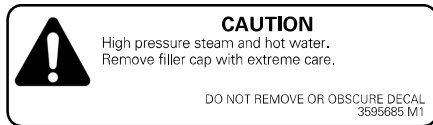

Located on top of the bonnet (access to radiator cap).

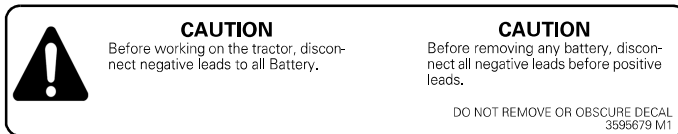

Located on the battery cover.



Located on the right- and left-hand sides of the bonnet.

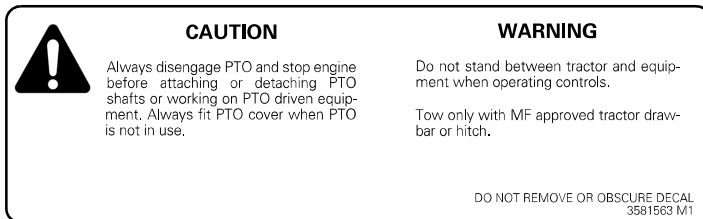

Located at the rear of the tractor.



Located to the left and right of the radiator.



Located on the seat belt.

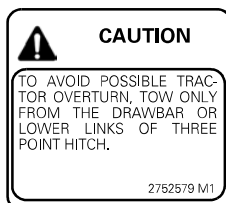

Located on the fenders to the rear of the cab.



Located on the RH inner column of the cab.

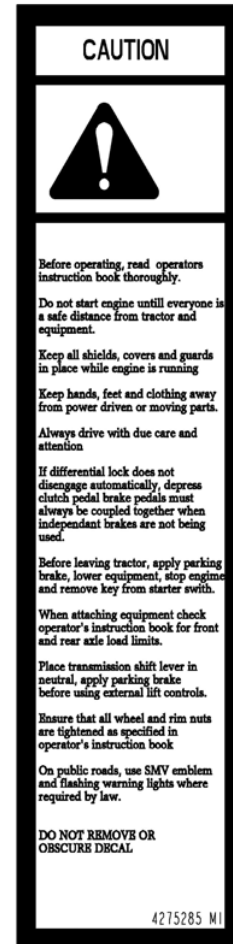

Located on the RH inner column of the cab.



Located on the accumulator.

### Failure control warning lights

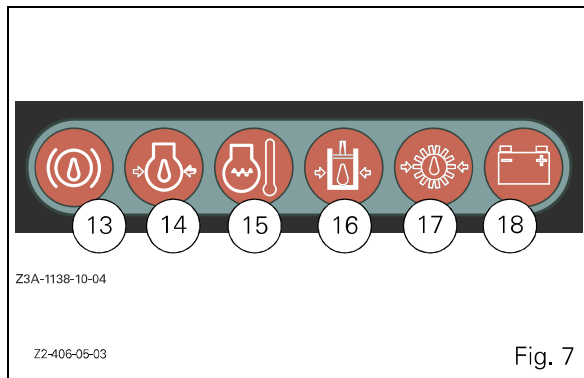

Fig. 7

13. Trailer air brake pressure indicator light (if fitted) (red).
14. Engine oil pressure indicator light (red).  
This indicator light is switched on when the ignition key is in "auxiliary" position. It switches off when the engine starts running. If the indicator light comes on when the engine is running, stop the engine and investigate the cause of the problem immediately.  
Check for low oil level or consult your dealer.
15. Coolant temperature indicator light (red).
16. Booster pressure indicator light (LS) on high pressure filter.
17. Gearbox oil pressure indicator light (red).  
If this warning light gets on during operation, consult your agent or dealer.
18. Alternator charge warning light (red).

### 3.3 - CONTROL DISPLAY

Fig. 8- This control screen allows the different parameter displays to be monitored:

1. Forward/neutral/reverse liquid crystal display.
  2. Reverse shuttle sensitivity indicator.
  3. Selected symbols display: rear PTO/engine speed/forward ground speed:  
All parameters that can be displayed in the lower part of the screen can be selected by pressing button 5 (Fig. 9) located on the instrument panel.
  4. Digital display: Rear PTO speed/engine speed/forward ground speed/working time.
- NOTE:** To reinitialise hours worked, select the relevant parameter and hold the button 5 (Fig. 8) down for approximately 5 seconds to reset the display.
5. Front power take-off automation.
  6. Front axle automatic functions monitor.
  7. A/B speed (engine with electronic fuel injection) memorisation status.
  8. Hare/Tortoise range engagement indicator lights.

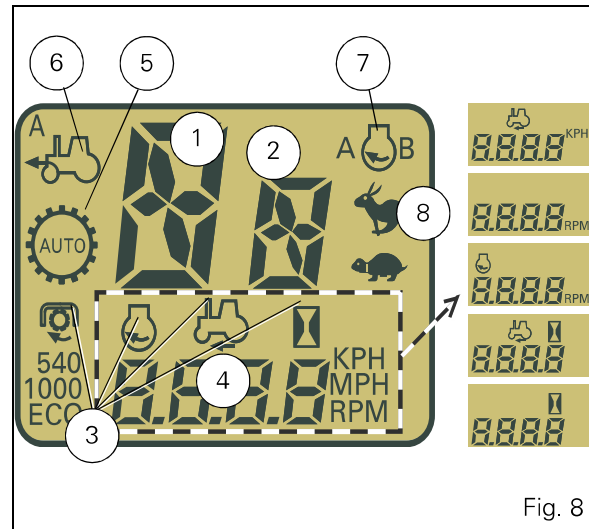

Fig. 8

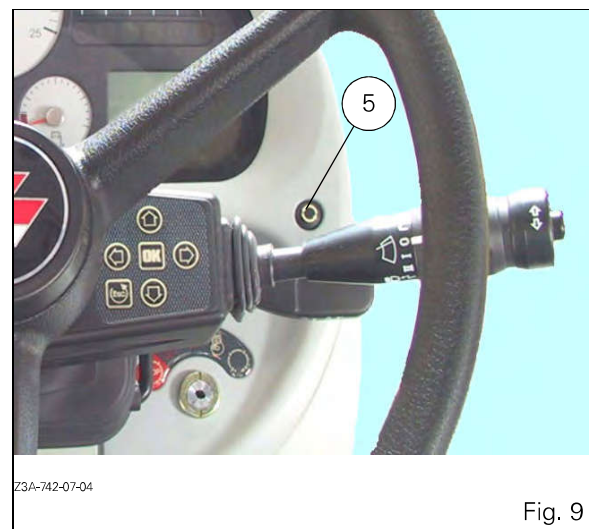

Fig. 9

## 3 . INSTRUMENTS AND CONTROLS

### 3.10.5.4 - Preselecting the cab temperature

Preselect the required temperature with knob 6. The preselected value is displayed on the LCD screen (2).

To change the display from Celsius to Fahrenheit:

- Switch off the ignition key.
- Move the fan switch 1 to OFF position.
- Move temperature knob 6 to maximum heat position (red).
- Switch on ignition key and within 5 seconds press the defrosting button 4 and air recycling button 5 simultaneously.
- The temperature symbol (°C ou °F) will appear on the LCD screen.

When there is a problem or error, an "E" is displayed to warn the user (contact your dealer to determine the cause of the problem).

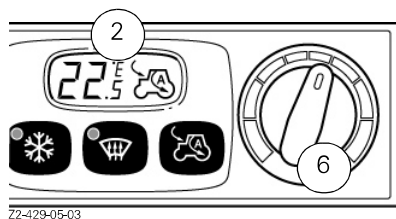

### 3.10.5.5 - Maximum temperature

To reach maximum temperature, adjust the cab temperature gauge to over 28°C.

Air conditioning is ON (A/C LED is lit)

- HI is displayed on the LCD screen.



### 3.10.5.6 - Minimum temperature

To reach minimum temperature, adjust the cab temperature gauge to under 18°C.

Activating the compressor (A/C LED is lit)

- LO is displayed on the LCD screen.

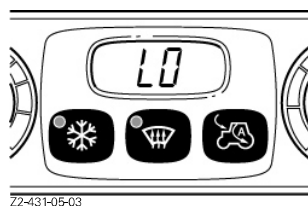

### 3.10.5.7 - Defrosting function

This function is activated by pressing button 4 (approximate time: 3 minutes).

The relevant indicator light comes on.

To switch off the defrost option and return to the previous condition, press the defrost switch again (the LED 4 is switched off), or once the 3 minutes have passed.

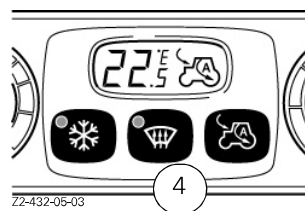

The compressor is activated (A/C LED is lit)

- HI is displayed on the LCD screen.



### 3.10.5.8 - Air flow adjustment

When fan control knob 1 is in auto position (A), air flow is selected automatically. Air flow change is gradual.

It is possible to manually select an air flow different to the air flow selected automatically. When the knob position is changed, air flow change is instantaneous.

Depending on the level of solar radiation, the air flow adjusts automatically if the required temperature is lower than the outside temperature, and the LCD temperature display flashes.

Air flow can be adjusted to maintain the temperature inside the cab at preselected levels.

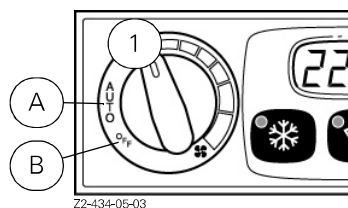

### Stopping the automatic function

Move the fan button 1 to the OFF position (B).

## 4 . OPERATION



Fig. 5

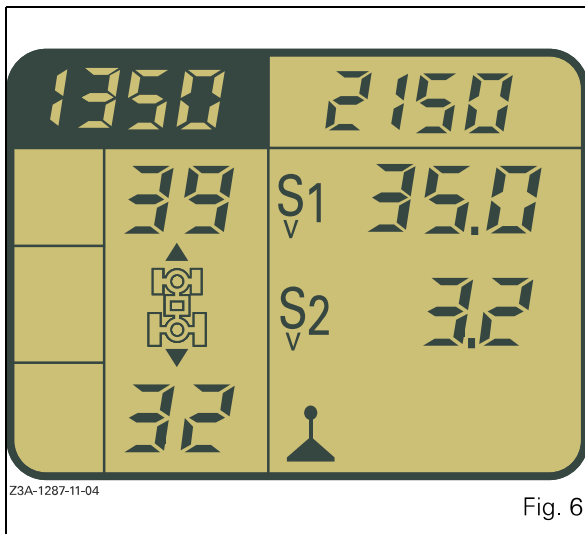

Fig. 6

- The engine symbol appears on the digital display, along with the letter A or B, indicating the active memorised engine speed (e.g.: memorised speed A (2 Fig. 7)).

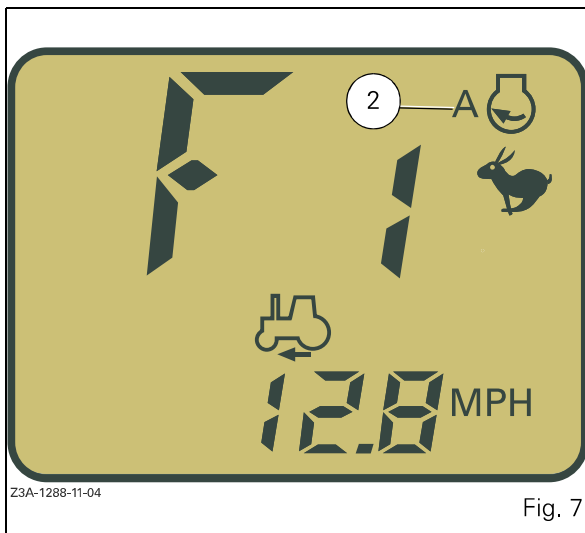

Fig. 7

**IMPORTANT:** When driving at a preselected accelerated engine speed, press once on the key A/B or on the brake pedals, or quickly press the throttle pedal (kick down) to automatically drop to idle speed.

### 4.4.3.1 - Range shifting

To shift from "Hare" range or from "Tortoise" range (button on console) engage the required range by keeping the gear shift switch 1 pressed until the ratio is fully engaged (the corresponding indicator light will light up on the instrument panel).

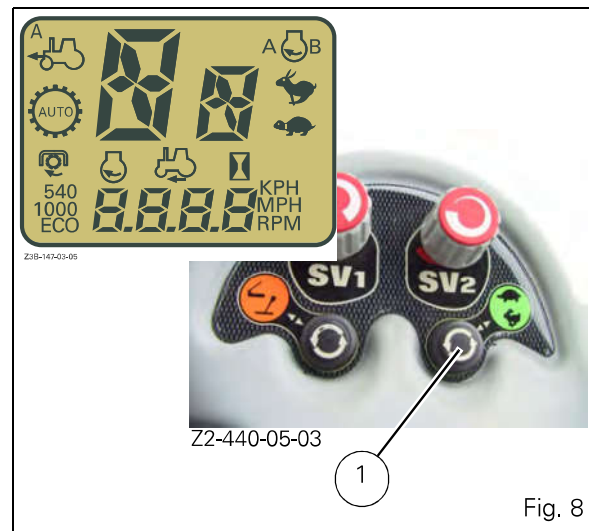

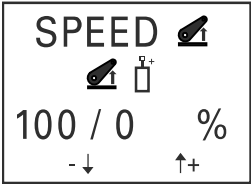
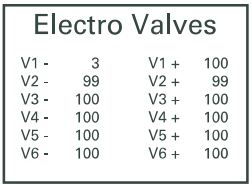

Fig. 8

**NOTE:** Do not rush when carrying out this manoeuvre. The "Hare to Tortoise" synchronised range change is only possible when the tractor is stationary and the clutch pedal is pressed down. The "Tortoise to Hare" change is only possible at speeds above 5 kph.



**DANGER:** Before leaving the seat it is mandatory to move the power shuttle control to NEUTRAL position and engage the hand-brake.

**NOTE:** If the tractor is working in conditions where water comes higher than the wheel hubs, corrosion damage can occur to some of the components. Consult your dealer or agent for sealing precautions. Failure to do so can invalidate the warranty.

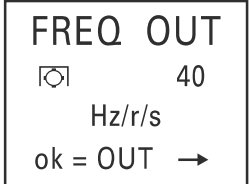
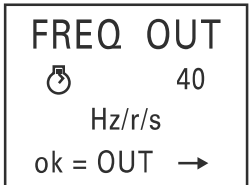
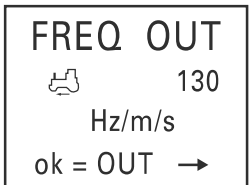
Screens	Access	Function
 <p style="font-size: small; margin-top: 5px;">Z3A-1311-11-04</p>	<p style="text-align: center;">→</p> <p>To display from the previous screen</p> <p style="text-align: center;">↑ ↓</p> <p>To modify displayed linkage and spool valve flow rate values</p>	<p style="text-align: center;"><b>Linkage and EHS valves menu</b></p> <p>This menu allows to give priority to the auxiliary spool valves over the linkage, and vice versa.                      Maximum linkage value: 100%                      Minimum spool valve value: 0%                      Minimum linkage value: 1%                      Maximum spool valve value: 99%</p>
	<p style="text-align: center;">→</p> <p>To display from the previous screen</p>	<p style="text-align: center;"><b>Valves display screen (if Datatronic 3 option is not installed)</b></p> <p>Allows flow rate of each valve to be displayed</p>
 <p style="font-size: small; margin-top: 5px;">Z3A-1312-11-04</p>	<p style="text-align: center;">→</p> <p>To display from the previous screen</p>	<p style="text-align: center;"><b>Error code screen</b></p> <p>Displays all of the tractor error codes. Each error code is displayed for 4 seconds in a loop.</p>
 <p style="font-size: small; margin-top: 5px;">MA-11-06144A</p>	<p style="text-align: center;">→</p> <p>To display from the previous screen</p> <p style="text-align: center;">OK</p> <p>Used to change the reference speed (next screen).</p> <p style="text-align: center;">→</p> <p>To exit the PTO speed output adjustment menu</p>	<p style="text-align: center;"><b>PTO speed output adjustment screen (models fitted with electronic injection)</b></p> <p>Used to adjust the PTO speed reference frequency (40 to 60), (consult your dealer for details of connection and value adjustments)</p>
 <p style="font-size: small; margin-top: 5px;">MA-11-06145A</p>	<p style="text-align: center;">OK</p> <p>Used to change the reference speed (next screen).</p> <p style="text-align: center;">→</p> <p>To exit the Engine speed output adjustment menu</p>	<p style="text-align: center;"><b>Engine speed output adjustment screen (models fitted with electronic injection)</b></p> <p>Used to adjust the engine speed reference frequency (40 to 60), (consult your dealer for details of connection and value adjustments).</p>
 <p style="font-size: small; margin-top: 5px;">MA-11-06146A</p>	<p style="text-align: center;">OK</p> <p>Used to modify the reference speed (next screen).</p> <p style="text-align: center;">→</p> <p>To exit the Frequency menu</p>	<p style="text-align: center;"><b>Ground speed output adjustment screen (models fitted with electronic injection)</b></p> <p>Used to adjust the current speed reference frequency (36 to 144), (consult your dealer for details of connection and value adjustments).</p>

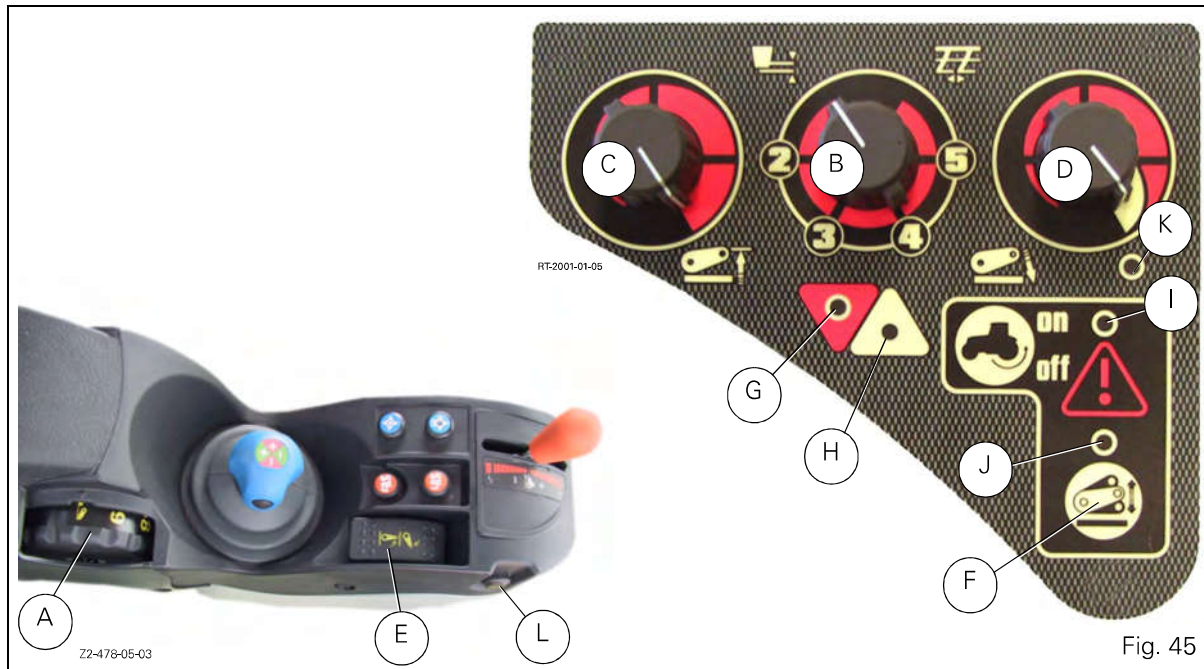

Fig. 45

### 4.12.6 - Transport

- Select the minimum position with the knob B, Fig. 45.
- Adjust the maximum linkage height according to the transport implement using the height setting button C. Start from minimum position. Move the knob D to position 1 (padlock).

### 4.12.7 - Activate transport control system

- The system operates automatically when button F is pressed; indicator light J comes on.
- To deactivate this function, press button F.

### 4.12.8 - Quick soil engagement

- Move the selector switch E to Down position, press and hold button L to trigger quick soil engagement.
- Release as soon as the plough is engaged into the soil.

### 4.12.9 - Use when working

- Adjust the maximum high position using knob C.
- Using knob D, adjust a maximum linkage lowering speed.
- Choose the implement control mode (Draft, Position or Intermix), according to the implement, the ground conditions and the type of work, by use of the control selector knob B.
- Adjust the working depth using knob A.
- The Lift and Lower indicator lights H and G allow to display the work being carried out.

### 4.12.10 - Operation at headlands

Put the Lift/Lower switch E into the lift position. The linkage will rise to the preselected maximum lift position C. In order to resume work, put the Lift/Lower selector switch E into "Lower". The depth settings previously made will be repeated.

**NOTE:** A safety cut-out puts the linkage system out of operation when the ignition is switched off, the engine stopped (ignition switched off), or external controls are used.

The object of this device is to avoid any accidental movement of the linkage if settings on the console have been altered, while the tractor is stationary.

To reactivate the linkage, move the switch E to the intermediate position, then to the lift position.

Linkage is then brought back into operation and the padlock (N Fig. 46) in the Datatronic 3 window disappears, if this latter has been installed.

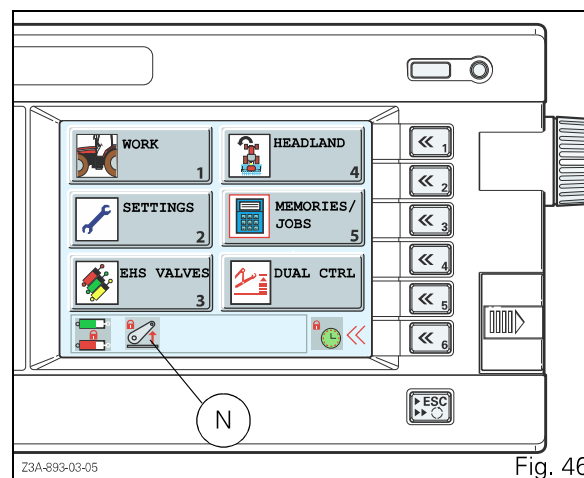

Fig. 46

### 4.16 - TOWING PROCEDURES AND INSTRUCTIONS



**WARNING:** Towing: the following instructions must be followed when towing:

**If the engine is not running:**

- Maximum towing speed: 10 kph.
- Maximum towing distance: 8 kph.

**If the engine is running:**

- Towing speed is identical to that of a trailer without brakes at the speed authorised by legislation in force in the country concerned.

**Towing instructions:**

- Open the cover located on the cab floor (right-hand side) (Fig. 72).



- Remove the protective shield (Fig. 73 and Fig. 74).



- Position the emergency lever on the control unit (C) (Fig. 75).

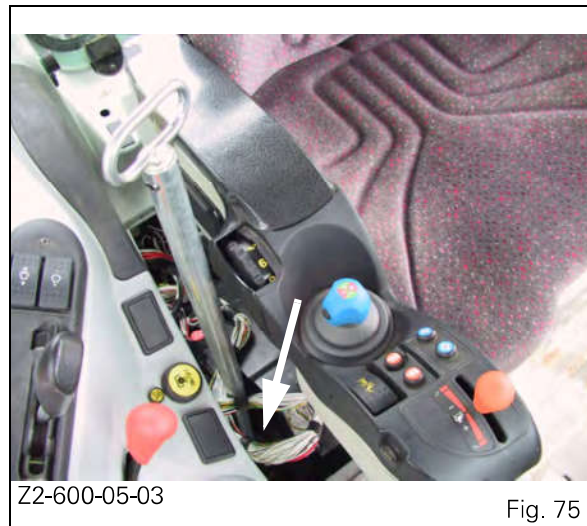

- Move the DYNA VT transmission to neutral position (middle position Ref. 1 Fig. 76).

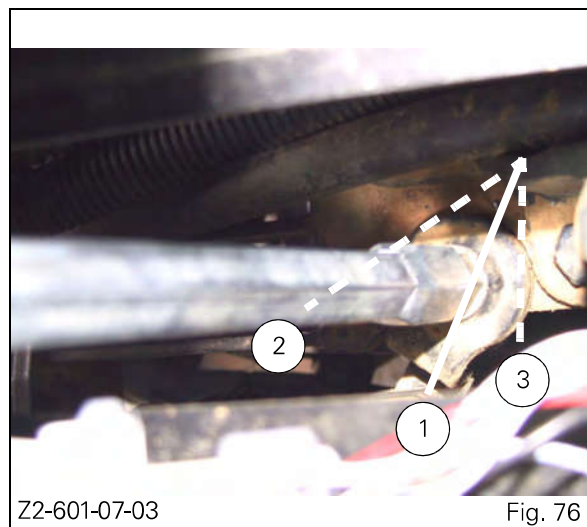

## 5 . MAINTENANCE AND ADJUSTMENTS

SERVICE GUIDE	Inspections according to Service Record Book				
	50h	400h	800h	1200h	2000h
47. Check brake pipes condition.	•			•	
48. Bleed brake circuit.					•
49. Check parking brake adjustment.	•	•	•	•	•
50. Check trailer brake valve for correct operation.	•			•	
51. Check PTO engagement function.	•	•	•	•	•
<b>General</b>					
52. Top up cab windscreen washers.	•	•	•	•	•
53. Clean cab air filter element.		•	•		•
54. Change cab air filter element.				•	
55. Check the air conditioning system operation.	•	•	•	•	•
56. Bleed compressed air circuit water from suspended cab.			Fortnightly		
57. Change cab dampers.			4800H		
58. Check torque of cab / safety frame mounting bolts.	•	•	•	•	•
59. Check torque of all wheel and rim nuts and bolts.	•	•	•	•	•
60. Lubricate all points with grease or oil as specified in the Operator Instruction Book.	•	•	•	•	•
61. Check all safety guards are in place with readable stuck decals.	•	•	•	•	•
62. Road test the tractor to check all transmission controls for correct operation.	•	•	•	•	•
63. Road test the tractor to check the steering and brakes for correct operation.	•	•	•	•	•
64. Operate all PTO and hydraulic services to ensure correct operation.	•	•	•	•	•
65. After road test, check for any leaks of oil, fuel or coolant.	•	•	•	•	•
66. Enquire if the operator has any operational difficulties and correct or demonstrate solution as necessary.	•	•	•	•	•
67. Complete the owner's Service Record Book.	•	•	•	•	•

CLICK HERE TO **DOWNLOAD** THE COMPLETE MANUAL

- Thank you very much for reading the preview of the manual.
- You can download the complete manual from: [www.heydownloads.com](http://www.heydownloads.com) by clicking the link below



- Please note: If there is no response to CLICKING the link, please download this PDF first and then click on it.

CLICK HERE TO **DOWNLOAD** THE COMPLETE MANUAL

## 5 . MAINTENANCE AND ADJUSTMENTS

### 5.12 - STEERING, TRANSMISSION AND AUXILIARY FUNCTIONS

Two circuits carry out the functions. One circuit carries out transmission functions, the other carries out steering and auxiliary functions.

#### 5.12.1 - Transmission and final drive unit hydraulics

##### 5.12.1.1 - Change the transmission oil every 2000 hours

1. Do not drain until the transmission oil is hot.
2. Remove the drain plugs (Fig. 16) and the filler cap (Fig. 17).
3. Refit the drain plugs, then refill the transmission to the correct level with an approved oil.

**NOTE:** Allow time for the oil to settle in the rear axle and transmission before rechecking the level.

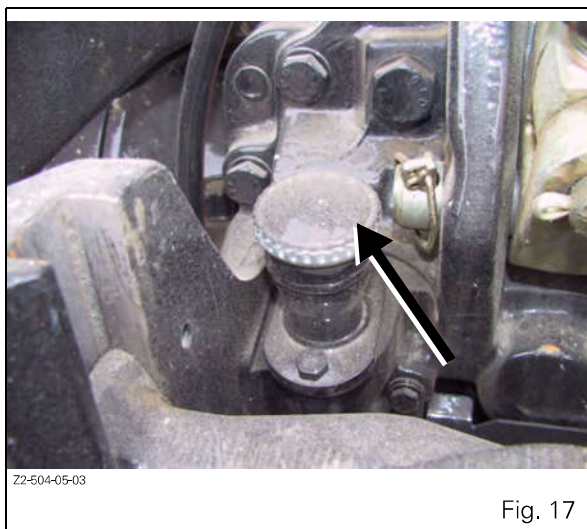
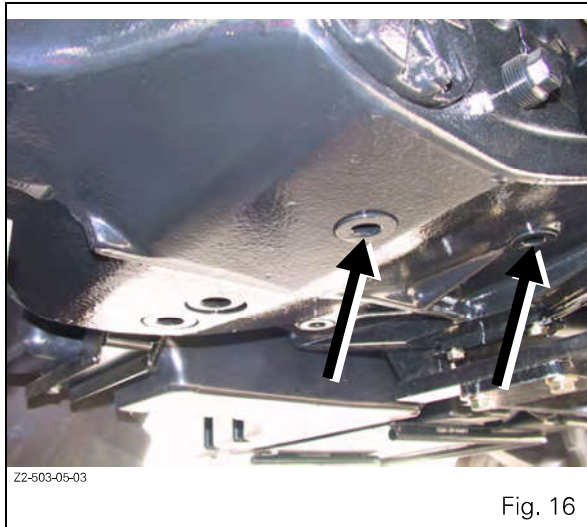

##### 5.12.1.2 - Change the 150 micron suction strainer (Fig. 18) every 2000 hours

Release the three screws from the retainer plate, and extract and discard the strainer.

Fit the new strainer in its place. Fit the retainer plate and tighten the three attachment screws.

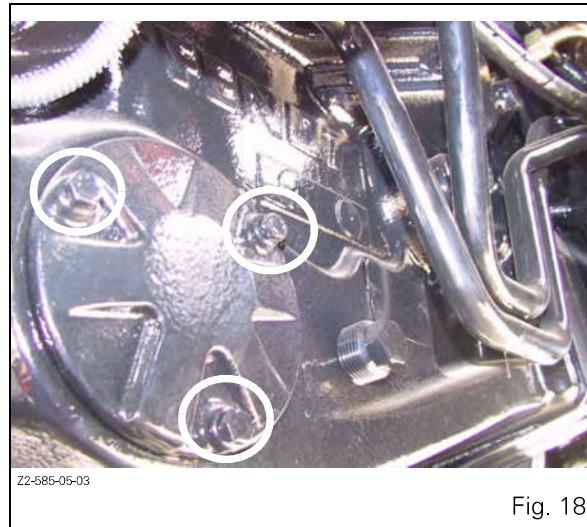

##### 5.12.1.3 - High pressure 10 micron filtering 400 hours the first time, then every 800 hours, replace the high pressure filter element located on the right-hand side of the housing (ref. 1, Fig. 19).

- Unscrew the filter body, pull out the filter element, allow to drain fully, and discard it.
  - Every 800 hours, or as necessary, replace the seal.
  - Slide the new filter element onto the filter head.
- To avoid contamination by foreign material (swarf, sludge, etc.), do not completely remove the protective plastic until the filter element is in place.
- Replace the filter body and screw hand tight until it locks.

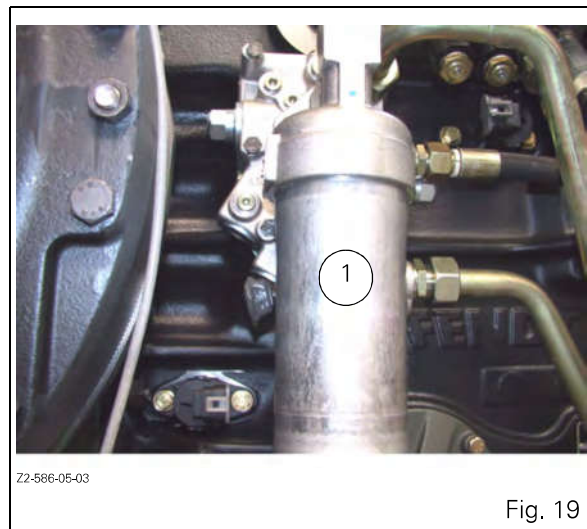

## 5 . MAINTENANCE AND ADJUSTMENTS

---

*NOTE: With narrow track widths and with certain tyre fittings, the wheels may touch the body when turning at maximum lock.*

To prevent this, the hubs are fitted with threaded stops (Fig. 37) which can be adjusted to limit the turning lock. Set maximum front axle oscillation by changing stop 1 itself (Fig. 38). If you change stop, use securing bolt provided in the tool box.

*NOTE: The axle is factory set for tractor transport.*



Z2-520-05-03

Fig. 37

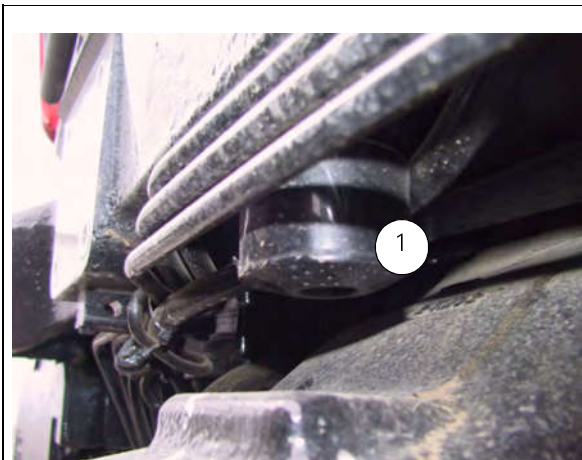

Z2-521-08-03

Fig. 38

*Chapter 6*  
**SPECIFICATIONS**

## 6 . SPECIFICATIONS

### 6.21 - DIMENSIONS AND WEIGHTS

SPECIFICATIONS	7465	7475	7480
<b>A.</b> Wheel base	2780		
<b>B.</b> Overall length with lower links without front weights, max.-min.	4650 - 4500		
<b>C.</b> Height to roof (with cab), max. - min.	3042 - 2705		
<b>D.</b> Max. overall width	2550		
<b>E.</b> Max. - min. ground clearance (under swinging drawbar support)	373 - 606		
Min. weight (with full tank, without counterweight steel wheels)	6154	6266	6302
<b>C. and E.:</b> Dimensions vary according to tyre assembly.			

	Rear axle		Front axle	
	ML 130	20.19	20.22	20.29
<b>F.</b> Distance between flanges: Shaft Ø 95:	- 1716	1800 -	1900 -	1900 -
<b>G.</b> Stud distance:	275	275	335	335
<b>H.</b> Centring diameter:	220,2	220,8	280	280
<b>I.</b> Stud length: Wheel with steel hub: Wheel with cast iron hub:	41 66	36* -	40 -	40 -
<b>J.</b> Stud or screw diameter:	M22x1.5	M18x1.5	M22x1.5	M22x1.5
<b>K.</b> Number of studs or screws:	8	8	10	10
*Front axle not suspended				

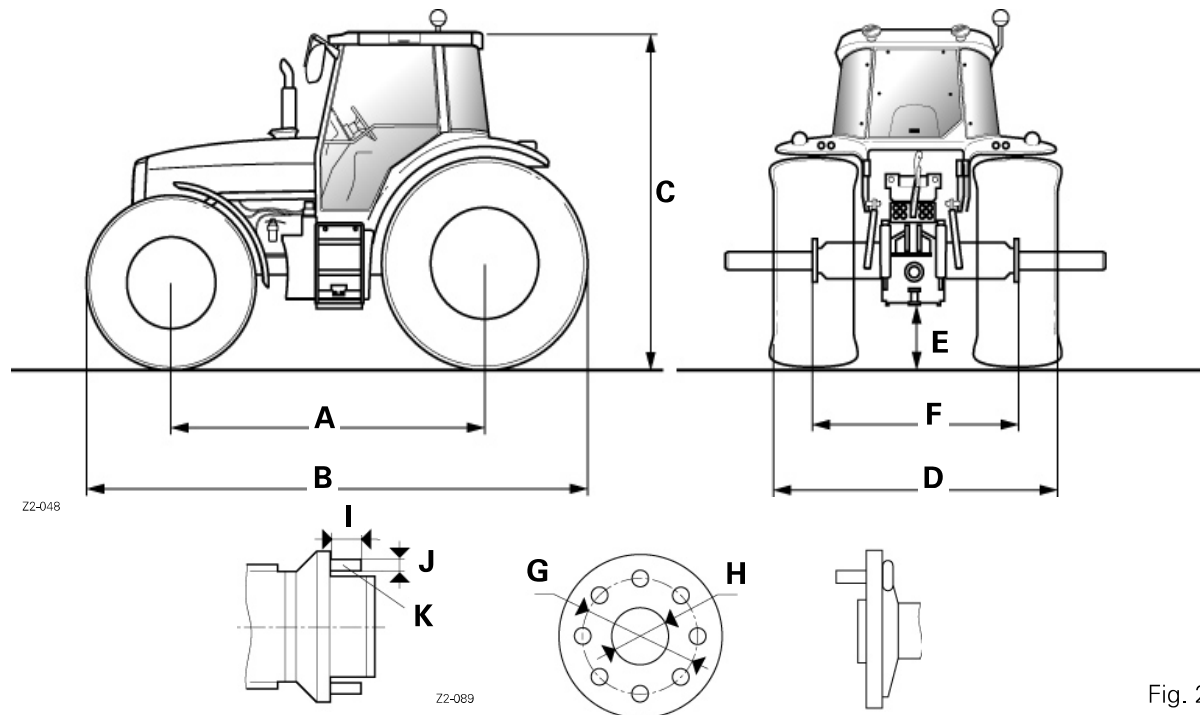

6

Fig. 2

## 7 . ACCESSORIES AND OPTIONS

### Symbols in the right-hand part of the window:

Provides access to the memory naming menu

Resets the values

Used to measure work accomplished, either manually or automatically by means of a sensor (e.g.: the number of trailers)

Provides access to the implement width setting menu

Used to select the event based on which the different values should be measured. (e.g.: as soon as the linkage is lowered)

Activates or deactivates the memory

**NOTE:** If a plough width has been stored previously, the sprayer icon is replaced by a plough icon.

Provides access to the plough width setting menu

### 7.3.3 - Saving an implement name to memory

When the window (Fig. 7) is open, press the key  $\ll_1$  to display the first memory menu. The window (Fig. 8) is displayed.

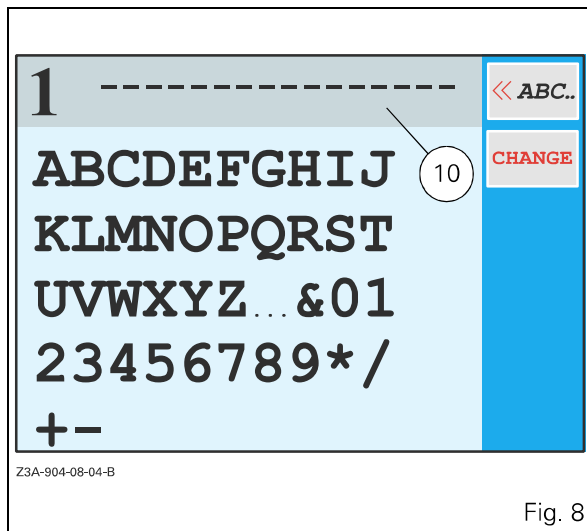

Fig. 8

**NOTE:** If no implement name has been saved, a sequence of hyphens is displayed (10 Fig. 8).

### To enter a new name:

- Press the key  $\ll_1$ . The previously displayed name is erased and the first letter of the alphabet is displayed in red (11 Fig. 9).

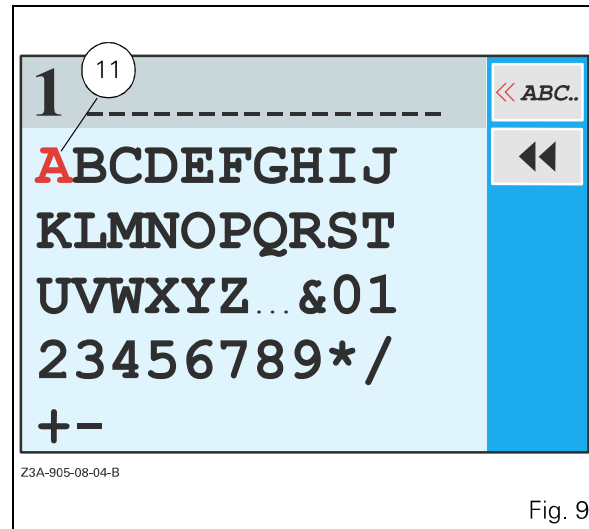

Fig. 9

- Select the first letter to enter by rotating the encoder (e.g.: the P of PLOUGH).
- Validate the letter by pressing the encoder. The letter P is displayed in black (12 Fig. 10).

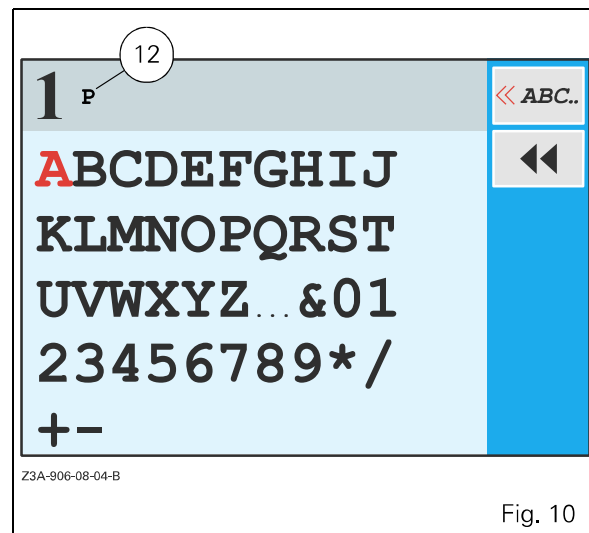

Fig. 10

- Repeat this operation for the remaining letters.
- To change a letter, press the key  $\ll_2$ . The letter to change is replaced by a hyphen (13 Fig. 11).

## 7 . ACCESSORIES AND OPTIONS

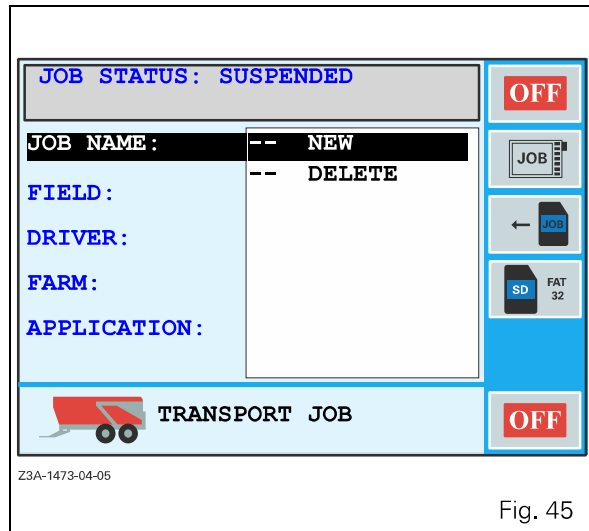

Fig. 45

It is then possible to enter a new name, delete an existing name or use a name that has already been entered.

### 7.3.8.3 - Entering a new name

- When the window (Fig. 45) is open, press the encoder. The window (Fig. 46) is displayed.

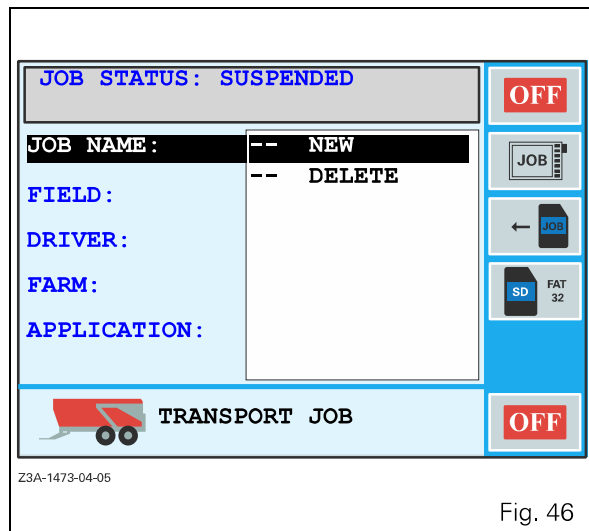

Fig. 46

- Select the letter by rotating the encoder.
- Validate the letter by pressing the encoder.
- Repeat this operation for the remaining letters.
- Press the **ESC** key to validate the word. The window (Fig. 47) is displayed.

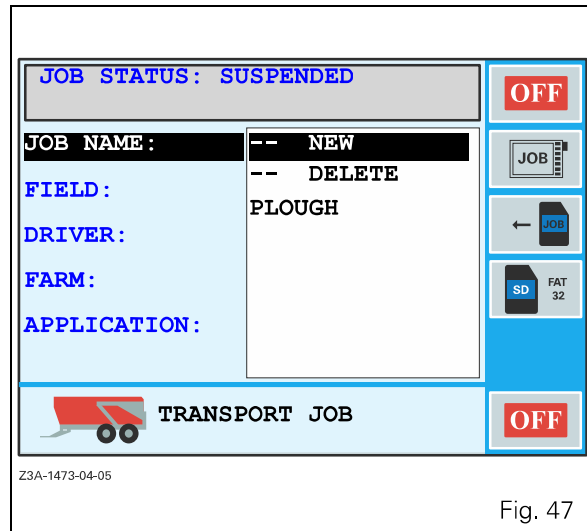

Fig. 47

### 7.3.8.4 - Deleting an existing name

- Select the DELETE line using the encoder when the window (Fig. 45) is open.
- Validate by pressing the encoder. The window (Fig. 48) is displayed.

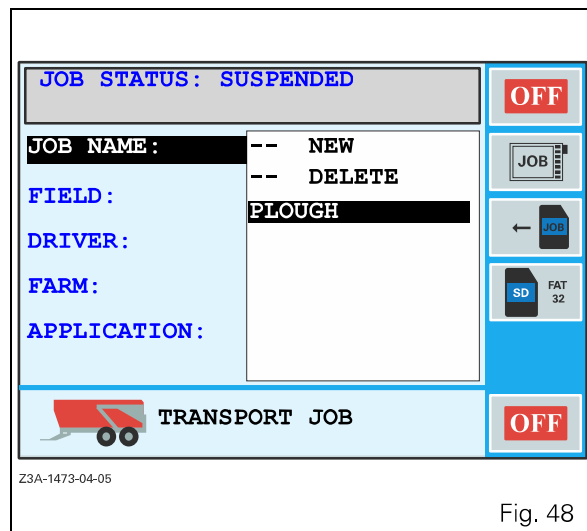

Fig. 48

- Select the name to delete with the encoder.
- Validate by pressing the encoder, and the window is displayed (Fig. 45).

## 7. ACCESSORIES AND OPTIONS

### EHS valve identification:

On colour screens, each EHS valve is identified by a colour matching the colour on each control (Fig. 83).

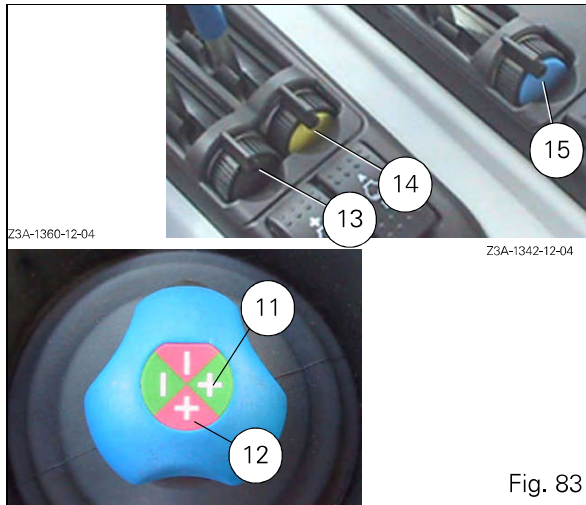

- 11. Green
- 12. Red
- 13. Black
- 14. Yellow
- 15. Blue

### 7.4.2.1 - Dyna VT transmission

Displays the GEARBOX SETTINGS menu in the right-hand window (Fig. 84):

This display is used to view Dyna VT transmission settings.

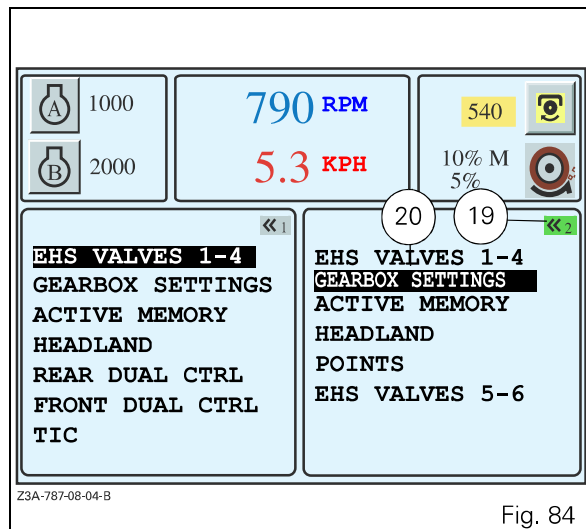

Fig. 84

- To start one of the applications, press the key «<sub>1</sub>, or the key «<sub>2</sub> twice. The first key press selects the window and the second displays the list. The active application is represented by a green button at the top right-hand of the window (19 Fig. 84).
- To call up the various menus, select the application using the encoder. The selected application is displayed in a black frame (20 Fig. 84).

- Validate by pressing the encoder or the key «<sub>2</sub>. The window (Fig. 85) is displayed.

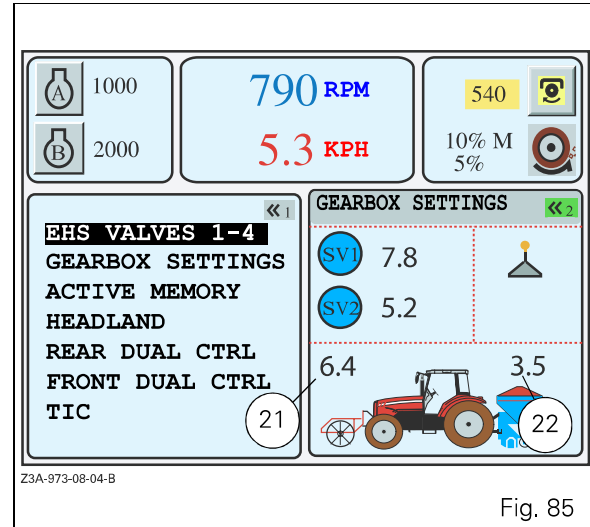







Fig. 85

### Description:

-  SV1 regulator speed value
-  SV2 regulator speed value

- 21 Forward restart speed
- 22 Reverse restart speed

The different transmission control modes:

-  Lever mode
-  Pedal mode (POWER or ECO)
-  Self-propelled mode

**NOTE:** To perform these settings, see chapter 4 (Driving the tractor). If manual mode driving is selected, the "OFF" icon is displayed with the linkage icon.

To set parameters, see section 4.5).

### 7.4.3 - Active memory menu

Displays the ACTIVE MEMORY menu in the left-hand window (Fig. 86):

## 7 . ACCESSORIES AND OPTIONS

### 7.5.4.1 - Adjusting the brightness

- Select the **BRIGHTNESS** menu using the encoder (the window Fig. 118 is displayed).

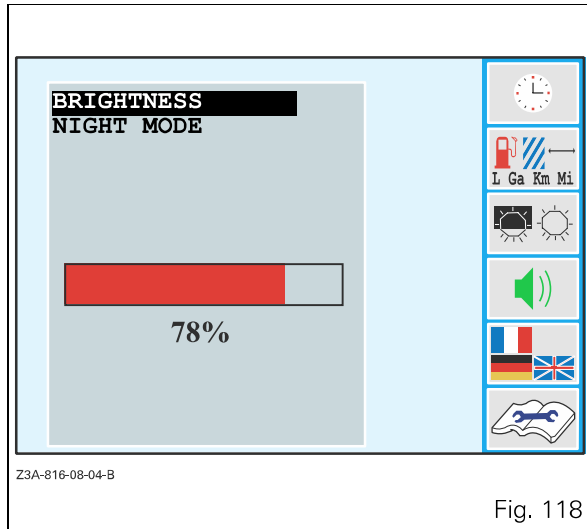

- Adjust the brightness (from 0 to 100%) using the encoder.
- Validate by pressing the encoder. The main menu is displayed.

### 7.5.4.2 - Setting night mode

This mode reduces screen brightness during night time use.

- Select the NIGHT MODE menu using the encoder (the window Fig. 119 is displayed).

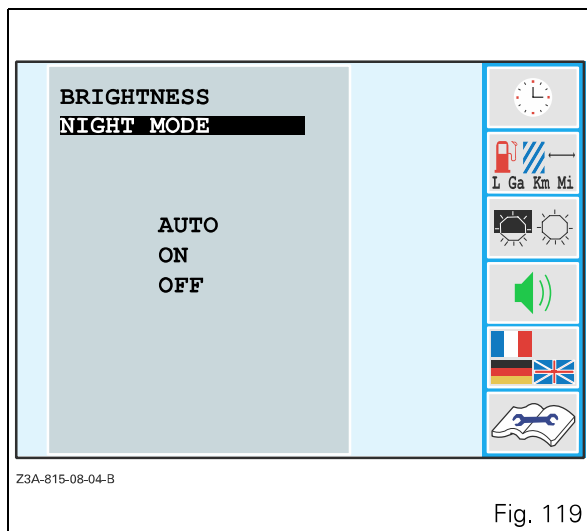

- Using the encoder, select one of the 3 following modes:
- AUTO (night mode is activated when the tractor headlights are switched on),
  - ON (night mode is always active and, in this case, the screen goes dark),
  - OFF (night mode is always deactivated).

As soon as one of the modes is validated, the window (Fig. 120) is displayed.

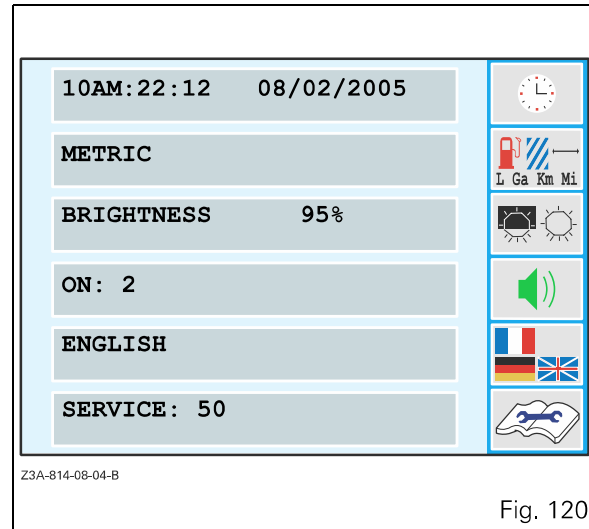

### 7.5.5 - Setting the buzzer volume

- Press the key «4 when the window (Fig. 121) is open. The window (Fig. 122) is displayed.

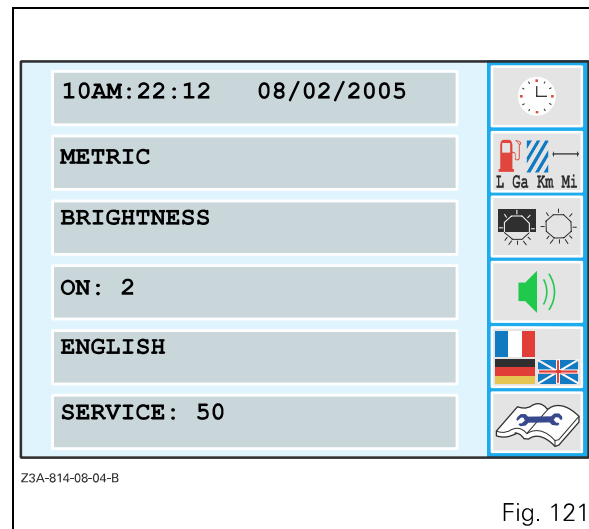

## 7. ACCESSORIES AND OPTIONS

### 7.7 - HEADLAND APPLICATION

#### 7.7.1 - General

This application is used to automatically manage manoeuvres at the end of the field. Using a single button, it is possible to automate all functions in order to avoid activating each control lever or button separately.

When using an implement, a sequence of 35 actions can be recorded from 46 different actions available.

**Description (Fig. 152):**

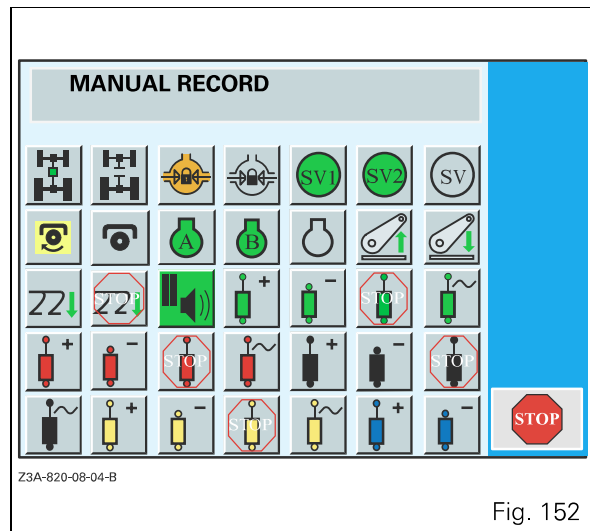

Activate front axle

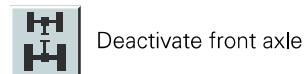

Deactivate front axle

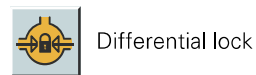

Differential lock

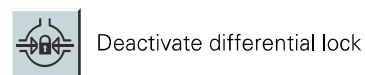

Deactivate differential lock

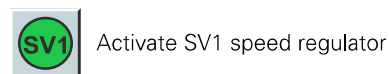

Activate SV1 speed regulator



Activate SV2 speed regulator

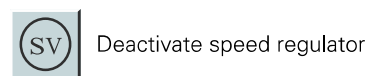

Deactivate speed regulator

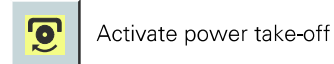

Activate power take-off

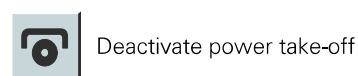

Deactivate power take-off

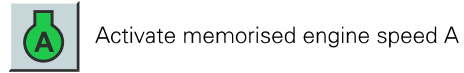

Activate memorised engine speed A

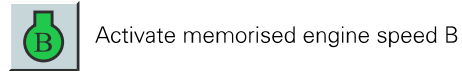

Activate memorised engine speed B



Deactivate memorised engine speed

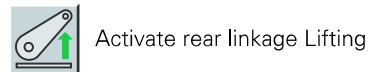

Activate rear linkage Lifting

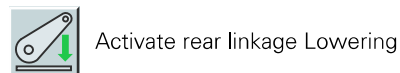

Activate rear linkage Lowering

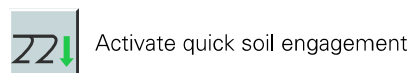

Activate quick soil engagement

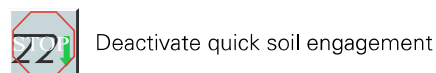

Deactivate quick soil engagement

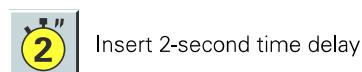

Insert 2-second time delay

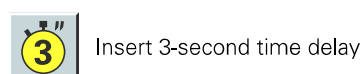

Insert 3-second time delay

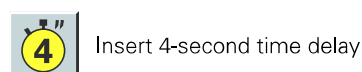

Insert 4-second time delay

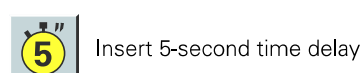

Insert 5-second time delay



Insert pause

For each spool valve:

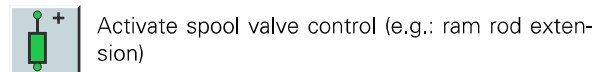

Activate spool valve control (e.g.: ram rod extension)

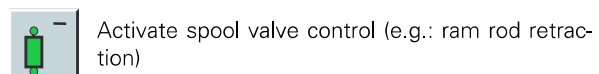

Activate spool valve control (e.g.: ram rod retraction)



Activate spool valve control in neutral position



Activate spool valve control in floating position

## 7 . ACCESSORIES AND OPTIONS

### 7.7.4.2 - Displaying reading in the WORK application

- When the window (Fig. 185) is open, press the key <<3>. The window (Fig. 187) is displayed.

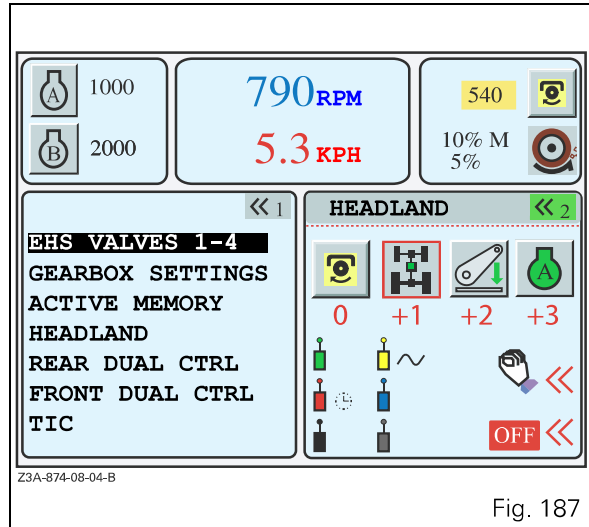

Fig. 187

For the description of this window, see section 7.4.4 Headland menu.

**NOTE:** If a sequence reading operation is active when the window (Fig. 188) is open, the word **HEADLAND** flashes red to alert the driver (25).

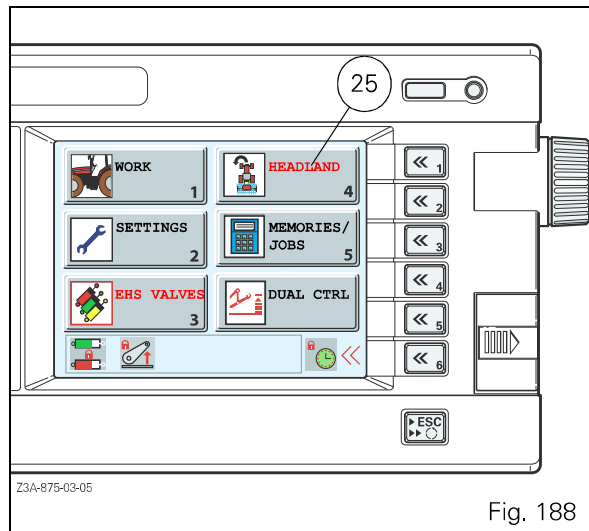

Fig. 188

## 7.8 - DUAL CONTROL APPLICATION

### 7.8.1 - General

The DUAL CONTROL is a system which automatically controls implements in working position and at the end of the field.

It also allows the rear linkage position to be carried over to the front linkage position or to the depth wheel position of a semi-mounted plough for example.

The information necessary for the correct operation of the system is acquired by sensors, processed by the Autotronic 5 linkage calculator, which controls the operation of an electrohydraulic spool valve, and is displayed on the Datatronic 3 onboard computer.

Using this application, the following can be controlled:

- a front and rear implement, with the FRONT DUAL CONTROL (e.g.: a front roller and a combined rear seeder (Fig. 189), a front and rear plough, etc.),
- a semi-mounted rear implement, with the REAR DUAL CONTROL (e.g.: a semi-mounted plough (Fig. 190), a semi-mounted disc tiller, etc., These implements being hitched to the rear linkage),
- a trailed rear implement with the TRAILED IMPLEMENT CONTROL (TIC) (e.g.: a disc tiller (Fig. 191), a trailed chisel, etc. These implements are hitched to the swinging drawbar or lift arms). This system allows the implement height to be set according to the wheel slip and the draft applied to the lift arms (the linkage is fixed).

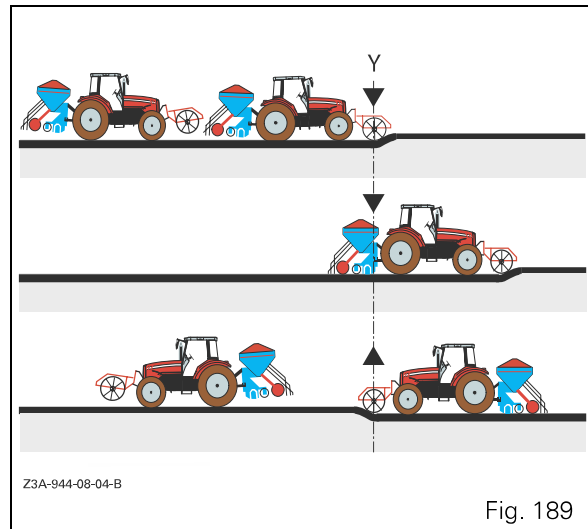

Fig. 189

## 7 . ACCESSORIES AND OPTIONS

### 7.8.2.13 - Working operation

#### Furrow start:

When the tractor is at the start of a furrow, activate the rear linkage Lowering control as soon as the tractor front implement reaches mark Y (29 Fig. 219). The front implement lowers to the extra-lowering value. When distance X has been travelled, the rear linkage lowers automatically (30 Fig. 219). The linkage lifts again to the set depth (31 Fig. 219). The linkage lifts again to the set depth (31 Fig. 219.)

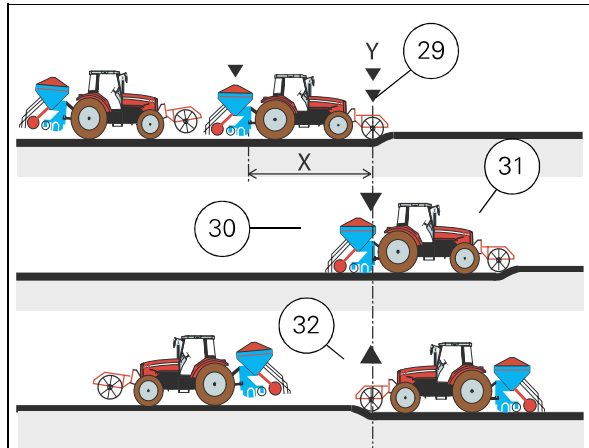

Z3A-946-08-04

#### LEGEND:

- 29. Lowering the front linkage below working position
- 30. Lowering the rear linkage into working position
- 31. Lifting the front linkage into working position
- 32. Lifting of the front linkage

Fig. 219

#### Furrow end:

At the end of a furrow, activate the rear linkage lifting control when the tractor reaches mark Y (32 Fig. 219). The front implement lifts. As soon as distance X has been covered, the rear linkage lifting control is automatically activated.

**NOTE:** For pointed fields, however, the POINTS menu must be used to optimise the operation of the FRONT DUAL CONTROL (see section 7.8.5, POINTS menu).

**IMPORTANT:** If the linkage high and low stops are modified during work, they are not stored in the Datatronic 3 active memory. To store them, see section 7.8.2.5, Memorising high and low linkage positions.

#### Displaying parameters:

During work either the Settings window (Fig. 220), or the Work window (Fig. 221) can be displayed.

As the front and rear linkage positions change, the corresponding height values change in the white boxes.

The values in the grey boxes are memorised and fixed.

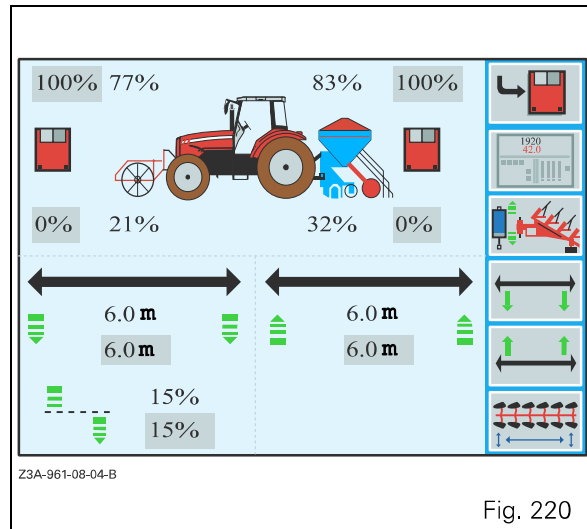

Z3A-961-08-04-B

Fig. 220

#### Description (Fig. 221):

To display this window, press the key <<2 when the window (Fig. 220) is open.

#### Left-hand part of the window:

The linkage position values (33) are the active values.

The symbols under the linkages (34) indicate their control status.

#### Right-hand part of the window:

See the description in section 7.8.5, POINTS menu.

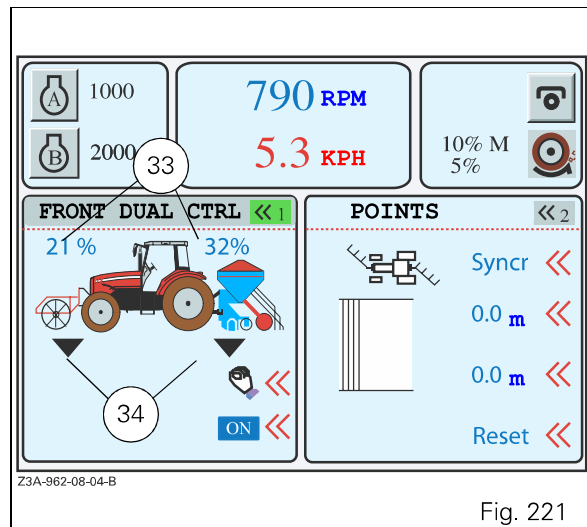

Z3A-962-08-04-B

Fig. 221

## 7 . ACCESSORIES AND OPTIONS

- Memorise the high position by pressing the key <<1. The high position value is displayed in the greyed box and is memorised.

### Memorising the low position:

- Place the disc tiller in working position (Fig. 250) using a linkage cylinder spool valve control.

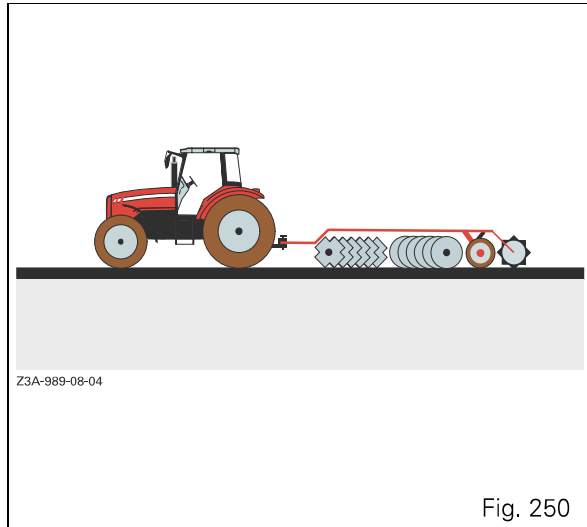

Fig. 250

- Memorise the work position by pressing the key <<3. The memorised work position value is displayed in the grey box.

### 7.8.4.5 - Activating the TIC function

In order to use the TIC function, it must first be activated.

- Press the key <<2 When the window (Fig. 252) is open. The window (Fig. 251) is displayed.

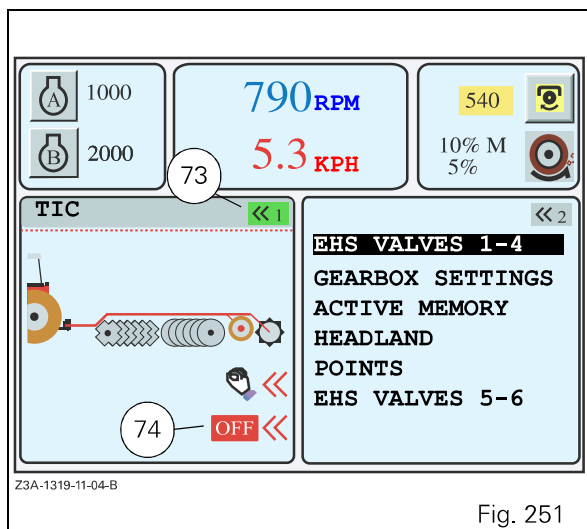

Fig. 251

- Press the key <<6 when the icon (73 Fig. 251) is green (if this is not the case, first press the key <<2 so the icon (73 Fig. 251) is displayed in green.

- The TIC function is then active and the symbol (74 Fig. 251) changes from OFF to ON.

### 7.8.4.6 - Working operation

To activate disc tiller Lifting or Lowering, use the rear linkage control. When the TIC is in use, the linkage is inactive and locked.

As soon as the implement is in working position, wheel slip, implement depth and the draft applied to the lift arms are analysed by the calculator, which varies the implement working height accordingly.

**IMPORTANT:** If the linkage high and low stops are modified during work, they are not stored in the Datatronic 3 active memory. To store them, see section 7.8.4.4, Memorising high and low linkage positions.

### Displaying parameters:

During work either the Settings window (Fig. 252), or the Work window (Fig. 253) can be displayed.

### Description (Fig. 252):

As the disc tiller position changes, the high and low position values vary accordingly in the white boxes.

The values in the grey boxes are memorised and hence fixed.

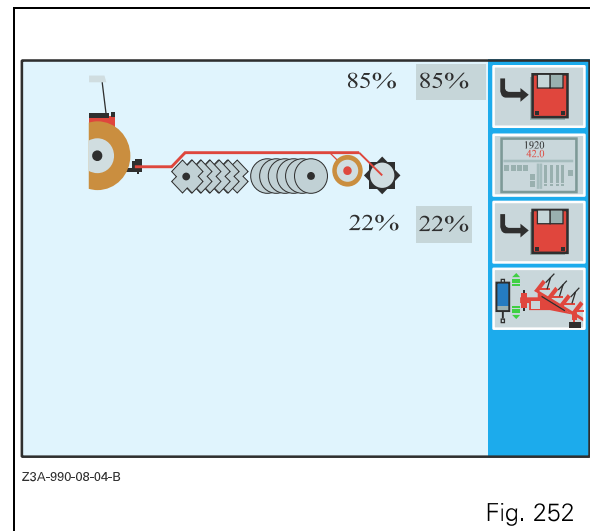

Fig. 252

### Description (Fig. 253):

To display this window, press the key <<3 when the window (Fig. 252) is open.

### Left-hand part of the window:

- 75. Active disc tiller position value.
- 76. Indicate the spool valve control status.

CLICK HERE TO **DOWNLOAD** THE COMPLETE MANUAL

- Thank you very much for reading the preview of the manual.
- You can download the complete manual from: [www.heydownloads.com](http://www.heydownloads.com) by clicking the link below



- Please note: If there is no response to CLICKING the link, please download this PDF first and then click on it.

CLICK HERE TO **DOWNLOAD** THE COMPLETE MANUAL