

# Tigercat<sup>®</sup>

## BAR SAW FELLING HEAD

### OPERATING AND SERVICE MANUAL

SERIAL NUMBER 51850101 to 51850500

SERIAL NUMBER 51950101 to 51950500



**ISSUE 2.0** OCTOBER, 2014

**Tigercat Industries Inc.**

P.O. Box 637  
Brantford, Ontario  
Canada N3T 5P9

Tel: (519) 753-2000

Fax: (519) 753-8272

CLICK HERE TO **DOWNLOAD** THE COMPLETE MANUAL

- Thank you very much for reading the preview of the manual.
- You can download the complete manual from: [www.heydownloads.com](http://www.heydownloads.com) by clicking the link below



- Please note: If there is no response to CLICKING the link, please download this PDF first and then click on it.

CLICK HERE TO **DOWNLOAD** THE COMPLETE MANUAL

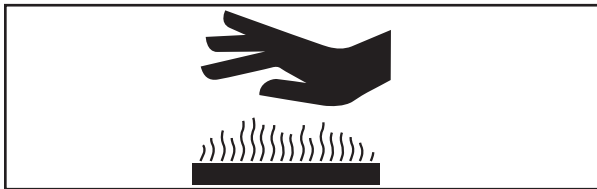
**GENERAL SAFETY PRECAUTIONS**  
continued

Be aware when performing service and maintenance tasks that surfaces and grab handles in and around the engine and cooling system may become very hot when the engine has been running. Contact with hot surfaces may cause injury.

Comply with instructions in this manual and also your company's regulations for the operation of this machine.

 **WARNING**

**Engine exhaust, some of its constituents, and certain vehicle components contain or emit chemicals known to the State of California to cause cancer and birth defects or other reproductive harm.**

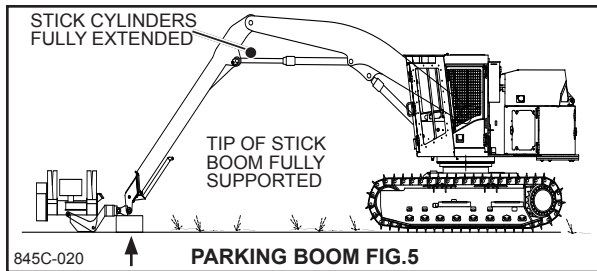

Before beginning any service work on the felling head, place the machine on level ground, place the attachment on the ground in the position required for the work being done and properly support the boom.



Always install the tilt lock bolts when servicing the head in an upright position. Tilt locks are also used to position felling head properly for shipping. Refer to SHIPPING FD5195 USING SHIPPING SUPPORT, RIGGING AND STRAP in SECTION 2 of the OPERATOR'S MANUAL.



If the engine is running inside a building, ensure that sufficient ventilation is available to prevent a build-up of toxic exhaust fumes. Run the engine only when it is necessary for testing or adjustments.

Work in a ventilated area. If it is necessary to run an engine in an enclosed area, use an exhaust pipe extension to remove toxic exhaust fumes.

If you don't have an exhaust pipe extension, either work outside, or open the shop doors.

## SAFETY LABELS

### BAR SAW FELLING HEAD

The following safety labels are installed on the felling head. All labels must be periodically cleaned and inspected to ensure legibility is maintained. Replace any label that becomes illegible, damaged or removed.



### READ AND UNDERSTAND THE OPERATOR'S MANUAL.

This label informs you that before operating this head, **CAREFULLY** read and understand the operator's manual completely. Observe the instructions and safety rules. If an operator does not follow instructions and safety rules, they expose themselves as well as any bystanders to unnecessary hazards. Keep the manual in a safe and easily accessible location for future reference. There is one of these labels located on the felling head, on the left side of the main frame. Only trained and qualified personnel should operate this equipment.

**DO NOT OPERATE THE MACHINE** until you have read and thoroughly understand the operator's manual and the fundamentals of operating the machine.



### READ OPERATOR'S & SERVICE MANUALS

This label informs you that before starting any service work you must stop the engine, **REMOVE THE IGNITION KEY**, store it in a safe place, and consult the operator's manual and service manual for proper service procedures. Operating, servicing or making machine adjustments without fully understanding how the machine works can result in damage to the machinery, serious injury or death. Only trained and qualified personnel should service this equipment.

There is one of these labels located on the felling head, on the left side of the main frame.

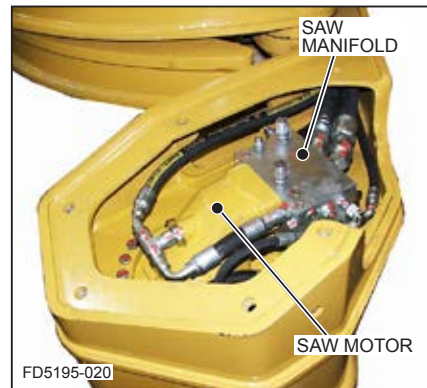
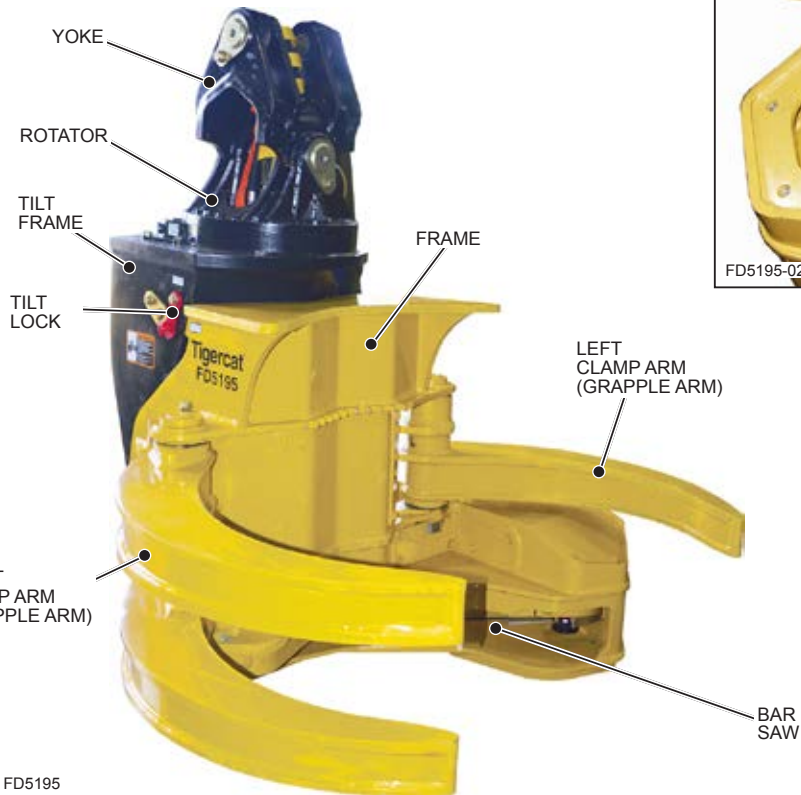
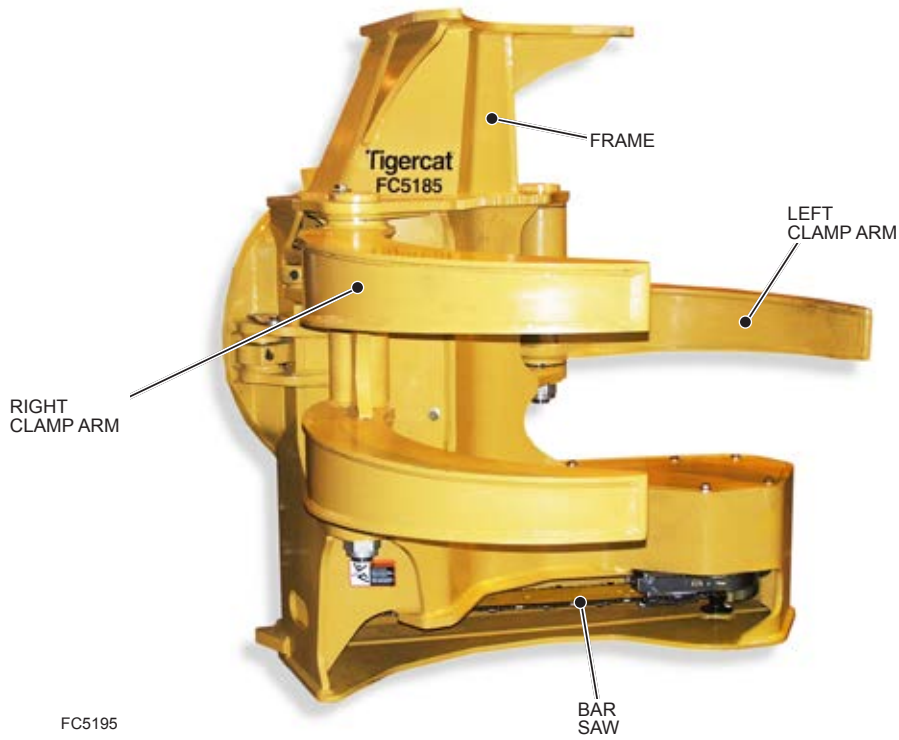

**BAR SAW COMPONENTS**



### TILT FRAME FD5195

The tilt frame carries the felling head and provides a means of positioning the head when approaching trees through rotation and tilt angle.

Two hydraulic cylinders, one on each side of the tilt frame are used for the tilt function.

### TILT FRAME LOCK BOLTS FD5195

The tilt frame is equipped with two service locking bolts. The lock bolts, one on each side of the attachment, are used to lock the attachment in the upright position when performing service such as lubrication or repairs and for shipping.

When not in use the lock bolts are stored in the lock bolt hole storage location on the attachment frame.



LEFTHAND SIDE TILT FRAME LOCK STORAGE POSITION



LEFTHAND SIDE TILT FRAME UPRIGHT LOCKED POSITION

CLICK HERE TO **DOWNLOAD** THE COMPLETE MANUAL

- Thank you very much for reading the preview of the manual.
- You can download the complete manual from: [www.heydownloads.com](http://www.heydownloads.com) by clicking the link below



- Please note: If there is no response to CLICKING the link, please download this PDF first and then click on it.

CLICK HERE TO **DOWNLOAD** THE COMPLETE MANUAL

<b>Recommended Chain Oil</b>				
<b>Viscosity</b>	<b>Supplier</b>	<b>Brand Name</b>	<b>Pour Point</b>	<b>Flash Point</b>
200 cSt @ 40°C	ESSO	HD Chain Oil (Summer)	Minus 15°C max	260°C
60 cSt @ 40°C	ESSO	Light Chain Oil (Winter)	Minus 33°C max	200°C

<b>Recommended Lubricants</b>				
<b>Esso</b>	<b>Shell</b>	<b>Mobil</b>	<b>BP</b>	<b>Petro Canada</b>
Beacon	Alvania	Mobilux	EPEnegrease	Supreme
EP - 2	EP - 2	EP - 2	EP - 2	EP - 2

CHAIN OIL.XL

5. Tighten the long pin nut and torque to specifications. The clamping plate should be tight. If problems are encountered it may be due to sawdust or other debris. It will be necessary to disassemble and clean the bar holder.

### REPLACING SAW CHAIN, MANUAL TENSION

1. Park machine on firm level ground with the boom fully extended and the head positioned firmly on the ground and tilted back for access to the saw unit.
2. Turn pilot switch OFF, engage swing brake (track machines), engage parking brake (wheeled machines) and shut engine OFF. Block tracks or wheels.
3. Release the clamping plate BEFORE adjusting the chain tension.

Loosen the long pin nut, tap the bottom of the pin to loosen the pin and release the clamping plate.

4. Turn the adjusting nut counter clockwise to loosen chain.
5. Replace chain.  
If problems are encountered due to sawdust or other debris it may be necessary to disassemble and clean the bar holder.
6. Adjust chain tension. Refer to ADJUSTMENT OF MANUAL CHAIN TENSION.
7. Operate the saw carefully a few times to ensure proper operation.

### REPLACING SAW BAR, MANUAL TENSION

1. Park machine on firm level ground with the boom fully extended and the head positioned firmly on the ground and tilted back for access to the saw unit.
2. Turn pilot switch OFF, engage swing brake (track machines), engage parking brake (wheeled machines) and shut engine OFF. Block tracks or wheels.
3. Remove the saw chain. Refer to REPLACING SAW CHAIN in THIS SECTION.
4. Loosen the long pin and short pin nuts enough to allow the bar plate to drop down releasing the bar from the bar pins at the tail of the bar. It may be necessary to move the bar up and down to release it.

### CAUTION

**Changing the saw bar, saw chain, cleaning, lubrication or other maintenance must never be done while the machine's engine is running.**

**Always ensure that the engine is OFF**

**Remove chain when making adjustments or servicing the saw unit.**

**Always use protective gloves when working with saw chain and hydraulic oil.**

5. Clean out any sawdust or other debris to ensure a proper installation.
6. Install the new bar ensuring the tail of the bar engages the two bar pins. Tighten the short pin nut and torque to specifications.
7. Replace saw chain. Refer to REPLACING SAW CHAIN in THIS SECTION.

# Tigercat Bar Saw Felling Head

# Lubrication , Maintenance and Service

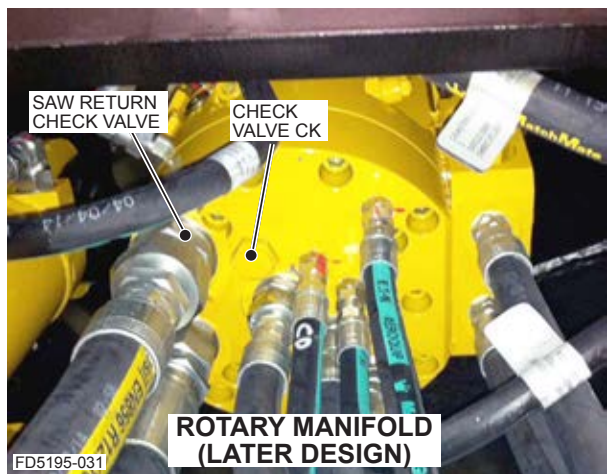
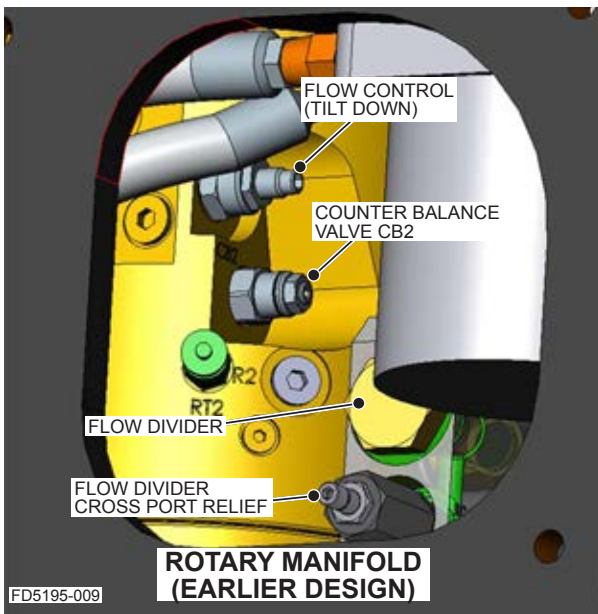
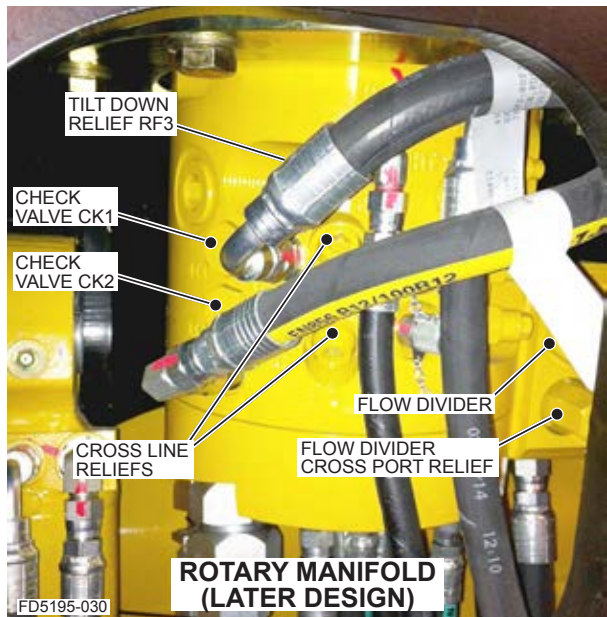
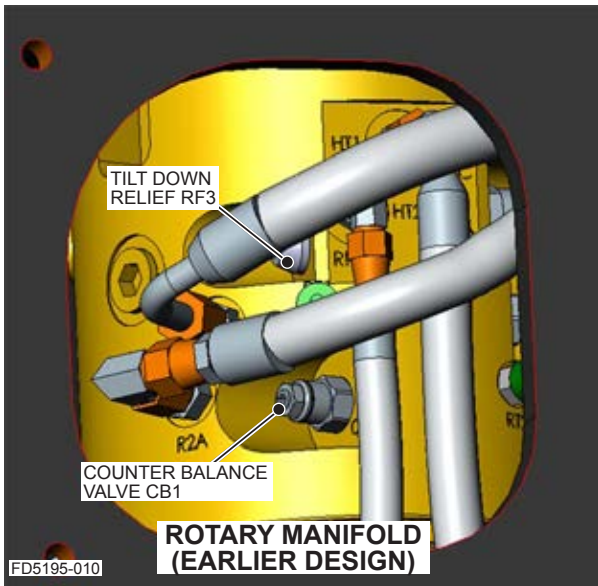
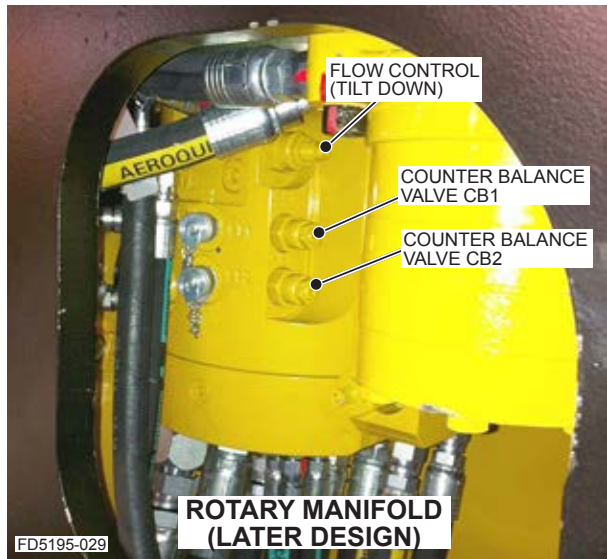
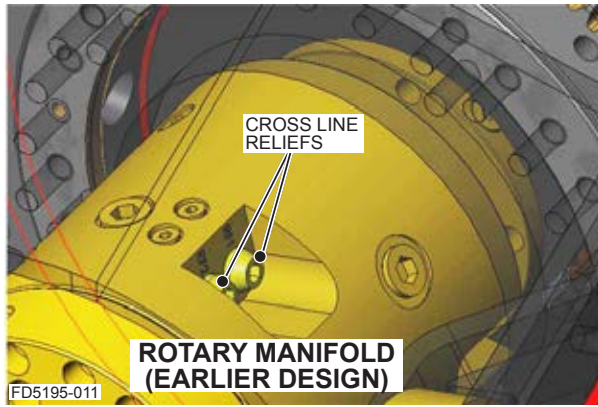



11. Press and hold GRAPPLE open.
12. Use the IQAN MD3 to adjust GRAPPLE open Min setting until the function just starts to activate. DO NOT press OK.

While adjusting the Min, the output is limited to the Min value.

⊖ Adjust– Hydraulics – for Grapple Open use TELE/GRAPPLE/LVL L (LX)[-open] (XA2-A1 COUT D).

Refer to SECTION 6 of carrier manual for more computer information.

13. Adjust GRAPPLE OPEN pressure relief on the main valve to meet **Grapple open port relief (cracking pressure)** specification\*, read at 'P'.
14. Adjust GRAPPLE section LS relief (feed reducer) until the reading at 'P' meets **Grapple open/close pressure setting** specification\*.

\* Refer to PRESSURE AND SPEED SETTINGS–FD5195 chart in THIS SECTION.

## CLAMP ARM (GRAPPLE) SPEED SETUP (FD5195 ON S855C)

1. Park machine on firm level ground. Set head firmly on ground with tilt up locks installed. Stick boom fully extended to prevent boom creep. Hydraulic oil must be at **operating temperature**.
2. Start machine and bring to full throttle.
3. Turn pilot on.
4. Adjust GRAPPLE CLOSE flow control on the main valve, measuring grapple close speed after each adjustment, until grapple close time meets speed **Grapple Close** speed specification\*.

Start with a slower speed and increase until correct speed achieved.

5. Adjust GRAPPLE OPEN flow control on the main valve, measuring grapple close speed after each adjustment, until grapple open time meets speed **Grapple Open** speed specification\*.

Start with a slower speed and increase until correct speed achieved.

\* Refer to PRESSURE AND SPEED SETTINGS–FD5195 chart in THIS SECTION.

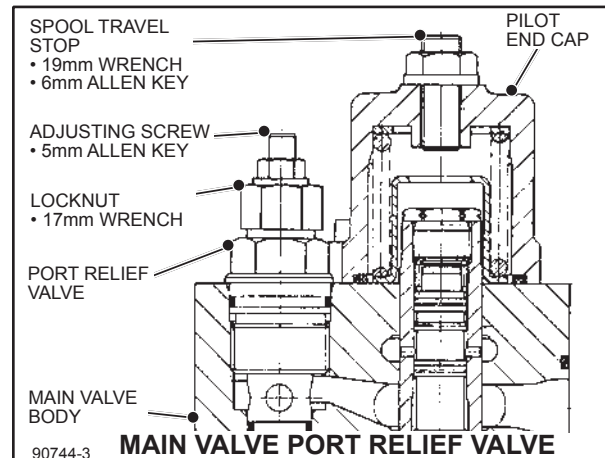
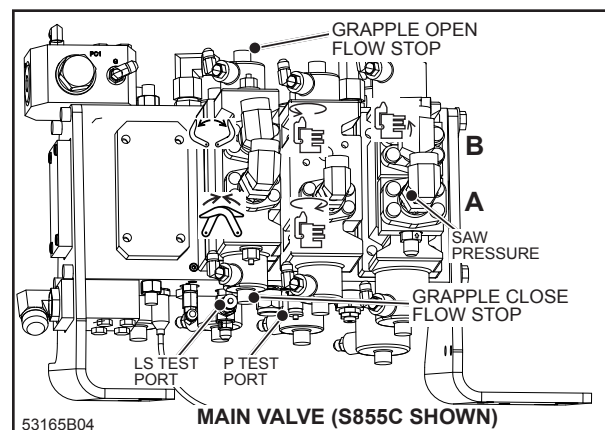

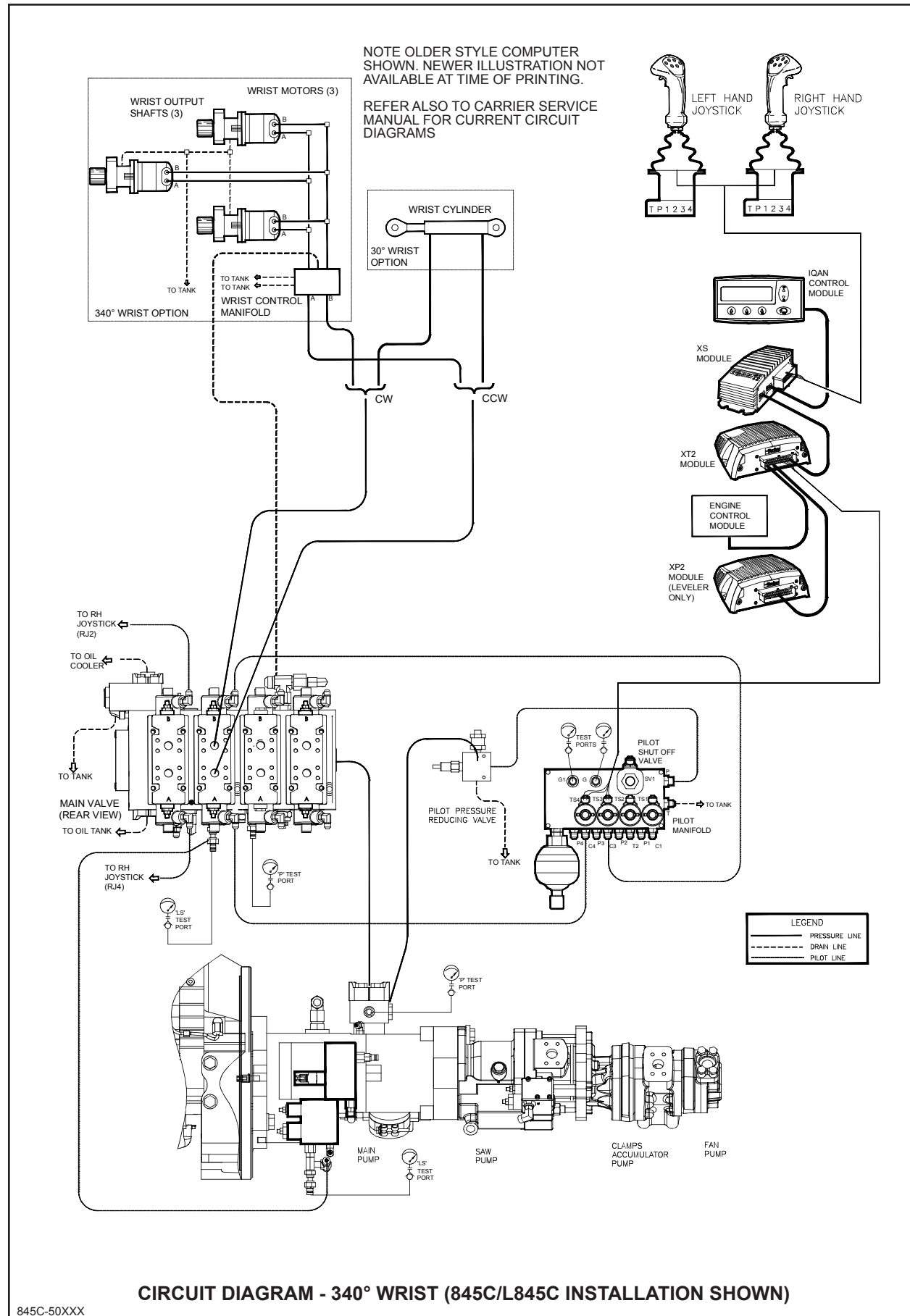

### SET COUNTERBALANCE VALVE PRESSURE

Prior to adjusting wrist manifold counterbalance valves carrier settings must be set as outlined above. Note that adjustment specifications\* are different for standard torque wrists and high torque wrists for proper adjustment and wrist operation.

Note that there are two types of counterbalance valves in use, either Sun or Eaton. Adjustment is different for each type of adjusting valve. Verify which valve is being used prior to adjusting. Both valves must be the same type for proper operation.

21. Park machine on firm level ground, lower felling head to the ground, engage swing brake and stop engine. Block tracks.
22. Ensure that the hydraulic oil is at operating temperature.
23. Remove right motor cover and connect two 0-5000 psi (0-345 bar) pressure gauges to UPPER and LOWER test ports on distribution manifold.

Note that the head will be moved during this procedure so gauges must be mounted so they can be read safely by an assistant.

24. Start the engine and set engine speed to LOW idle.

NOTE: Increase engine speed slightly if pressure reading on pressure gauge is erratic.

Do NOT over rotate wrist at low idle with head in a vertical position. Wrist damage and loss of control may occur at low idle with the head in a vertical position. ALWAYS position head tilted forward so that the wrist is in the horizontal plane when engine speed is set to LOW idle.

25. Close cab door and press PILOT RESET switch to activate pilot system.
26. Adjust counterbalance valve for clockwise wrist rotation.

With the aid of an assistant raise the boom and position head tilted forward so that the wrist is in the horizontal plane. Rotate the felling head WRIST fully clockwise. While holding the joystick wrist trigger switch depressed.

Check the gauge reading at GA and adjust counterbalance valve adjusting screw CBA.

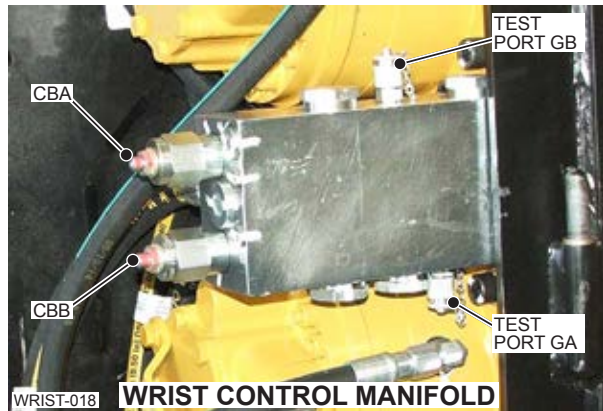

#### FOR SUN ADJUSTING VALVE

Adjust clockwise so it just starts to crack open and relieve (pressure on gauge starts to drop), then turn screw counter clockwise until pressure on gauge is stable (stops relieving) then turn a further 1/8 turn counter clockwise.

#### FOR EATON ADJUSTING VALVE

Adjust counter clockwise so it just starts to crack open and relieve (pressure on gauge starts to drop), then turn screw clockwise until pressure on gauge is stable (stops relieving) then turn a further 1/8 turn clockwise.

## Tigercat Bar Saw Felling Head

10. Remove shoulder ring, retaining ring and shims from output shaft. (Note some earlier machines did not have a shoulder ring factory installed.)
11. Rest housing on blocks in upright position, pinion down and press out shaft complete with seal collar and inner race of lower bearing.
12. Remove old oil seal (teflon ring and 'O' ring) from groove of housing and discard. NEVER re-use any part of old seal.
13. Remove wiper from collar and discard.  
**If only replacing the seal go to step 21.**
14. Remove seal collar and lower bearing inner race from shaft.
15. Press out both upper and lower bearings from housing.
16. Thoroughly clean housing and shaft.
17. Lightly oil bore of housing and press a new *upper* bearing into the housing. Use special tool Tigercat PART No. 19047A.
18. Lightly oil bore of housing and press a new *lower* bearing into the housing. Use special tool Tigercat PART No. 19047A.
19. Heat sealing collar and lower bearing inner race in a bearing oven to 250°F (120°C), do not place on floor of oven. (Maximum 1.5 hours)
20. Install seal collar and lower bearing inner race onto shaft. Press both on simultaneously by supporting inner race (using a spacer - Tigercat PART No. 19048A) and pressing down on pinion end of shaft.
21. Clean seal groove in housing and insert new 'O' ring part of seal into groove. Keep inside of housing clean and free from contaminants.
22. Insert new teflon part of seal into groove in housing on top of 'O' ring. Collapse ring as shown in fig. 127, **taking care not to crease** the seal ring. Place into groove as shown. Coat the inside surface of the seal



## Lubrication , Maintenance and Service

- with hydraulic oil and use seal seating tool (Tigercat PART No. 19057A) or fingers to smooth out the inside diameter of the seal ring after installation.
23. Check wiper groove in seal collar to ensure it is clean and dry. Insert a new wiper into the groove with lip facing out, see fig.126.
  24. Position housing with lower bearing facing up. Support inner race of upper bearing with special tool Tigercat PART No. 19049A.
  25. Oil teflon seal ring surface, wiper and bearings and install output shaft into housing, lightly tap into position so that sealing collar slips into the teflon seal ring and the wiper slips into the housing. (Note: To prevent extrusion of the wiper, carefully push it in around the edge of the collar once it starts to engage the housing.)  
  
Use only enough pressure to seat the bearings. Check to ensure the shaft is installed straight, collar clears housing and wiper is evenly positioned.
  26. Install shoulder ring and retaining ring on shaft (square edge of shoulder ring next to snap ring) and check shaft end play, use feeler gauge between upper bearing inner race and shoulder ring, maximum allowable end play is 0.006 in - 0.010 in (0.15 mm - 0.25 mm). Add or remove shims between shoulder ring and inner race to achieve correct end play. Using a soft-faced hammer gently tap the end of the shaft until the shoulder ring is snug to the snap ring.
  27. Turn housing over. Check seal collar for run-out. Place the base of a dial indicator on the housing and zero the dial on the seal collar, rotate the shaft one revolution (use tool Tigercat PART No. 19122A), maximum allowable run-out is 0.002 in (.05 mm). Repeat in different locations of the seal collar.

CLICK HERE TO **DOWNLOAD** THE COMPLETE MANUAL

- Thank you very much for reading the preview of the manual.
- You can download the complete manual from: [www.heydownloads.com](http://www.heydownloads.com) by clicking the link below



- Please note: If there is no response to CLICKING the link, please download this PDF first and then click on it.

CLICK HERE TO **DOWNLOAD** THE COMPLETE MANUAL