

Genie

V-2470 & V-2470RT

VERTICAL LIFTS

SERVICE AND PARTS MANUAL

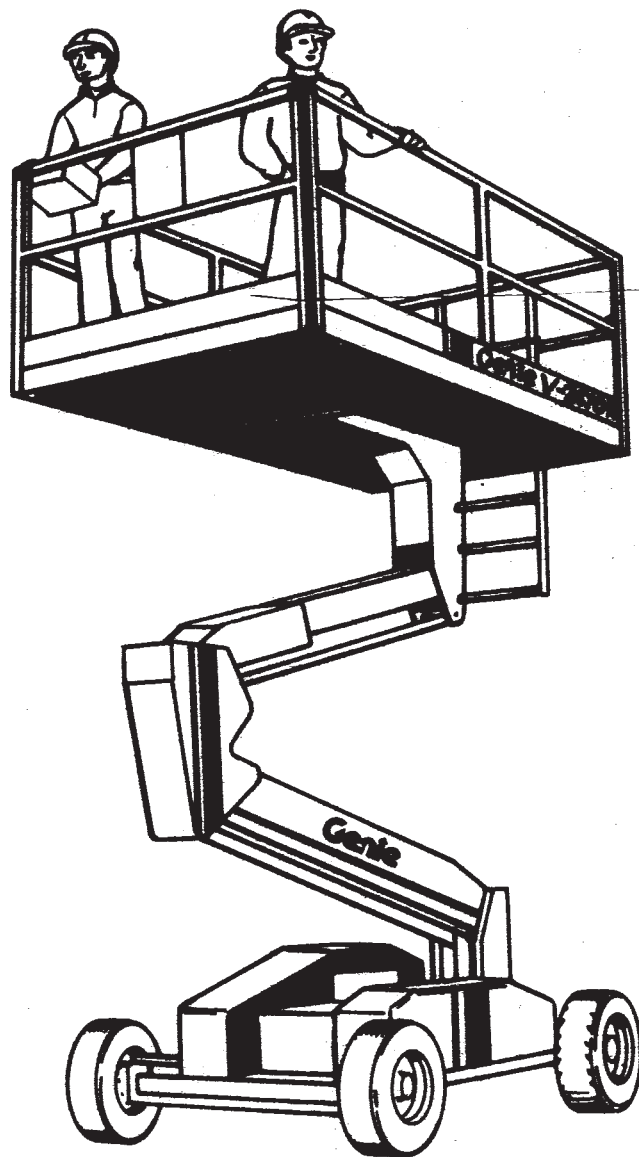
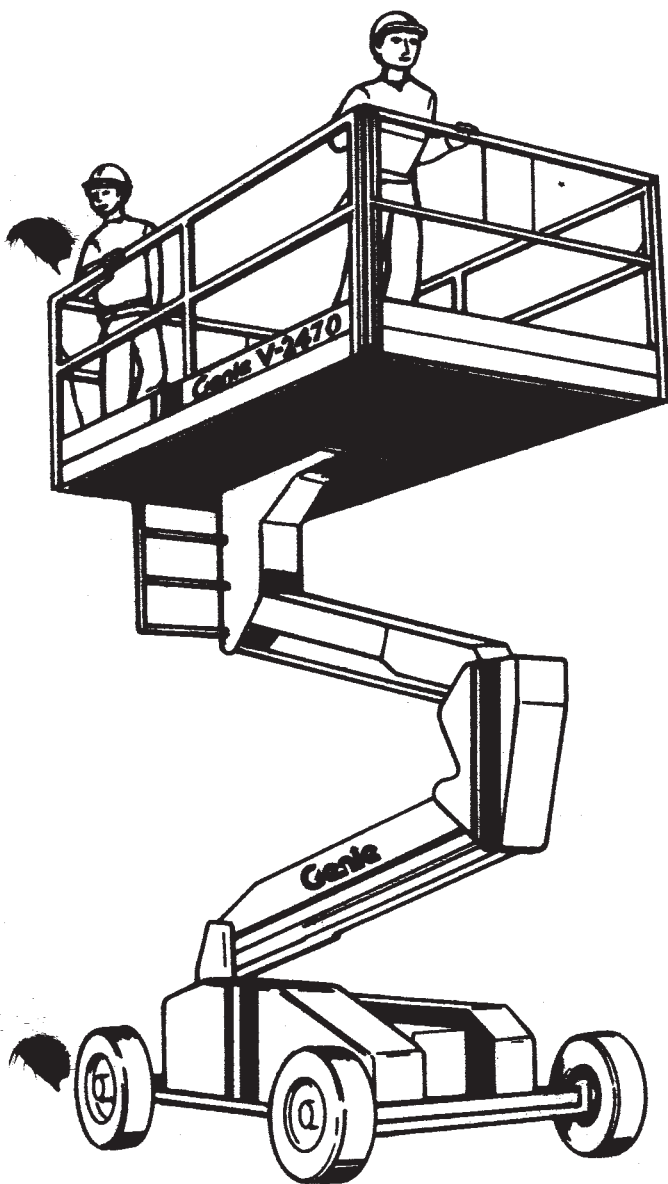

CLICK HERE TO **DOWNLOAD** THE COMPLETE MANUAL

- Thank you very much for reading the preview of the manual.
- You can download the complete manual from: www.heydownloads.com by clicking the link below



- Please note: If there is no response to CLICKING the link, please download this PDF first and then click on it.

CLICK HERE TO **DOWNLOAD** THE COMPLETE MANUAL

2.1 MANDATORY PRECAUTIONS

Your safety is Genie's utmost concern. Please make certain each person operating or servicing the machine reads and understands all of the following precautions. Please do not hesitate to call our Customer Service department toll free at 800-426-8089 if you have any questions regarding the proper use or maintenance of this equipment.

Before using a Genie Vertical Lift, perform the preoperation inspection detailed in section 3.2.

IMPORTANT: DO NOT USE DAMAGED EQUIPMENT.

WARNING: FAILURE TO COMPLY WITH THE SAFETY REGULATIONS LISTED IN THIS SECTION MAY RESULT IN SERIOUS PERSONAL INJURY AND PROPERTY DAMAGE.

- o DO NOT change operating or safety systems.
- o DO NOT operate any machine on which DANGER, WARNING, CAUTION or instruction placards or decals are missing or illegible.
- o Only those personnel who have demonstrated that they understand safe and proper operation of the machine shall be authorized to operate the machine.
- o Never use the Genie Vertical Lift for any purpose other than positioning personnel, their tools and equipment.
- o Always familiarize yourself with the location and operation of ground control station.
- o Always close gate across entrance after mounting platform.
- o Always use safety belts and lanyards when occupying the platform. The belt should be positioned at the occupant's waist with the lanyard attached in the rear. *

GENIE VERTICAL LIFT (Models V-1832, V-1854 & V-2470) OPERATING INSTRUCTIONS



Part No. 20955.

CAUTION

Understanding these Safety Rules and Operating Instructions is critical to the safe operation of Genie Vertical Lifts. Please study this brochure carefully, and make sure that all personnel using the Genie Vertical Lift read and understand it completely before using this equipment.

GENIE VERTICAL LIFT V-2470RT

OPERATING INSTRUCTIONS

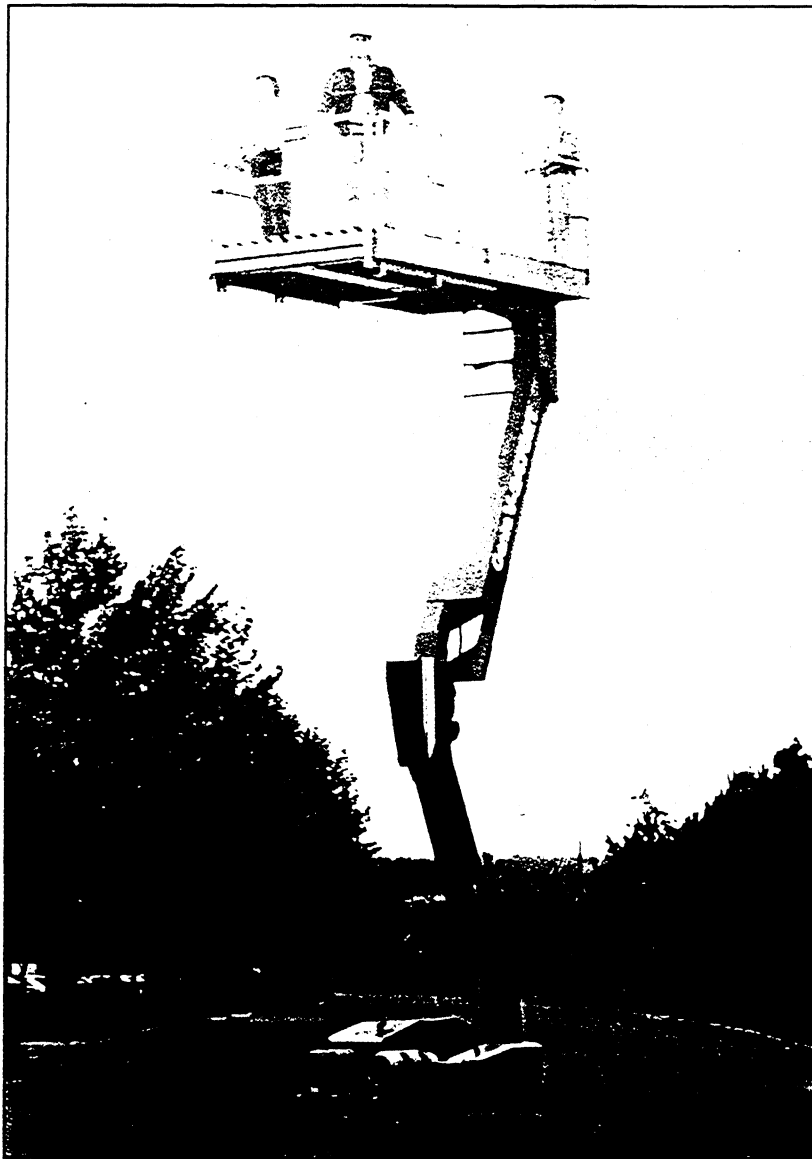

Part No. 20956

CAUTION

Understanding these Safety Rules and Operating Instructions is critical to the safe operation of Genie Vertical Lifts. Please study this brochure carefully, and make sure that all personnel using the Genie Vertical Lift read and understand it completely before using this equipment.

Genie Industries

MAINTENANCE & ROUTINE SERVICE

DAILY SERVICE CHECK

- Thoroughly inspect the entire machine for physical damage and wear. Repair any defects before operating the machine.
- Thoroughly inspect all hoses and hydraulic connections. Repair any defects.
- Check all electrical wires and cables for abrasions and proper connections.
- Check hydraulic fluid level (Photo 13, detail A).
- Check engine oil level (Photo 13, detail B). +
- Maintain tire pressure of 35 psi (Photo 14).
- Check lug nuts for tightness. Torque to 140-150 ft.-lbs (Photo 14).

FIRST TWO WEEKS (25 HOURS)

- Change engine oil filter (Photo 13, detail B). +
- Change engine crankcase oil (Photo 13, detail B). +
- Service engine air filter every 25 hours (Photo 13, detail B). *+

FIRST MONTH (OR FIRST 50 HOURS)

- Change oil in drive gear boxes. Use EP-90 weight (Photo 14).
- Change hydraulic oil filters (Photo 13, detail C). *
- Check battery electrolyte level and clean battery tops and posts (Photo 13, detail D).
- Change engine oil filter every 50 hours (Photo 13, detail B). *+
- Change engine crankcase oil every 50 hours (Photo 13, detail B). *+

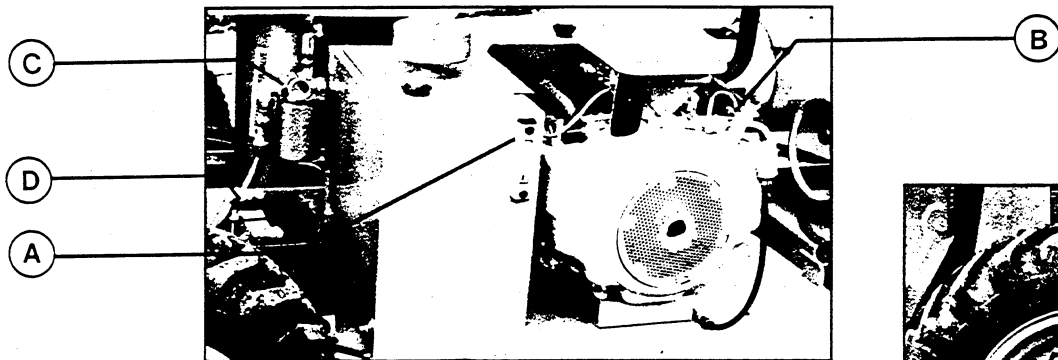

13 — Motor, Hydraulic Reservoir and Battery

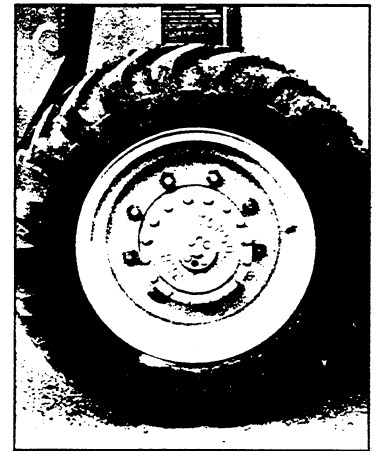

14 — Wheel and Drive Installation

EVERY SIX MONTHS (OR EVERY 250 HOURS)

- Inspect elevate assembly pivot points for signs of wear.
- Inspect steering and front end assembly for signs of wear.
- Check engine RPM. Set at 3100 to 3200 RPM (Photo 13, detail B).
- Change engine air filter (Photo 13, detail B). *+
- Clean engine crankcase breather valve (Photo 13, detail B). *+
- Check engine fuel filter (Photo 13, detail B). *+
- Change oil in drive gear boxes. Use EP-90 weight (Photo 14).
- Change hydraulic oil filters (Photo 13, detail C). *
- Service hydraulic reservoir, replace suction screens and filler breather (Photo 13, detail A). *

EVERY TWO YEARS (OR EVERY 1000 HOURS)

- Repack front axle bearings. Use Texaco Marfax or equivalent multipurpose lithium grease.
- Change hydraulic oil. Use Shell Tellus T-46 or equivalent (Photo 13, detail A). *



Refer to the engine manufacturer's operating manual for proper maintenance and service. Extreme dust or temperature conditions will require more frequent servicing.

For complete list of required maintenance service consult Operating and Maintenance Manual.

Electrical System

The electrical system consists of ELEVATE Up/Down, STEER Left/Right, and DRIVE Forward/Reverse. The electrical system uses stored electrical energy to power and control all machine functions. The electrical system can be divided into two categories the control circuit and the power circuit.

The control circuit incorporates the components and circuitry required to turn the machine on and off, or control other electrical devices. Components include the key switch, toggle switches, limit switches, POWER On/Off buttons, low voltage interrupt system (optional), diodes and solenoids. Since the control circuit typically conducts very low current, small diameter wire and multi-wire (19 conductor, 18 AWG) control cables are used, to connect the control circuit components.

The power circuit incorporates the components which convert stored electrical energy into a mechanical force to provide movement. Components include the batteries, electric motors and contacts. Since the power circuit must be able to conduct full operating current, heavy #2 and #4 welding cable is used to connect the power circuit components.

Before any machine functions can be operated, the key switch (located on the ground control station) must be turned to the appropriate PLATFORM or GROUND position and the POWER On/Off buttons must be pulled up. Turning the key switch to either position (PLATFORM or GROUND) and pulling up the POWER buttons completes a 24 volt circuit from the batteries to the printed circuit board located at the ground control station. At the printed circuit board current is used to energize a 24 volt control circuit master relay (located in the ground control station). The 24 volt control circuit master relay energizes a set of 24 volt contacts, which, when closed, completes a circuit supplying 24 volts from the batteries to the selected platform or ground control station actuators.

The ELEVATE Up/Down functions can be operated from either the platform control station or the ground control station by actuating the proper function control toggle switch. When the toggle switch is actuated a circuit is completed from the toggle switch to the 24 volt motor start relay and to the elevate up 24 volt directional control valve solenoid. The ELEVATE Down function is not a powered function and does not supply 24 volts to the motor start relay. When supplied with 24 volts, the motor start relay energizes a set of 24 volt contacts which when closed completes a circuit supplying 24 volts to the hydraulic power

4.2 CONSUMABLE MATERIALS

MATERIAL	DESCRIPTION	LOCATION
Hydraulic Oil	Shell Tellus T-46	Hydraulic Oil Reservoir
Gear Oil	SAE 90 multipurpose Gear Lubricant, API service classification GL-5	Drive Torque Hubs
Thread Adhesive	Loctite Removable Thread Locker 242	Fasteners
Paint	Rudd 91-869, Blue Rudd 91-841, Grey	Painted Surfaces
Wheel Bearing Grease	Texaco Marfax (or equivalent multi-purpose lithium grease)	Front Wheel Hubs
Motor Oil +	API service classification SF or SF/CC Oil.*	Engine Crankcase
Gasoline +	Unleaded regular gasoline preferred.*	Gasoline Tank
Liquid Propane +	Clean, dry liquid propane gas.*	Propane Tank

* Refer to section 6.2, Manufacturers Appendices for specific oil and fuel requirements.

+ V-2470RT only.

Section 4.5 Genie V-2470 Troubleshooting Flow Charts Continued

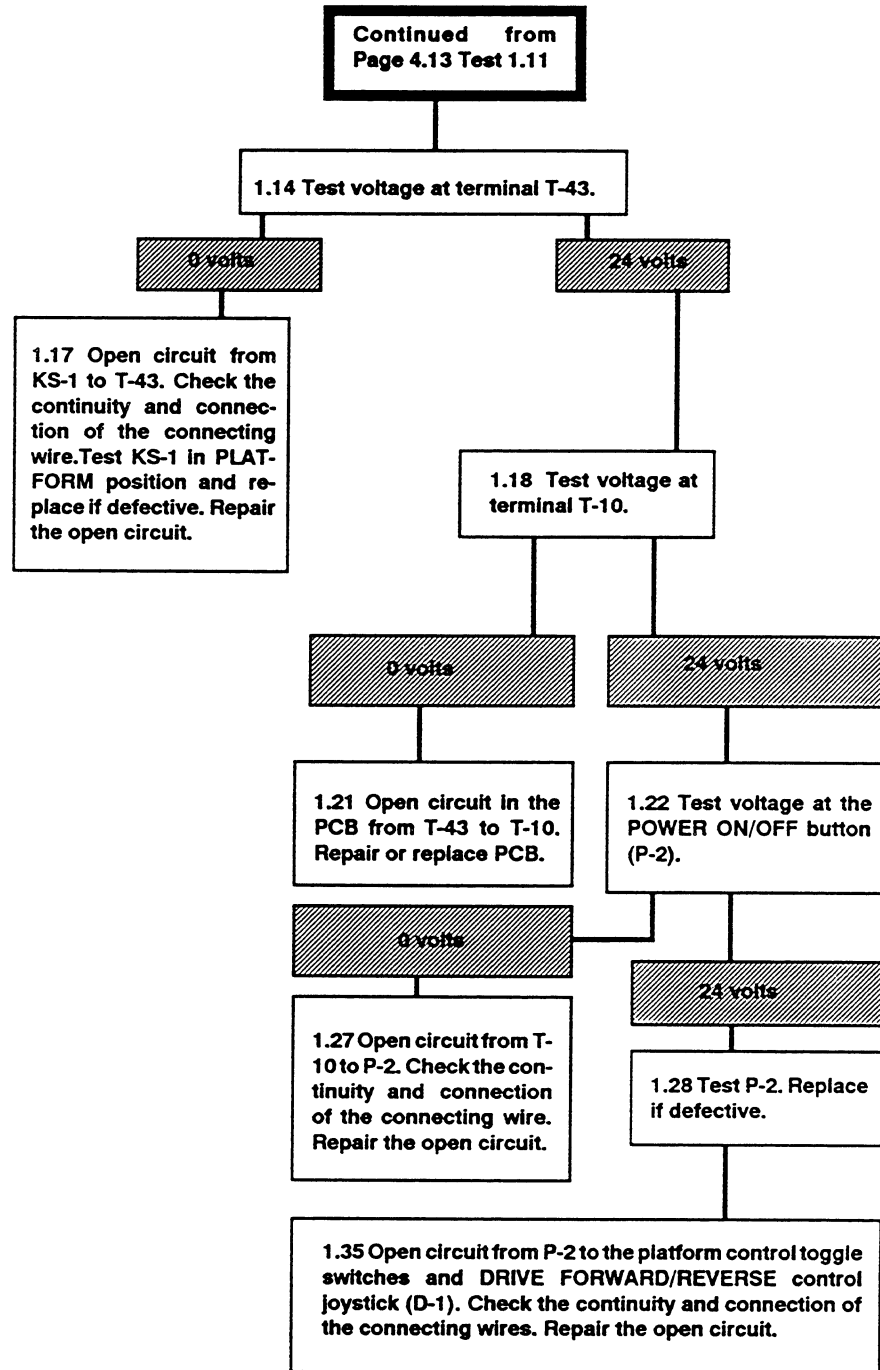

Section 4.5 Genie V-2470 Troubleshooting Flow Charts Continued

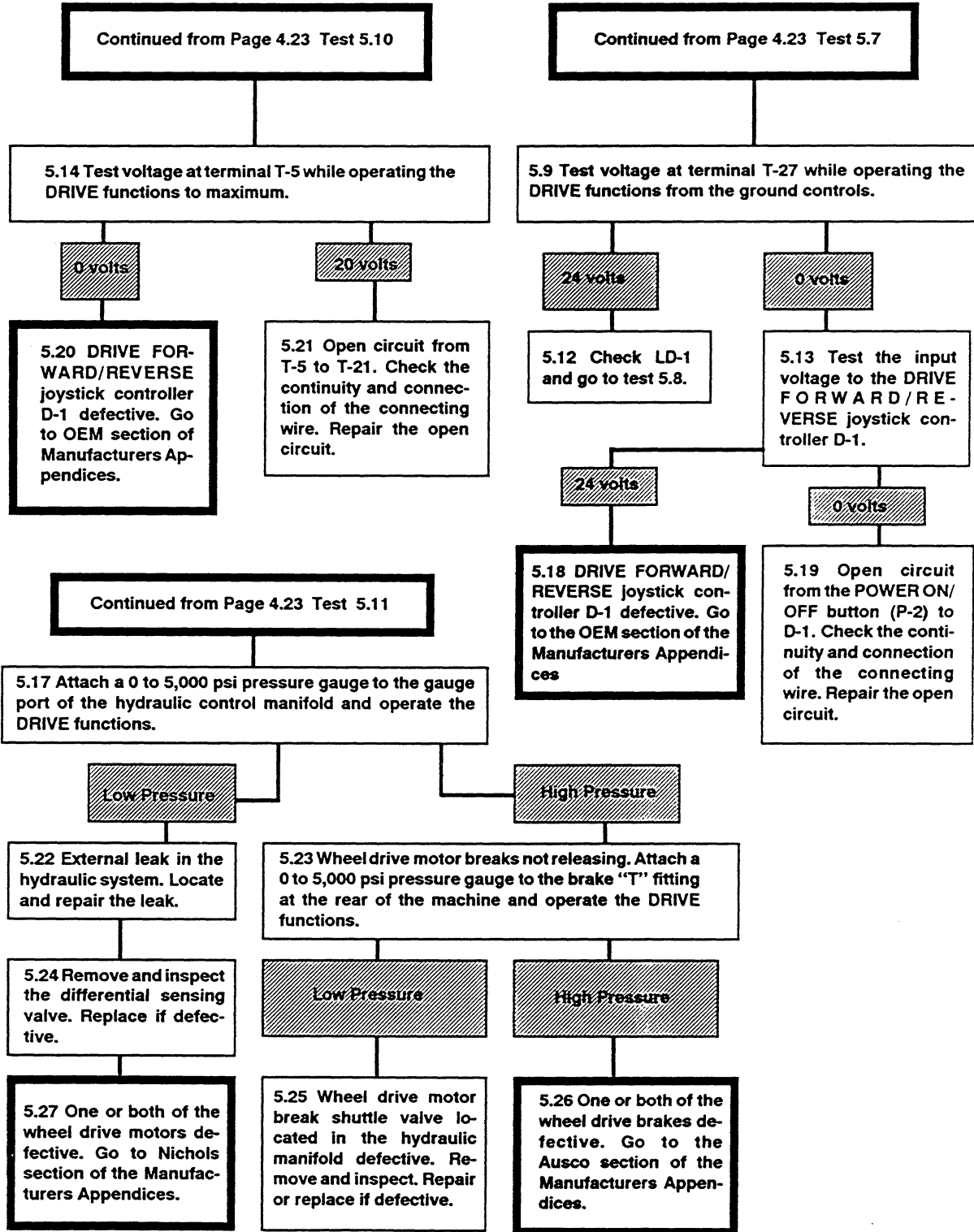

CLICK HERE TO **DOWNLOAD** THE COMPLETE MANUAL

- Thank you very much for reading the preview of the manual.
- You can download the complete manual from: www.heydownloads.com by clicking the link below



- Please note: If there is no response to CLICKING the link, please download this PDF first and then click on it.

CLICK HERE TO **DOWNLOAD** THE COMPLETE MANUAL

Section 4.5 Genie V-2470 Troubleshooting Flow Charts Continued

1. Engine does not crank over.

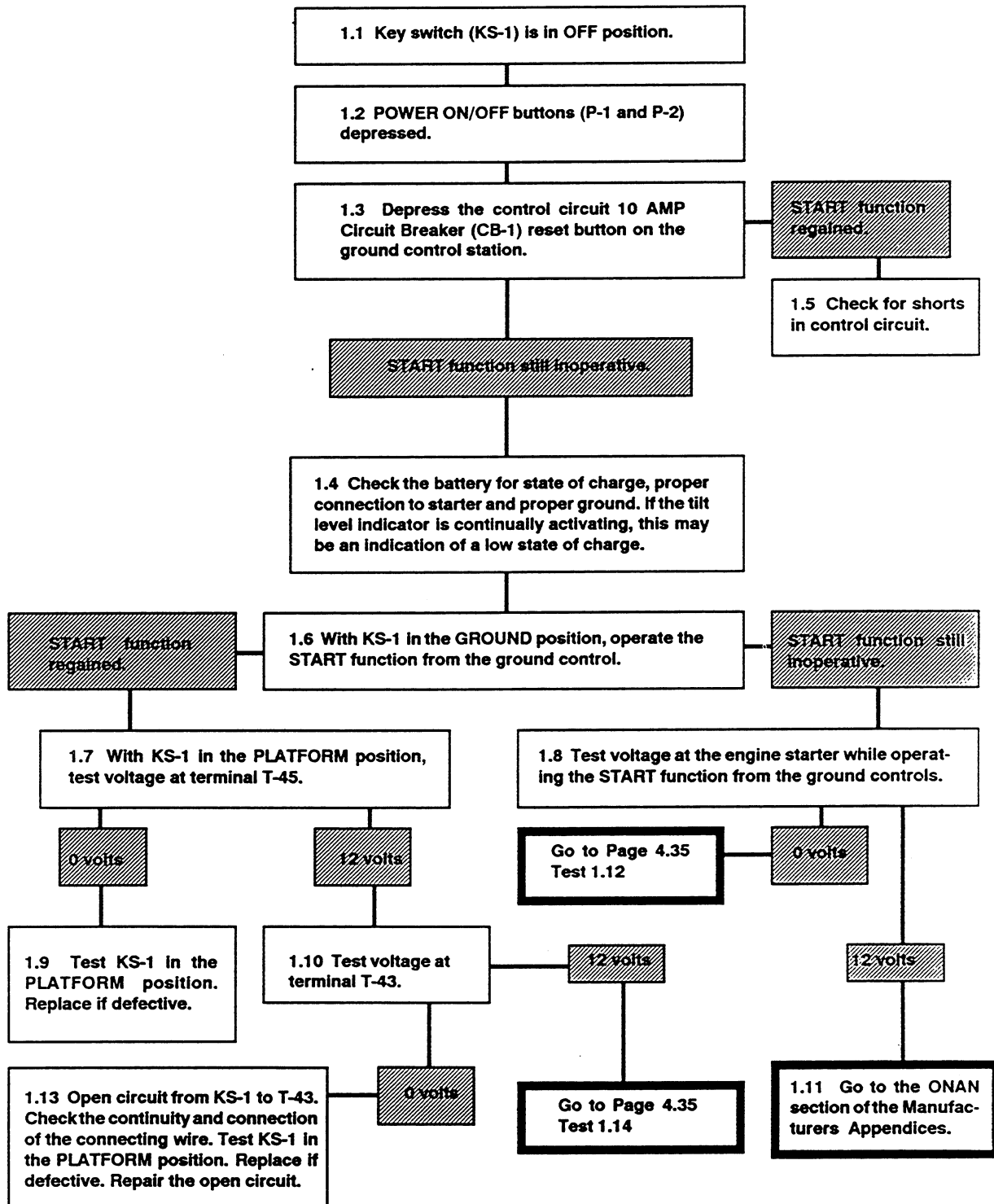

6. ELEVATE Up function inoperative.

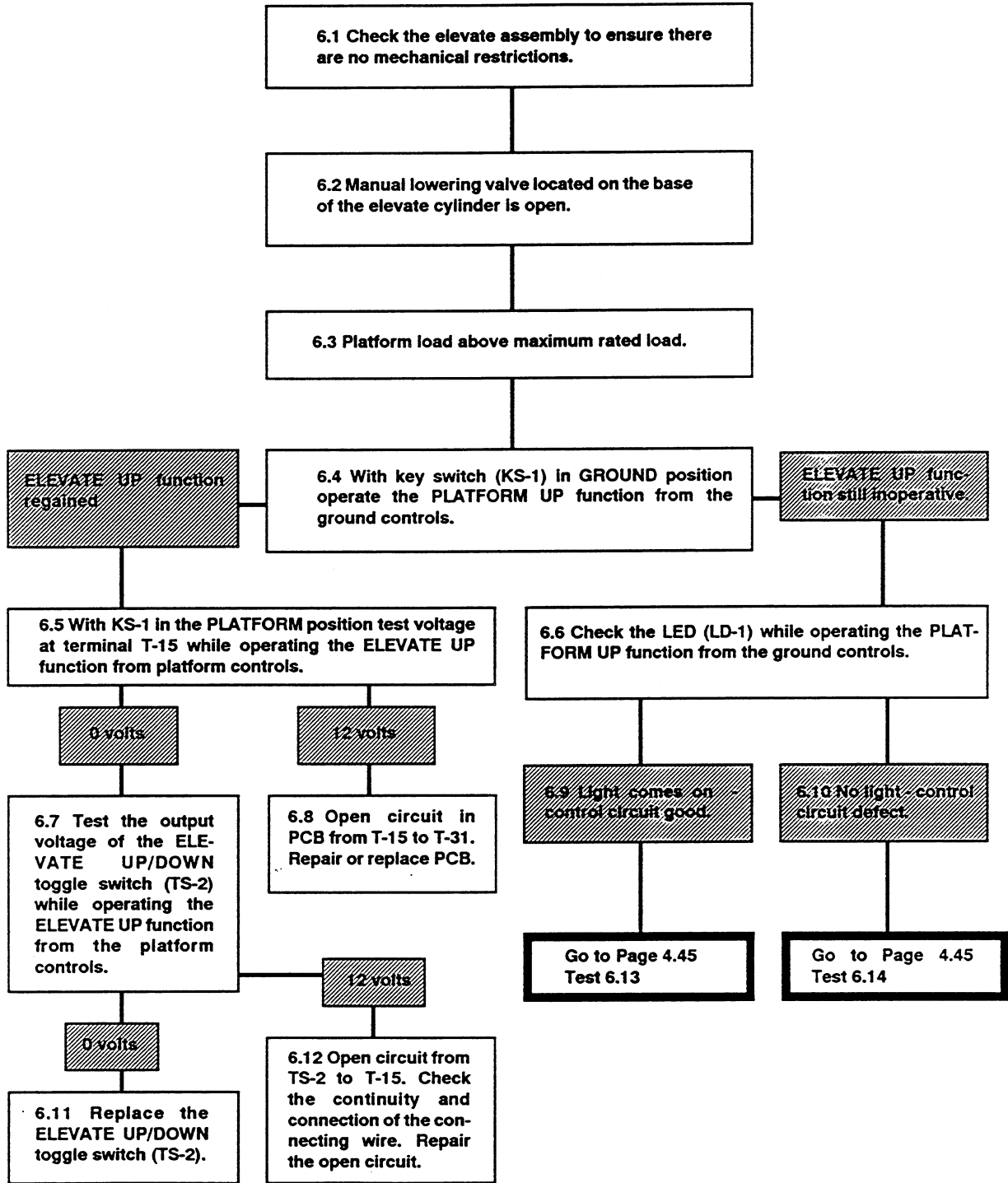

Section 4.5 Genie V-2470 Troubleshooting Flow Charts Continued

12. Machine drives at full speed with platform elevated.

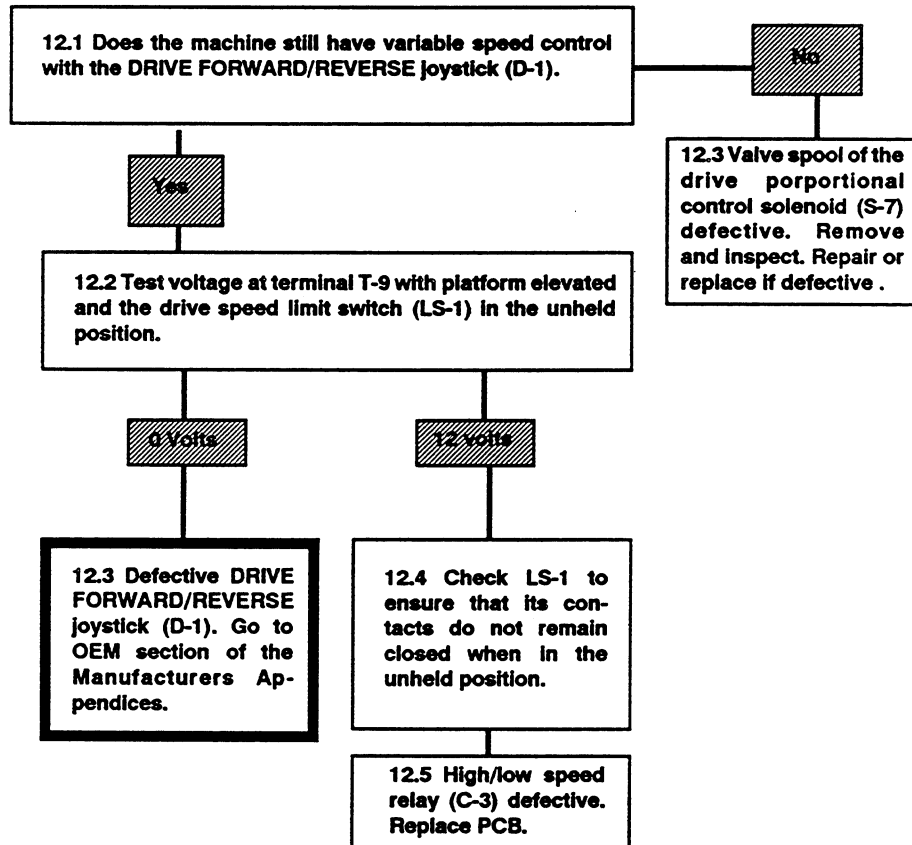

CONTENTS

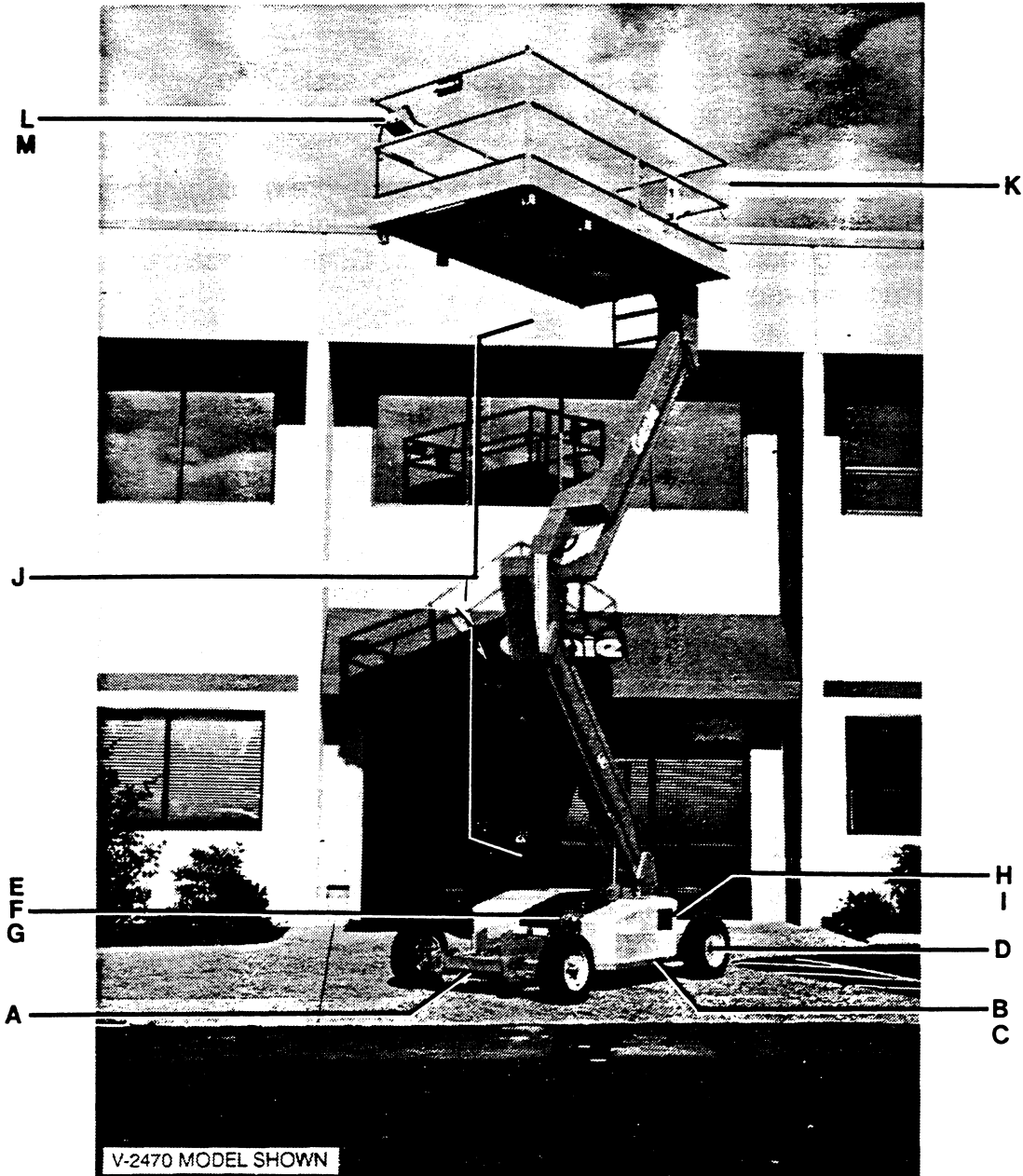

CHASSIS MODULE - V-2470RT**Genie V-2470 & V-2470RT**

Figure	Index Number	Part Number	Description	Qty Per Assy.
C	6.11	19665	HOSE - HYDR RESERVOIR TO HYDR PUMP (BK 10.5 in.)	
C	6.12	20394	HOSE ASSY - DRIVE BRAKE TO BRAKE TEE	1
C	6.13	20438	HOSE ASSY - DRIVE BRAKE TO DRIVE TEE	1
C	7.0	18963	ALARM, 24V DC - INTERMITTENT TONE - NS	1
C	8.0	19270	ALARM, 12V DC - WARBLE TONE - NS	1
C	9.0	19145	HORN, 12V DC - V-2470RT	1
C	10.0	45136	LEVEL SENSOR - NS	1
C	11.0	45462	ALARM, CHIME BELL - NS	1

FIGURE: H GROUND CONTROL BOX - V-2470

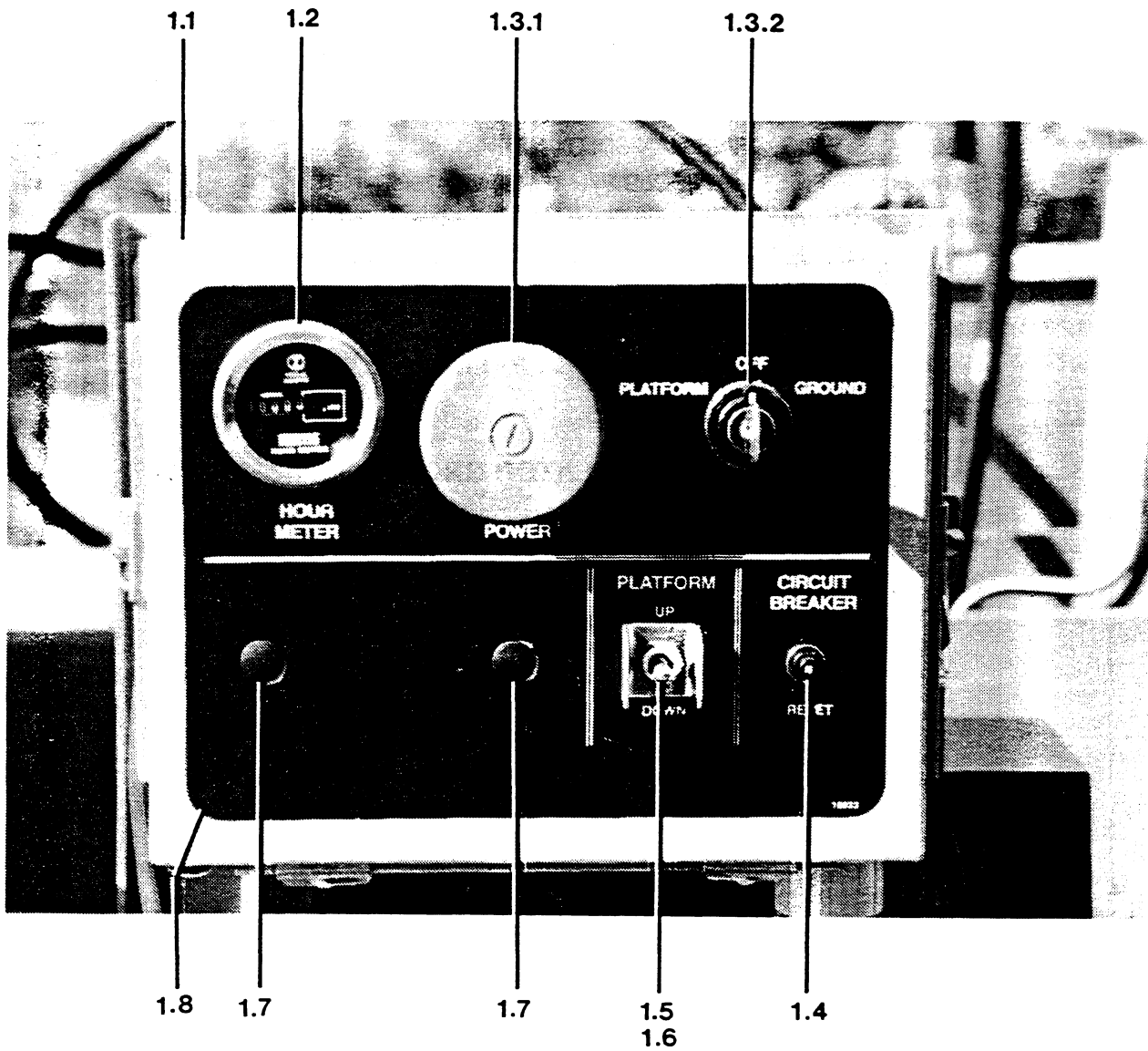

OUTSIDE VIEW

ELEVATE ASSEMBLY

Genie V-2470 & V-2470RT

Figure	Index Number	Part Number	Description	Qty Per Assy.
J	11		COVER GROUP - ELEVATE ASSY	1
J	11.1	45540	PROTECTIVE COIL SLEEVE - (BK ORDER 140 in.)	
J	11.2	18592P	COVER, CONTROL CABLE - LOWER ARM (56 in.) - PNTD	2
J	11.3	18593P	COVER, CABLE - BASE TO MDPVT (12.0 in.) - PNTD	5
J	12		LIMIT SWITCH GROUP	1
J	12.1	28688	SWITCH, LIMIT	1
J	12.2	19344	SWITCH, LIMIT - ARM	1
J	12.3	19491	CONTACT, LIMIT SWITCH - (LIMIT SWITCH P/N 18715)	1
J	13		HYDRAULIC CYLINDER GROUP - V-2470 Series	1
J	13.1	18168	CYLINDER, HYDR - LIFT - V-2470 & V-2470RT	1
J	13.2	19006	TUBE ASSY - LIFT RETURN (CYL P/N 18168)	1
J	13.3	14815	ROLL PIN, .25 X 2.25 in. - (CYL P/N 18168)	1
J	13.4	18151	MANIFOLD, HYDR 24V DC (LIFT CYL P/N 18168) V-2470	1
J	13.5	18686	MANIFOLD, HYDR 12V DC (LIFT CYL P/N 18168)V-2470RT	1
J	13.6	45543	VALVE, CHECK (HYDR MNFLD P/N 18151 & 18686)	1
J	13.7	45544	SOLENOID, 2 WAY 24V DC (MNFLD P/N 18151) - V-2470	1
J	13.8	45651	VALVE, NEEDLE (HYDR MNFLD P/N 18151 & 18686)	1
J	13.9	19060	VALVE, FLOW REGULATOR (MNFLD P/N 18151 & 18686)	1
J	13.10	19995	SOLENOID, 2 WAY 12V DC (MNFLD P/N 18686) V-2470RT	1

FIGURE: N DECALS

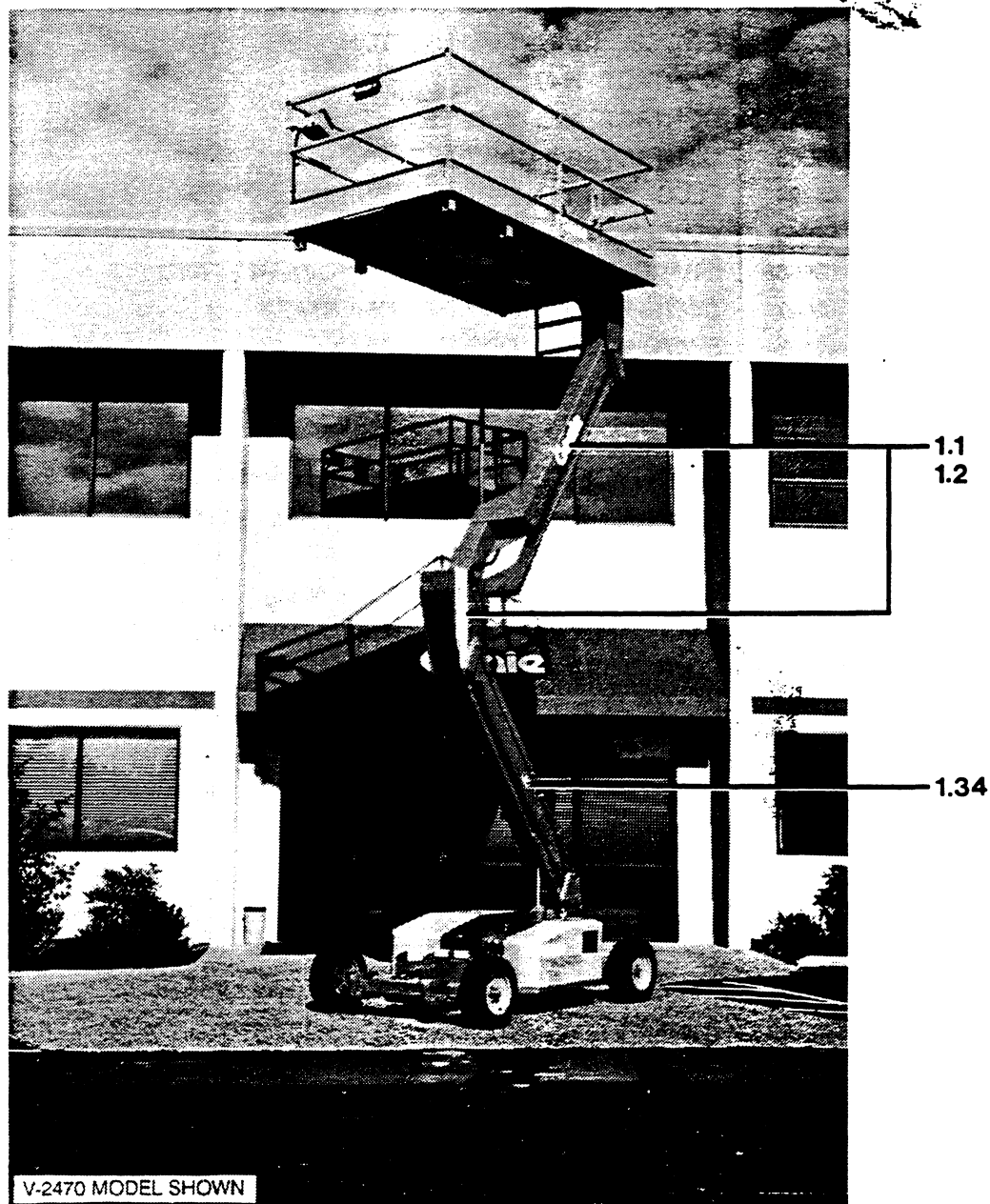

CLICK HERE TO **DOWNLOAD** THE COMPLETE MANUAL

- Thank you very much for reading the preview of the manual.
- You can download the complete manual from: www.heydownloads.com by clicking the link below



- Please note: If there is no response to CLICKING the link, please download this PDF first and then click on it.

CLICK HERE TO **DOWNLOAD** THE COMPLETE MANUAL