

Operation and Maintenance Manual

Rough Terrain Crane

Model **TR-800XXL**

Applicable Serial No. 545457~

▲ CAUTION: Read this manual before operating the crane. Save this manual for future reference.

TADANO LTD.

CLICK HERE TO **DOWNLOAD** THE COMPLETE MANUAL

- Thank you very much for reading the preview of the manual.
- You can download the complete manual from: www.heydownloads.com by clicking the link below



- Please note: If there is no response to CLICKING the link, please download this PDF first and then click on it.

CLICK HERE TO **DOWNLOAD** THE COMPLETE MANUAL

▲ Keep the Engine Clean

Dead leaves, paper dust and oil stains on and around the engine can catch fire. Remove all such debris before commencing operation.

▲ Keep All Footings and Shoes Clean

Oil, water or mud on soles of shoes, steps or decks can cause slip off and fall mishaps or cause accidental release of a control pedal. Always remove oil, mud, water or snow before operation and keep shoes and floor of the operator's cab clean. Do not leave any parts or tools on the operator's cab floor or passageway.

▲ Keep Unauthorized Personnel Away from the Work Area

Unauthorized personnel or vehicles in the work area can result in collision accidents, injury or death. Before operation, make sure there are no unauthorized personnel or obstacles within the work area. If the work area is situated near heavy traffic, post a control person to prevent vehicular accidents. Barricade the work area with appropriate means either colored tape or rope.

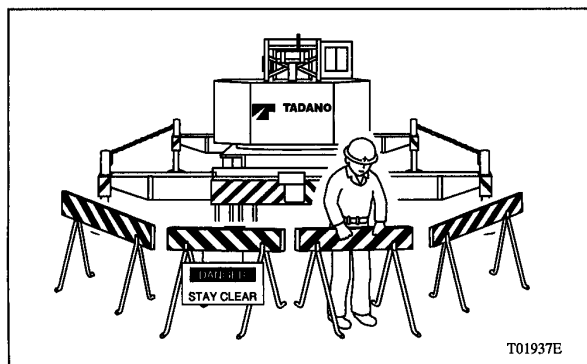

▲ Perform Pre-Operation Inspection

Neglecting routine inspections and maintenance can shorten service life of the machine or even result in an accident.

Before starting operation (and before taking over a shift), perform the pre-operation inspection on the carrier and the upper structure to ensure that the machine is in proper condition and free from any problems.

Should any problem be found, report it to the responsible person, remedy it, and only then start operation.

▲ Never Allow Anyone to Ride on the Machine, Except the Operator

If any persons other than the operator (in the operator's seat) are on the machine, they must be stationed inside the operator's cab.

▲ Safely Climbing onto and Descending from the Machine

Only climb onto or descend from the machine while it is completely at standstill. Use the handrails and steps, always support your hands and feet firmly (three point support); that is, one hand-two feet or two hands-one foot.

Never use the steering wheel or control levers as handrails.

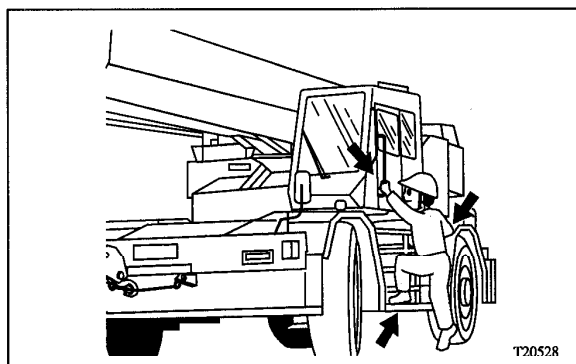

▲ Never Jump Onto or Off the Machine

Do not jump onto or off the machine.

Do not climb onto or descend from the machine with objects in hand.

▲ Avoid Contact with Obstacles

While moving a load, be absolutely sure that the load or any part of the crane does not come into contact with nearby structures or other objects. When working on a site where potential obstacles are present, post a signal person, and only move the load while following instructions.

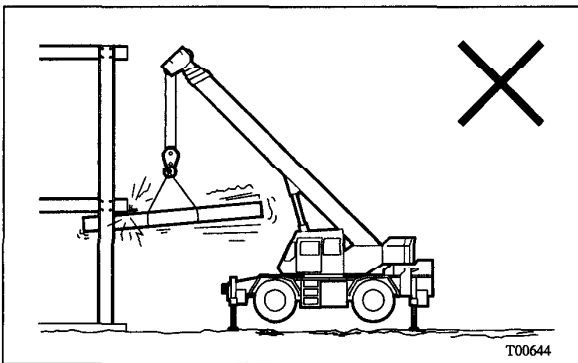

▲ Operate the Crane with Correct Boom Position

When the boom configuration is irregular, for example, the top boom alone is extended for purpose of inspection or maintenance, never attempt to lift a load.

During crane operation, check that all the boom sections are telescoping in the correct sequence. The rated lifting capacity table has been developed based on assumption that the boom sections are telescoped in the correct sequence.

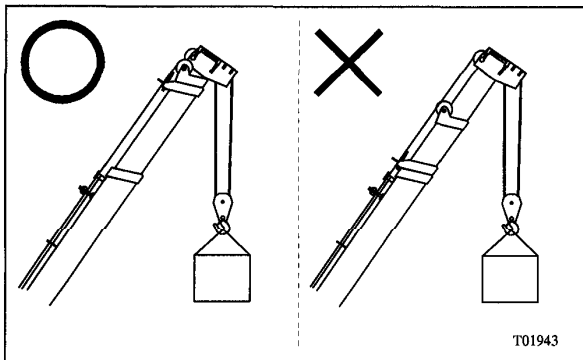

▲ Do Not Extend the Boom Excessively

An excessively extended boom decreases the rated lifting capacity and also can cause overswing of the load or lower working efficiency.

Keep the length of the boom as short as possible during operation.

▲ Be Careful When the Boom Is at Maximum Permissible Angle

When the boom is raised to its maximum permissible angle, there exists minimum horizontal clearance between the boom and the load. A swaying load may hit the boom or jib, and cause damage. Handle the load carefully so that it does not strike the boom or jib.

▲ Avoid Overloading

A load below the rated lifting capacity can still cause overloading of the crane if swaying occurs.

Do not trigger overloading while telescoping out or lowering the boom. These actions increase the working radius and are destabilizing.

▲ When Overloading Occurs

When overloading occurs, never attempt to raise or lower the boom rapidly. This situation is very dangerous as the machine can readily overturn. Immediately set the load on the ground by carefully unwinding the wire rope off the winch drum.

▲ Free Fall Operation (If Machine Is Equipped with Free Fall Device)

Free fall operation with a lifted load can exert a shock on the machine, possibly damaging or overturning the machine. Allow free fall operation only when the hook block has no load.

For safe operation, it is recommended that loads be always lowered under crane power.

Actuate the winch drum brake smoothly during free fall operation to avoid a sudden shock.

▲ If the Engine Stops during Travel

If the crane travels on grades with the engine cut (off), compressed air will not be accumulated in the air tank. Under this condition, frequent use of the brakes will deplete the air tank and result in inoperative brakes. If the engine stops during travel, immediately park and secure the machine in a safe place and attempt to restart the engine. Run the engine until the air supply and air pressure have been restored to proper level.

▲ If the Machine is Stuck in a Tunnel

Immediately flash the hazard lamps. Place a danger sign behind the machine to warn other vehicles of the danger. Afterward, tow the machine to the outside of the tunnel.

Do not attempt to repair the machine inside the tunnel, as this can cause a traffic accident.

▲ Do Not Allow the Machine to Roll in Neutral

When the gearshift lever is put to the neutral position engine braking effectiveness will be lost, and may lead to damage of the transmission system. Do not leave the gearshift lever in the neutral position while travelling.

▲ Cautions for Traveling on Grades

When traveling on a long downhill section of road, do not apply the brake pedal repeatedly or overrev the engine. Repeated use of the foot brake can lead to loss in braking power or even render the brakes inoperative. Overrevving can damage the engine. While on a downhill section, utilize engine braking by gearing down, and actuate exhaust braking. Use the foot brake intermittently to decelerate the machine quickly.

It may be necessary to make special considerations unique to the machine. Travel safely according to the instructions in the "Crane Travel Procedure" section in the manual.

▲ Stop the Machine with Enough Forward Clearance

The boom point projects well ahead of the carrier front bumper. Be careful that the boom point does not exceed the limit line when stopping the machine.

Warning Labels

There are several warning labels affixed to your machine. These labels give important warnings and precautions which must be observed to ensure safety. This section reviews these warnings and precautions, and shows the location of the labels. All the information on the labels is vital for preventing accidents; familiarize yourself thoroughly with it. Make sure that the labels are not soiled. Clean them if words are illegible or pictures are unclear. Replace a damaged or missing label. New labels are available from your nearest authorized TADANO distributor or dealer.

Warning Labels - Location and Contents

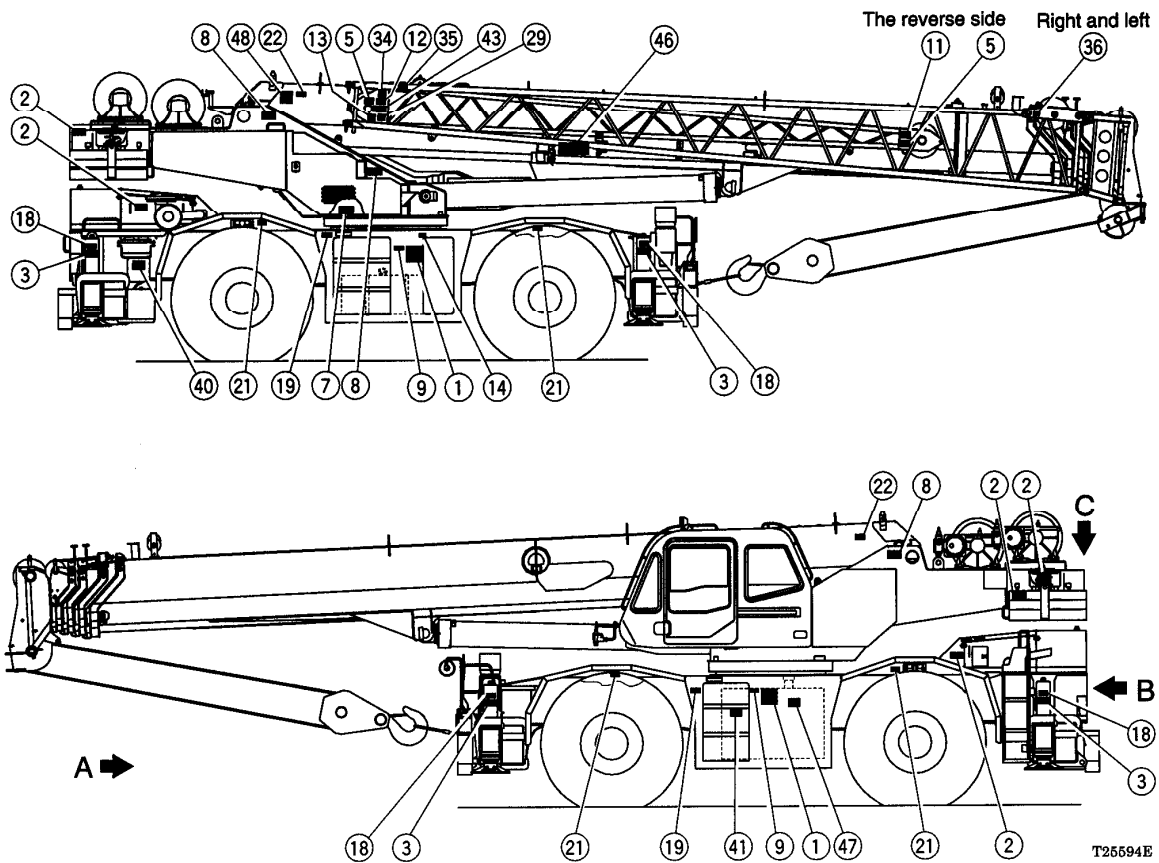

No.46

CAUTION JIB PIN STATUS		
<p style="text-align: center; font-size: small;">BASE+TOP JIB STOWING</p> <p style="font-size: x-small;"> * means pin is inserted. ◁ means pin is extracted. </p>	<p style="text-align: center; font-size: small;">BASE JIB MOUNTING</p> <p style="font-size: x-small;"> * means pin is inserted. ◁ means pin is extracted. </p>	<p style="text-align: center; font-size: small;">BASE+TOP JIB MOUNTING</p> <p style="font-size: x-small;"> * means pin is inserted. ◁ means pin is extracted. </p>

343-954-12600
343-954-12600-0

No.47

CAUTION

After replacing oil or hydraulic pump, do not fail to air-bleed the hydraulic pump. Otherwise the pump may get seized, causing a serious trouble.
 Confirm oil volume while the machine is in traveling style.

TADANO HYDRAULIC OIL LL

370-022-19500
 370-022-19500-1

CAUTION

After replacing oil or hydraulic pump, do not fail to air-bleed the hydraulic pump. Otherwise the pump may get seized, causing a serious trouble.
 Confirm oil volume while the machine is in traveling style.

TADANO HYDRAULIC OIL ISO VG22

370-022-20980
 370-022-20980-0

No.48

CAUTION

STOWING AUXILIARY WINCH ROPE

1. PASS OVER AUXILIARY WINCH ROPE TO ROPE ARRESTERS.
2. ATTACH ROPE SOCKET TO ANCHOR.
3. TAKE IN ROPE UNTIL ROPE IS A LITTLE SLACK.
TAKE CARE NOT TO OVERTENSION ROPE.

343-957-52500
343-957-52500-0

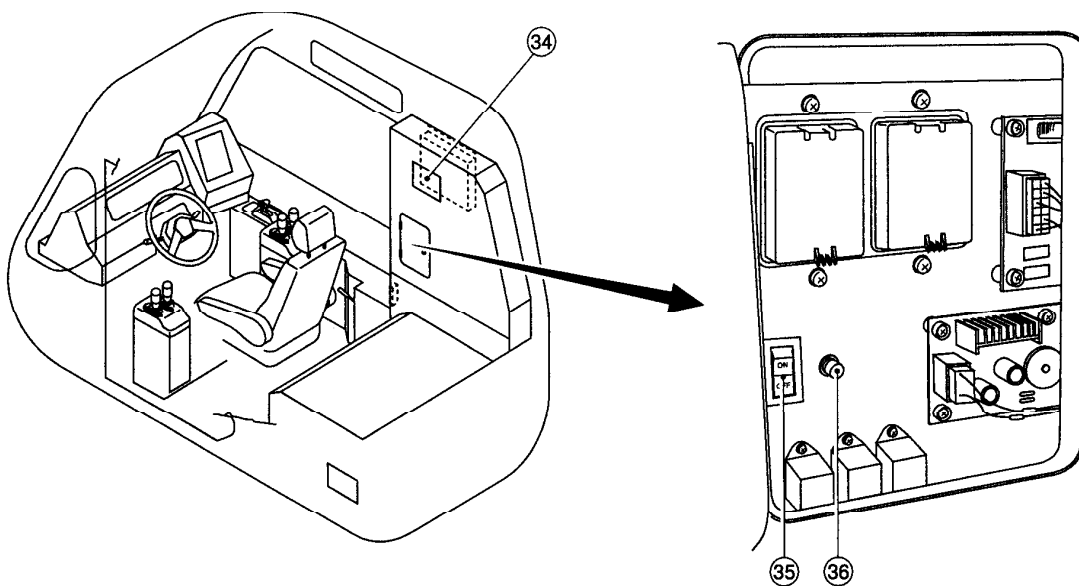

T05733

	See page		See page
1. Air pressure gauge	23	19. Gearshift indicator	26
2. Turn signal indicator lamp	26	20. PTO/travel speed warning lamp	26
3. Speedometer	23	21. Central alarm display	26
4. High beam indicator lamp	26	22. Hazard lamp switch	43
5. Tachometer	23	23. Steering mode select switch	40
6. Turn signal indicator lamp	26	24. Wiper /exhaust brake switch	38, 43
7. Water temperature gauge	23	25. Steering wheel	40
8. Fuel gauge	23	26. Lighting /turn signal switch	43
9. Torque converter oil pressure gauge	23	27. Gearshift lever	35
10. Torque converter oil temperature gauge	23	28. Fuel control knob	30
11. Brake warning lamp	26	29. Starter switch	30
12. Suspension lock indicator lamp	26	30. Accelerator pedal	30
13. Four-wheel drive indicator lamp	26	31. Service brake pedal	38
14. Exhaust brake indicator lamp	26	32. Drive mode select switch	33
15. Low travel speed indicator lamp	26	33. Parking brake switch	38
16. Lock up indicator lamp	26	34. Error number display	57
17. Glow indicator lamp	26	35. Emergency transmission switch	57
18. Rear steering center indicator lamp	26	36. MDT system check switch	57

Parking

◆ Parking the crane for long periods causes the portion of the tires that contact the ground to flatten. This effect may produce vibration until the tires return to their original shape with continued travel. To park for long periods, extend the outriggers and keep the tires off the ground.

1. Depress the brake pedal to stop the vehicle.
2. With the brake pedal held down, shift into Neutral and activate the parking brake.

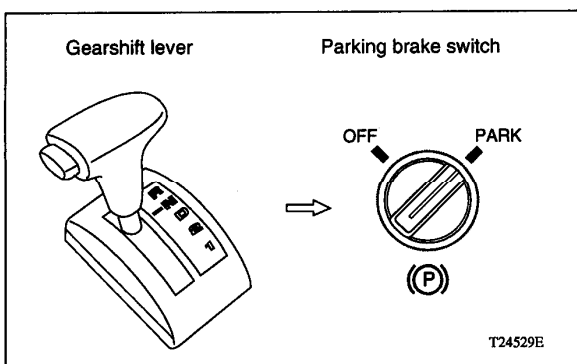

3. Release the brake pedal.
4. Turn off the air conditioner and other equipment inside the cab.
5. If a special traveling mode has been selected, return the steering mode and drive mode to the normal modes (two-wheel steering mode and high-speed two-wheel drive mode).
6. Close all the side windows and door window of the cab.
7. Shut off the engine and remove the starter key.
8. Leave the cab and lock the door.



Central Alarm Display

WARNING

▲ Traveling and crane operation while leaving a warning shown on the central alarm display can lead to a serious accident and damage to the crane. If a warning appears, take safety measures immediately.

Displays a warning sign when some abnormality is detected in one of the crane components.

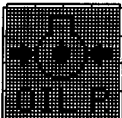
If two or more warning signs are stored for the output, different warning signs will appear in the cycle of 3 seconds.

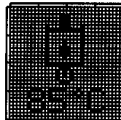
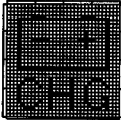
Central alarm display	Machine condition	Safety measures
 Low air pressure warning T20027E	This sign appears and the alarm buzzer sounds when the air pressure is abnormally low. ◆ The alarm buzzer will stop when the parking brake switch is set to "PARK".	Park the crane in a safe location and supply air until the sign goes out. If the sign does not go out, contact your nearest TADANO distributor or dealer.
 Engine oil pressure warning T20028E	This sign appears when the engine oil pressure is abnormally low. ◆ This sign appears when the starter switch is set to "ON" and disappears when the engine starts.	Stop the engine and check the engine oil level if this sign appears while the engine is running. Add the oil if it is short. If the oil level is in the specified range, contact the nearest TADANO distributor or dealer for the cause of the trouble.
 Torque converter oil pressure warning T20029E	This sign appears and the alarm buzzer sounds when the torque converter oil pressure is abnormally low. ◆ The alarm buzzer will stop when the parking brake switch is set to "PARK". ◆ This signs appears when the starter switch is set to "ON" and disappears when the engine starts.	Check the torque converter oil level if this sign appears while the engine is running. Add the oil if it is short. If the oil level is in the specified range, contact the nearest TADANO distributor or dealer for checking the cause of the trouble.
 Hydraulic oil pressure 85°C warning T20815E	This sign appears when the hydraulic oil temperature is 185°F [85°C] or higher.	Stop the crane operation and cool the hydraulic oil temperature.
 Battery charging system abnormality warning T01711E-1	This sign appears when an abnormality of the battery charging system is detected. ◆ This signs appears when the starter switch is set to "ON" and disappears when the engine starts.	If this sign appears while the engine is running, contact the nearest TADANO distributor or dealer.

Brakes

Controls

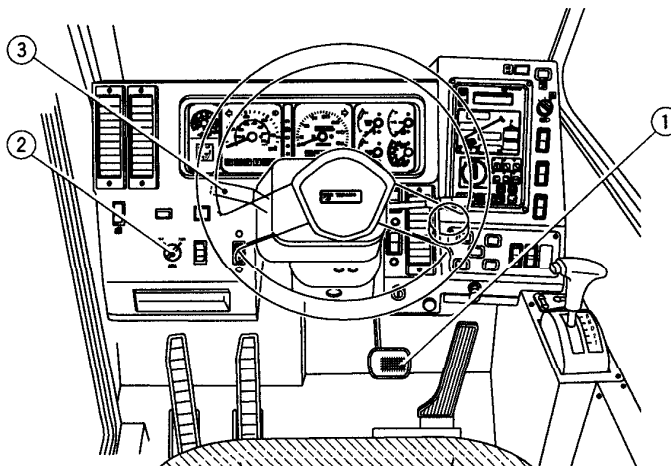

T30508

1. Service brake pedal
2. Parking brake switch
3. Exhaust brake switch

Foot Brake

⚠ WARNING

⚠ Before traveling down a long or steep grade, perform a brake test and make sure that the brake system functions normally.

⚠ Abrupt braking not only damages the tires and brake system, but also causes the vehicle to skid on a slippery road surface. Avoid abrupt braking.

⚠ Excessive use of the service brake pedal can overheat the brake discs and brake pads leading to a decrease in brake performance or "brake fade" which can cause the brake to become inoperable.

When traveling down a long grade, shift down to the proper speed range to activate engine braking and use the exhaust brake as supplement. Slowly pump the service brake pedal to effectively slow down.

⚠ When the brake warning lamp goes on during travel, there may be external leakage of brake fluid or wear of disc brake pad. Stop the carrier immediately and check for fluid leaks and pad wear.

To stop the vehicle temporarily, depress the service brake pedal with the transmission in First, Second, Drive, or Reverse.

Depress the service brake pedal early, slowly pumping it.

Components

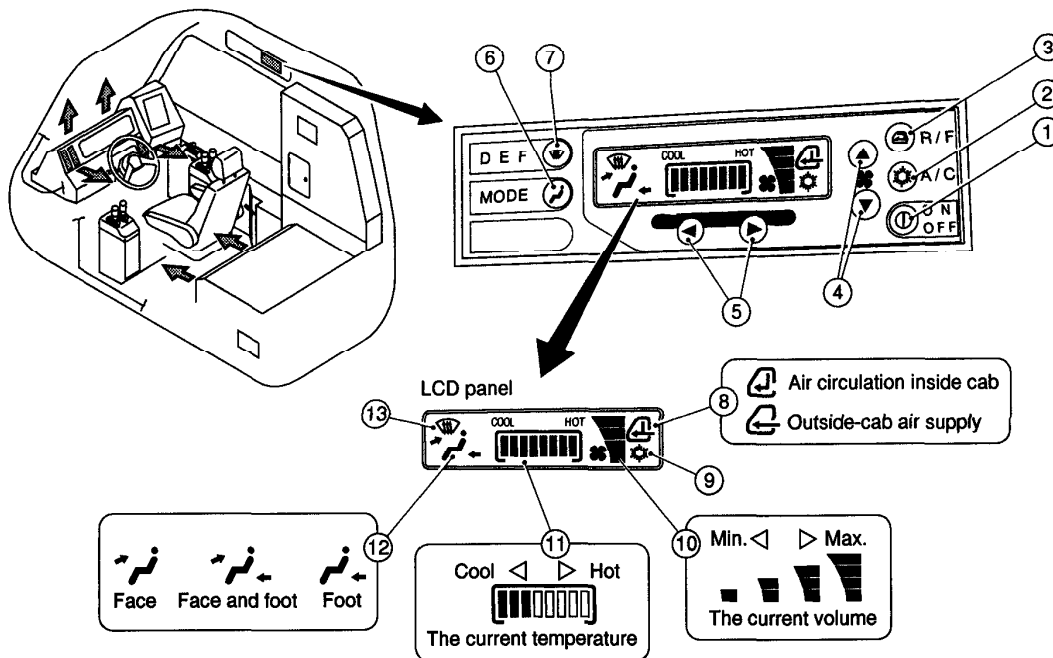

T23161E

Switches

1. Power switch
2. Air conditioner switch
3. Inside/outside air selector switch
4. Air flow switches
5. Temperature control switches
6. Air outlet changeover switch
7. Defroster switch

Signs on the LCD panel

8. Sign of air supply selection
9. Sign of air conditioner operation (Snow-shaped sign)
10. Sign of air flow volume
11. Sign of air temperature
12. Sign of air blowing direction
13. Sign of the defroster switch

- 3.** If shifting gears is possible, move the crane to a service shop.
- ◆ Shift gears not to let the vehicle speed exceed the allowable speed range for the selected gear position.
 - ◆ After you have moved the crane, return the emergency transmission switch to OFF.

Shift position	Speed range	
	Hi	Lo
"1"	0 to 5 MPH (0 to 8 km/h)	0 to 2.2 MPH (0 to 3.5 km/h)
"2"	0 to 12 MPH (0 to 19 km/h)	0 to 4.5 MPH (0 to 7.2 km/h)
"D"	0 to 25 MPH (0 to 40 km/h)	0 to 8.7 MPH (0 to 14.0 km/h)
"R"	0 to 5 MPH (0 to 8 km/h)	0 to 2.2 MPH (0 to 3.5 km/h)

Emergency Gear Shifting Procedure (2)

- 1.** Activate the parking brake. Shift into Neutral and stop the engine.

⚠ WARNING

⚠ A manual locking device for the solenoid valves is provided for moving the crane in case of emergency. Do not touch the locking device except in an emergency.

⚠ Before this operation, take the following safety precautions:

- Stop the engine.
- Apply chocks to the wheels.
- Light the hazard lamps to let the cars behind know the trouble of your carrier.

⚠ If the solenoid valve is manually locked, the vehicle begins to move as soon as the engine starts. Be sure to operate the parking brake and step on the service brake pedal before starting the engine. Be sure to stop the engine and return the lock bolt of the solenoid valve to the original position immediately after the travel of the vehicle.

- 2.** Loosen the lock nut beside the solenoid valve for the transmission. Remove the hexagon bolt. Insert this hexagon bolt into the hole on the manual locking device of the corresponding solenoid valve. Turn it clockwise till it comes to an end. Lock it with the lock nut. The solenoid valve will be the same condition as energized to make the clutch operable.

- ◆ Select solenoid valve to go forward or backward.

Forward	Solenoid valve (1)
Backward	Solenoid valve (2)

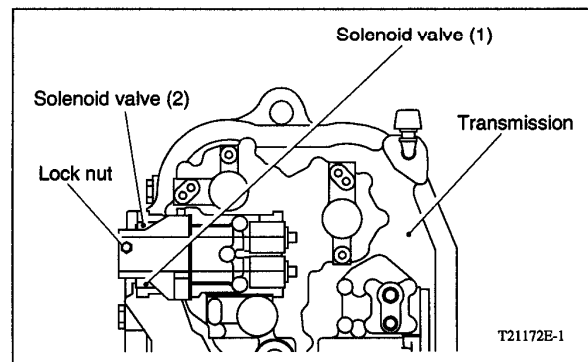

- 3.** Depress the service brake pedal and start the engine.
- 4.** Release the parking brake. Start traveling by letting off the service brake pedal slowly.

Rated Lifting Capacity Table

⚠ WARNING

⚠ The values shown in the rated lifting capacities table are based on ideal conditions where the crane is set level on a firm surface, there is no wind or side load, and the load is not swinging. When operating the crane under these conditions is not possible, reduce the load as necessary according to the actual operating conditions.

Rated lifting capacities tables are set up as shown below with the kind of job and the outrigger extension conditions. For actual values see the rated lifting capacity tables provided in the crane operator's cab.

Kind of job	Outrigger extension
Outriggers extended • Boom lift • Single top lift • Jib lift	Fully extended(23'7-1/2")
	Extended to mid(21'11-3/4")
	Extended to mid(18'1/2")
	Extended to min(9'2-1/4")
Outriggers not extended (On-rubber) • Boom lift • Single top lift	—

NOTES FOR LIFTING CAPACITIES

GENERAL

1. RATED LIFTING CAPACITIES apply only to the machine as originally manufactured and normally equipped by TADANO LTD. Modifications to the machine or use of optional equipment other than that specified can result in a reduction of capacity.
2. Construction equipment can be hazardous if improperly operated or maintained. Operation and maintenance of this machine must be in compliance with information in the operation, safety and maintenance manual supplied with machine. If these manuals are missing, order replacement through the distributor.
3. The operator and other personnel associated with this machine shall fully acquaint themselves with the latest American National Standards Institute (ANSI) safety standards for cranes.

SET UP

1. Rated lifting capacities on the chart are the maximum allowable crane capacities and are based on the machine standing level on firm supporting surface under ideal job conditions. Depending on the nature of the supporting surface, it may be necessary to have structural supports under the outrigger floats or tires to spread the loads to a larger bearing surface.
2. For outrigger operation, outriggers shall be properly extended with tires free of supporting surface before operating crane.

OPERATION

1. Rated lifting capacities have been tested to and meet minimum requirements of SAE J1063-Cantilevered Boom Crane Structures Method of Test.
2. Rated lifting capacities do not exceed 85 % of the tipping load on outriggers fully extended as determined by SAE J765-Crane Stability Test Code. Rated lifting capacities for partially extended outriggers are determined from the formula:
 Rated Lifting Capacities=(Tipping Load - 0.1 x Tip Reaction)/1.25

[Example 4: Outriggers not extended (on-rubber)]

TR-800XXL RATED LIFTING CAPACITIES (IN POUNDS)

Stationary												
Load Radius in Feet	Over Front						360° Rotation					
	Boom Length in Feet						Boom Length in Feet					
	37.7 (11.5m)		64.4 (19.62m)		91 (27.75m)		37.7 (11.5m)		64.4 (19.62m)		91 (27.75m)	
	∠		∠		∠		∠		∠		∠	
10	68	71,200					68	49,500				
12	65	62,200					65	41,700				
15	59	51,600					59	29,400				
20	50	39,400	69	35,300			50	18,000	69	21,300		
25	38	28,000	64	29,400			38	11,600	64	14,700		
30	21	20,300	59	23,600	69	22,100	21	7,600	58	10,600	69	10,600
35			53	18,100	66	19,100			53	7,500	65	7,800
40			47	14,300	62	15,300			47	5,300	62	5,800
45			40	11,200	59	12,400			40	3,600	58	4,200
50			32	9,000	55	10,000			32	2,300	54	3,000
55			21	7,100	50	8,200			21	1,200	50	2,100
60					46	6,600					45	1,300
65					41	5,400						
70					36	4,300						
75					29	3,400						
80					22	2,700						
∆	0°						0°		2 1°		4 5°	
Telescoping conditions(%)												
Telescoping Mode												
2nd boom	0		0		0		0		0		0	
3rd boom	0		33		66		0		33		66	
4th boom	0		33		66		0		33		66	
Top boom	0		33		66		0		33		66	

∠ :Loaded boom angle(°)
 ∆ :Minimum boom angle(°) for indicated length (no load)

LIFTING CAPACITIES AT ZERO DEGREE BOOM ANGLE ON RUBBER STATIONARY.											
Boom Angle	Over Front						360° Rotation				
	Boom Length in Feet						Boom Length in Feet				
	Load Radius in Feet	37.7 (11.5m)	Load Radius in Feet	64.4 (19.62m)	Load Radius in Feet	91 (27.75m)	Load Radius in Feet	37.7 (11.5m)			
0°	31.7	18,600	58.3	6,000	85.0	1,900	31.7	6,600			

NOTE: · The lifting capacity data stored in the LOAD MOMENT INDICATOR (AML-L) is based on the standard number of parts of line listed in the chart.
 · Standard number of parts of line for rubber operation should be according to the following table.

Boom length in feet (meters)	37.7' (11.5m)	37.7' to 91' (11.5m to 27.75m)	Single top Jib
Number of parts of line	6	4	1

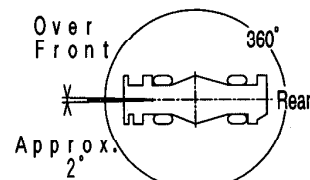

Working Area T25618E

Names and Functions of Load Moment Indicator Main Unit Parts

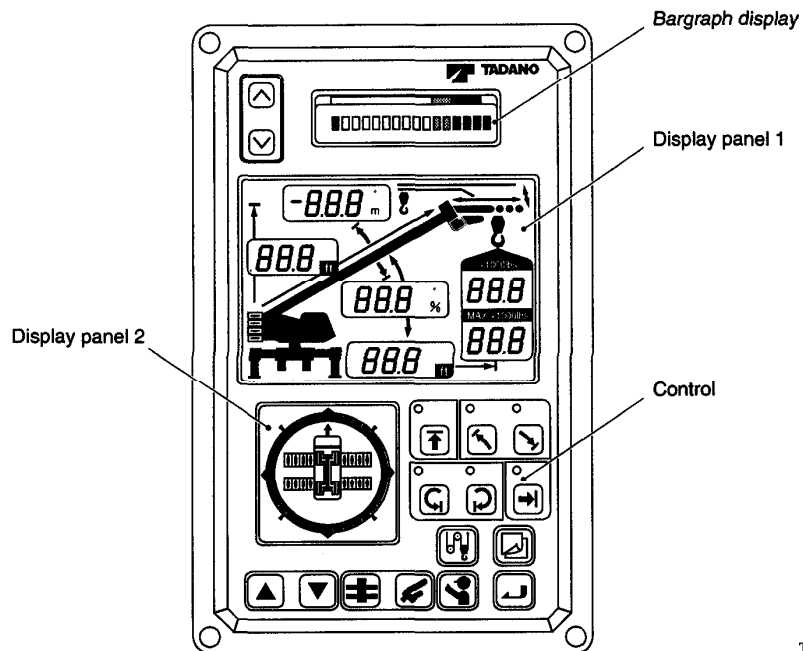

T24565E

CLICK HERE TO **DOWNLOAD** THE COMPLETE MANUAL

- Thank you very much for reading the preview of the manual.
- You can download the complete manual from: www.heydownloads.com by clicking the link below



- Please note: If there is no response to CLICKING the link, please download this PDF first and then click on it.



CLICK HERE TO **DOWNLOAD** THE COMPLETE MANUAL

Selecting Winch Condition

⚠ WARNING

⚠ Select the correct winch according to the actual crane condition; otherwise the load moment indicator will show wrong moment ratio, leading you to damage or overturn the crane.

The lifting capacities vary depending on the operating condition. Register the winch selection using the winch selector switch so that the winch selection indicator lamp is as shown in the table below according to the operating condition.

When main winch is employed	When auxiliary winch is employed
 Not lit	 Lit

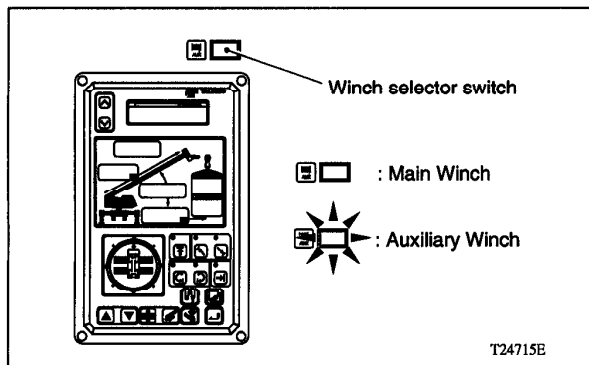

The winch selection alternates between main winch and auxiliary winch each time the winch selector switch is pressed. When auxiliary winch is selected, the winch selection indicator lamp lights up.

[NOTICE]

◆ For boom lift, always employ the main winch.

Selecting Jib Mounted Condition

⚠ WARNING

⚠ If the jib mounting/dismounting state is set improperly, the load moment indicator can not detect the actual load precisely. The crane operation in this condition could create hazard.

The jib can be dismantled from the crane body when it is not used. The reduced mass of the crane body after jib removal will influence the precision of the load moment indicator. Use this switch to set the jib mounting /dismounting state to the load moment indicator.

◆ The key can be inserted in/removed from either "REMOVED" or EQUIPPED" position.

- (1) "REMOVED": Select this position when the jib is dismantled. The jib removed indicator lamp will light up.
- (2) "EQUIPPED": Select this position when the jib is mounted. The jib removed indicator lamp will go off.

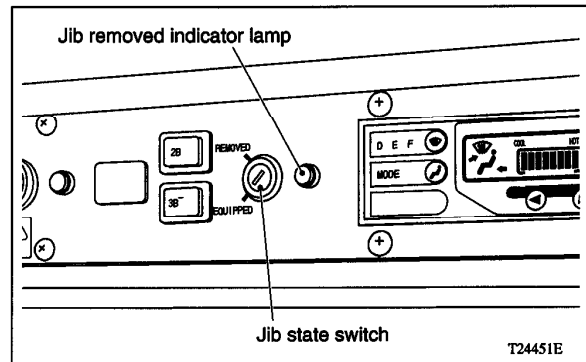

Display and Disposition of Failure Messages

When failure messages are shown on the load moment indicator moment display, the AML buzzer sounds for 3 seconds. Stop working and take appropriate action.

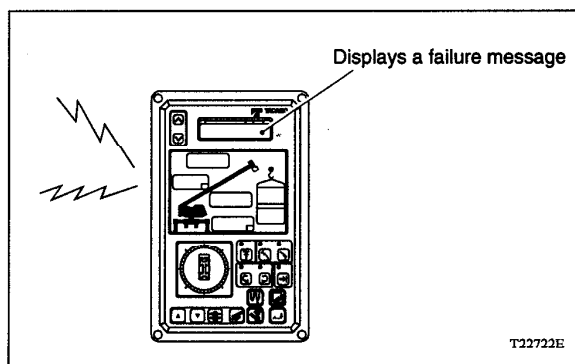

T22722E

Messages	Meanings	Causes	Solutions
[Warning:0001] [Warning:0002] [Warning:0003] [Warning:0004]	R.F. outrigger retracts R.R. outrigger retracts L.F. outrigger retracts L.R. outrigger retracts	Outrigger beam retracts and extended width decreases.	Re-extend outrigger.
[Error:0006]	Pins inserted in jib	Jib connecting pin and jib set pin inserted.	Set the pins on the jib to normal conditions.
[Warning:0011]	Connecting pin uninserted	Jib connecting pin is not inserted.	
[Warning:0010]	Approaching to the swing limit	The boom is swung close to the registered swing limit. (This message appears while the swing limit is registered and the swing stop cancel switch is set to OFF.)	Swing in the opposite direction. Cancel the swing limit function.
[Warning:0012]	Rearward instability	The load exceeds the rearward tipping load limit as the boom is swung from over-front or over-rear toward over-side during on-rubber operation.	Swing in the opposite direction. Lower the boom.
[Warning:0015]	Stoppage due to overwinding (with overwind cut-out function deactivated)	Main (or auxiliary) winch is wound excessively.	Hoist down the main (or auxiliary) winch.
[Warning:0024]	Stops by overwinding		
[Error:0016]	Operation state not applied <case 1>	Wrong registration of operation state (boom lift, jib lift, single top lift, outrigger)	Register operation state again.
[Error:0017]	Operation state not applied <case 2>		
[Warning:0023]	Stops at moment ratio 100%	Moment ratio beyond 100 %	Hoist down winch. Raise boom angle. Retract boom.
[Warning:0025]	Stop for rearward stability	The load reaches the rearward stability capacity limit as the boom is raised or retracted during on-rubber operation.	Lower the boom. Extend the boom.
[Warning:0026]	Upper boom angle restricted.	Boom is raised above the upper boom angle restriction.	Lower the boom. Cancel upper boom angle restriction.
[Warning:0027]	Lower boom angle restricted	Boom is lowered below the lower boom angle restriction.	Raise the boom. Cancel lower boom angle restriction.

Middle/Minimum Extension Procedure

◆ When using the outriggers at the minimum length position, extend the jack cylinders but not the slider beams.

1. By the same procedure with the outriggers' full extension procedure, extend outrigger beams to the middle extension marks (21'11-3/4" [6.7 m] or 18'1/2" [5.5 m]).

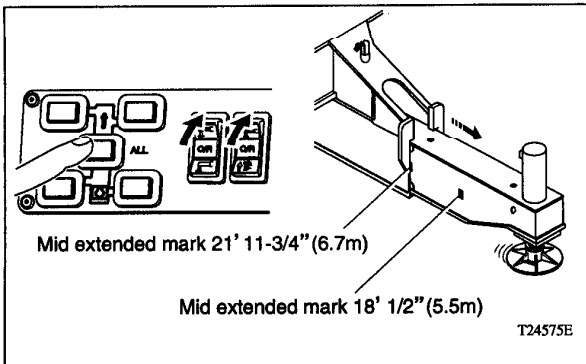

2. Insert all four lock pins in the outrigger pin holes to lock the outrigger beams in place.

3. By the same procedure with the outriggers' full extension procedure, extend all the jack cylinders.

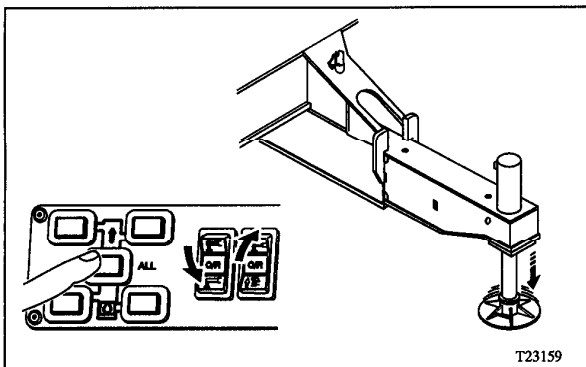

1. Fully retract the boom.
 - ◆ While the boom is not fully retracted, the telescoping mode cannot be changed even if the telescoping mode I/II switch is pressed.
2. Press the telescoping mode I/II switch to select the boom telescoping mode I or II.
 - ◆ Make sure that the indicator lamp that corresponds the selected mode lights up.

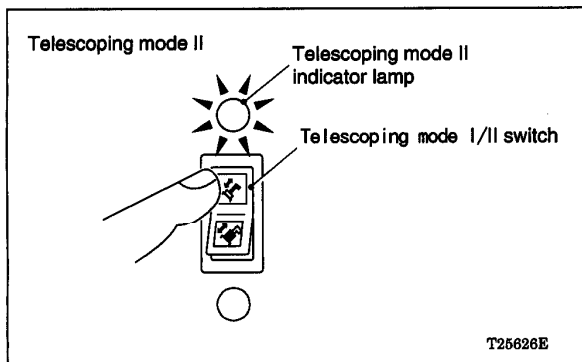
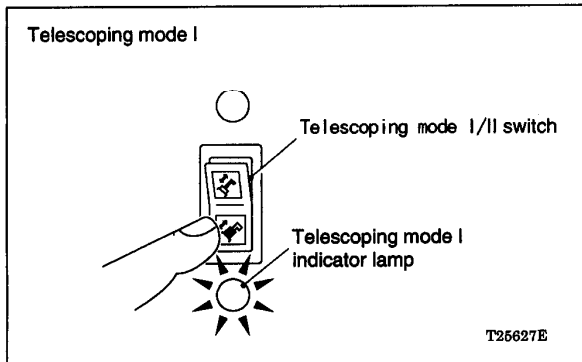

Boom Telescoping Control Pedal

This pedal is for extending and retracting the boom.

- ◆ You can telescope the boom by using the boom telescoping control pedal independent of the boom telescoping/auxiliary hoist control selector switch condition.

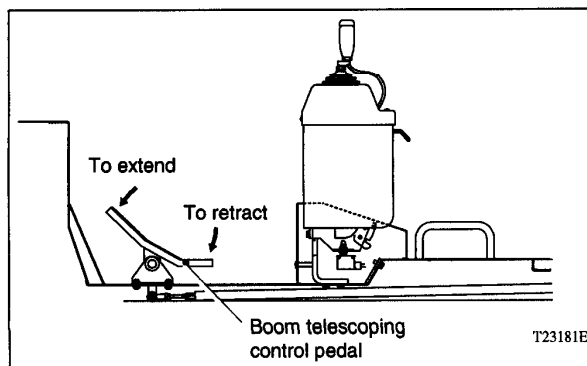

Extending and Retracting the Boom

⚠ WARNING

- ⚠ Moving the control levers abruptly is dangerous because it causes the load to bounce and swing. Operate levers slowly and carefully.
- ⚠ When the boom is extended, the working radius increases. Be alert to any sign of overloading when extending the boom.
- ⚠ Do not push or pull the load by telescoping the boom. This practice can damage the crane and lead to an accident.
- ⚠ A boom telescoped incorrectly can collapse if a lift is made in this condition. Watch out for any error in the boom section telescoping sequence while operating the crane.
- ⚠ Check that the boom telescoping operation indicator lamp is lit before operating the lever; otherwise the crane can move regardless of your intent and create a hazard.

[NOTICE]

- ◆ The extended boom retracts, though slightly, in course of time, due to hydraulic oil temperature change. For example, 15 ft (5 m) extended boom retract by approx. 1.6 in (40 mm) along with lowering of temperature by 18°F (10°C). Besides temperature, the boom's telescoping conditions, boom angle, lubrication, etc. affect the amount of retraction. For boom retraction prevention, use the following precautions:
 - Do not extend the boom when the hydraulic oil temperature is extremely high. (Make the oil cooler function while the hydraulic oil is cool to prevent its temperature from getting too high.)
 - Manipulate the telescoping control lever slightly to the EXTEND direction to mitigate the oil effect.

On-rubber Operation

⚠ WARNING

⚠ Do not use the jib. Do not perform boom lift nor single top lift when the boom length exceeds 91 ft (27.75 m).

⚠ Do not operate the crane unless tire's air pressure is at the specified value. (On-rubber operation is allowed assuming the tires are pressurized as specified.)

⚠ The crane may overturn if the boom sways much because the outriggers are not set. Take care that the load does not sway during crane operation.

[NOTICE]

◆ Rated lifting capacities for on-rubber operation are values when the crane is installed on the firm level ground. Inclined ground or soft ground do not satisfy the rated lifting capacity values. Always take the ground conditions into account for operation.

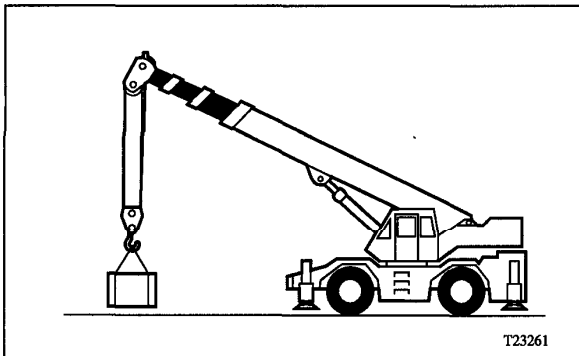

◆ Pay attention to the moment display on the load moment indicator during operation. The crane is supported only by the tires. When overloading conditions occurs, the crane operation stops. But the inertia makes the crane to oscillate to and fro, or right and left.

Stationary

⚠ WARNING

⚠ The only case for over-front performance is when shown on the load moment indicator by the over-front position symbol. Otherwise the crane is under all 360° performance control.

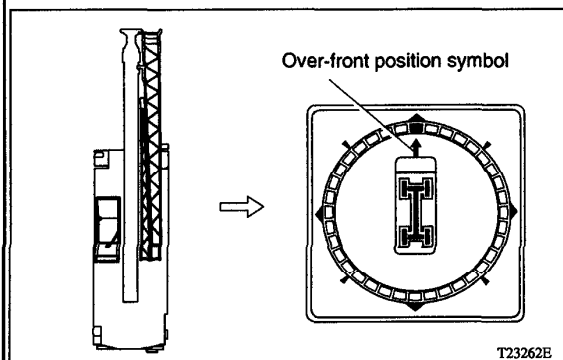

⚠ Do not swing the boom free. Set the swing free/lock selector switch to LOCK.

⚠ During on-rubber operation, the crane does not stop automatically even when an overload condition occurs by boom swing. Also remember that swing limit function does not work. Take care when swinging the boom during on-rubber operation.

⚠ Do not lift up a load in over-front area and swing it sideways unless the load is under the 360° performance.

[NOTICE]

◆ Register "on-rubber stationary operation" on the load moment indicator.

1. Set the crane as follows:
 - (1) Fully retract the boom, level it and place it over-front.
 - (2) Stop on firm and level ground. The gearshift lever must be set in the "N" position.
 - (3) Activate the parking brake.

Single Top (Option)

Components

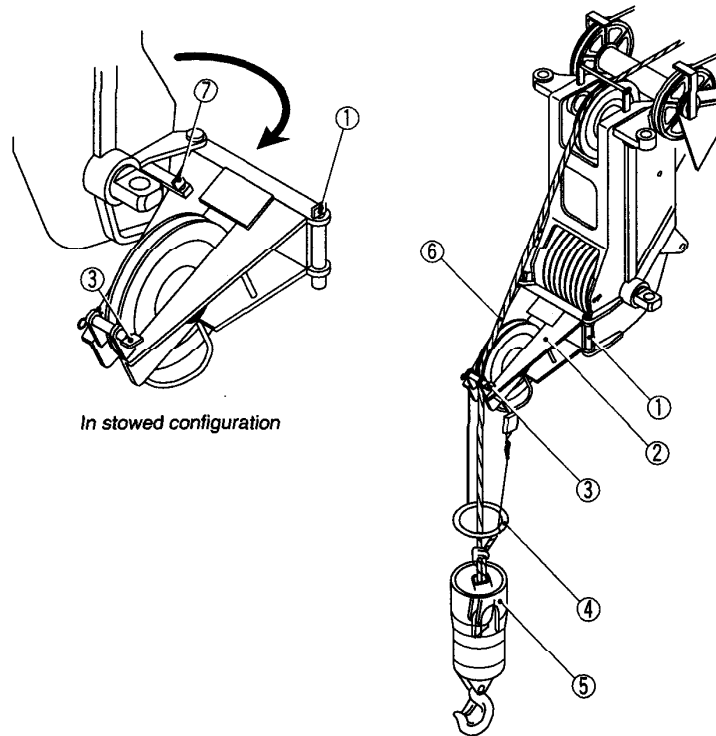

T24577E

1. Connecting pin
2. Single top
3. Rope guide pin
4. Weight for anti-twoblock device
5. Auxiliary hook block
6. Wire rope
7. Stowing pin

Mounting the Base Jib

⚠ WARNING

⚠ Do not lower the boom to an angle below 0°. This action could cause the jib to disengage and drop off.

⚠ Always make sure that either a stowing pin or pivot pin is in position before starting any operation. Without these pins in position, the jib will drop off when an operation is started.

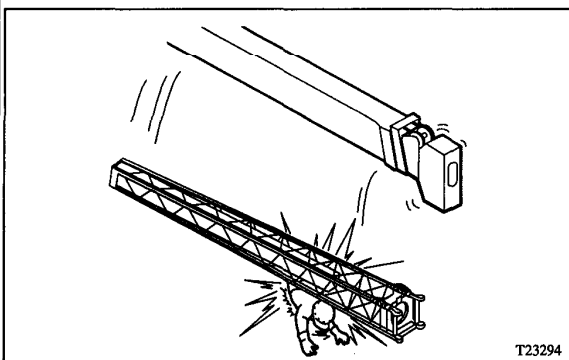

T23294

⚠ Take the necessary precautions to ensure that nobody enters the area over which the jib will swing. Anyone standing in this area could be injured. Also check the adjacent work area for any structure or other obstruction that may present a problem when operating the jib.

⚠ The load moment indicator's control functions and the automatic stop function are deactivated when the jib set status is selected on the load moment indicator. Mount the jib carefully with no load on the crane.

⚠ When working at an elevated position, use a platform or scissor lift to prevent falling and ensure safety.

⚠ Use the attached bolts and cotter pins to secure the lock pin, rope guide pins, and stowing pin in position.

[NOTICE]

◆ Select the jib set status on the load moment indicator before operating the jib; otherwise the jib lock pin switch nor jib mounting/stowing switch will not work.

◆ Before operating the winch, make sure that the wire rope is not wound disorderly on the winch drum.

◆ Retract the boom fully before mounting/stowing the jib. The jib cannot be mounted/stowed if the boom is extended even slightly.

1. Set the crane on fully extended outriggers in a location large enough for mounting the jib.

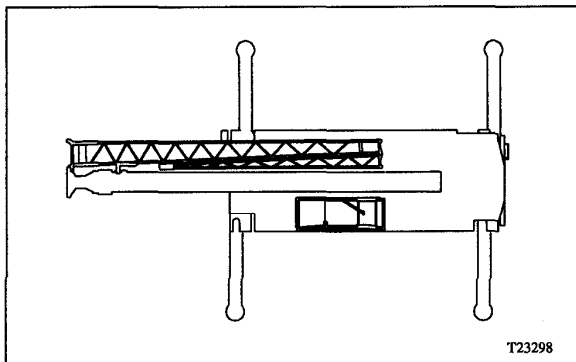

T23298

2. Take the auxiliary hook block out of stowage, and place it below the expected position of the jib tip.

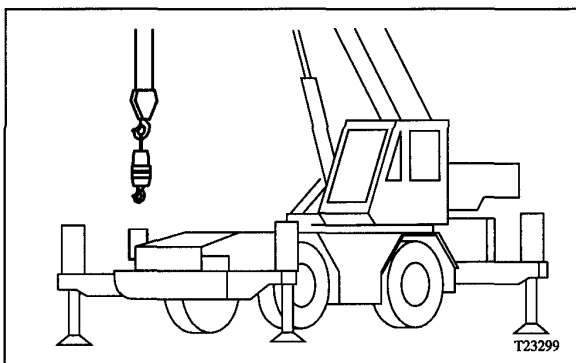

T23299

3. Select the jib set status on the load moment indicator.

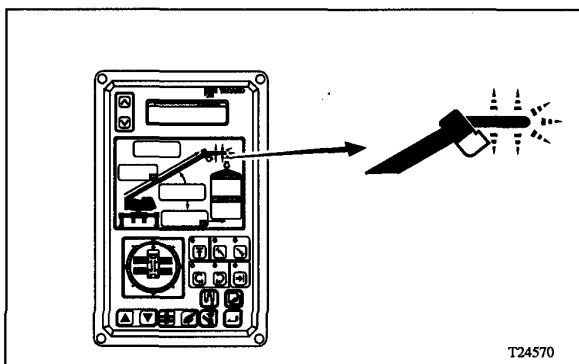

T24570

[NOTICE]

◆ Take care of the rope socket orientation when attaching it to the bracket. (See the figure below.) If positioned inversely, the rope socket hits the jib at the lower face when the winch is operated, and the socket will be damaged.

15. Attach the rope socket to the bracket on the base jib section with the fixing pin.

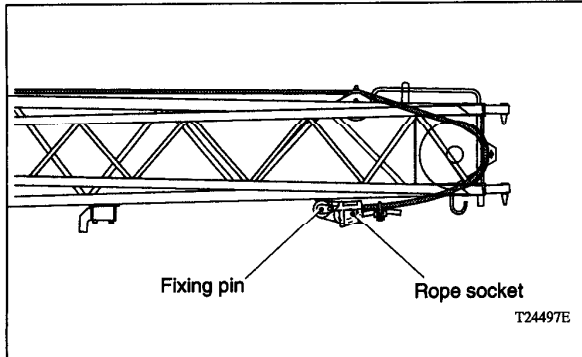

16. Hoist up the winch until the rope becomes tense and then hoist up the winch slowly to align the connecting pin (H) with the pin hole on the upper side of the base boom section.

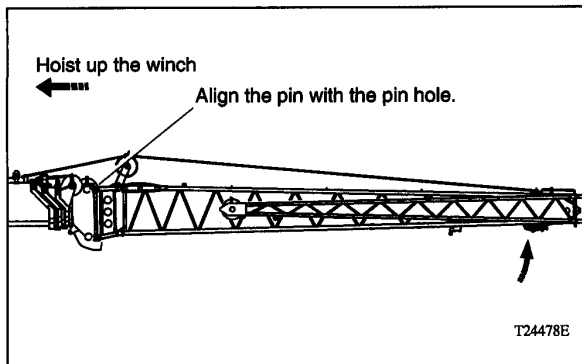

17. After making sure that the connecting pin (H) is aligned with the pin hole on the upper side of the base jib section, insert the connecting pin (H) into the pin hole using the jib handle.

◆ Insert the connecting pin (H) properly; the red tape on the threaded portion should be exposed.

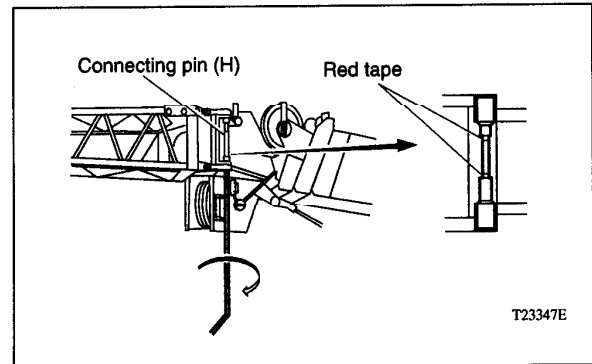

18. Hoist down the winch until the wire rope becomes slightly slack. Then remove the rope socket from the bracket on the base jib section.

19. Attach the guide rope to the head of the top jib section.

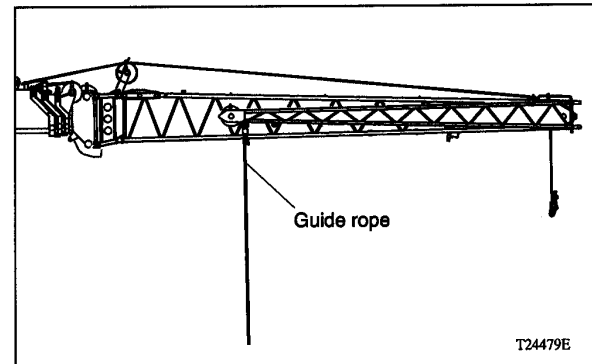

20. Raise the boom to the 3° boom angle (while the jib offset angle is -0.5°).

14. Stow the stowage support using the jib mounting /stowing switch. The base jib section will move toward the boom.

◆ Make sure that the jib mounting/stowing operability indicator lamp is lit. While it is unlit, the jib mounting /stowing cylinder does not move. The lamp does not light up if the jib lock pin cylinder is not retracted fully.

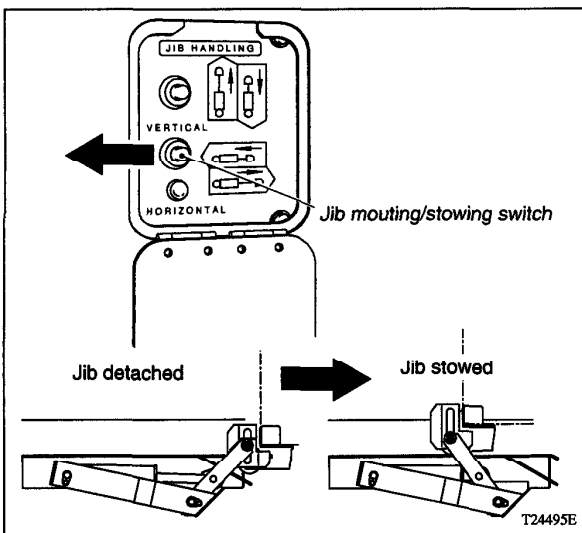

15. Flip the jib lock pin switch upward to connect the jib lock pin at the center support on the boom with the jib.

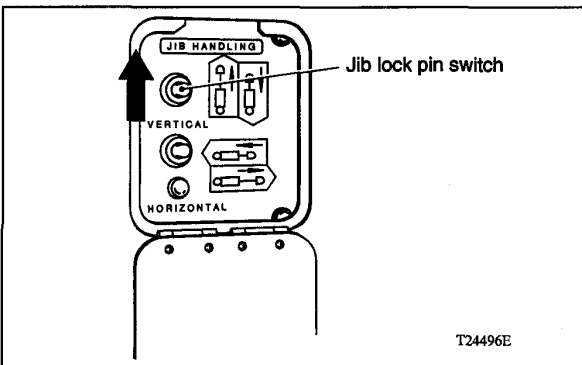

◆ After the jib lock pin at the center support is extended, marks on the both sides of the cylinder (red) and the jib (blue) at the center support will be aligned.

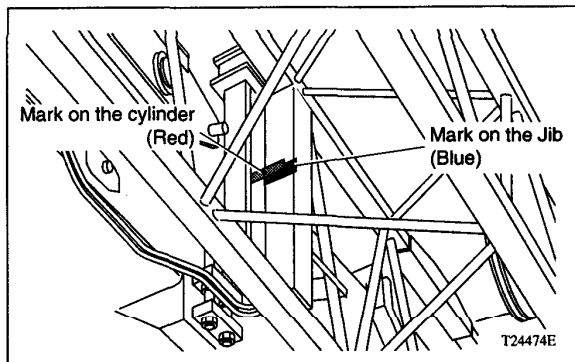

◆ Make sure that the jib is connected with the jib lock pin at the center support.

⚠ WARNING

⚠ Make sure that the boom angle is horizontal or over before removing the pivot pin (G). If the pin is removed while the boom is lowered below horizontal, the jib can fall.

⚠ To prevent the jib from falling off, secure the jib by inserting the set pin immediately after removing the pivot pin (G).

16. Remove the pivot pin (G) using the jib handle.

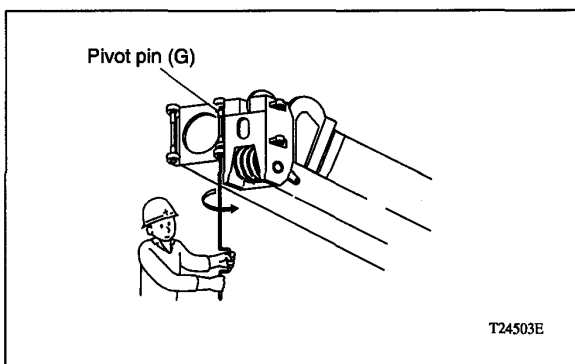

Equipment Inside the Cab

Components

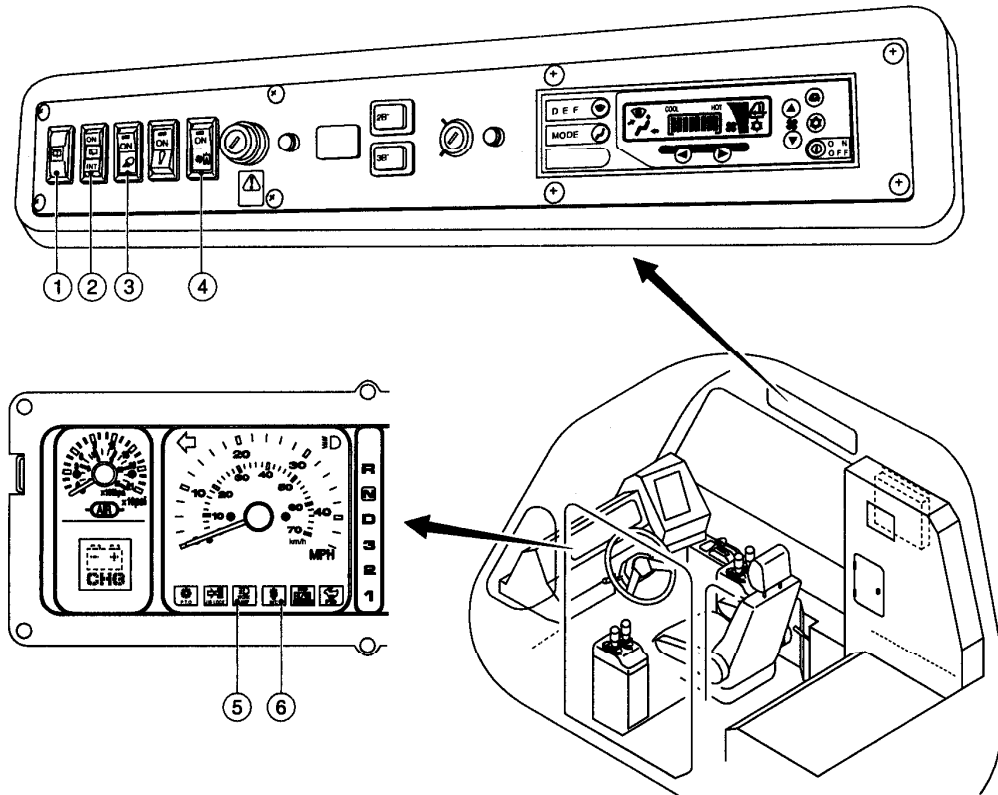

T30322

- 1. Roof washer switch
- 2. Roof wiper switch
- 3. Flood lamp switch

- 4. Oil cooler switch
- 5. Flood lamp indicator lamp
- 6. Hydraulic oil temperature (50°C) warning lamp

Roof Washer Switch

[NOTICE]

- ◆ Do not use the wipers on dry glass; doing so will damage the glass. Wet glass by spraying the window with washer fluid before using the wipers.
- ◆ Never spray washer fluid continuously for more than 3 seconds and do not operate the washer switch when there is no window washer fluid. This practice may burn out the pump.

Washer fluid can be sprayed on the roof glass by when this switch is pressed.

Roof Wiper Switch

The roof wiper switch is used to turn the roof wiper ON and OFF.

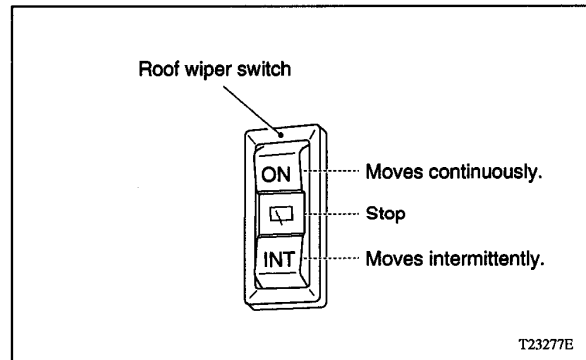

T23277E

System/Component		Check point	Pre-operational inspection	Periodic inspection		
				100 hrs		
				1 month		
Power transmission system	Torque converter, transmission	External appearance		●		
		Operation, oil level, oil leaks		●		
		Clutch pressure, operation	●	●		
		Clean air breather, strainer and filter			*3	
		Shifting between drive mode select gears		●		
	Propeller shaft	External appearance		●		
		Runout, worn spline		●		
		Differential, planetary gear	Oil level, oil leaks		●	
			Clean air breather		●	
	Other components	Lighting device	External appearance	●	●	
Operation			●	●		
Horn, wiper, turn signal		External appearance	●	●		
		Operation	●	●		
		Worn blade		●		
Rearview mirror, reflector		Mirror condition	●	●		
Meter and gauges		External appearance		●		
		Operation	●	●		
Exhaust piping, muffler		External appearance		●		
		Muffler function		●		
Lubrication	Lubricate each grease nipple	●	●			

*1: Every 250 hrs or every 3 months

*2: Every 500 hrs or every 6 months

*3: Every 1,000 hrs or once a year

Axle (Planetary Gear) Oil Level

Check Every 100 Hours

or Once a Month

Axle (Planetary Gear) Oil

Replacement Every 2,000

Hours or Every 2 Years

⚠ WARNING

⚠ The axles are very hot immediately after traveling. Let the axle cool down until you can touch it with your bare hand before starting maintenance work.

Checking Oil Level

1. Extend the outriggers and set the crane level.
2. Rotate the tire by hand until "OIL LEVEL" is positioned as shown. Wear protective gloves.

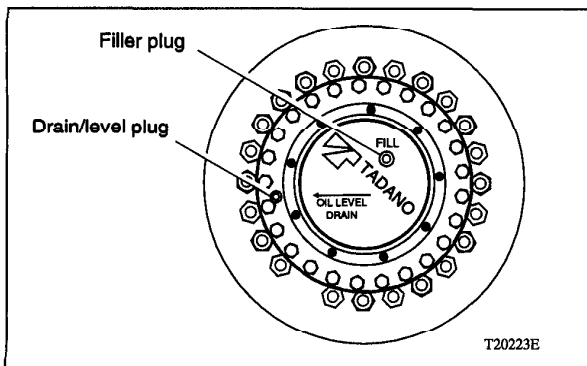

3. Remove the drain/level plug and check the oil level. There is no need to add oil if the oil level is up to the bottom of the plug hole. If low, remove the filler plug and add oil through the filler plug hole.

4. Install and tighten the filler plug and the drain/level plug.

Replacing Oil

1. Extend the outriggers and set the crane level.

2. Rotate the tire by hand to move the drain/level plug to the lowest position as shown. Wear protective gloves.

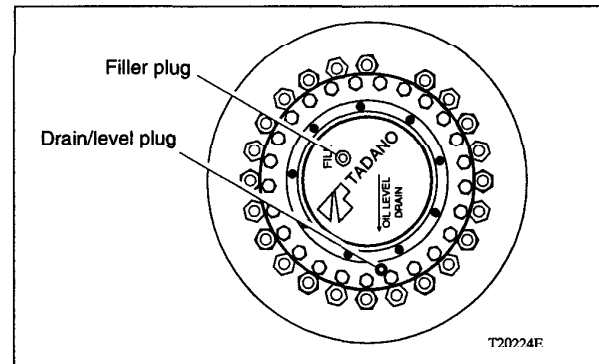

3. Place an oil pan under the drain plug.
4. Remove the drain/level plug and filler plug to drain the oil.
5. After all the oil has drained out, rotate the tire by hand until "OIL LEVEL" is right-side up and horizontal.
6. Pour new gear oil through the filler plug hole until the oil reaches the top of the drain/level plug hole.
7. Once the oil has been supplied, install and tighten the filler plug and drain/level plug.

Brake Fluid Level Check

.....Once a Day

⚠ WARNING

⚠ If the brake fluid is leaking, the brakes will cease to function, an extremely dangerous condition. If the fluid level is low, check the brake system for leaks. If there are no leaks but the fluid level has lowered, the disc brake pads may be worn. Inspect the pads for excessive wear.

[NOTICE]

◆ We recommend that you use only brand new brake fluid for replenishment or replacement.

Make sure the fluid level is between H and L. If the level is low, remove the cap and add fluid.

- ◆ There are 2 brake fluid reservoirs located in the center right side of the carrier.
- ◆ Fasten the cap where the match marks meet on the cap and the tank.

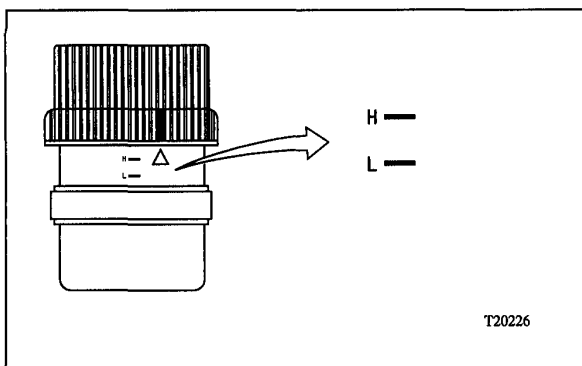

Brake Fluid Replacement

.....Every 1,000 Hours

or Once a Year

For brake fluid replacement, contact the nearest TADANO distributor or dealer.

Disc Brake Pad Wear Check

.....Every 250 Hours

or Every 3 Months

⚠ WARNING

⚠ Using the brakes when the pads are at or near their wear limit will not only damage the disc plates but also cause the brakes to quit working altogether, an extremely dangerous condition. If an inspection reveals that the pads are near their wear limit, have the nearest TADANO distributor or dealer replace the pads immediately.

⚠ Brake pads whose thickness is within working specifications can still be carbonized by heat build-up, worn unevenly or scratched. If scratching, abnormal wear or rust is discovered on the disc plates during inspection, the pads must be removed and inspected. If the condition is severe, the disc plates or pads may have to be replaced. Have the nearest TADANO distributor or dealer inspect them immediately.

[NOTICE]

◆ You need to remove the pads for closer inspection or can use a check gauge shown below for less closer checks.

If the pads are not undergoing rapid wear, only the outer pad may be worn. At this time, remove the pad for a closer check.

◆ Pad wear inspection should be carried out for all wheels. If, as a result of inspection, even one pad is worn to near its wear limit, replace all pads, or pairs of pads together; the left and right front pads or the left and right rear pads.

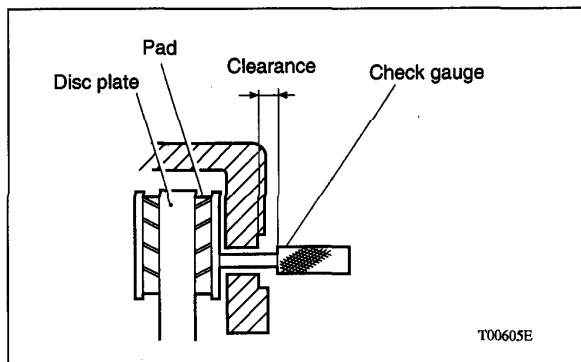

Line Filter Cleaning (Outrigger Circuit) Every 1,000 Hours or Once a Year

◆ Location: front left side of the rotary joint (inside of the crane frame)

Clean the filter element as follows:

- (1) Remove the case using a wrench (24 mm).
- (2) Remove the filter element. Wash its surface with a soft nylon brush in kerosene.
- (3) Apply compressed air of 43–57 psi {300–400 kPa} from the inside of the filter element and dry it.
- (4) Apply the hydraulic oil to the O-ring, install the filter element, and attach the casing.

◆ Tightening torque: 28.8–36.2 ft-lb {39–49 N·m}

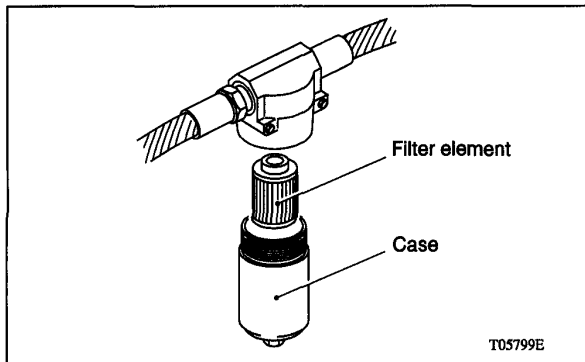

Remove the line filter case in the transmission and replace the filter element.

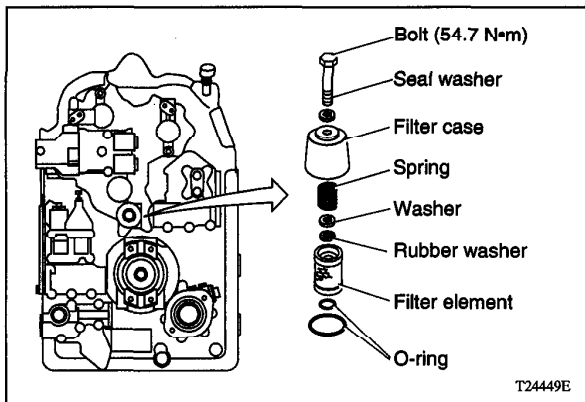

Line Filter Replacement (Automatic Stop Circuit) · Every 2,000 Hours or Every 2 Years

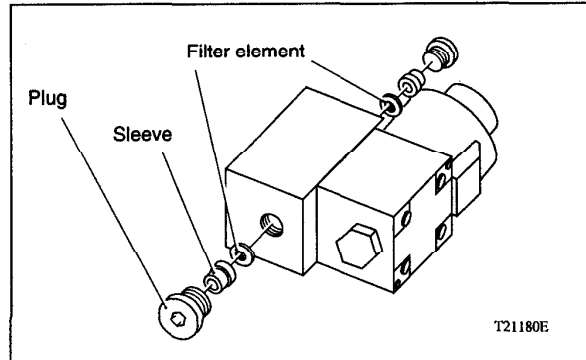

Line Filter Replacement (Steering Circuit) Every 2,000 Hours or Every 2 Years

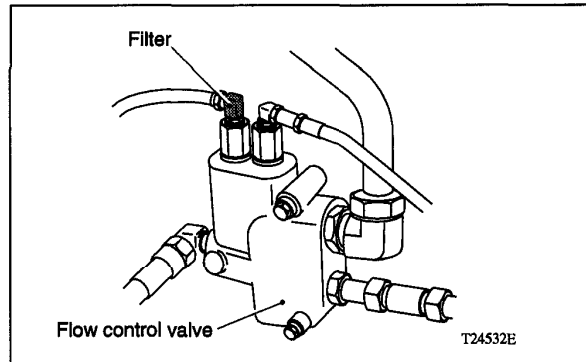

Line Filter Replacement (Return Circuit) Every 2,000 Hours or Every 2 Years

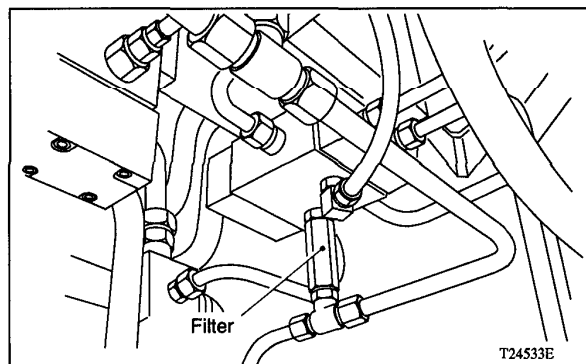

3. Hoist the hook block up and down several times to distribute any remaining twists evenly throughout the rope. If, after this action, twists still remain, correct again.

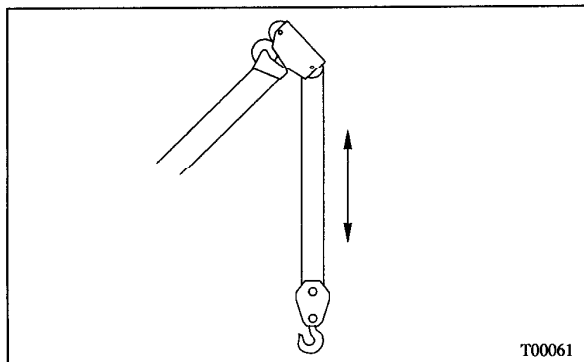

Correcting the Torsion of the Wire Rope

[NOTICE]

◆ Wire ropes may lose its structural elongation and be untwisted with use. Using such wire ropes for a long time can lead torsions to gather at the rope ends, damaging the wire ropes.

To settle twisting condition of the wire rope, re-reeve the wire ropes regularly to remove the torsions on the rope ends. It is essential for a while after the wire rope has been replaced.

Wire Rope Replacement

Criteria for Replacing Wire Ropes

⚠ WARNING

⚠ If a wire rope breaks during operation, a serious accident could occur. Check the wire ropes at regular intervals. Wire ropes that do not meet even one of the criteria given below should be replaced immediately.

Perform routine and periodic (monthly) inspections of the wire ropes for breaks, wear, corrosion, deformation, arcing or heat effects, oil coat condition, and rope end condition. If any of the following conditions 1 through 5 exist, replace the wire rope.

◆ If the end of wire rope is not in proper condition, repair or cut.

1. In running ropes: six randomly distributed broken wires in one lay, or three broken wires in one strand in one lay.
2. Wear of one-third of the original diameter of outside individual wires. Evidence of kinking, crushing, bird caging, or any other damage resulting in distortion of the rope structure.
3. Evidence of any heat damage from any cause.
4. Reductions from nominal diameter of more than:
 - 1/64 inch for diameters up to and including 5/16 inch
 - 1/32 inch for diameters 3/8 to 1/2 inch inclusive
 - 3/64 inch for diameters 9/16 to 3/4 inch inclusive
 - 1/16 inch for diameters 7/8 to 1-1/8 inches inclusive
 - 3/32 inch for diameters 1-1/4 to 1-1/2 inches inclusive
5. In standing ropes: more than two broken wires in one lay in sections beyond end connections, or more than one broken wire at an end connection.

Removing Wire Rope

1. Extend the outriggers and place the boom in the over-rear or an over-side area.

Overall Dimensions

No.	Dimension
1.	11' 5/8" (3,368 mm)
2.	12' 6-7/8" (3,833 mm)
3.	Max. extension width ··· 23' 7-1/2" (7,200 mm)
	Mid. extension width ··· 21' 11-3/4" (6,700 mm)
	Mid. extension width ··· 18' 1/2" (5,500 mm)
	Min. extension width ··· 9' 2-1/4" (2,800 mm)
4.	ϕ 1' 7-11/16" (ϕ 500 mm)
5.	11' 7-11/16" (3,548 mm)
6.	11' 11-13/16" (3,653 mm)
7. Overall width ·····	10' 10-1/2" (3,315 mm)
8.	13' 6-1/4" (4,120 mm)
9. Departure angle ·····	14.4°
10.	7' 10-1/2" (2,400 mm)
11. Wheel base ·····	12' 11-1/2" (3,950 mm)
12.	6' 6-11/16" (2,000 mm)
13. Approach angle ·····	17.6°
14.	25' 10-5/16" (7,880 mm)
15. Overall length ·····	46' 8-1/4" (14,230 mm)
16. Overall height ·····	12' 5-1/2" (3,800 mm)

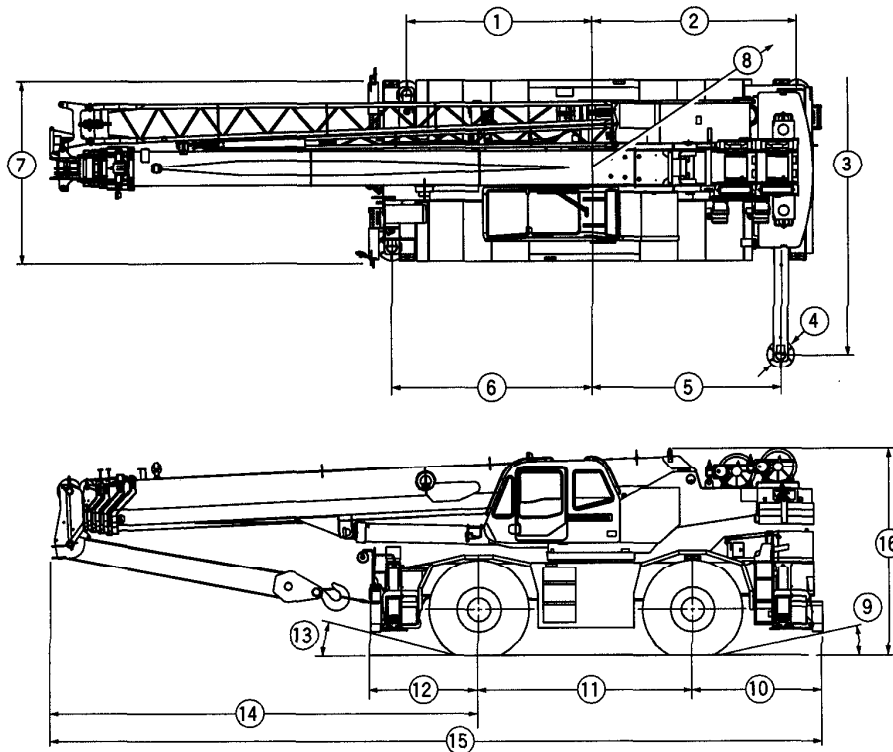

T25634

CLICK HERE TO **DOWNLOAD** THE COMPLETE MANUAL

- Thank you very much for reading the preview of the manual.
- You can download the complete manual from: www.heydownloads.com by clicking the link below



- Please note: If there is no response to CLICKING the link, please download this PDF first and then click on it.

CLICK HERE TO **DOWNLOAD** THE COMPLETE MANUAL