

Operation Manual

Operation Manual

Rough Terrain Crane **GR-800EX**

Model: GR-800EX-3
Serial No.: 549096 –

Operate this machine only after reading this Manual.
Keep this Manual in the cab so that it can be reviewed
at any time.

CLICK HERE TO **DOWNLOAD** THE COMPLETE MANUAL

- Thank you very much for reading the preview of the manual.
- You can download the complete manual from: www.heydownloads.com by clicking the link below



- Please note: If there is no response to CLICKING the link, please download this PDF first and then click on it.

CLICK HERE TO **DOWNLOAD** THE COMPLETE MANUAL

Contents with Illustrations

Traveling System

Inside Cab

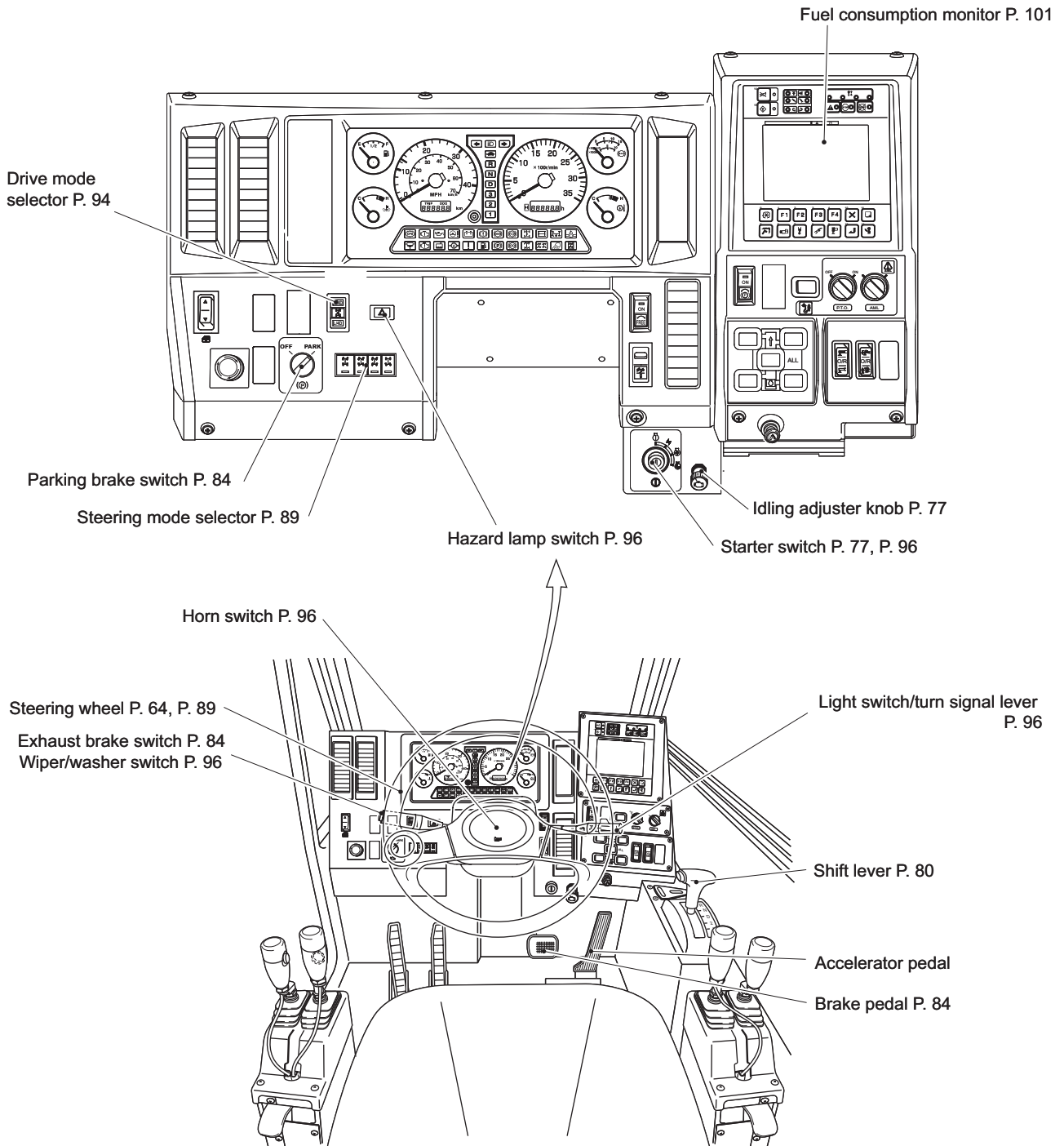

K11428-00E

MEMO

• Park on Flat and Safe Place

Avoid parking the vehicle on a slope. When you park the vehicle, stop it on a level ground and apply the parking brake.

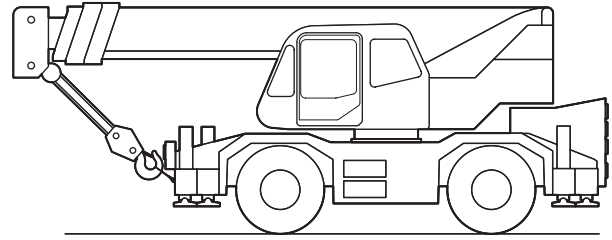

K01435-000

• Set Stoppers to All Tires If You Park on a Slope Unavoidably

When it is unavoidable to park the machine on a slope, park it parallel to the direction of the inclination. Apply the parking brake and set stoppers to the tires so that the machine does not move away.

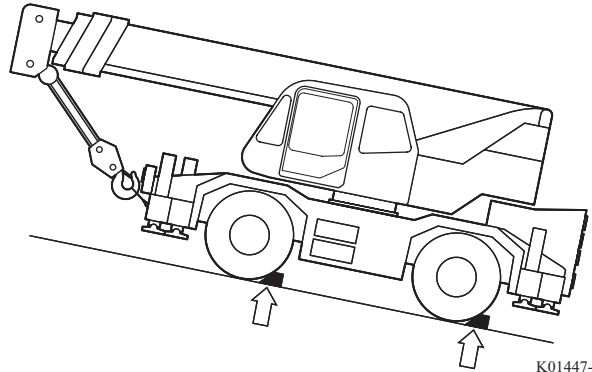

K01447-000

• Mind Safety of Surroundings When You Park Disabled Vehicle on Road

When you park a disabled vehicle on a road, set up flags, fencings, flashing lamps and triangle reflectors. Make the vehicle easily noticeable from other vehicles even at night. Be careful that the parked machine does not hinder the traffic of other vehicles and pedestrians.

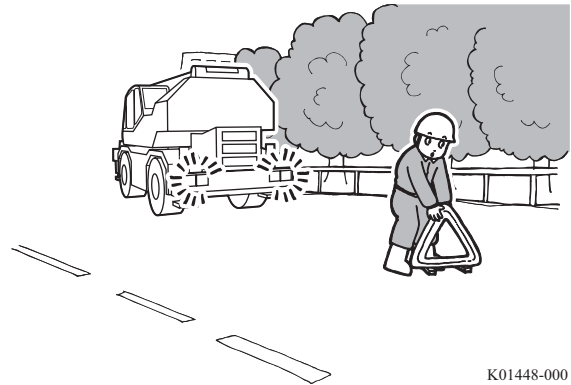

K01448-000

• When You Leave Machine

If you leave the machine with the engine running or the starter switch key inserted, unauthorized persons can operate the machine. When you leave the machine, use the precautions below:

- Park the vehicle on a level ground and apply the parking brake.
- Apply all the brakes and locks, and set the levers to neutral position.
- Stop the engine, and pull out the key from the starter switch.
- Lock all the doors and covers.

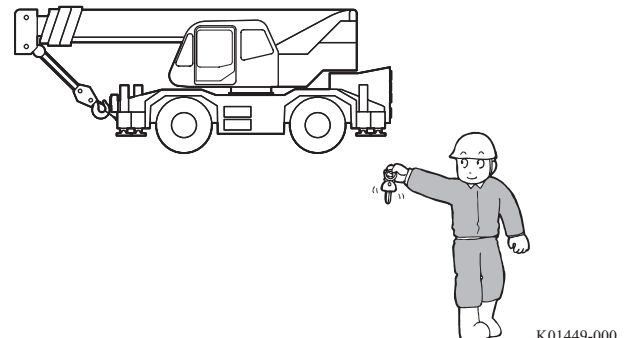

K01449-000

• Before Leaving Cab

Before leaving the operator's cab, take the following measures.

- Lower the load onto the ground.
- Fully retract the boom and stow them.
- Apply all the brakes and drum locks (if equipped).
- Return the control levers to the neutral position.
- Stop the engine, and pull out the key from the starter switch.
- Lock all the doors and covers.

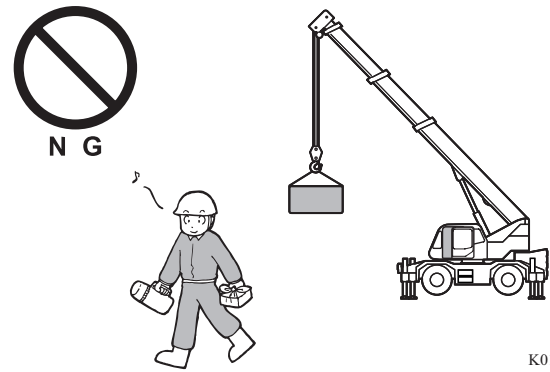

• Do Not Let Person Other than Operator Get on Machine

If any person other than the operator ride the machine, the person can be caught by or fall off the machine. Presence of other persons also hinders the operation.

Do not allow any person other than the operator to get on the machine.

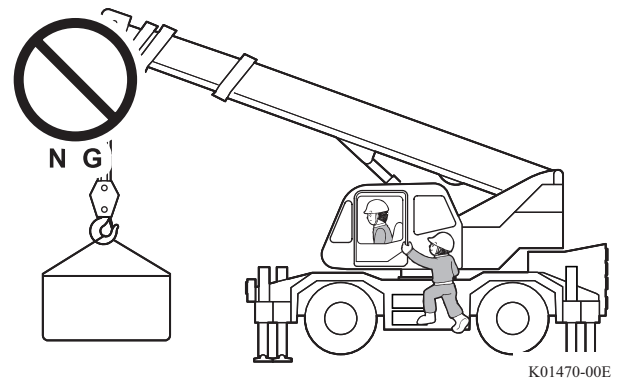

(1) Being crushed by boom



343-912-01430
343-912-01430-0

(2) Caution for jib mounting and stowing

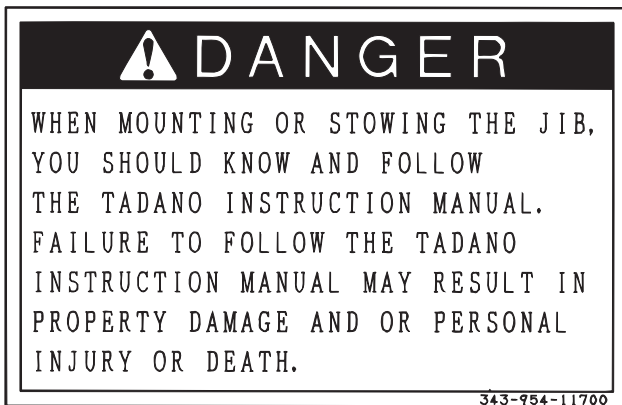

343-954-11700
343-954-11700-0

(4) Prevention of jib falling

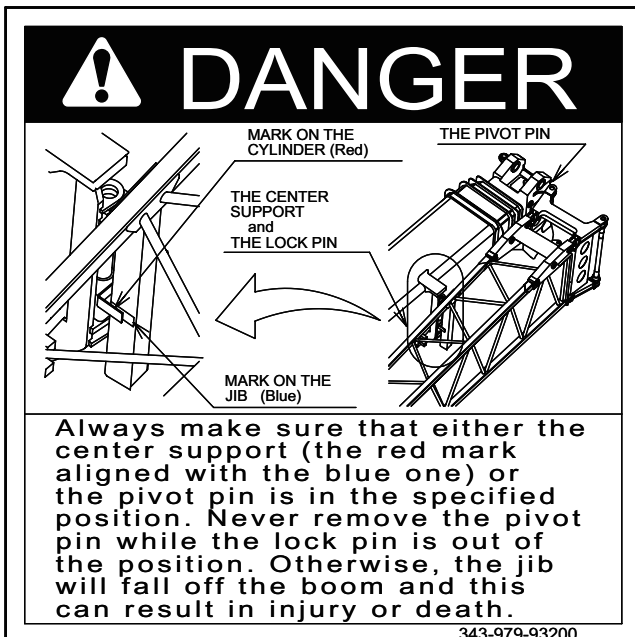

343-979-93200
343-979-93200-0

(5) Prevention of jib falling



343-979-93300
343-979-93300-0

(6) Being crushed by superstructure



343-984-45120
343-984-45120-0

(7) Jib status selection

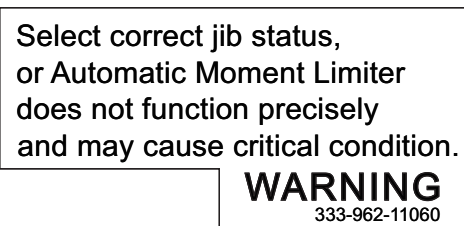

333-962-11060-0

(8) Caution for jib mounting and stowing

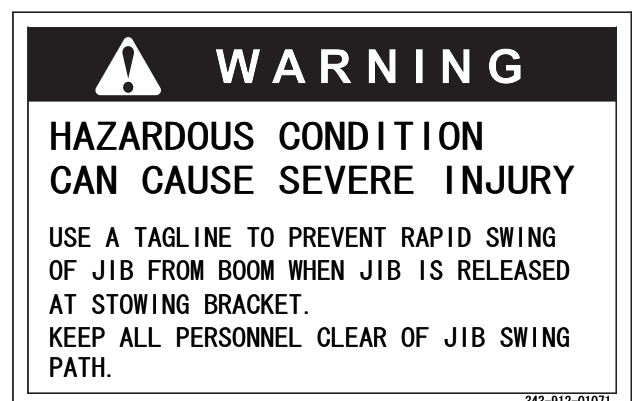

343-912-01071
343-912-01071-0

Entering Cab

The items below are explained here.

- Opening/Closing Door
- Opening/Closing Window
- Adjustment of Seat
- Adjustment of Steering Wheel
- Adjustment of Mirrors
- Fastening/Unfastening of Seat Belt
- Adjustment of Control Lever Stand
- Sunshade

Opening/Closing Door

NOTICE

**A door that is not closed properly can open unexpectedly during traveling.
Securely close the door before traveling.**

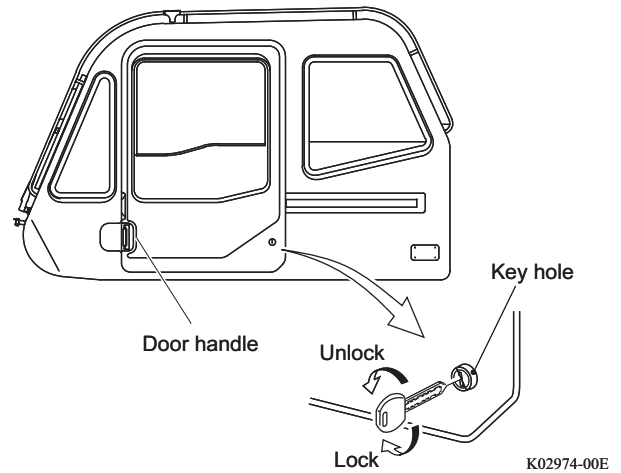

Locking and Unlocking from Outside of Vehicle

Insert the key, and turn it clockwise to lock and counterclockwise to unlock the door.

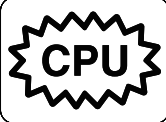
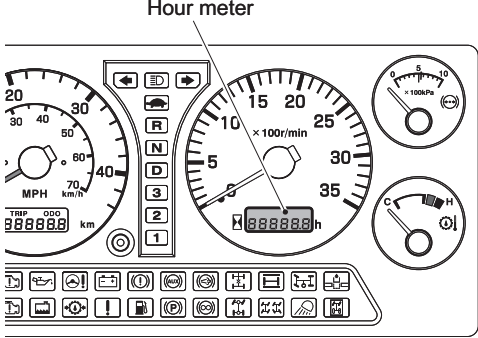
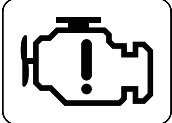
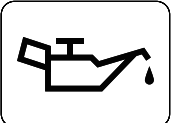

Warning Lamp

When any warning lamp lights up, immediately perform a remedy.
After the remedy, the warning lamp will go out.

Warning lamp	Meaning of indication	Remedy
 <p>CPU error warning K00357-00E</p>	<p>An abnormality has occurred in the computer system. (At the same time, an error code appears on the hour meter.) For details of the error codes, refer to "Error Codes Shown on Hour Meter" (page 72) section.</p>  <p>Hour meter</p> <p>K10496-00E</p>	<p>Stop the vehicle at a safe place, or stop crane operation and stow the crane. Change the starter switch to "OFF" and wait for 30 seconds or more, and then restart the engine. If the indication does not go out, make a note of the error code, and contact a TADANO distributor or dealer.</p>
 <p>Engine warning (red)/(yellow) K00358-01E</p>	<p>An abnormality has occurred in the engine control system. (At the same time, an error code appears on the hour meter.)</p>	<p>Stop the vehicle at a safe place, or stop crane operation and stow the crane. Change the starter switch to "OFF" and wait for 30 seconds or more, and then restart the engine. If the indication does not go out, make a note of the error code, and contact a TADANO distributor or dealer.</p>
 <p>Engine oil pressure warning K00359-00E</p>	<p>Engine oil pressure has dropped. (Normally, this appears when the starter switch is turned to "ON", and disappears when the engine is started.)</p>	<p>Stop the vehicle at a safe area and stop the engine. Examine the engine oil level. If this warning does not go out when the oil level is normal or even after the oil is added to the specified level, contact a TADANO distributor or dealer.</p>
 <p>Steering system warning K11481-00E</p>	<p>The steering filter is clogged.</p>	<p>Replace the steering filter.</p>

Transmission Operation

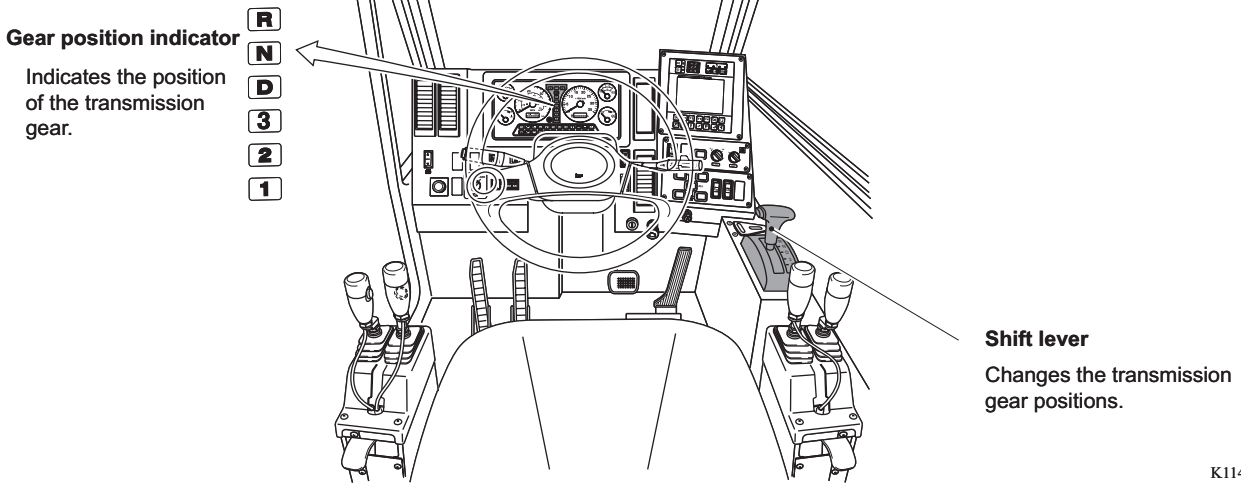

K11442-00E

Positions and Functions of the Shift Lever

⚠ WARNING

Carry out operations of ↑ ↓ without pushing the shift lever button. If you always push the shift lever button to operate the lever, you may accidentally change the lever to "R". This can cause an accident.

Shift lever button

R (Reverse)
Reverse
The gear is fixed to reverse.

N (Neutral)
Neutral
The engine drive power is not transmitted. This is a position for engine start, parking, and crane operation.

D (Drive)
Drive
Normal traveling
The gear is automatically changed from the first through third gear depending on the vehicle speed. The gear is fixed to the third gear in the driving mode of L/4D (4WD low speed traveling).

2 (Second)
2nd gear traveling
The gear is fixed to 2nd gear. Use this when ascending a long slope, or using engine braking to descend a slope, etc.

1 (Low)
1st gear traveling
The gear is fixed to 1st gear. Use this when ascending a steep slope, or requiring a strong engine brake force, etc.

↑ ↓ The lever can be moved without pressing the shift lever button.

↑ ↓ The lever can be moved only while the shift lever button is pressed.

K10116-00E

Selecting Steering Mode

⚠ DANGER

Do not travel on roads while the upper slewing structure is directed toward over-rear.
Before traveling, return the orientation of the upper slewing structure toward over-front.

⚠ WARNING

- The vehicle moves in an unusual manner in a special steering. Do not travel on roads in a special steering mode.
Travel on roads in the 2-wheel steering mode. Use a special steering only for driving in a work site, and travel at a speed of 15 km/h or less.
- While the upper slewing structure is directed toward the rear of the carrier, the vehicle is steered in opposite direction with the normal steering wheel operation. Remember that this movement is contrary to the movement when the upper slewing structure is directed to over-front. Be careful when you drive the machine.

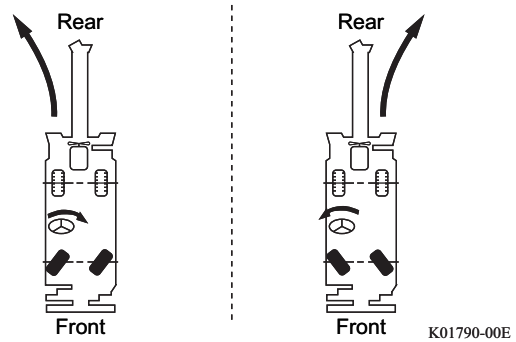

K01790-00E

Changing from the 2-wheel Steering Mode to a Special Steering Mode

The example here explains the steps for changing the 2-wheel steering mode to 4-wheel steering mode.

1. Set the front wheels straight, and stop the vehicle.

⚠ CAUTION

Do not change steering modes while the front wheels are steered left or right. Otherwise, the steering angle of the front wheels does not match that of the rear wheels after the mode change. It makes normal steering impossible.

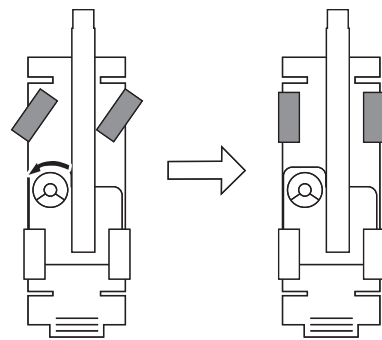

K02799-010

2. Set the shift lever to "N", and apply the parking brake.

Accessories in Cab

CAUTION
When you operate an accessory in the cab during traveling, be careful that safe driving is not hindered.

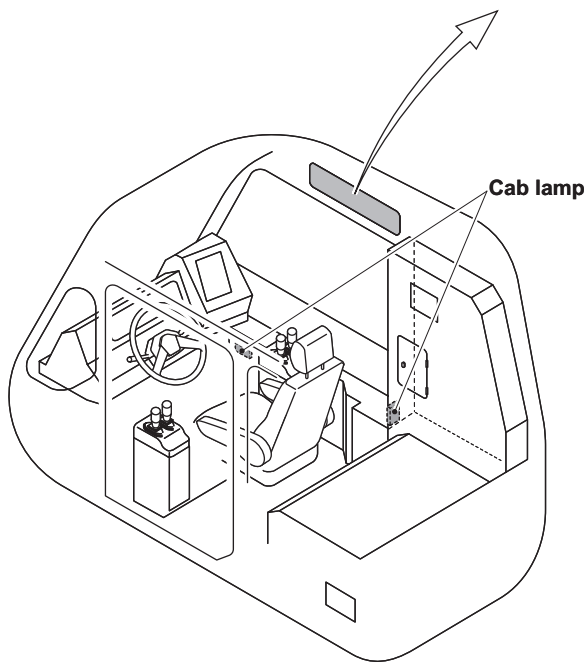
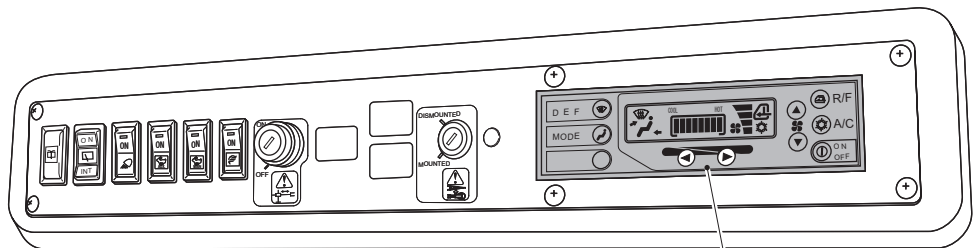
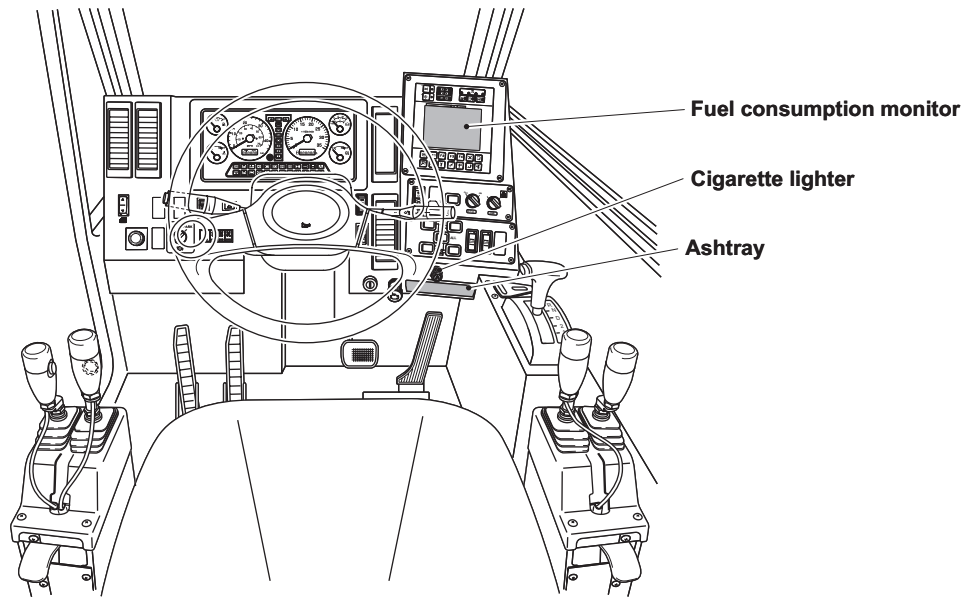

K11479-00E

GR-800EX-3_OM2-12E

Outside Cab Accessories

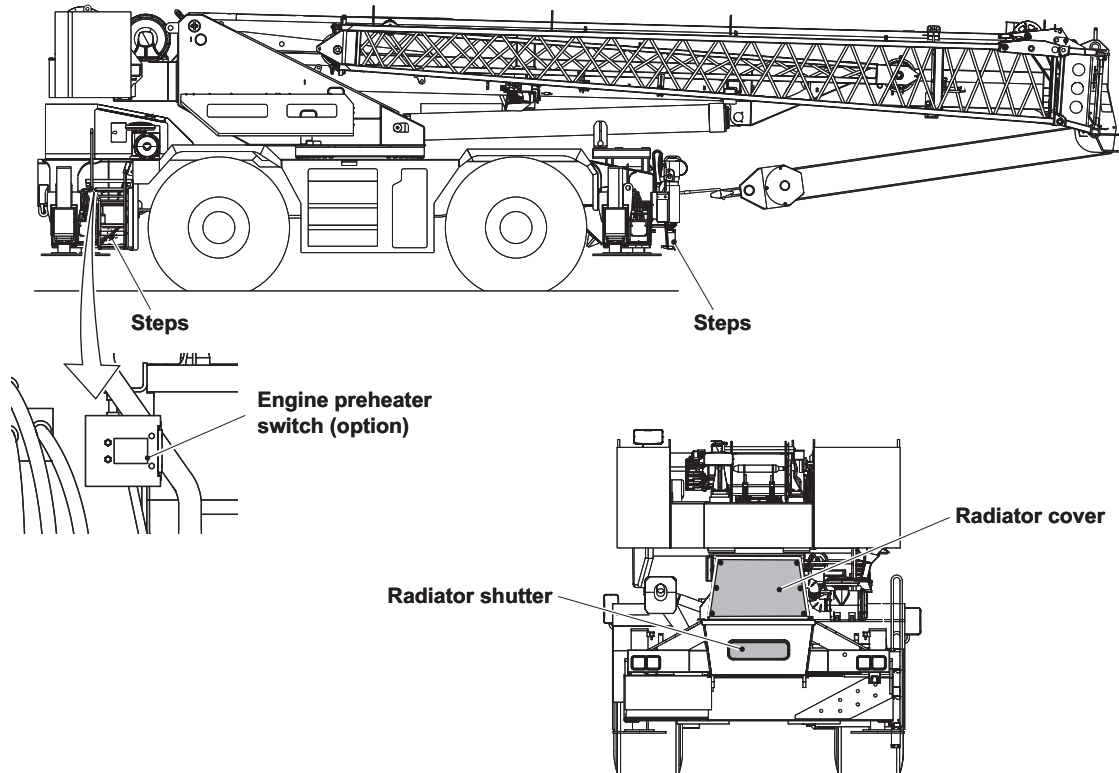

K11447-00E

Steps

⚠ WARNING

- Before traveling, stow the steps in the stowing position and secure it with the stowing pin. If the steps are not fixed in the stowing position, they can swing during traveling and cause an accident.
- When you use the steps, hold the handrails of the steps and be careful not to fall.

Steps (2 locations)

When you extend the steps, remove the stowing pins and lower it by turning the step slowly.

When they are not in use, stow them to the stowing position and make sure to fix it with the fixing pin.

⚠ CAUTION

During crane operation, leave the steps extended.

If you use the steps in the stowed status, this can cause a falling accident or damage to the steps.

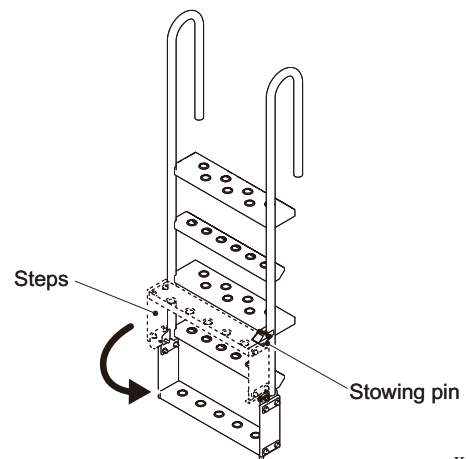

K08786-00E

Outrigger Extending Status and Lifting Performance

When all the outriggers are extended to maximum, the crane's capacity is the same throughout 360 degrees. The rated lifting capacity in the side area changes depending on the extension width of outriggers. When a load is lifted on a side of larger extension width of outriggers and slewed to a side of smaller extension width, the rated lifting capacity decreases. Be careful to avoid overloading.

Rated lifting capacities in front and rear areas are the same as the outrigger maximum extension capacity. Depending on the extension width of outriggers, the ranges of front and rear areas are decreased as shown in the diagrams below.

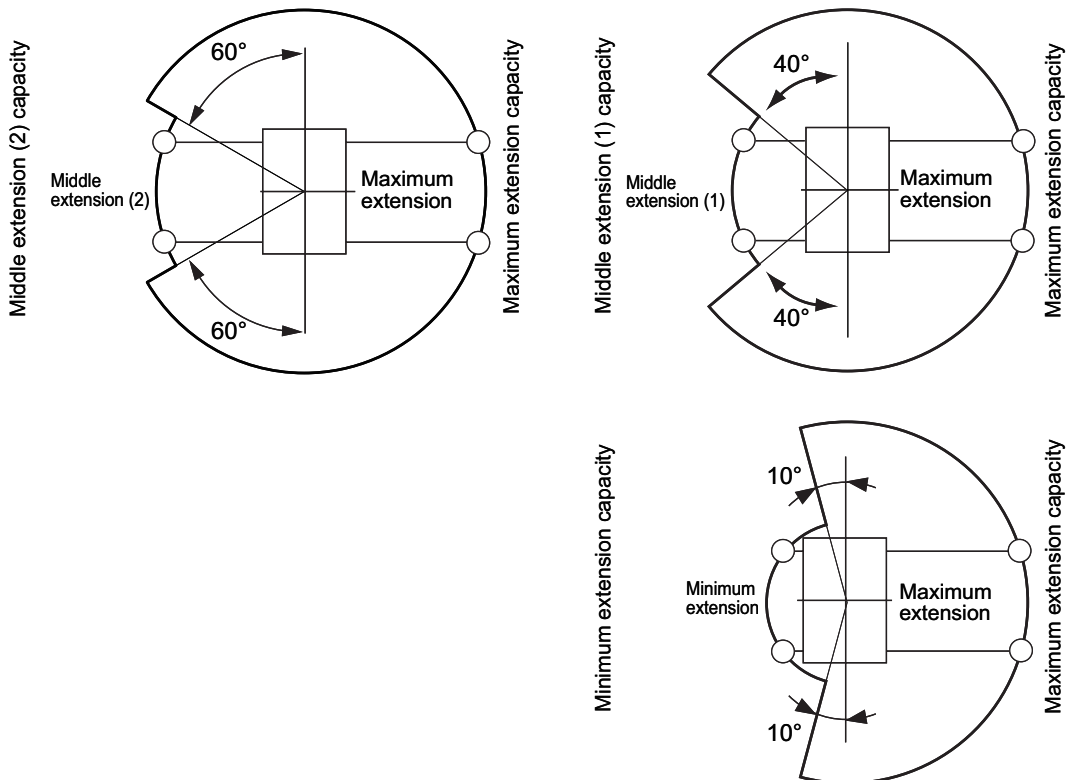

K02694-00E

 For details refer to the section "Extension Width of Outriggers and Working Area" (page 451).

(17) ECO mode indicator

Lights up when ECO mode switch is on and displays current mode such as ECO mode 1 or ECO mode 2.
AML

 To cancel the registration, press the cancel key. The pop-up window closes and the AML returns to the state before start of the registration.

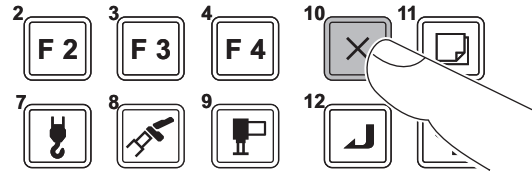

K00680-000

- 8.** Press the set key.
- When the boom is fully retracted, the pop-up window for boom telescoping mode selection appears on the display panel.

 When the boom is extended, the boom telescoping mode cannot be selected.

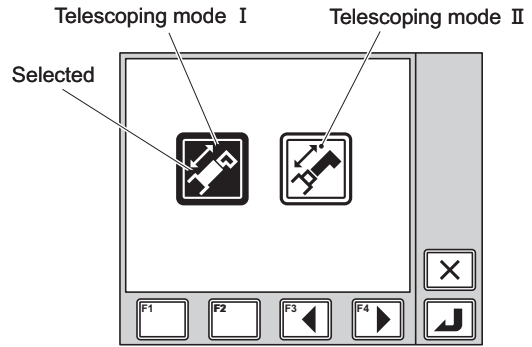

K01838-01E

- 9.** Press the F3 (Backward) or F4 (Forward) key to select one of the telescoping mode icons.
- The selected icon is highlighted.

- 10.** Press the set key to register the setting.
- After registration is completed, the pop-up window closes and the AML returns to the crane operation state.

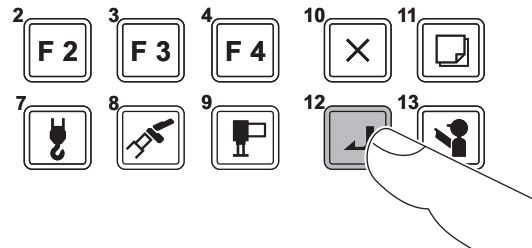

K00678-000

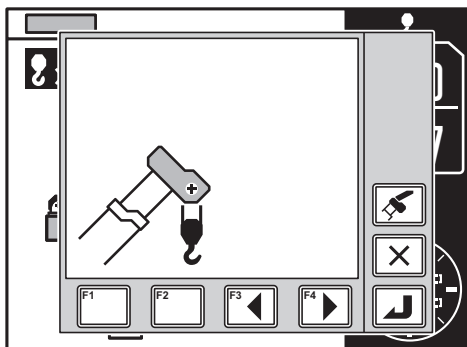

Lift status indication symbol represents the registered status.

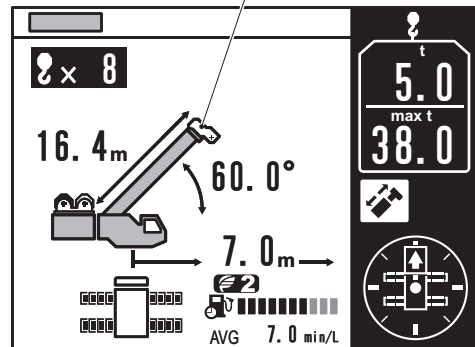

K04317-01E

[Error code] "Message"	Buzzer	Cause	Remedy
[W0271] "Boom not fully retract"	AML built-in buzzer: beep-beep-beep (Every 1 second for 5 seconds) Alarm buzzer: Intermittent sound (Every 0.4 seconds)	All conditions below have occurred at the same time. • Jib set status or jib lift status is registered to the AML. • Boom is not fully retracted. • The boom angle is close to horizontal.	Before mounting/stowing the jib, fully retract the boom.
[W0282] "Jack reaction force lower limit"	AML built-in buzzer: beep-beep-beep (Every 2 seconds)	The min. value of the outrigger jack supporting pressure is below the lower limit warning value.	Check the outrigger status symbol on the AML, and change the crane operation status so that each jack supporting pressure value becomes the middle of the maximum and minimum values.
[W0283] "Jack reaction force upper limit"		The max. value of the outrigger jack supporting pressure is over the upper limit warning value.	
[W0287] "Out of level"		The inclination angle of the slewing table has exceeded the specified limit.	Stop the crane operation and check the installation ground.

(5) Preset Menu

⚠ CAUTION

**Do not operate the preset menu during a crane operation.
Distraction can cause a serious accident.**

The functions below are available as the preset menu.

- ECO mode selection
- Activating/deactivating winch drum rotation buzzer
- Fuel consumption history display
- Selection of winch to be used
- Setting of anemometer alarm threshold value (option)
- Adjustment of display panel contrast
- Transmission of telematics data

Preset Menu

1. Press the preset menu key.
 - The pop-up window for the preset menu selection appears on the display panel.

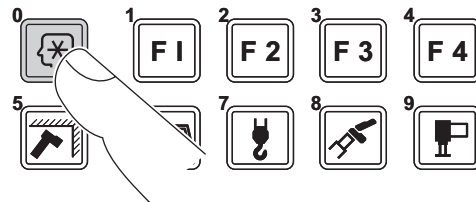

K00702-000

Adjustment of Display Panel Contrast

1. Select the contrast adjustment menu icon, and press the set key.
 - The pop-up window for contrast adjustment appears on the display panel.

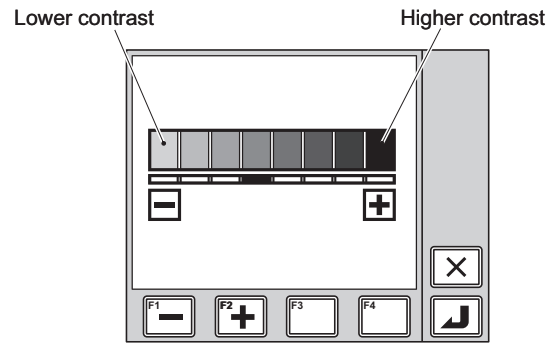

K00711-00E

2. Press the F1 (-) key or F2 (+) key to adjust the contrast.
 - Press the F2 (+) key to increase contrast and the F1 (-) key to decrease contrast.
3. Press the set key.
 - When registration is completed, the pop-up window closes and the AML returns to the crane operation state.

 To cancel the registration, press the cancel key. The pop-up window closes and the AML returns to the crane operation state without changing registration.

 If you press the cancel key for 3 seconds or more, the contrast returns to the initial setting.

 Even after the AML is turned off, the registered information is retained. When the AML is turned on, the operation starts with the retained information.

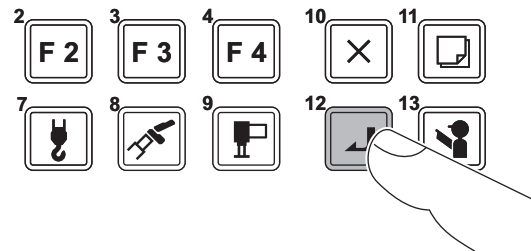

K00678-000

Anemometer (Option)

⚠ WARNING

A strong wind sways the lifted load. This is dangerous to workers and surrounding structures, and can damage the boom and overturn the machine. Note that the longer the boom is, and the larger the area of the load is, the more the wind affects the machine. The rated lifting capacity does not include the effect of the wind on the load, boom or jib. If you find it difficult to control the load because of the wind, stop crane operation. During boom lift, when the wind speed is between 9 m/s and 12 m/s, reduce the rated lifting capacity by 50%, and when the wind speed is between 12 m/s and 14 m/s, reduce it by 70%. Stop operation when the wind speed exceeds 14 m/s. During jib lift, stop operation when the wind speed is 9 m/s or more.

NOTICE

If the display of the wind speed on the AML is not correct, check the connections of the electric cables.

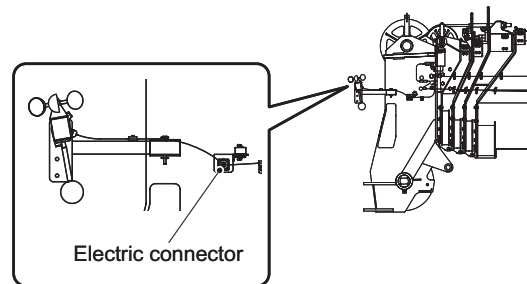

K10453-00E

In some cases, the ground that seems to be rigid enough cannot support the machine, depending on the internal condition of the ground. Be careful when you set up the machine on the ground listed below.

- Road surfaces paved with blacktop
- Stone-paved road surfaces such as a sidewalk
- Backfilled site after excavating work
- Reclaimed land
- Shoulder of a road or periphery of an excavated hole

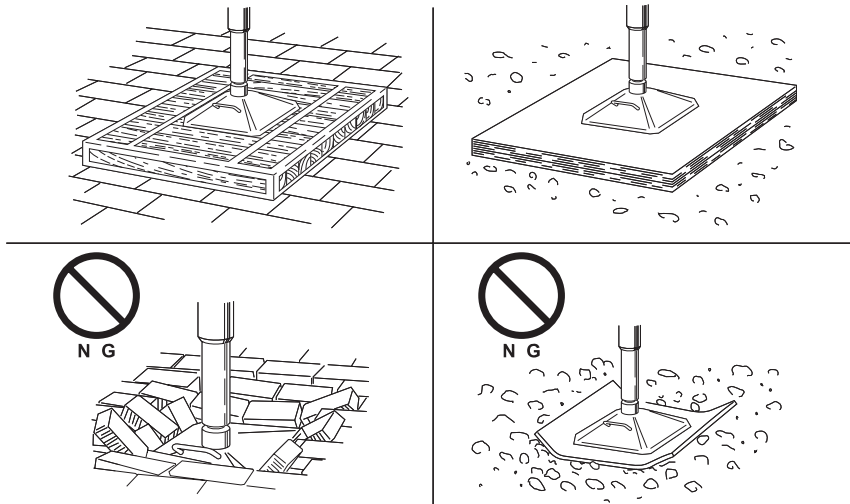

G37004-00E

Hoisting

Boom telescoping/auxiliary winch control selector switch
Selects the control mode (telescoping or auxiliary winch) for the boom telescoping/auxiliary winch control lever.

Boom telescoping/auxiliary winch control lever

Main winch high-speed hoist up/down switch

Auxiliary winch high-speed hoist up/down switch

Drum indicator

Auxiliary winch control icon

Displayed when the boom telescoping/auxiliary winch control selector switch is set to "auxiliary winch".

Main winch control lever

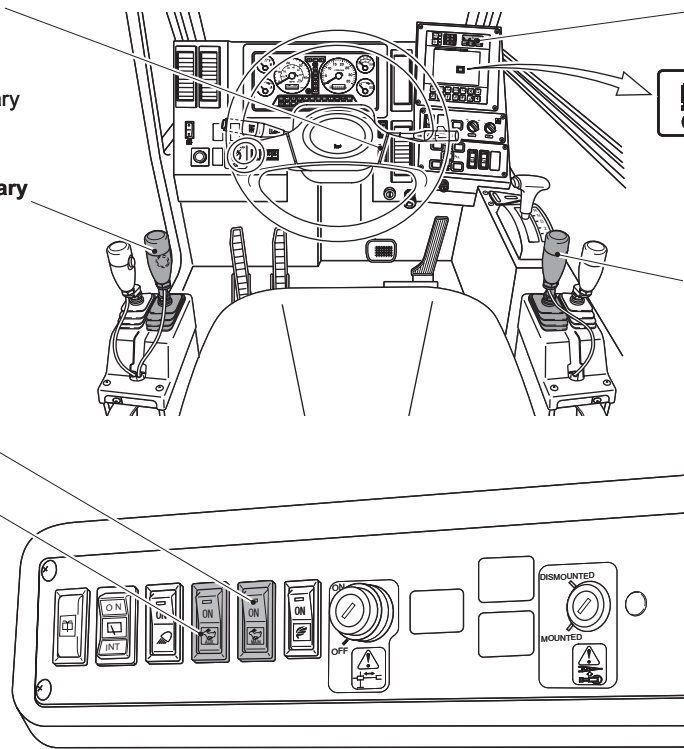

K11465-00E

CLICK HERE TO **DOWNLOAD** THE COMPLETE MANUAL

- Thank you very much for reading the preview of the manual.
- You can download the complete manual from: www.heydownloads.com by clicking the link below



- Please note: If there is no response to CLICKING the link, please download this PDF first and then click on it.

CLICK HERE TO **DOWNLOAD** THE COMPLETE MANUAL

Boom Telescoping Mode II (3rd/4th/Top Boom Sections Extend First.)

1. Push the "boom telescoping" side of the boom telescoping/auxiliary winch control selector switch.

- The boom telescoping control icon is highlighted.

 Push down and hold the lock knob, and push the "boom telescoping" switch.

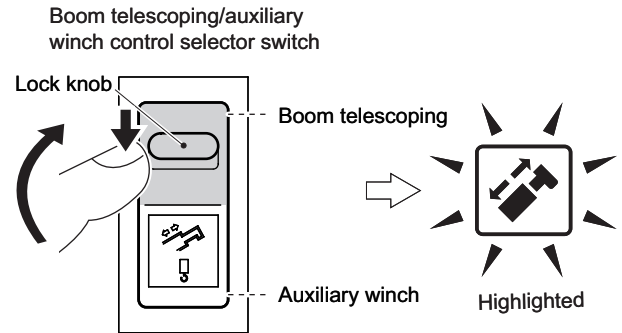

K10534-00E

2. In the pop-up window for AML operation state registration, select "Telescoping mode II". For the boom telescoping mode registration, refer to "Registration of Operating Status and AML Function Check" (page 145).

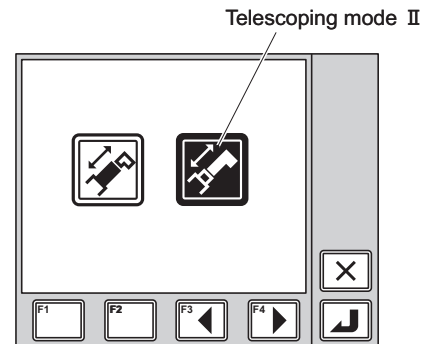

K01416-00E

3. Push the boom telescoping/auxiliary winch control lever forward, and fully extend the 3rd, 4th and top boom sections.
4. While pushing the lever forward, push the head/end boom extension switch.
 - The 2nd boom section extends.

 Once the 2nd boom section starts extending, the extension continues even if the head/end boom extension switch is released.

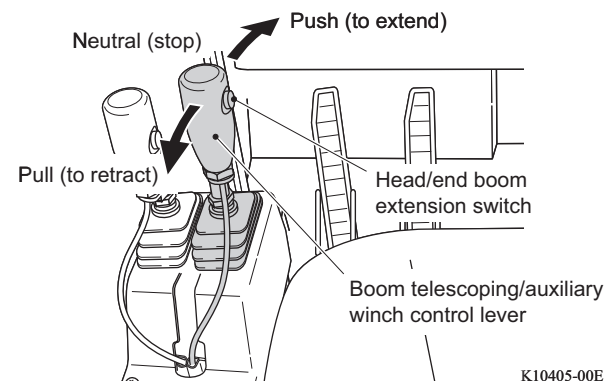

K10405-00E

5. When the boom has extended to a necessary length, pull back the lever to the neutral position.

On-rubber Creep Operation

⚠ WARNING

- Observe the following in order to prevent the machine from overturning or being damaged.
- For safety, keep the lifted load close to the ground, and support it with an auxiliary rope, etc. to restrain the swaying of the load during traveling.
 - Keep the PTO switch "ON" so that the crane can be immediately operated during creeping in order to prevent danger.
 - Never operate the crane during on-rubber creep operation with a load lifted. Stop traveling before operating the crane.
 - Travel at a speed of 1.6 km/h or less (very slow speed), and restrict the moving distance to 60 m or less per 30 minutes.
 - Avoid rough operations such as sudden start/stop, abrupt steering, etc. Such actions cause the load to sway.

1. Direct the boom toward the over-front.
2. Register the on-rubber creep operation to the AML.

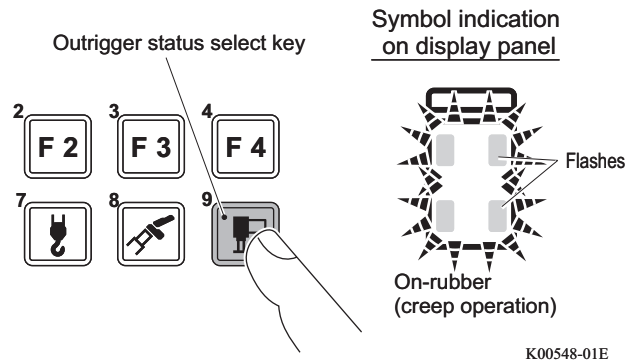

3. Register the lift status (single top/boom) to the AML.

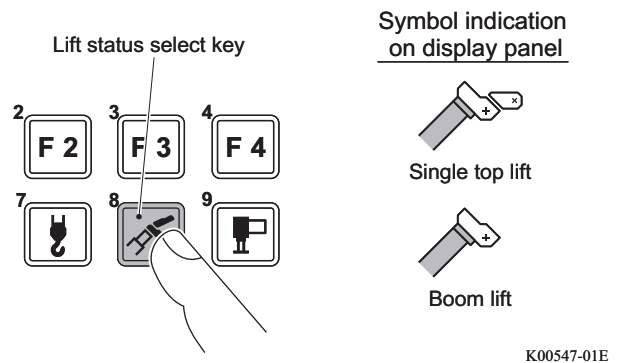

4. Lift a load.

9. Mount the rope socket as shown in the illustration.

⚠ WARNING

Securely tighten the fixing pin mounting bolt for the rope socket using a wrench. After attaching the fixing pin, secure it using a split pin so that the fixing pin does not come out. Improper installation can cause the rope socket to come off and the lifted load to fall, resulting in an accident.

☞ Install the rope socket to the right or left side of the boom according to the "Standard Number of Parts of Line" (page 234).

To attach the rope socket to the right of the boom

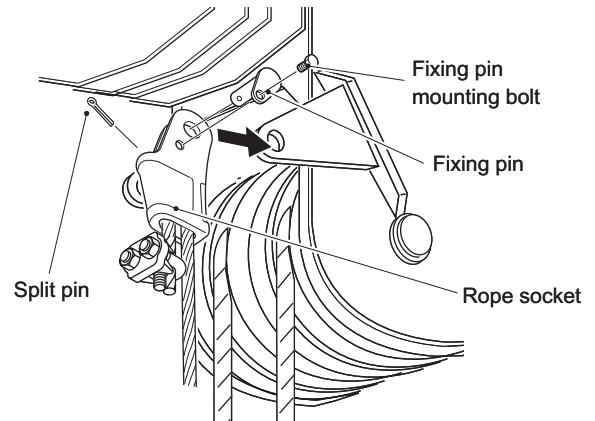

To attach the rope socket to the left of the boom

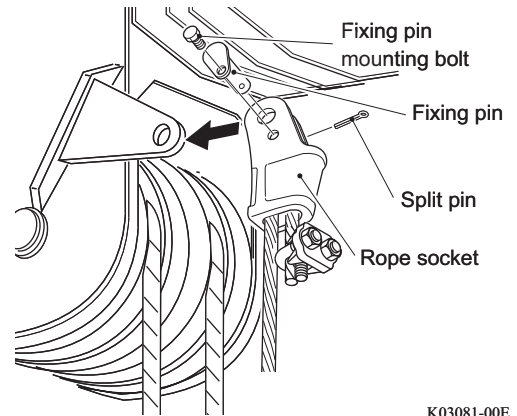

K03081-00E

4. Connect and disconnect the wiring for the anti-two-block device as shown in the illustration. Attach the cap to the removed connector for the anti-two-block device and stow it into the stowing position. Attach the dummy plug to the plug where the connector for anti-two-block device has been connected.

NOTICE

To disconnect the wiring, pull the connector itself, and never pull on the cord.
The cord can be broken.

 Connect the connectors securely. Otherwise the machine movement stops and an error code is displayed on the AML.

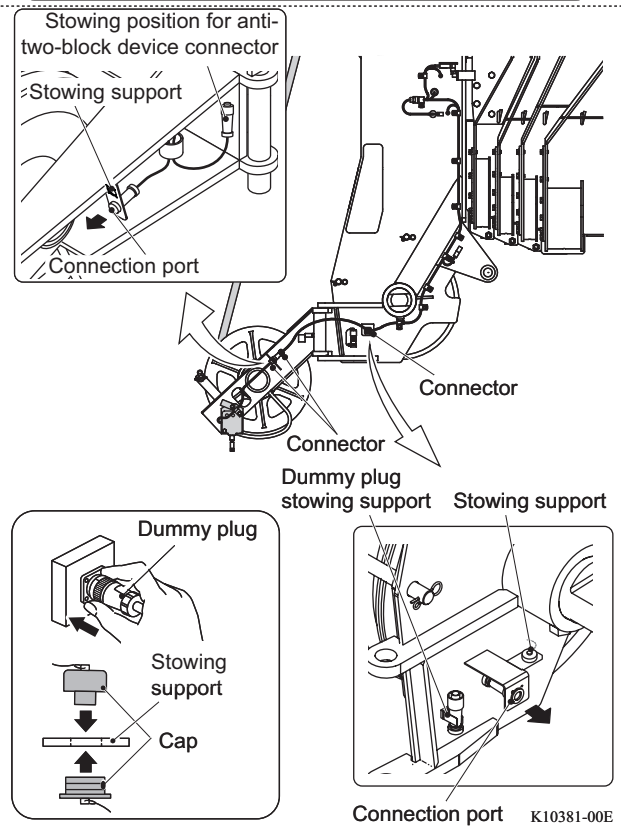
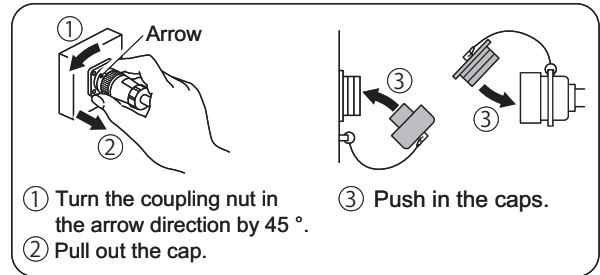
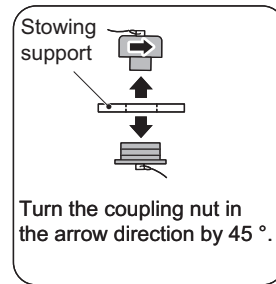

5. Remove the anti-two-block device.

Mounting of Base Jib

WARNING

- Do not enter the area under and in front of the jib during jib mounting. The jib can move unexpectedly and cause a serious injury.
- When you work on the slewing frame, wear a safety belt to prevent a falling accident. Falling from the slewing frame can result in a serious injury.
- Securely mount the jib. If it is not securely mounted, it can cause a serious injury.
- Do not operate the crane while the stowing pin and pivot pin are pulled out from the base jib. The jib can fall and cause a serious accident.

NOTICE

- Before mounting the jib, be sure to retract the boom fully. Otherwise, the boom can be damaged.
- If the anemometer (option) is attached to the boom head, remove it. If the jib is mounted without removing it, the machine can be damaged.

1. Fully extend the outriggers and set up the crane horizontally in a place where sufficient space is available for jib installation.
2. Take out the auxiliary hook block from the stowing position, and place it approx. 20.2 m away from the slewing center.

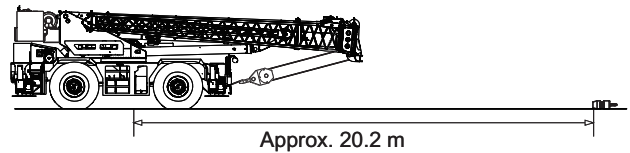

K06300-00E

3. Register the jib set state to the AML.
 - The jib state indicator symbol flashes.

NOTICE

When the jib set state is registered to the AML, the automatic stop function does not activate even if the hook block is overwound.

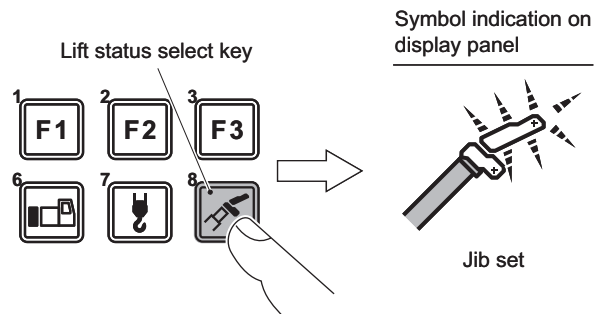

K02043-01E

Mounting of Base Jib + Top Jib

⚠ WARNING

For basic precautions, refer to the previous section "Mounting of Base Jib."
Observe the precautions in the section "Mounting of Base Jib" during operation.

NOTICE

- Be sure to mount the base jib before mounting the top jib.
Incorrect mounting practice can damage the boom.
Mount the jib according to the set procedure.
- If the anemometer (option) is attached to the boom head, remove it.
If the jib is mounted without removing it, the machine can be damaged.

1. Fully extend the outriggers and set up the crane horizontally in a place where sufficient space is available for jib installation.
2. Take out the auxiliary hook block from the stowing position, and place it approx. 27.8 m away from the slewing center.
3. After completing the Steps 3 to 7 of the chapter "Mounting of Base Jib", attach a guide rope to the head of the base jib.

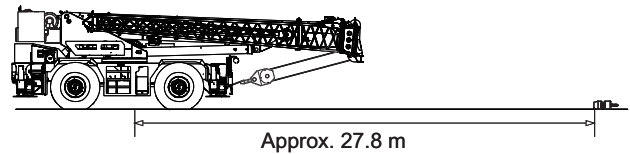

K06301-00E

Changing Jib Offset Angle

⚠ WARNING

- Do not enter the area under the jib while changing the jib offset angle. Unexpected movement of the jib can cause a serious injury.
- When you work at an elevated place, use a platform to prevent a falling accident. Falling from an elevated place can result in a serious injury.

NOTICE

- Be sure to change the jib offset angle with the boom fully retracted.
- If the offset angle is changed while the boom is extended, the boom can be damaged.
- When the jib offset angle is increased, the load radius increases as well. When you increase the offset angle, pay attention so that an overload does not occur.

1. Fully retract the boom, and lower the boom so that the head of the jib comes near the ground.
2. Register the jib set state to the AML.
 - The jib state indicator symbol flashes.

NOTICE

When the jib set state is registered to the AML, the automatic stop function does not activate even if the hook block is overwound.

Lift status select key

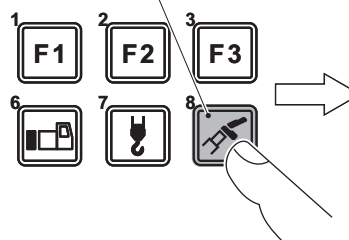

Symbol indication on display panel

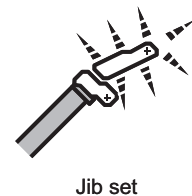

K02043-01E

3. Remove the auxiliary hook block, and mount the rope socket to the bracket on the jib with the fixing pin.

NOTICE

Mount the rope socket always as shown in the illustration. If mounted upside down, the rope socket contacts the lower surface of the jib and can be damaged when the wire rope is tensioned.

Base jib

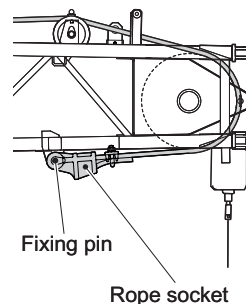

Base jib with top jib mounted

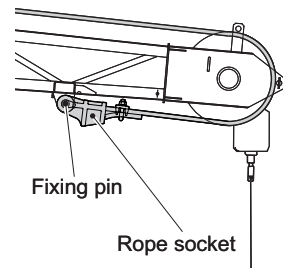

K02078-00E

- 20.** Draw the base jib toward the boom side until the base jib and top jib are connected with the set pin (E).

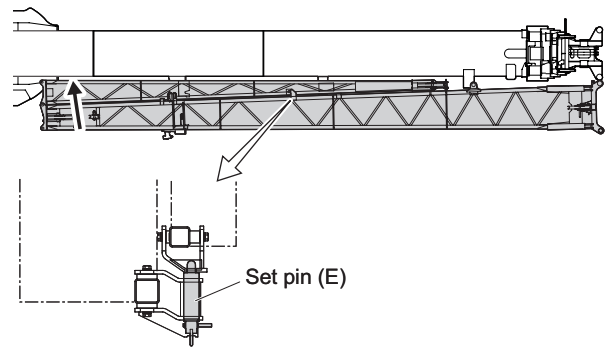

K02100-00E

- 21.** Insert the stowing pin (A) for the base jib, and secure it with the snap pin.

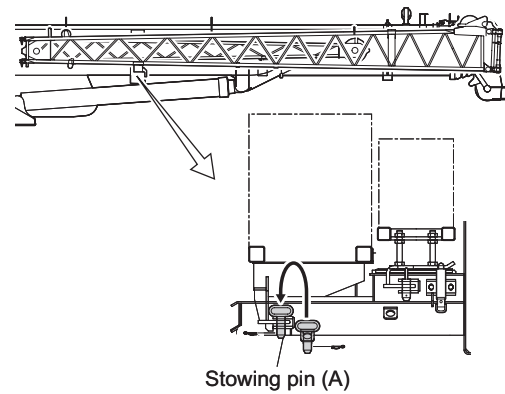

K02101-00E

- 22.** Insert the connecting pins (I) and secure them with the snap pins to connect the base jib and top jib.

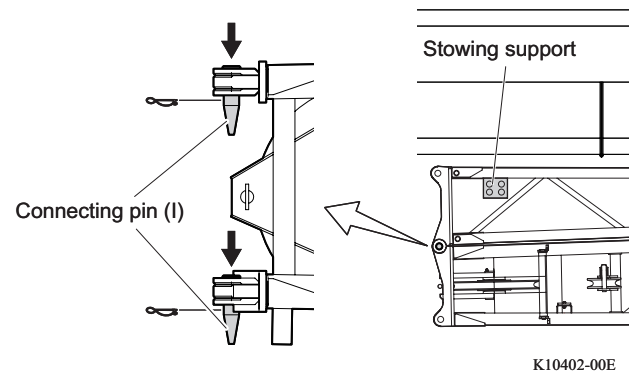

K10402-00E

5. Dismount the jib from the crane body.
6. Set the jib status switch to "DISMOUNTED".
 - The jib dismount icon highlights on the AML.

⚠ WARNING

If the switch position does not correspond to the actual jib mounting status, the calculation base of the AML is incorrect, and the machine can overturn or be damaged.

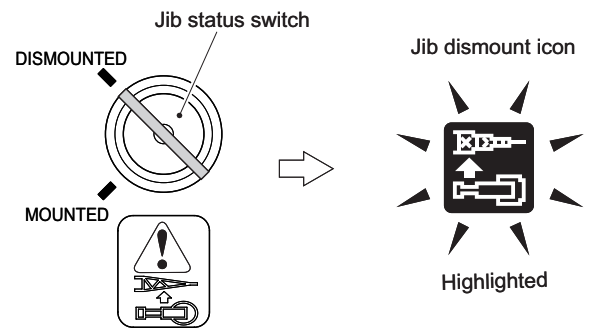

K10429-00E

• Stop Engine during Inspection and Maintenance

If you touch or come near to a rotating part of an engine while it is running, your hands or clothing can be caught, resulting in an injury. Be sure to stop the engine before inspecting the machine.

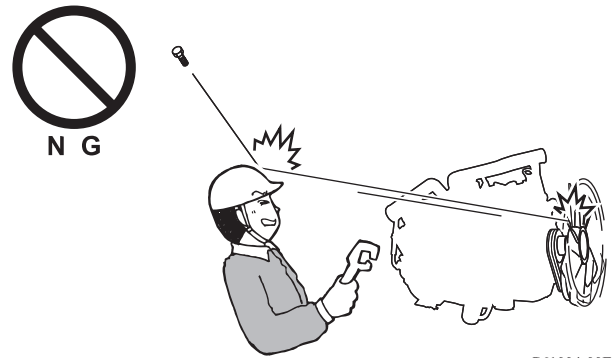

G61004-00E

• Keep Away from Moving Parts

If someone operates the machine unawares of the ongoing inspection, or if you touch a moving part, you can be caught by the machine. It is extremely dangerous. If inspection and maintenance must be performed with the machine operated, keep away from the movable parts such as the boom, boom elevating cylinder, winch, fan, fan belt, propeller shaft, etc. In addition, allow no one to gain access to these parts. When you have to work near movable parts, be extremely careful so that your hands or clothing do not touch the movable parts.



G61005-00E

• Wash Machine before Inspection and Maintenance

If the machine is soiled, it is difficult to find a faulty part, and the dirt enters the machine easily during inspection and maintenance. In addition, dust or mud can get into your eyes, or your feet can slip, resulting in an injury. Before inspection and maintenance, wash the machine.

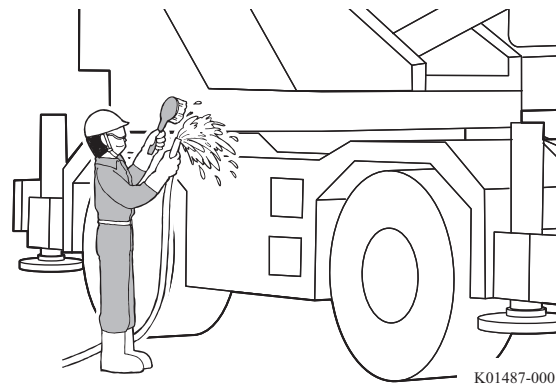

K01487-000

• Precautions for Washing Machine

If water is sprayed on the area where high-pressure washing is prohibited, it can cause a short circuit and a failure. Do not spray water on the area where high-pressure washing is prohibited.

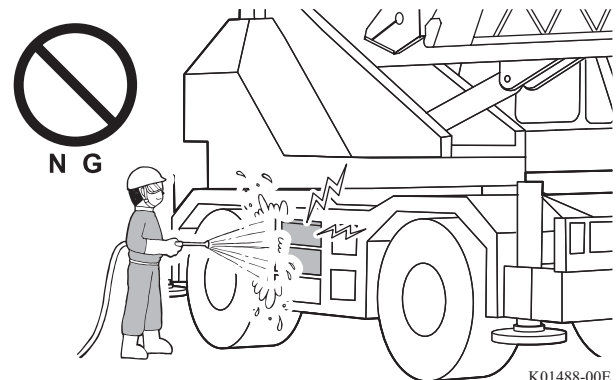

K01488-00E

Important periodic replacement parts (Oil, filter)		Replacement interval (required)	First replacement
Steering system	Steering filter element	1 year or 1,200 hours	
Brake system	Brake fluid	1 year or 1,200 hours	
Powertrain system	Transmission oil	1 year or 1,200 hours	1 month (100 hours)
	Transmission filter element		
	Differential oil	2 years or 2,400 hours	
	Axle wheel hub planetary gear oil		
Engine	Engine oil	250 hours	
	Oil filter element	500 hours	
	Air cleaner element	1 year or 1,200 hours	
	Fuel filter	500 hours	
	Long life coolant	2 years or 2,400 hours	
Slewing system	Gear oil for reducer	1 year or 1,200 hours	
Hydraulic oil tank	Oil	4 years or 4,800 hours	
	Oil filter	1 year or 1,200 hours	
	Air breather cap	6 months or 600 hours	
	Line filter	2 years or 2,400 hours	

Inspection and maintenance item		Inspection and maintenance interval			Remarks	
		Daily inspection	Every month or earlier	Every year or earlier		
Components	Inspection item					
Boom telescoping/elevating system	Boom	Mounting, crack, deformation, damage	○	○	○	(*1)
		Wear on pad, lubrication, wear on pivot		○	○	
		Damage, wear, breakage, deformation, abnormal noise of boom structure		◇		
		Welded structural parts		◇		
		Important structure mounting parts (pin, bolt, etc.)		◇		
	Single top (including boom head)	Mounting, crack, deformation, damage	○	○	○	
		Wear, lubrication		○	○	
	Telescoping cylinder (including holding valve)	Mounting, operation, looseness, oil leakage, spontaneous retraction	○	○	○	
	Boom elevating cylinder (including holding valve)	Mounting, operation, looseness, oil leakage, spontaneous retraction	○	○	○	
		Wear on pivot pin, lubrication		○	○	
Telescoping wire rope	Telescoping, synchronization, wear, damage, corrosion, cut wire		○	○	(*2)	
Sheave	Mounting, operation, deformation, damage, wear		○	○		
Telescoping hose in boom	Mounting, elongation, crack, damage, deterioration		○	○	(*2)	
Jib system	Jib	Mounting, crack, deformation, damage	○	○	○	
		Installing and stowing status, lubrication, wear on pivot		○	○	
		Damage, wear, breakage, deformation, abnormal noise on jib structural parts		◇		
		Welded structural parts		◇		
	Important structure mounting parts (pin, bolt, etc.)		◇			
Sheave	Mounting, operation, deformation, damage, wear		○	○		
Winch	Winch drive unit, winch drum	Mounting, operation, crack, oil leakage, damage, abnormal noise	○	○	○	
		Looseness, soiling, oil level, wire rope winding status, wire rope mounting, looseness in drum bearing		○	○	
	Winch brake	Oil leakage	○	○	○	
		Operation, brake performance		○	○	
	Wire rope	Mounting status of rope socket, disorderly winding, wear, damage, condition of places where wire ropes pass through	○	○	○	
		Corrosion, deformation, cut wire, entangling, lubrication	○	○	○	
Piping, hose	Mounting, looseness, crack, oil leakage, damage, deterioration		○	○		

Tire Condition

⚠ WARNING

**Check the tire air pressure before traveling when the tires are cold.
If the pressure is too high or low, the tires can be damaged or an accident can occur**

Tire Air Pressure

1. Check the tire air pressure with an air gauge.
2. If the air pressure is not correct, adjust it to the specified pressure.
3. After measuring the pressure and inflating the tire, attach the valve cap.

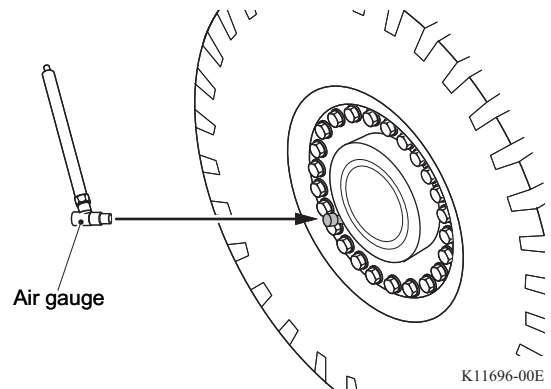

Looseness of Wheel Nut, Crack on Wheel

⚠ WARNING

If any abnormality is found, do not travel. A serious accident can occur.

1. While putting your fingers on the lower side of the wheel nut, knock the upper side of the wheel nut lightly in the direction where the wheel nut is tightened.
2. Check for the difference of vibrations felt by the fingers between the wheel nuts. Also, check for the occurrence of an abnormal sound.
3. If any abnormality is found, do not travel. Contact a TADANO distributor or dealer.

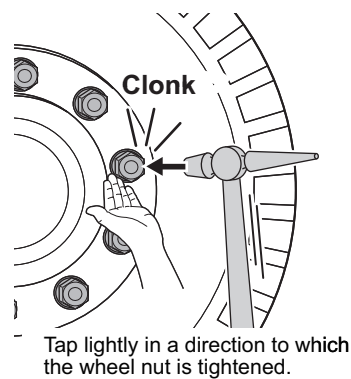

Function of Parking Brake

⚠ CAUTION

Inspect the parking brake on a level ground with the brake pedal depressed.

Start the engine, and inspect when the air is at the specified pressure.

Inspect that the exhaust sounds (air evacuating sound) can be heard for the parking brake operation when the parking brake switch is set to "PARK".

- The brake warning lights up.

If any abnormality is found, contact a TADANO distributor or dealer for inspection and maintenance.

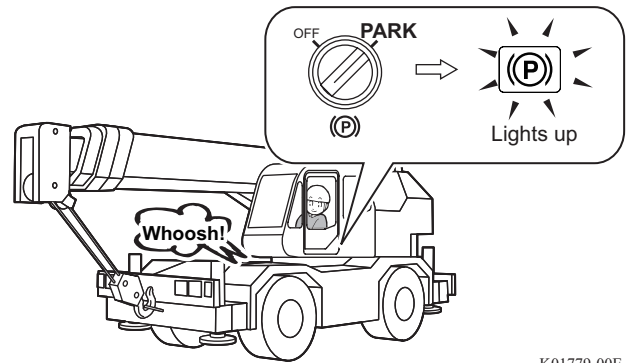

K01779-00E

Check of Wire Ropes, Sheaves, and Guides

1. Check for any crack, wear, deformation of the rope end, and damage to the rope terminals.

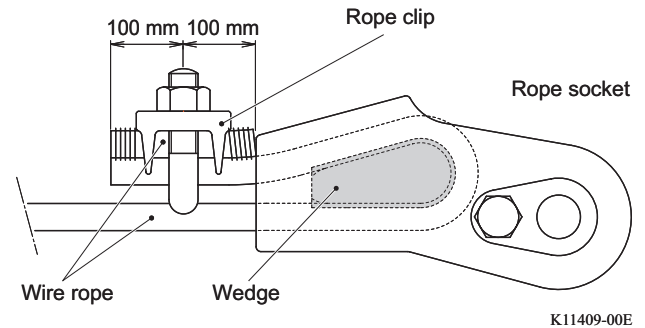

2. Check that the wire rope is not wound up disorderly on the winch drum.

If it is wound up disorderly, rewind it.

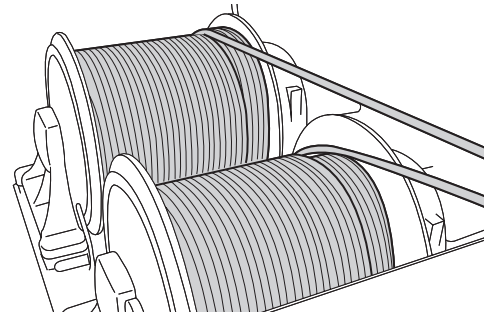

The wire rope is correctly wound on the winch drum

3. Check the wire rope for wear, damage of outer layer and inner layer, breakage, reduction in outside diameter, and drying conditions.

If any abnormality is found, replace the wire rope.

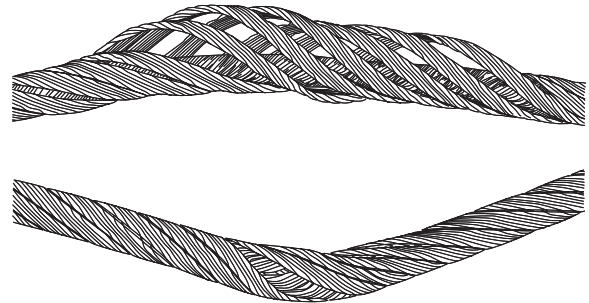

4. Extend the outriggers, and set up the machine horizontally.

5. Raise the boom to approximately 45°, and check that the wire rope correctly passes through the sheaves and guides.

If the wire rope is out of track of the sheaves and guides, pass the wire rope through the sheaves and guides.

If any abnormality is found, contact a TADANO distributor or dealer for inspection and maintenance.

Slide Plate (Upper Surface of Boom) (Fig. 1)

1. Fully extend the outriggers, and set up the crane horizontally.
2. Fully retract the boom, and lower it to the horizontal position.
3. Apply grease.

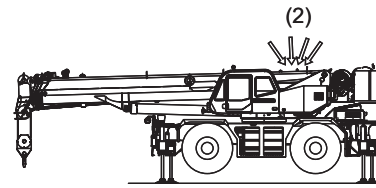

Fig.1

K05464-00E

Sides and Lower sides of Boom, Wire Ropes (for boom telescoping) (Fig. 2,3)

1. Fully extend the outriggers, and set up the crane horizontally.
2. Fully retract the boom, and lower it to the horizontal position.
3. Fully extend the 2nd boom section in Boom telescoping mode I, and then supply grease to the points shown in Fig. 2.
4. Completely retract the Boom.
5. Fully extend the 3rd, 4th and top boom sections in Boom telescoping mode II, and then supply grease to the points shown in Fig. 3.

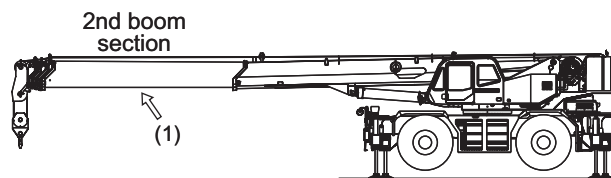

Fig.2

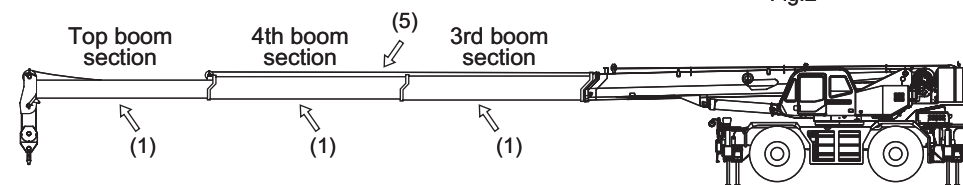

Fig.3

K05465-01E

Engine Cooling System

⚠ WARNING

- The coolant is very hot immediately after operation. If you open the radiator cap while the coolant is hot, the hot coolant can spout out and you can suffer burns. Let the coolant cool down before you start the work.
- When you handle long-life coolant (LLC), keep in mind the following:
 - LLC is poisonous. Do not ingest. If someone accidentally ingest it, immediately try to make the person vomit and seek medical attention. If the LLC gets in your eye, immediately flush it out with clean water and seek medical attention.
 - Keep the LLC away from fire. LLC is flammable.

NOTICE

- To prepare coolant mixture, use soft water.
Do not use water from wells or rivers.
- When you add the coolant, do not change the mixture ratio of the long-life coolant (LLC). Add coolant that has the same mixture ratio. Do not mix the LLC of different brands. If you must use different brand of LLC, drain all the remaining coolant before you add new coolant.
- Mix the long life coolant (LLC) with water in a 30:70 ratio.
- Keep the air conditioner turned on when you replace the coolant. The coolant in the air conditioner system is replaced only while the air conditioner is in operation.

Maintenance Table

No.	Item		Points/Quantity	Inspection and maintenance interval					
				60 h	100 h	300 h	600 h	1200 h	2000 h
					1 month	3 months	6 months	1 year	2 years
1	Coolant	Replace (Use long-life coolant.)	Approx. 30.3 L (*1)						●
2	Coolant filter	Element cleaning	1 point					●	

(*1): 13 L in engine, 8.8 L in radiator, 8.5 L in connecting hoses etc.,

 For coolant replacement procedures, refer to the separate engine manual.

 For brands of long-life coolant, refer to "Oils and Greases" (page 443).

Brake System

⚠ WARNING

- Do not use different brands of brake fluid together. Use different brands of brake fluid together can change the properties of the fluid and may have an adverse effect on the brake system and it may cause an accident. For brake fluid, use "TADANO" Genuine Brake Fluid".
- "TADANO Genuine Brake Fluid" is glycol-based. If a silicon- or mineral-based brake fluid is used, it will permeate the packings and cause the brakes to become ineffective, resulting in an accident. Always use "TADANO Genuine Brake Fluid".

NOTICE

Use unopened new brake fluid only for replenishment or replacement.

Maintenance Table

No.	Item		Points/ Quantity	Inspection and maintenance interval				
				1 week	100 h	300 h	600 h	1200 h
					1 month	3 months	6 months	1 year
1	Brake fluid reservoir	Replace brake fluid	Approx. 1.7 L					●
2	Disc brake pad	Check for wear	6 points			●		
3	Air dryer	Replace desiccating agent	1 point					●
4	Parking brake pad	Clearance adjustment	1 point					●

Brake Fluid Reservoir

⚠ WARNING

The brake fluid has high moisture absorbing properties. Therefore, if you fail to replace of brake fluid for a long time, vapor lock can occur and cause an accident. Replace brake fluid at the specified intervals.

Replacing Brake Fluid

Contact a TADANO distributor or dealer to replace brake fluid.

Hydraulic Oil Tank

NOTICE

You must bleed air remaining on the suction side of the hydraulic pump after the hydraulic oil replacement. Starting the hydraulic pump without bleeding air damages the pump. After replacing the oil, do not attempt to start the pump until the air is bled. For the bleeding procedure, contact a TADANO distributor or dealer.

Replacing Hydraulic oil

When replacing the hydraulic oil, also replace the return filter.

1. Set the machine into the traveling configuration, and set it up on a level ground.
2. Remove the cover from the filler port and use an oil pump to drain the hydraulic oil from the tank into an oil drum or other suitable container.

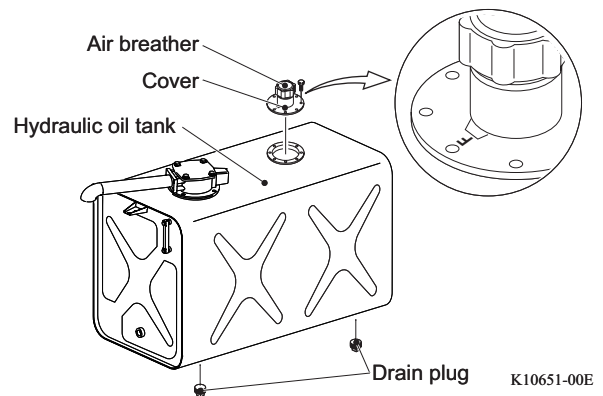

3. Remove the drain plug at the bottom of the tank to release any remaining hydraulic oil.
4. Check the inside of the tank, and clean if any dust or foreign matter is found.
5. Clean the drain plug and wrap a sealing tape around it, then tighten the plug.
6. While watching the oil level in the oil level gauge, add new hydraulic oil into the tank.
7. Remount the cover on the hydraulic oil tank so as the "F" mark on the hydraulic tank cover to face the front of the machine.
8. Bleed the hydraulic oil pump.
9. Check the oil level again. If low, add more hydraulic oil.

Refrigerant Piping Connection

Check

Open the cover on the left side of the machine, and inspect the refrigerant piping connection for seeping oil.

NOTICE

If seeping of oil is significant, the gas can be leaking out of the connection. Contact a TADANO distributor or dealer for inspection and maintenance.

Inside Air Filter

Check, Cleaning

1. Open the inside air filter inspection cover at the rear of the crane operator's seat, and remove the inside air filter.
2. Removing ordinary soiling
Remove the inside air filter, and blow the clean compressed air through it from the side without dust.

Removing severe soiling

Soak and wash the filter in the lukewarm water with mild detergent. Then rinse it with clear water, and air-dry it completely.

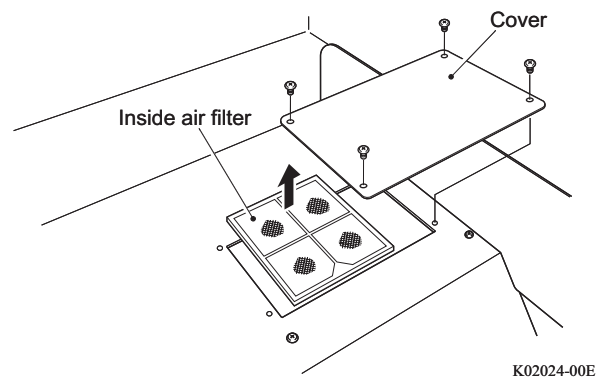

Outside Air Filter

Replacing

1. Open the outside air filter inspection cover at the rear side of the crane operator's seat. Then remove the outside air filter.
2. With attention to the arrow mark on the top of the filter, attach a new filter.

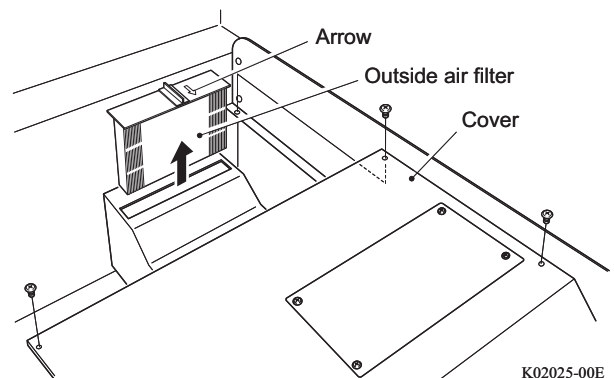

6. Hoist up and down the hook block several times to make the twist even throughout the wire rope. If the tangling still remains after this, do the procedure above again.

NOTICE
If the tangling is severe, correct it step by step several times.

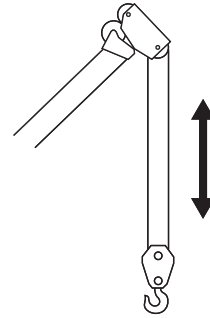

G79015-000

7. Make sure that the wire rope is not wound up disorderly on the winch drum. If the wire rope is wound up disorderly, unwind and wind it again.

Eliminating Excessive Twisting of Wire Rope

NOTICE
If operation is performed in the same configuration for a long time, the wire rope can suffer damage (become untwisted) at the same location, whereby twisting can gather at the rope ends. These causes damage to the wire rope.
To settle a twisting condition of the wire rope, change the number of parts of line, change the operating configuration, or re-reeve the wire rope, reversing the ends (at the rope socket and at the winch drum) of the rope.

- 4.** Set the switch and lever to the positions as shown below.

Shift lever "N"

Drive mode selector "H/2D"

Starter switch "ON"

- 5.** Check that the pointer of the air pressure gauge exceeds the specified value (red mark).

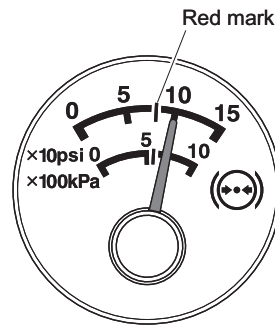

K01342-00E

- 6.** Set the parking brake to "OFF", and start towing of the crane.

Major Specifications

Crane Specifications

Maximum Rated Lifting Capacity

Lift state	Maximum rated lifting capacity	Load radius/angle	Standard number of parts of line
12 m boom	80,000 kg	3.0 m	14
16.4 m boom	46,600 kg	3.0 m	8
20.8 m boom	40,900 kg	3.0 m	Telescoping mode I: 8 Telescoping mode II: 4
29.5 m boom	18,200 kg	5.0 m	4
38.3 m boom	15,100 kg	7.0 m	4
42.6 m boom	11,000 kg	9.0 m	4
47 m boom	9,500 kg	10.0 m	4
10.1 m jib	6,600 kg	80°	1
17.7 m jib	4,000 kg	80°	1
Single top	6,600 kg	-----	1

Lifting Height, Length, Angle, and Speed

Item		Data	
Maximum lifting height	Boom	47.1 m	
	Jib	64.4 m	
Maximum load radius	Boom	40.0 m	
	Jib	46.0 m	
Boom length		12.0 to 47.0 m	
Boom extension speed		35 m / 160 s	
Jib length		10.1 m, 17.7 m	
Hoist-up speed	Main winch	Low speed	107 m/min (4th layer)
		High speed	149 m/min (4th layer)
	Auxiliary winch	Low speed	92 m/min (2nd layer)
		High speed	128 m/min (2nd layer)
Boom angle		-1.5° to 80.5°	
Boom raising speed		20° to 60°/46 s	
Slewing angle		360° continuous	
Slewing speed		1.5 min ⁻¹ {rpm}	

Carrier Specifications

Item	Data
Engine	MITSUBISHI 6M60-TL Model code: 6M604 WTTD0C000
Displacement	7,54 L
Maximum speed	36 km/h

CLICK HERE TO **DOWNLOAD** THE COMPLETE MANUAL

- Thank you very much for reading the preview of the manual.
- You can download the complete manual from: www.heydownloads.com by clicking the link below



- Please note: If there is no response to CLICKING the link, please download this PDF first and then click on it.

CLICK HERE TO **DOWNLOAD** THE COMPLETE MANUAL