

PREFACE

This operator's manual serves as a guide for the use of your SAKAI SW774 Series Vibrating Roller for those who are new to the machine, and also for the people who have experience in using the machine and want to refresh their knowledge for the machine.

Read this manual thoroughly and try to fully understand the information before operating your machine. Keep this handbook at hand whenever you do your work.

When an instruction manual is lost or is damaged and is not legible, replace it immediately.

The main subjects of this manual are:

(1) Basic precautions for safety, (2) Operation, (3) Daily maintenance and (4) Specifications. For operation and maintenance of the engine, refer to the Engine Instruction Manual furnished separately. Descriptions in this manual can differ from the machine instructions of your machine due to the results of the investigation and improvement in its design. If you have any inquiry regarding your machine or this manual, contact our distributors.

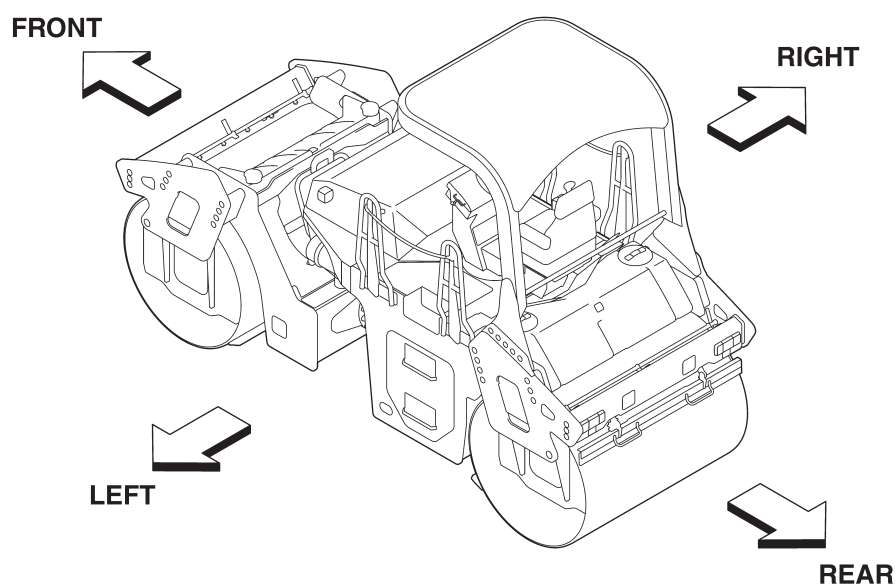

CALIFORNIA

Proposition 65 Warning

Diesel engine exhaust and some of its constituents are known to the State of California to cause cancer, birth defects, and other reproductive harm.

CLICK HERE TO **DOWNLOAD** THE COMPLETE MANUAL

- Thank you very much for reading the preview of the manual.
- You can download the complete manual from: www.heydownloads.com by clicking the link below



- Please note: If there is no response to CLICKING the link, please download this PDF first and then click on it.

CLICK HERE TO **DOWNLOAD** THE COMPLETE MANUAL



⚠ WARNING: Negligence of these instructions can lead to accidents.

1 BASIC PRECAUTIONS FOR SAFETY

■ Be careful with fire

- The fuel, oil, and anti-freeze will catch fire if open flames or ignition sources are used close to them. Particularly, the fuel is highly flammable.
- Do not smoke or use a match or cigarette lighter close to inflammables (combustibles).
- When refueling, stop the engine and do not smoke.
- The filler caps of the fuel and oil tanks must be kept tight.



■ Ensuring safety in a fire

- Machine fires may cause serious injuries or death, so stop the engine by turning the starter switch to the OFF position, then move away from the machine as quickly as possible.

■ While the engine is running or immediately after it has been turned off, do not touch the muffler, exhaust pipe or DPF

- While the engine is running or immediately after it has been turned off, do not touch the muffler, exhaust pipe or DPF, as they will be hot.

■ Mount on or dismount from your machine after it has come to a complete stop

- For getting on and off, face the machine and use the handrail and step.
- Watch your step when getting on or off the machine.
- Do not jump on or off a machine, particularly when it is moving.
- When getting on and off an articulated machine, straighten it out before stopping the machine. In the turned state, there is danger that personnel gets caught because the getting on and off space narrows.

■ Be careful not to fall

- Falling off the machine may cause serious injuries or death, so do not place your feet anywhere other than on the steps, and in the driver's seat.

■ Do not lock out yourself when leaving the machines

- Always bring the key with you by pulling it out from the starting switch when leaving the machine.





⚠ WARNING: Negligence of these instructions can lead to accidents.

1 BASIC PRECAUTIONS FOR SAFETY

1.10 Before Servicing

■ Attach warning tags when servicing the machine

- Serious accidents can occur if the machine is unexpectedly started or controls carelessly touched by an unauthorized person.
- Attach a warning tag at a clearly visible location in the operator's station and insure the key has been removed from the starter switch.



■ Setting the chocks

- Set chocks in front of and behind the roller drum (wheels) to prevent the machine from moving before beginning inspections or maintenance work.

■ Use proper tools

- It is very dangerous to use damaged or deteriorated tools or to use tools for other purposes than intended. Use correct tools for their intended use only.



■ Change safety-related parts at regular intervals

- Change any seatbelt found to be abnormal even if it is within its recommended service interval.
 - Change any ROPS found to be abnormal even if it is within its recommended service interval.
 - Replace fuel hose, high pressure hydraulic hoses and liquid hoses regularly to prevent fire. Replace high pressure hoses of the power steering system every two years.
- ☆ Change these parts at regular intervals even if found to be normal. They will deteriorate as time goes on.
- ☆ Change any hose found to be abnormal even if it is within its recommended service interval.



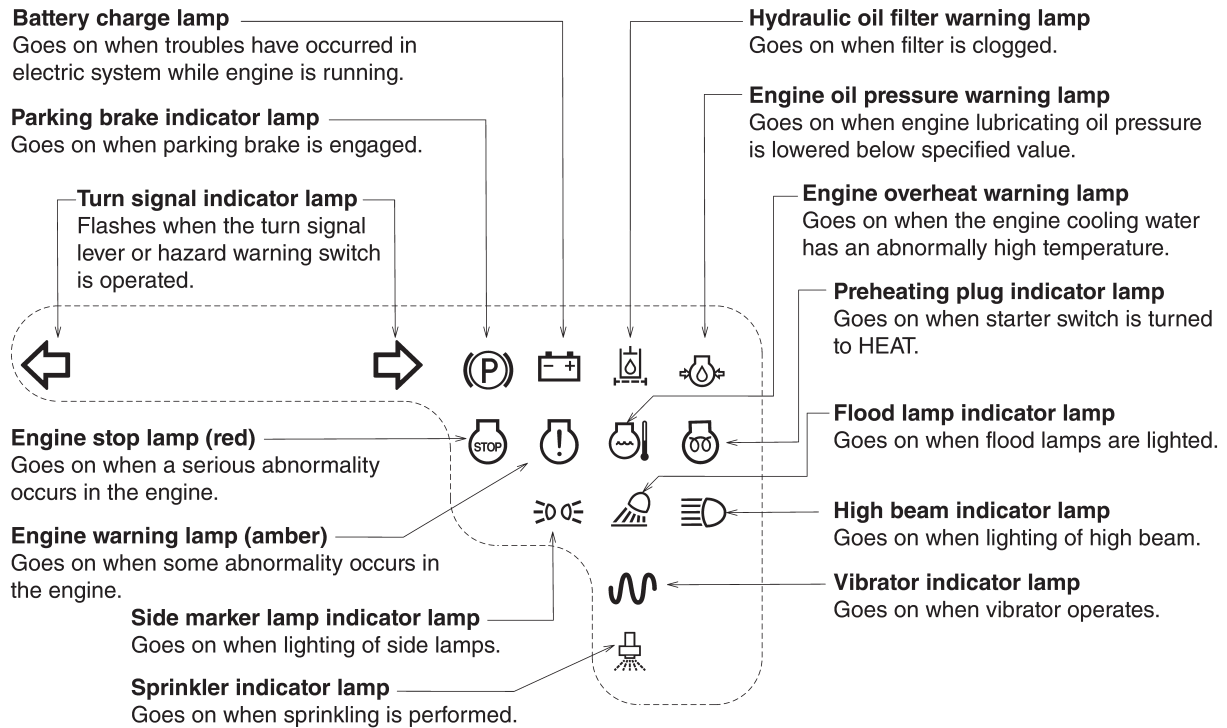

Monitor display



★ Indicator lamps []
Light up when corresponding systems have been operated.

★ Parking brake indicator lamp []
It will flash once when the starter switch is turned to the ON position.
After that it will remain on while the parking brake is engaged, and turn off when it is released.

★ Hydraulic oil filter warning lamp []
It will flash once when the starter switch is turned to the ON position.
After that it will turn on when the hydraulic oil filter becomes clogged. Stop the machine and carry out an inspection.

★ Engine oil pressure warning lamp []
It will turn on when the starter switch is turned to the ON position, and turn off when the engine starts running.
It will turn on while the engine is running if the engine oil pressure drops below the specified value. Stop the machine and carry out an inspection.

★ Battery charge lamp []
It will turn on when the starter switch is turned to the ON position, and turn off when the engine starts running.
It will turn on while the engine is running when a problem arises with the electric system. Stop the machine and carry out an inspection.

Engine diagnostic switch

Engine troubleshooting can be conducted using the trouble code selector switch.

During normal operation, do not operate switches.

Set switch as shown in OFF position during the normal operation.

Refer to 2.2.8 Engine troubleshooting page 48 for detail.

DIAG. position : Engine diagnostic is activated

OFF position : Engine diagnostic is shut off

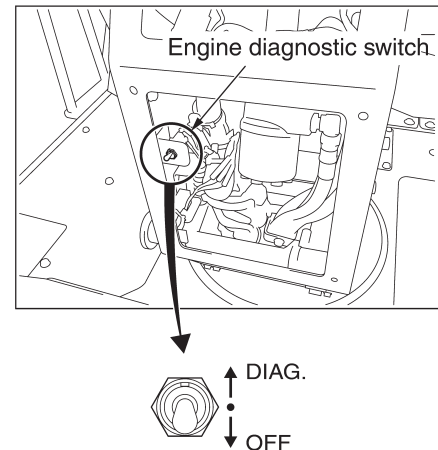

2.1.4 Operating levers and pedals

Forward-Neutral-Reverse (F-N-R) lever with vibrator switch

Moving the F-N-R lever forward or backward makes the machine travel forward or backward respectively. The neutral position brings the machine to a stop. The machine speed increases or decreases in proportion to the lever displacement.

The vibrator ON-OFF control is easily made by the F-N-R lever top vibrator switch (refer to page 33).

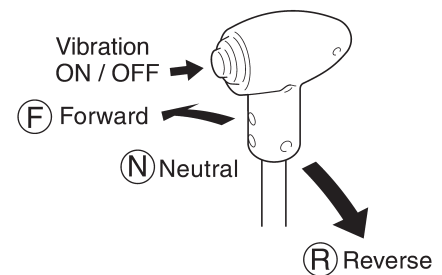
**IMPORTANT**

- For normal braking, return the F-N-R lever back to neutral.
- In an emergency, depress the brake pedal.

Brake pedal

Use it in emergencies. Carry out inspections in accordance with “3.3 Periodical Maintenance Points” (refer to page 80) after each use.

In an emergency, push down on the pedal to the full extent, and the machine will come to a sudden stop.

IMPORTANT

Do not use the pedal wherever practicable except for an emergency. If used during the compacting operation of asphalt pavement, this can cause damage to its surface.

NOTE: Depressing the brake pedal brings the F-N-R lever into neutral (N) .

CLICK HERE TO **DOWNLOAD** THE COMPLETE MANUAL

- Thank you very much for reading the preview of the manual.
- You can download the complete manual from: www.heydownloads.com by clicking the link below



- Please note: If there is no response to CLICKING the link, please download this PDF first and then click on it.

CLICK HERE TO **DOWNLOAD** THE COMPLETE MANUAL

2.3.3 After starting the engine

Try not to move to operation immediately after starting but observe the following:

IMPORTANT

Avoid increasing the engine speed abruptly before warming-up run is completed.

- 1) Run the engine at idling for about 5 minutes to warm it up. Warming-up run allows the lubricating oil to reach the vital parts of the engine and hydraulic system, gradually warm the engine, engine oil and hydraulic oil to prepare the machine for driving.
- 2) After the warm-up operation, check that:
 - Temperature gauge Pointer falls near the center zone
 - Fuel gauge Pointer falls between the E and F marks
 - Battery charge lamp Has gone off
 - Engine oil pressure warning lamp Has gone off
 - Engine stop lamp (red) Has gone off
 - Engine warning lamp (amber) Has gone off
 - Engine overheat warning lamp Has gone off
 - DPF indicator lamp (amber) Has gone off
 - DEF tank low-level lamp (amber) Has gone off
 - DEF quality warning lamp (red) Has gone off
 - SCR-system tampering lamp Has gone off
- 3) Check for the color of exhaust gas, listen for unusual sounds and vibration. If abnormal, determine the cause and correct the problem.

⚠ WARNING

Keep staying at the driver's seat while starting the engine.

2.5.2 DEF SCR system

About the DEF SCR (Selective Catalytic Reduction) system

The DEF SCR system breaks down toxic nitrogen oxides (NOx) contained in the exhaust gas into harmless nitrogen and water. DEF is sprayed into the exhaust gas, and the ammonia generated by the urea reacts with the nitrogen oxides breaking them down into nitrogen and water.

⚠ CAUTION

- **Keep the DEF tank topped up by refilling it at the right time.**
- **Always use the DEF designated by our company.**

⚠ CAUTION

- **The exhaust gas temperature will rise during regeneration, so beware of burns, fires, etc.**
- **The aftertreatment must never be modified. The machine will not be able to function properly, and it will not satisfy exhaust gas emissions standards.**
- **Do not turn the engine off immediately after regeneration.**
Set the Engine speed selector switch in the idling position, and let the engine idle to gradually cool it for around 5 minutes.
- **Stopping the engine suddenly without letting it cool may shorten the life span of engine parts.**
- **Continuing to use the machine without carrying out regeneration when the parked manual regeneration lamp / regeneration lamp is flashing may, in the worst case scenario, result in a limit being placed on the engine output.**
Promptly carry out parked manual regeneration.
- **Parked manual regeneration can be carried out any time, but limit it to once daily except when the parked manual regeneration lamp / regeneration lamp flashes.**
- **Operating the parking brake switch, Engine speed selector switch or F-N-R lever during parked manual regeneration will automatically stop regeneration.**
Restart parked manual regeneration in accordance with the prescribed procedures.

2.10.1 Use of a trailer equipped with a winch

⚠ WARNING

Placing the unloader in UNLOAD position disrupts the power for traction. Do not enter the areas ahead of and behind the machine. It is very dangerous.

1) Engage the trailer brake and chock its wheels. Fix the ramps so that the machine and trailer are completely aligned.

☆ The angle between the ramps and ground must be less than 15 degrees.

☆ Leave a proper space between the ramps according to the width of the roller drum.

2) Decide the correct direction of run and make the machine run forward to the ramps.

3) Draw the wire rope from the trailer winch and put its hook on the hooking point ① or ② of the roller.

4) Place the unloader valve located at the operator's station to the UNLOAD position (See "Unloader valve" on page 38).

5) With the engine running at idle, perform loading by means of the trailer winch.

6) When the loading is completed, set the unloader valve back in the ONLOAD position.

7) Locate the machine correctly on the trailer.

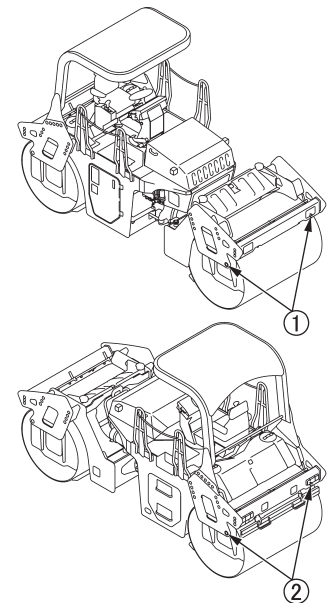
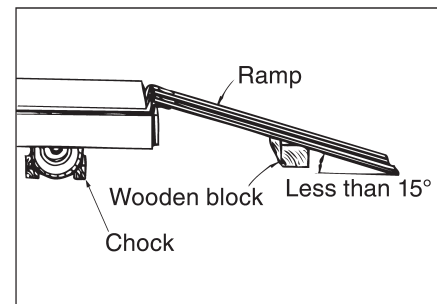

Periodical replacement of essential maintenance parts

In order secure safety for work and travel, conduct inspection and services.

Further, for enhanced safety, following parts and components should be replaced periodically. These parts are prone to material deterioration due to aging or physical change due to wear, while it is difficult to determine their useful limit by regular inspection, which makes it necessary to replace with new ones after certain period of service to maintain their perfect function.

If any abnormality is detected such as crack, deformation, wear or oil leakage, go ahead and replace them even if it is within scheduled replacement time.

System or Mechanism	Part name	Periodical replacement maintenance part	Replacement period	Remarks
1 Brake system	Master cylinder	Seals (rubber parts)	2 years	
	Wheel cylinder	Seals (rubber parts)	2 years	
	Brake piping parts	Brake hose	2 years	
		Air hose	2 years	
Operating parts	Cable	4 years		
2 Steering system	Orbitrol	Seals (rubber parts)	2 years	
	Hydraulic piping parts	Hydraulic hose	2 years	
	Steering cylinder	Seals (rubber parts)	2 years	
	Hydraulic pump	Seals (rubber parts)	4 years	
3 Power transmission system (inclusive of axle)	Axle	Seals (rubber parts)	4 years	
	Travel pump	Seals (rubber parts)	4 years	
	Travel motor	Seals (rubber parts)	4 years	
	Hydraulic piping parts	Hydraulic hose	4 years	
	Isolation rubber	Isolation rubber itself	4 years	
4 Fuel system	Piping parts	Fuel hose	2 years	
5 Engine related	Engine mounting parts	Isolation rubber	4 years	
	Seals (rubber parts)	Packing and others	4 years	
	Drive parts	V-belt	2 years	or 500 hours
	Piping parts	Engine drain hose	4 years	
6 Cooling system	Piping parts	Radiator hose	2 years	
		Radiator drain hose	4 years	
7 Control related parts	Cable	Cable	4 years	
8 Intake system	Piping parts	Intake hose	2 years	
		CAC hose	2 years	
9 Hydraulic system	Hydraulic piping parts	Hydraulic hose	4 years	
10 Urea system	Piping parts	Coolant hose for urea system	2 years	
		Urea hose	9,000 hours	

(3) Every 250 hours

① **Sprinkler pipe**

1) Spray pipe

Remove the cap from both ends of each spray pipe.
Operate the spray pump to wash out dust from inside the pipe.

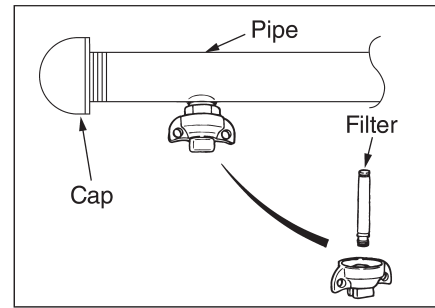

2) Nozzle

- Remove the nozzles from the spray pipe and separate the filter from each nozzle.
- Clean the filters. Use a needle or the like to clean nozzle hole. Refit the filters to the nozzles.
- Fit the nozzles to the pipes so that the water is sprayed in the form of a hand fan in parallel with the pipe.

②③ **Rubber dampers**

Check the rubber blocks for cracks, and their mounting bolts for looseness.

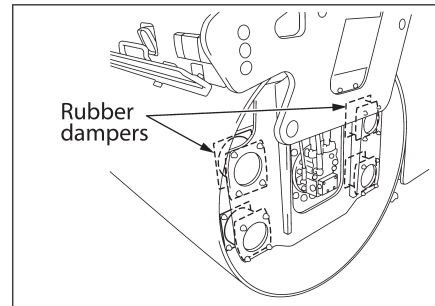

②⑨ **Vibrator**

Check for the oil level and leakage.

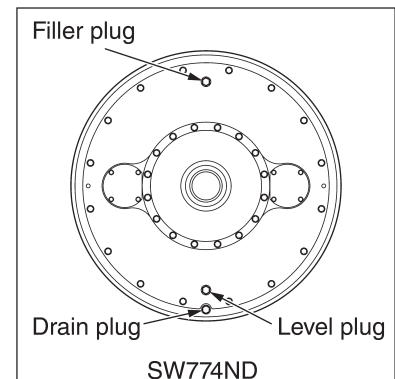
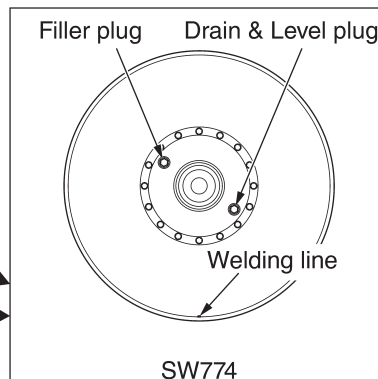
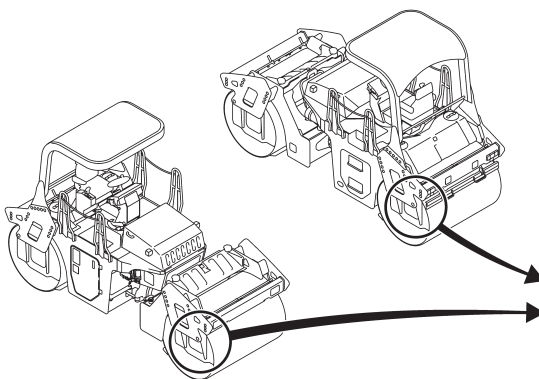

⚠ CAUTION

Be sure to use gear oil recommended by SAKAI (refer to page 107) .

List of replacement parts

It is recommendable that, in addition to friction and separate plates, relevant O-Ring are replaced with new ones as well.

No	Item	Quantity	Drawing # (DAIKIN Dwg.# (Standard JIS Nominal))
			BM55
7	O-Ring	2	1BP10A
29	Separate plate	4	1731865
30	Friction plate	3	SP1081
33	O-Ring	1	1BG170
34	O-Ring	1	1BG195
37	O-Ring	1	1BG145

If it falls in any of the following cases, without waiting for 1,000 operating hours, replace the friction and separate plates altogether.

- 1) When the braking force becomes weaker than driving force of hydraulic motor (Despite that the brake is being actuated, hydraulic motor rotates when HST drive is engaged)
 Checking procedure: While depressing the parking brake switch, open the throttle fully and engage the reversible travel lever. If traveling starts, replace the plates.

- 2) When total thickness of friction and separate plate falls short of the value in the chart below.

Standard dimensions		
Separate plate	4 plates:	2.3 (per plate)
Friction plate	3 plates:	3.3 (per plate)
Total thickness		19.1
Standard total thickness for replacement		18.5

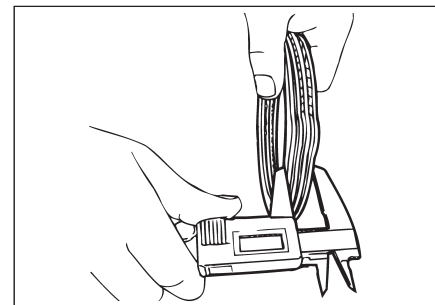

Thickness of separate and friction plates for SW774 and SW774ND are the same.

- Checking procedure: Disassemble and measure the plate thickness in every 500 hours of operation in accordance with the instruction given earlier.

CLICK HERE TO **DOWNLOAD** THE COMPLETE MANUAL

- Thank you very much for reading the preview of the manual.
- You can download the complete manual from: www.heydownloads.com by clicking the link below



- Please note: If there is no response to CLICKING the link, please download this PDF first and then click on it.

CLICK HERE TO **DOWNLOAD** THE COMPLETE MANUAL