

**HYDRAULIC
EXCAVATOR**

UHO7

**OPERATION
MANUAL**



HITACHI
Hitachi Construction Machinery Co., Ltd.

EM164-1-2

CLICK HERE TO **DOWNLOAD** THE COMPLETE MANUAL

- Thank you very much for reading the preview of the manual.
- You can download the complete manual from: www.heydownloads.com by clicking the link below



- Please note: If there is no response to CLICKING the link, please download this PDF first and then click on it.

CLICK HERE TO **DOWNLOAD** THE COMPLETE MANUAL

Table 1. Operating Range

	Long Arm Front Att.		Short Arm Front Att.	
	Back hoe	Shovel	Back hoe	Shovel
	operation. (Hoe bucket natural.)	operation. (Hoe bucket reversed.)	operation. (Hoe bucket natural.)	operation. (Hoe bucket reversed.)
A; Max. cutting radius mm (ft)	9,700 31'10"	9,850 32'4"	8,900 29'3"	9,200 30'2"
B; Max. digging depth mm (ft)	6,360 (20'10")	6,520 (21'5")	5,600 (18'4-1/2")	5,820 (19'1")
C; Max. cutting height mm (ft)	9,030 (29'7-1/2")	9,330 (30'7-3/10")	8,100 (26'6-9/10")	9,130 (29'11-1/2")
D; Max. dumping height mm (ft)	6,280 (20'7-1/5")	6,430 (21'1-1/5")	6,050 (19'10-1/5")	6,280 (20'7-1/5")

Table 2. Type of Hoe Buckets

Type of Hoe Buckets	0.45 (9/16)	0.55 (11/16)	0.7 (7/8)	0.8 (1)	0.9 (1-1/8)	1.2 (1-1/2)
Struck capacity m ³ (cu.yd)	0.4 (1/2)	0.5 (5/8)	0.6 (3/4)	0.7 (7/8)	0.8 (1)	1.0 (1-1/4)
Heaped capacity m ³ (cu.yd)	0.45 (9/16)	0.55 (11/16)	0.7 (7/8)	0.8 (1)	0.9 (1-1/8)	1.2 (1-1/2)
Bucket width mm (ft) (excluding side cutter)	720 2'4-3/8"	870 2'10-1/4"	1,030 3'4-1/2"	1,150 3'9-1/4"	1,330 4'4-3/8"	1,670 5'5-3/4"
Used of front	Long arm Short arm	Long arm Short arm	Long arm Short arm	Long arm Short arm	Short arm only	Short arm only

Note:

1. 1.2 m³ (1-1/2 cu.yd.) hoe bucket can not be used for shovel operation with reversed hoe buckets.
2. Long arm front can not be used for back hoe operation with 0.9 m³ (1-1/8 cu.yd.) or 1.2 m³ (1-1/2 cu.yd.).

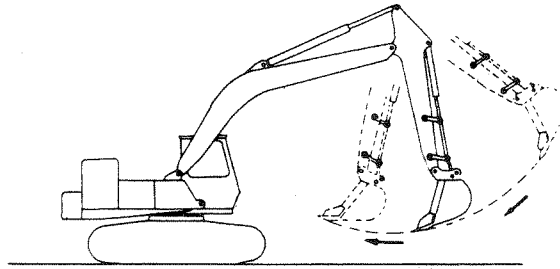
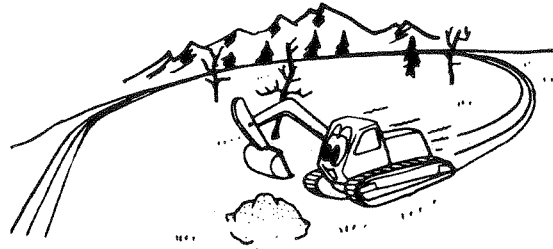

Fig. 8

- b) A noise may be heard from a valve at the start and end of swinging. This is an operating noise of the cushion valve.
- c) The oil reservoir of the UH07 hydraulic excavator is equipped with an air pressure system which does not require air removal in the hydraulic circuit.
- vii) To prevent accidents during operations, pay constant attention to the condition of the surrounding area.

4.7.1 Traction

- 1) If possible, avoid pivot and spin turns and similar movements. When making a turn, turn in as large a curve as permitted.
- 2) When the machine bottom contacts the ground or when mud, sand, gravel, etc. fill the tracks, it may cause traction to become impossible.



In such case; extend the boom and bucket to raise the track on one side at a time.

Then clear the mud, sand or gravel from the track by alternately rotating the raised crawler forward and

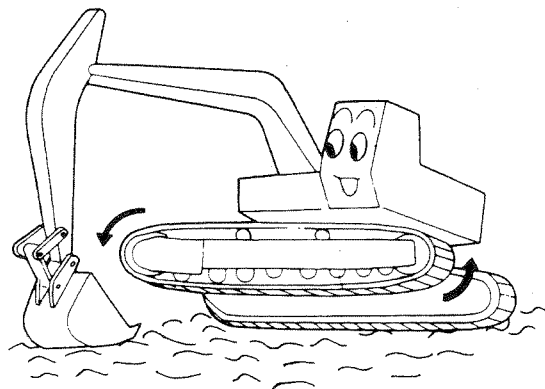

5.1.3 Maintenance and checking every 250 and 500 hours

In addition to the maintenance of sections 5.1.1 and 5.1.2, perform the maintenance listed below.

Maintenance every 250 hours

(1)	Fuel filter	Element replacement	Also clean the interior.
(2)	Full-flow filter	Element replacement	See Fig. 21.
(3)	Drain filter	Check element	Located inside surface of the hydraulic reservoir. (Part No. 317604)
(4)	Air cleaner	Clean dust cup. Cleaning or replacement of element	Refer to par. 5.1.6 check for looseness of hose band.
(5)	Radiator	Change water	Fill the radiator with water to overflow pipe (approximately 35 liters (9.25 US. gal.)).
(6)	Fuel tank strainer	Clean	
(7)	Fuel tank	Remove deposits and water	Remove the flange on the lower side of fuel tank.
(8)	Fan belt	Tension adjustment	
(9)	Nuts and bolts	Perform additional tightening	Refer to table for additional tightening.

5.2 Adjustment

5.2.1 Track link

Track link is adjusted after removing the blind plug (Part No. J75281) for air bleeding, and feeding or removing grease through the valve (Part No. 947221) which is provided with a grease nipple. (See the following sketch when greasing up, loosen the valve (Part No. 433250) and bleed air from the interior of the cylinder.)

Proper slack of the crawler is approximately 75 mm with the crawler raised up using front attachment. If the machine is operated in such soils as sand, snow and gravel mixed with clayey soil which often clog the track link, loosen the crawler-slack twice as described upon: 150 mm. Adjusting range of track-adjustor is 110 mm in full stroke.

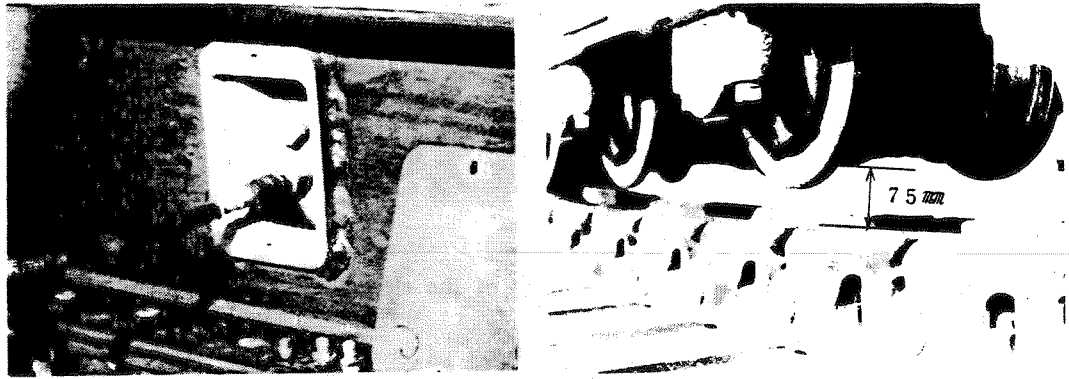

5.2.2 Electrical equipment

For electrical equipment, refer to Instruction Manual for Isuzu DA640.

i) Battery

The efficiency of the battery will greatly affect engine starting. Be sure to maintain the battery in a perfect condition at any times.

Condition of battery	Maintenance and checking
When not in use	<ol style="list-style-type: none">1. Store in a cool place, avoiding direct sunshine.2. When battery is to be left mounted on the machine, be sure to disconnect one terminal (the same applies when the machine is being shipped by freight).3. Check monthly and charge when necessary.4. Charge the battery before reusing it.

replacement of the full-flow filter element.

Always replace both filters at the same time following the procedures described below, referring to Fig. 21.

Exchange Procedure of The Element

1. When exchanging the element, renew the O-ring (3).
2. Disassembly is done following in the ordered of (1) (2) (3) (4).
3. Following precautions are required for reassembling.
 - a) Fully install the element (4). (If the element is fully installed, the top of the element will sink into 33 mm (1-5/16") from the case end. In case of the drain filter, it enters approx. 25 mm (1").)
 - b) Insert O-ring (3) to the groove.
 - c) Install cover (2) keeping the O-ring in the position.
 - d) Tighten bolts (1). (tightening torque 3.5 kg-m (25.3 ft/lbs))
4. Do not let the dust in the filter.
5. Handle the filter element with care and do not hurt it. Broken element is not usable.
6. When exchanging the element, pull in the traction lever on the top of the low-pressure safety valve and fix it. Then remove the air plug located on the upper part of the oil tank. These will lessen unnecessary oil flow out.
7. After exchanging, inspect the hydraulic oil level.

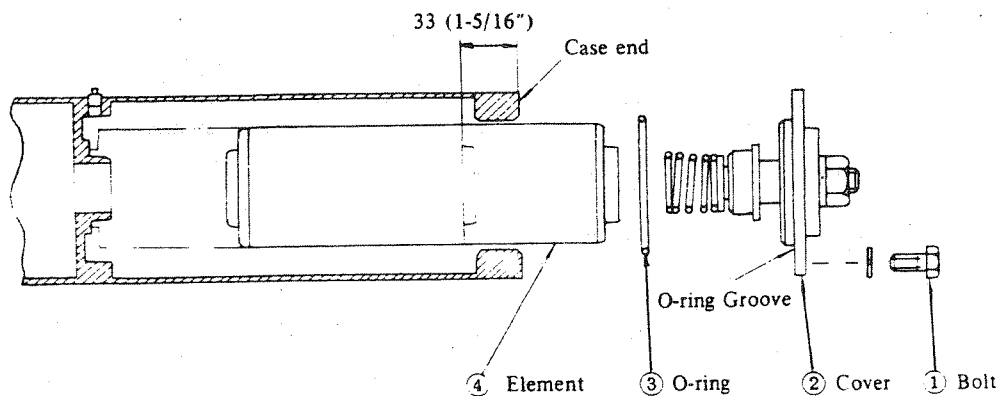
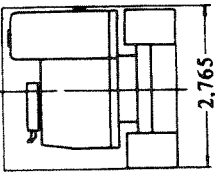
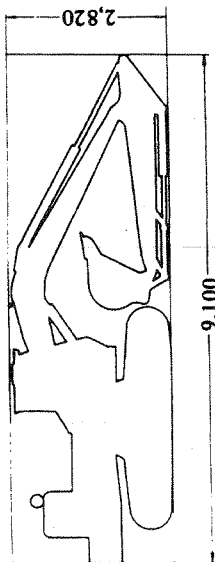
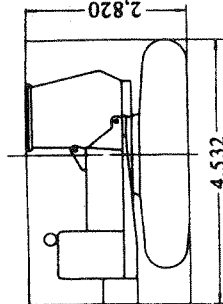
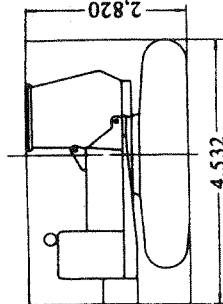
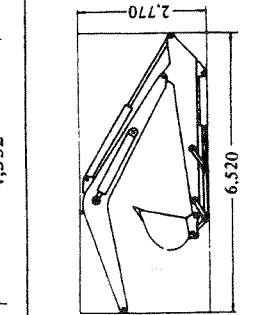
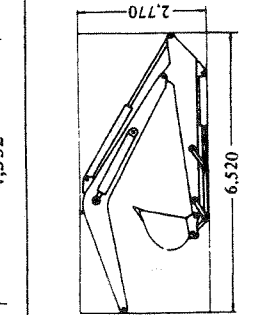
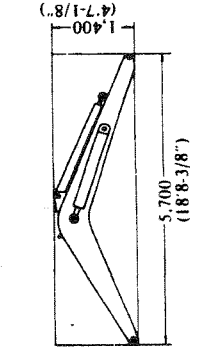
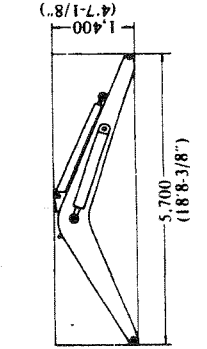
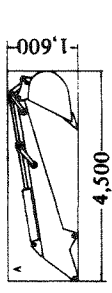
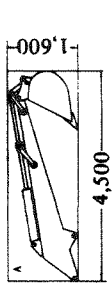
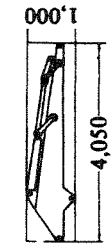
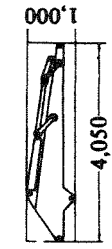
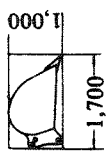
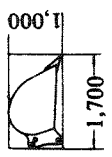

Fig. 21

Packing list (Long Arm Front Attachment)

<p>1. Complete Backhoe Gross Weight 18.0 tons (39,700 lbs) Capacity $9.1 \times 2.82 \times 2.765 = 71.0 \text{ m}^3$</p>		
<p>2. Basic Machine Gross Weight 14.8 tons (32,700 lbs) Width 2,765 mm (9'9/10") Capacity $4.532 \times 2.82 \times 2.765 = 35.3 \text{ m}^3$</p>		
<p>3. Backhoe Front Attachment Gross Weight 3.2 tons (7,060 lbs) Width 1,130 mm (3'8-1/2") Capacity $6.52 \times 2.77 \times 1.13 = 20.4 \text{ m}^3$</p>		
<p>4. Boom Gross Weight 1.60 tons (3,530 lbs) Width 910 mm (2'11-7/8") Capacity $5.7 \times 1.4 \times 0.91 = 7.3 \text{ m}^3$</p>		
<p>5. Arm Bucket Gross Weight 1.55 tons (3,420 lbs) Width 1,130 mm (3'8-1/2") Capacity A $4.5 \times 1.6 \times 1.13 = 8.2 \text{ m}^3$ B $5.4 \times 1.2 \times 1.13 = 7.4 \text{ m}^3$</p>		
<p>6. Arm Gross 0.91 tons (2,000 lbs) Width 460 mm (1'6-1/8")</p>		
<p>7. Bucket Gross 0.64 tons (1,410 lbs) Width 1,130 mm (3'8-1/2") Capacity $1.7 \times 1.13 \times 1.13 = 2 \text{ m}^3$</p>		

CLICK HERE TO **DOWNLOAD** THE COMPLETE MANUAL

- Thank you very much for reading the preview of the manual.
- You can download the complete manual from: www.heydownloads.com by clicking the link below



- Please note: If there is no response to CLICKING the link, please download this PDF first and then click on it.

CLICK HERE TO **DOWNLOAD** THE COMPLETE MANUAL