

GROVE®

GMK 5130-2

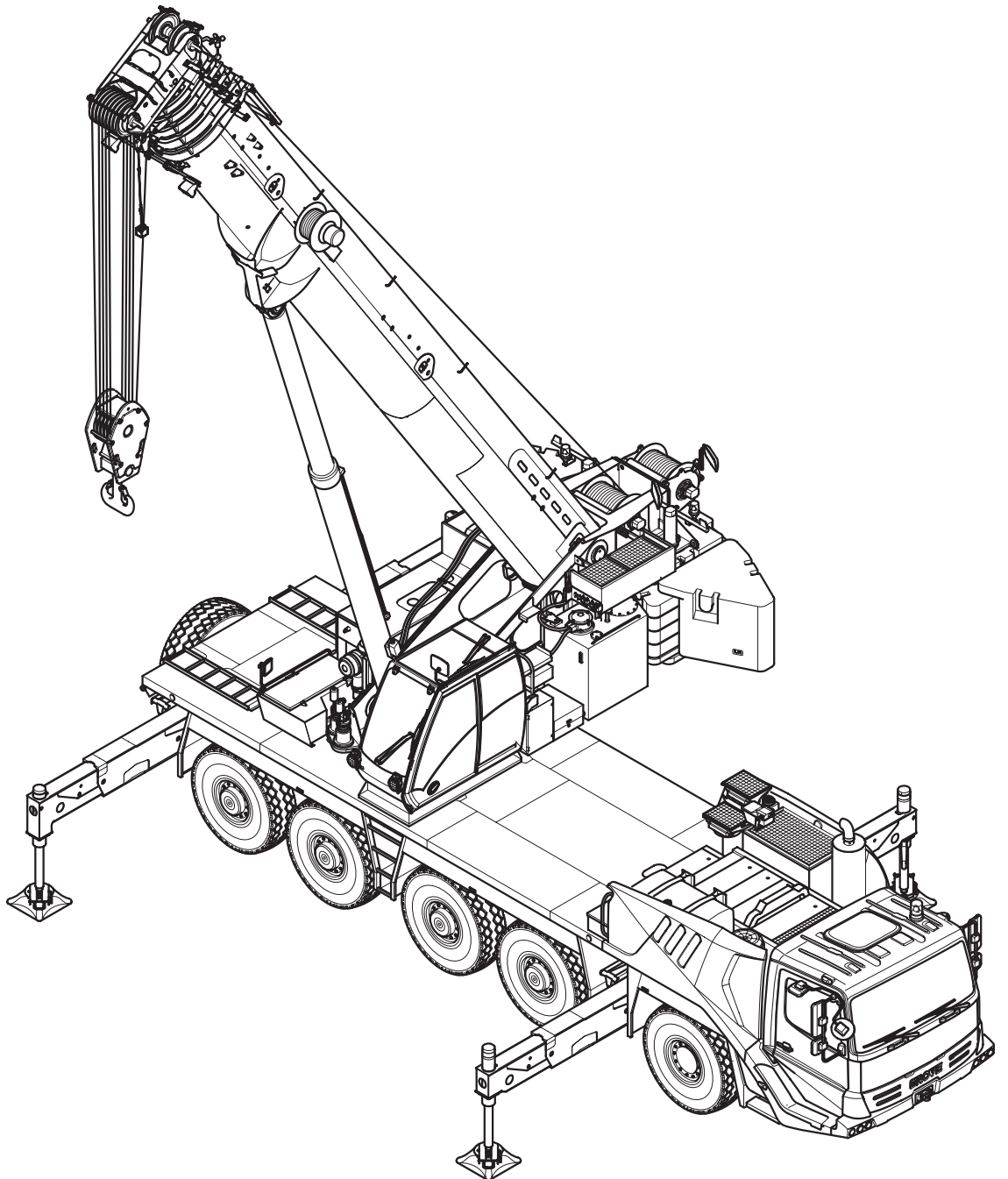

Operating instructions lattice extension



Serial number

3 112 503 en
04.06.2008



A **Manitowoc** Company

CLICK HERE TO **DOWNLOAD** THE COMPLETE MANUAL

- Thank you very much for reading the preview of the manual.
- You can download the complete manual from: www.heydownloads.com by clicking the link below



- Please note: If there is no response to CLICKING the link, please download this PDF first and then click on it.

CLICK HERE TO **DOWNLOAD** THE COMPLETE MANUAL

On the superstructure

The main boom head is always at the front, which means that:

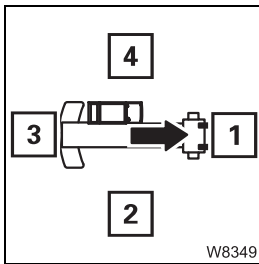

- | | |
|-----------------|-----------------|
| 1: Front | 2: Right |
| 3: Rear | 4: Left |

Switches and buttons

For switches and buttons, the terms **down** and **up** are used.

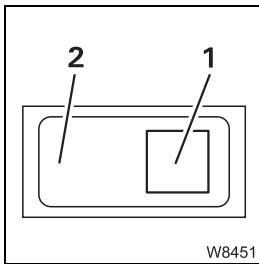

Regardless of the fitting position (vertical, horizontal, diagonal, perpendicular or turned), the following always applies:

- Down:** Press (1) – on the symbol
Up: Press (2) – opposite the symbol

General information on the operating elements

Some switches are provided with a lock button.

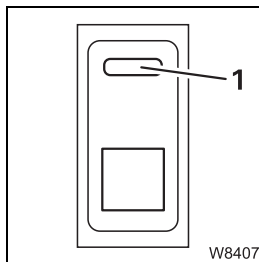

The lock button (1) will not be mentioned again during operation. The following applies to all switches with a lock button:

- **Switching on:** – First press the lock button
– then press lower part of switch down
- **To switch off:** Press top half of switch down until the lock button latches into place

2.2.3

Transport dimensions and weights

The following values apply for the derricking and inclinable swing-away lattice.

Designation	Length x width x height in m (ft)	Weight in kg (lbs)
18 m (59 ft) swing-away lattice, complete, folded up	11.5 x 1.0 x 1.5 (37.8 x 3.3 x 5.0)	1,440 (3,175)
Section 1	11.5 x 1.0 x 1.5 (37.8 x 3.3 x 5.0)	1,100 (2,425)
Section 2	7.2 x 0.6 x 0.7 (23.7 x 2.0 x 2.3)	340 (750)

3 Swing-away lattice

3.1	Validity	3 - 1
3.2	Short description of the operating elements	3 - 3
3.2.1	In the crane cab	3 - 3
3.2.2	Operating elements on the swing-away lattice	3 - 5
3.2.3	Operating elements on the hand-held control	3 - 6
3.3	Checklists for rigging work.	3 - 7
3.3.1	Overview of the required rigging work	3 - 7
3.3.2	CHECKLIST: Installing the 11/18 m (36/59 ft) swing-away lattice	3 - 8
3.3.3	CHECKLIST: Removing the 11/18 m (36/59 ft) swing-away lattice	3 - 10
3.3.4	CHECKLIST: Rigging the 11 m (36 ft) swing-away lattice	3 - 15
3.3.5	CHECKLIST: Rigging the 18 m (59 ft) swing-away lattice	3 - 21
3.3.6	CHECKLIST: Unrigging 11 m (36 ft) swing-away lattice	3 - 27
3.3.7	CHECKLIST: Unrigging 18 m (59 ft) swing-away lattice	3 - 33
3.4	Description of rigging work	3 - 39
3.4.1	Swing-away lattice, securing with rope	3 - 39
3.4.2	Checking the transport condition	3 - 40
3.4.3	Checking the locking device on the hose drum	3 - 45
3.4.4	Position of the hydraulic connections	3 - 46
3.4.5	Establishing/disconnecting the hydraulic connection	3 - 47
3.4.6	Folding the run-up rail out/in	3 - 48
3.4.7	Connections when the swing-away lattice is folded up	3 - 49
3.4.8	Connections on the left and right of the main boom head	3 - 61
3.4.9	Swinging the swing-away lattice on to the main boom head	3 - 66
3.4.10	Slewing the swing-away lattice when rigging	3 - 67
3.4.11	Connections to the swing-away lattice, establishing/disconnecting	3 - 71
3.4.12	Electrical connections to the swing-away lattice	3 - 73
3.4.13	Folding deflection sheave out/in	3 - 76
3.4.14	Positioning/removing the hoist rope	3 - 78
3.4.15	Installing/removing the lifting limit switch	3 - 80
3.4.16	Installing/removing the anemometer	3 - 83
3.4.17	Air traffic control light – electrical connection	3 - 85
3.4.18	Swing-away lattice, derricking	3 - 87
3.4.19	Setting the angle – with the auxiliary crane	3 - 91
3.4.20	Setting the angle – without the auxiliary crane	3 - 92
3.5	Operation with swing-away lattice	3 - 99
3.5.1	Setting the SLI	3 - 99
3.5.2	Derricking the main boom	3 - 101
3.5.3	Telescoping with rigged heavy load lattice extension	3 - 102
3.5.4	Information about the SLI shutdown	3 - 103



Risk of crushing due to swinging swing-away lattice

Always secure the swing-away lattice against swinging with the guide ropes before you establish the hydraulic or electrical connection. This will prevent the swing-away lattice from swinging inadvertently to the side of the main boom and possibly crushing you.

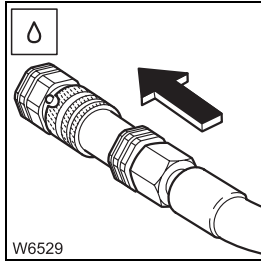

5. For derricking swing-away lattice, establish a hydraulic connection; **▶▶▶▶▶** p. 3 - 47.

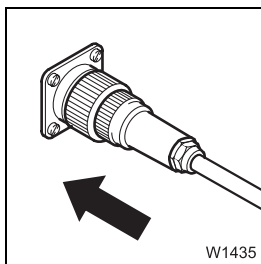

6. Establish the electrical connection; **▶▶▶▶▶** p. 3 - 73.

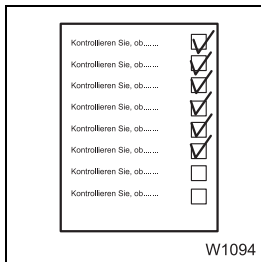

7. For further folding of:

11 m (36 ft) swing-away lattice:

CHECKLIST: Unrigging 11 m (36 ft) swing-away lattice from point 10. ▶▶▶▶▶ p. 3 - 28.

18 m (59 ft) swing-away lattice:

CHECKLIST: Unrigging 18 m (59 ft) swing-away lattice from point 15. ▶▶▶▶▶ p. 3 - 35.

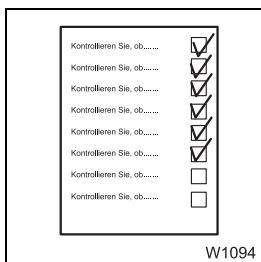

8. For further rigging of:

11 m (36 ft) swing-away lattice:

CHECKLIST: Rigging the 11 m (36 ft) swing-away lattice from point 13. ▶▶▶▶▶ p. 3 - 17.

18 m (59 ft) swing-away lattice:

CHECKLIST: Rigging the 18 m (59 ft) swing-away lattice from point 13. ▶▶▶▶▶ p. 3 - 23.

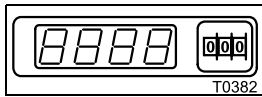

- 24.** Enter the current rigging mode with the rigged swing-away lattice;
 ▶▶▶▶▶ *Setting the SLI*, p. 3 - 99.

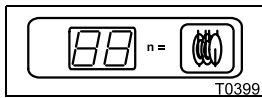

- 25.** Enter current reeving; ▶▶▶▶▶ *Setting the SLI*, p. 3 - 99.

Further steps with swing-away lattice:

- Raise main boom; ▶▶▶▶▶ p. 3 - 101.
- Telescope main boom; ▶▶▶▶▶ p. 3 - 102.

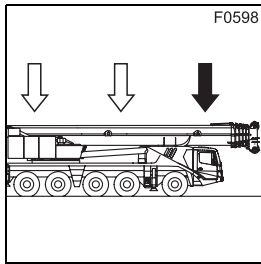

12. In the *Front* area, move the connection into the *Unrigging* position;  p. 3 - 53.

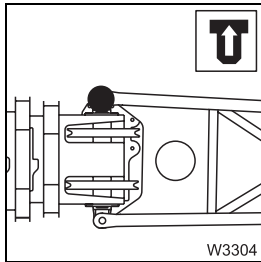

13. Disconnect the connection between section 1 and the main boom head at the left of the main boom head;  *Left-hand connection*, p. 3 - 62.

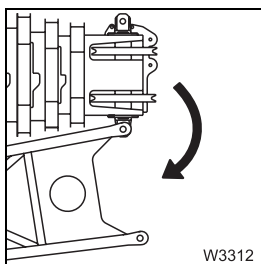

14. Swing the lattice extension on to the side of the main boom with the guide rope;  *When unrigging – section 1*, p. 3 - 68.

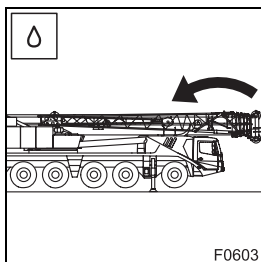

15. Lower the derricking swing-away lattice so that it is positioned on the run-up rail.

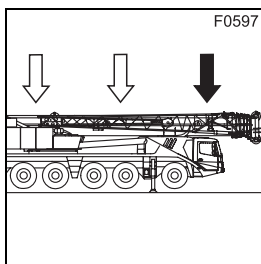

16. Establish the connection in the *Front* area;  *Establishing a connection*, p. 3 - 50.

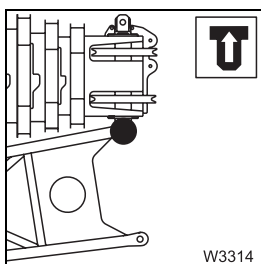

17. Disconnect the connection between section 1 and the main boom head at the right of the main boom head;  *Right-hand connection*, p. 3 - 61.



3.4

Description of rigging work

3.4.1

Swing-away lattice, securing with rope

When the truck crane isn't favourably aligned, the swing-away lattice can swing around independently if you disconnect the last connection to the main boom.



Risk of accidents due to the swing-away lattice swinging of its own accord

Always secure the swing-away lattice with a guide rope on the main boom before disconnecting anything.

This will prevent the swing-away lattice from swinging around of its own accord and pushing you off the crane base or causing injury to you or other persons.

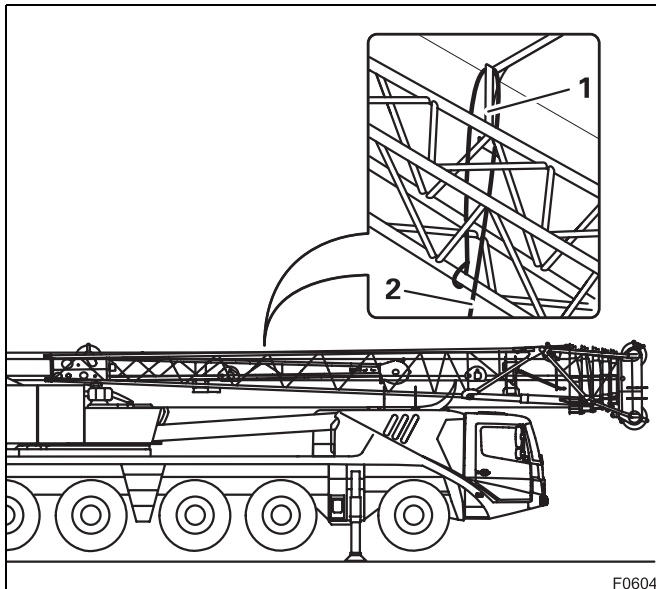

Secure the swing-away lattice in the following manner:

- Attach a rope (2) at the front of the swing-away lattice.
- Guide the rope underneath the swing-away lattice, over the rope guide (1) on the main boom and back again.
- Have a helper hold the rope tight while you are releasing the last connection.



If you are alone, secure the other end of the cord on the crane (depending on the slewing direction of the superstructure, e.g. on the rear right on the outrigger beam or on the left on the steps of the access ladder to the carrier).

3.4.7

Connections when the swing-away lattice is folded up

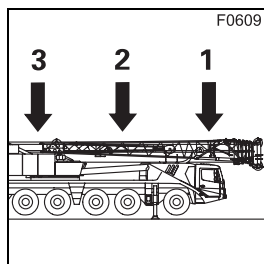

If the swing-away lattice is swung across to the main boom, there are four areas on the main boom where various connections must be disconnected during rigging:

- 1 *Front* area, in front of the locking point at 100%
- 2 *Middle* area, in front of the locking point at 50%
- 3 *Rear* area, under the side panelling

Depending on the rigging mode and job, different sections of the swing-away lattice have to be connected one below the other or with the main boom basic section.



Risk of accidents due to falling parts!

Always secure the pins both in the bearing points and in the holders using retaining pins.

This prevents unsecured pins from coming loose, falling out and causing injuries.

Connections in the front area

In the *Front* area, there is a connection between section 1 and the main boom.

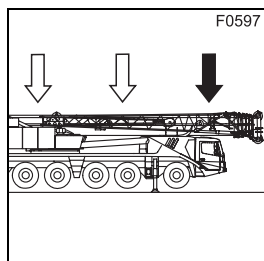

This connection must be established if the lattice extension is folded at the side of the main boom during unrigging or installation.

The connection must be removed when the lattice extension is being rigged or removed.

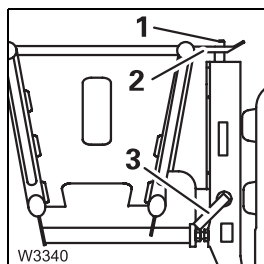

The connection consists of the pin (3), the slewing axis (1) on the basic section and the holder (2) on section 1.



Releasing the connection

- Check if the connection is made in the *Front* area; ■■■► p. 3 - 50.

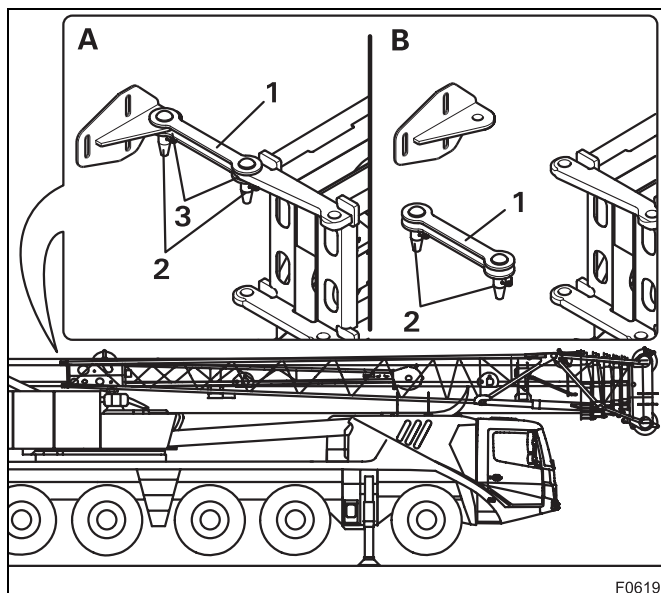

- **(A)** – pull the pin (2) out of the connecting points (3).
- Remove the retaining strut (1).
- **(B)** – Fasten the retaining strut (1) to the main boom with a pin (2).
- Secure the pins using the retaining pins.
- Stow the retaining strut with the pins for crane operation (e.g. in the storage box).

Connection between section 1 and section 2.

All information in this section only applies to the operation of the 11 m (36 ft) swing-away lattice, if section 2 is fitted.

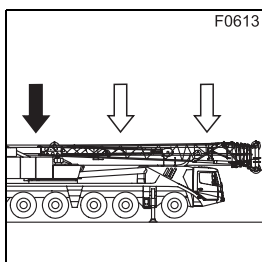

This connection is made after the 11 m (36 ft) swing-away lattice has been swung to the side of the main boom during unrigging.

This connection is released before the 11 m (36 ft) swing-away lattice is swung to the side of the main boom during rigging.



When rigging – section 2

When rigging the 18 m (59 ft) swing-away lattice you must also swing out section 2 in front of section 1.



Risk of accidents through section 2 swinging of its own accord

Always secure section 2 with a guide rope before you release the connection between section 1 and section 2 and only position the ladder on the left at section 1.

In this way you prevent section 2 from swinging round of its own accord when the connection is released and knocking you off the ladder.

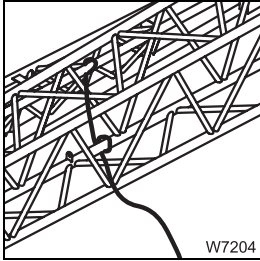

- Fasten a guide rope to the front at section 2.
- Secure section 2 against swinging round.
Get a helper to hold the guide rope taut, or fasten it to the bottom of section 1.

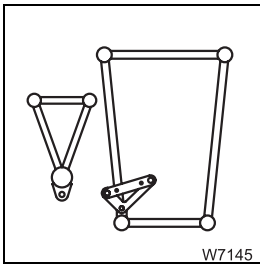

- In the *Middle* area, move the connection into the position *Section 1*;
▶▶▶ p. 3 - 55.



Risk of accidents through section 2 swinging round

Make sure that there are no people or objects in the slewing range of the swing-away lattice and always swing out the swing-away lattice with a guide rope from the ground.

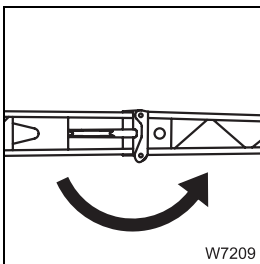

- Swing section 2 in front of section 1 using the guide rope.
- Secure section 2 against swinging round.
Get a helper to hold the guide rope taut.

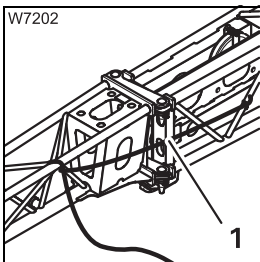

- If you are working alone, secure section 2 from swinging round on the left-hand side at section 1 using a second guide rope (1).
- Establish the left-hand connection between section 2 and section 1;
▶▶▶ p. 3 - 71.



CLICK HERE TO **DOWNLOAD** THE COMPLETE MANUAL

- Thank you very much for reading the preview of the manual.
- You can download the complete manual from: www.heydownloads.com by clicking the link below



- Please note: If there is no response to CLICKING the link, please download this PDF first and then click on it.

CLICK HERE TO **DOWNLOAD** THE COMPLETE MANUAL

During operation

Switching on the derricking gear

All power units are switched off and the lamps in the corresponding buttons light up only dimly after the ignition is switched on.

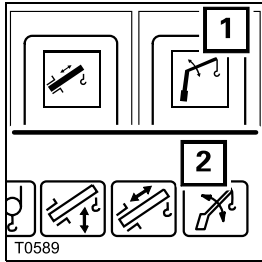

- Press the button (1) once.
 - The lamp in button (1) lights up brightly.
 - The symbol (2) is **green** if the derricking gear is switched on.

If the control lever is assigned more than one function, all other power units which are assigned the same control lever operation are switched off.

Raising and lowering

You can adjust the sensitivity of the control levers to the operating conditions; *Operating instructions GMK 5130-2*.



Risk of accidents due to unexpected crane movements!

In the case of multiple configuration, check whether the control lever function *Derricking* is switched on before you move the control lever for derricking.

This way, you avoid accidents due to unexpected crane movements.

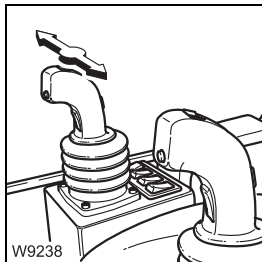

To lower: Push the control lever to the right – the swing-away lattice is lowered.

To raise: Push the control lever to the left – the swing-away lattice is raised.

The maximum derricking speed is automatically reduced as the system length is increased. If you now reduce the working radius (e.g. by retracting the telescoping), the derricking speed is automatically increased again.

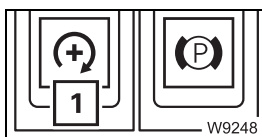

You can set the desired engine speed (idling speed) with the button (1); *Operating instructions GMK 5130-2*.

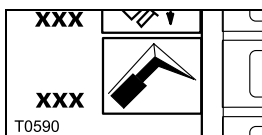

You can limit the maximum derricking speed; *Operating instructions GMK 5130-2*.



3.5

Operation with swing-away lattice



When operating the swing-away lattice, the maximum speed for the different power units is limited to 70%; *Operating instructions GMK 5130-2.*

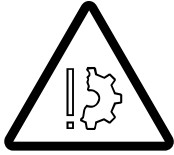

Risk of damage to main boom

During operation with the 11 m (36 ft) swing-away lattice with a 0° angle at the steepest boom position, the head sheaves at the main boom can be damaged when a hook block is raised or lowered.

Reduce the hoist speed so that the hook block is raised slowly passed the head sheaves.

The raising, lowering, slewing, derricking and telescoping movements are carried out in the same way as when operating with the main boom. This section only contains information that you will need for a rigged or installed swing-away lattice:

3.5.1

Setting the SLI



If a hook block is reeved on the main boom during operation with the lattice extension, the loads given in the *lifting capacity tables* decrease and the SLI subsequently switches off earlier.

The values which must be deducted from the load capacities depend on the length of the lattice extension and the weight of the hook block. You will find a table with the values in the *lifting capacity tables* in the section *Information on working with the swing-away lattice extension.*

When operating with a swing-away lattice

Components which must be input in addition to the SLI are:

with a derricking swing-away lattice: The length

with an inclinable swing-away lattice: The length and the angle



4 Boom extension

4.1	Checklists for rigging work.	4 - 1
4.1.1	CHECKLIST: Rigging the 26/32 m (85/105 ft) boom extension	4 - 1
4.1.2	CHECKLIST: Unrigging the 26/32 m (85/105 ft) boom extension	4 - 6
4.2	Description of rigging work	4 - 11
4.2.1	Installing/removing section 3 and section 4	4 - 11
4.2.2	Installing/removing the swing-away lattice for the boom extension	4 - 13
4.2.3	Hydraulic connection at the boom extension	4 - 14
4.2.4	Electrical connection on the boom extension	4 - 17
4.2.5	Fold the deflection sheave in/out on section 3	4 - 20
4.2.6	Positioning/removing the hoist rope	4 - 21
4.3	Operation with boom extension	4 - 23
4.3.1	Setting the SLI	4 - 23
4.3.2	Derricking the main boom	4 - 24
4.3.3	Telescoping with rigged boom extension	4 - 24
4.3.4	Information about the SLI shutdown	4 - 25
4.3.5	Procedure if permissible wind speed is exceeded	4 - 25
4.3.6	Notes on two-hook operation	4 - 25

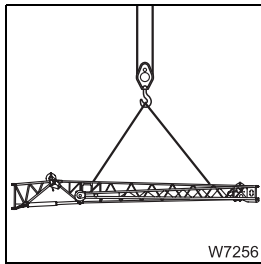

17. Sling the swing-away lattice on auxiliary crane and fasten the guide ropes; ■■■► *Slinging points*, p. 2 - 6.

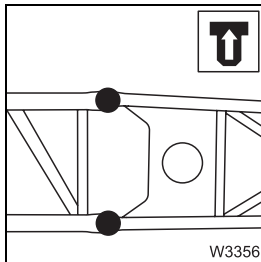

18. Remove the folded up swing-away lattice; ■■■► *Installing/removing the swing-away lattice for the boom extension*, p. 4 - 13.

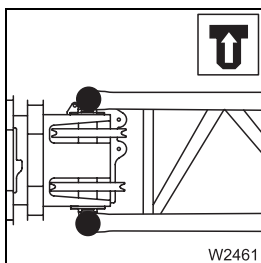

19. Sling the rigged sections onto the auxiliary crane and remove from the main boom:

- For the 26 m (85 ft) boom extension section 3,
- For the 32 m (105 ft) boom extension section 4 and section 3;

■■■► *Slinging points*, p. 2 - 6.

■■■► *Installing/removing section 3 and section 4*, p. 4 - 11

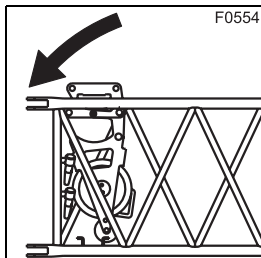

20. Fold in the deflection sheaves on section 3; ■■■► *Folding in the deflection sheave*, p. 4 - 20.

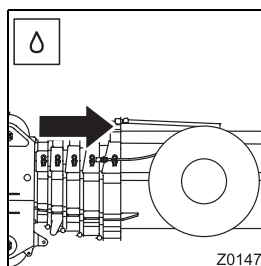

21. Only applies for the derricking swing-away lattice:
- Position hydraulic hoses for working with the main boom;
■■■► p. 3 - 46.

Connection to the swing-away lattice

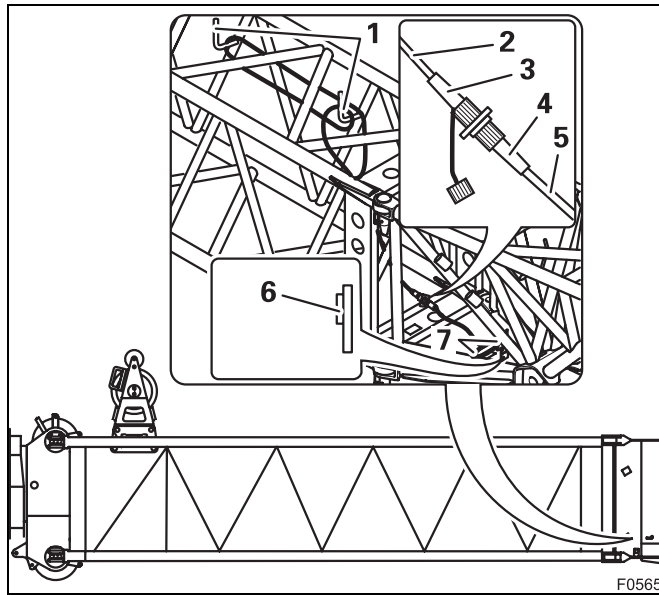

Establishing a connection

- Unwind the cable (2) from the clamp (1) in section 3.
- Guide the cable (2) as far forward as possible to section 1.
- Pull the cap off the socket (3).
- Unwind the cable (5) from the clamp (7).
- Change over the plug (4) from the dummy socket (6) and to the socket (3).
- Wind up the cable (5) far enough on the clamp (7) so that it does not sag.
- Wind up the cable (2) far enough on the clamp (1) so that it does not sag.

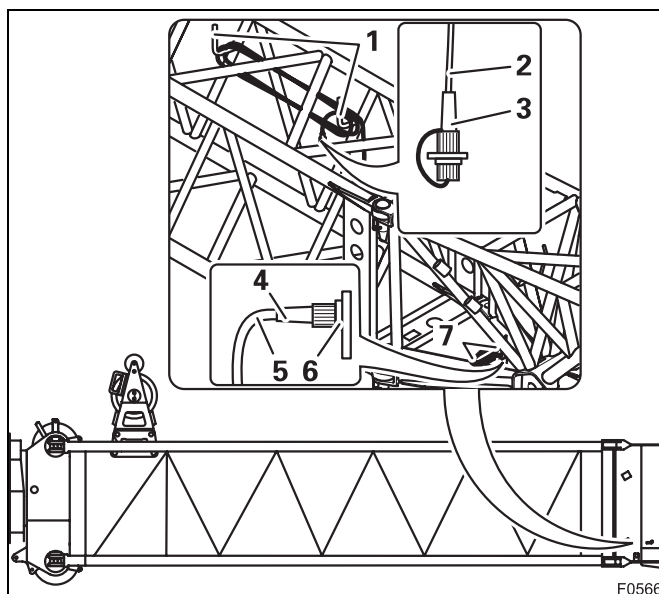

Disconnecting the connection

- Change over the plug (4) from the socket (3) to the dummy socket (6).
- Wind the cable (5) on to the clamp (7).
- Close the socket (3) with the protective cap.
- Guide the cable (2) to the rear through section 4 and section 3.
- Wind the cable (2) on to the clamp (1) in section 3.

5

Auxiliary single-sheave boom top

5.1



Installing/removing

5.1.1

Installing/removing the auxiliary single-sheave boom top

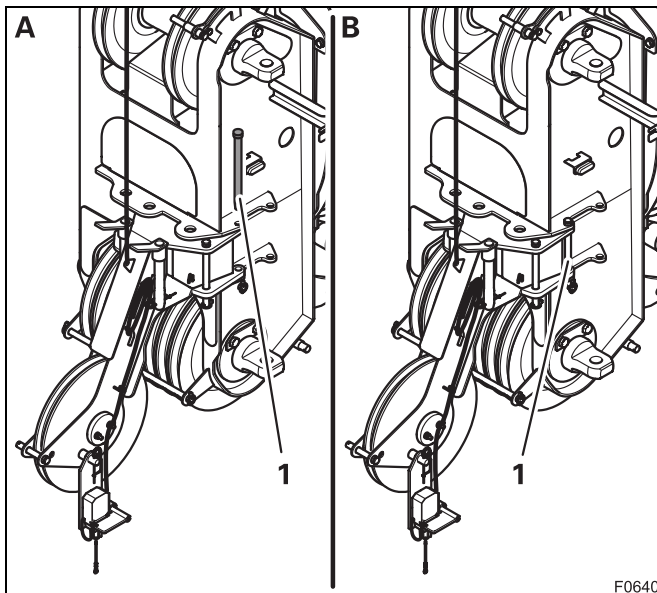
Support



- (A) – Sling the auxiliary single-sheave boom top;  p. 2 - 13.
- Pull out the pin (1).
- Hoist the auxiliary single-sheave boom top in front of the clamp.
- Align the auxiliary single-sheave boom top so that the bearing point lines up to the front bore holes in the clamp.
- (B) – Insert the pin (1) and secure it with a linch pin.
- Move the auxiliary single-sheave boom top into the transport position or working position;  *Rigging the auxiliary single-sheave boom top*, p. 5 - 3.



5.3.5

SLI display with the auxiliary single-sheave boom top folded up/rigged

If the auxiliary single-sheave boom top on the main boom is fitted in the working position or the transport position, the lifting capacities listed in the *Lifting capacity tables* are lower.

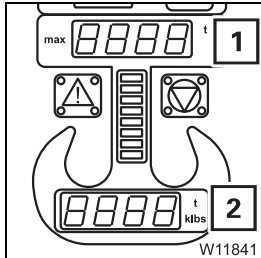

The *Maximum load* display (1) does **not** show the reduced values.

However, the SLI takes into account the value for the currently fitted auxiliary single-sheave boom top, adds the weight of the raised load and displays the sum on the *Current load* display (2). The SLI switches off correspondingly earlier.

5.3.6

Notes on two-hook operation

Notes on two-hook operation;  *Turning loads*, p. 6 - 1.

7 Driving with a rigged crane

7.1	Safety instructions	7 - 1
7.2	Driving distance	7 - 3
7.3	Rigging mode and axle loads	7 - 3
7.4	Before driving the rigged truck crane	7 - 5
7.5	Driving the rigged truck crane	7 - 5
7.6	Tables with boom positions and axle loads	7 - 7
7.6.1	Swing-away lattice	7 - 8
7.6.2	Boom extension	7 - 12
7.6.3	Auxiliary single-sheave boom top	7 - 16

Counter-weight in t (lbs)	Telescoping Telescopic section I-II-III-IV-V	Main boom angle	Lattice exten- sion incli- nation	Main boom position ¹⁾	Maximum axle load ²⁾ in t (x 1,000 lbs)	
					Front	Rear
23.5 (51,800)	Values not available yet.					
26.0 (57,400)						
28.5 (62,800)						
40.1 (88,400)						

1), 2)  Information about the tables, p. 7 - 7



8

Maintenance



Observe general notes and the information on safety and environmental protection in the *Maintenance manual*.

In this chapter you will find the information required for the maintenance of the lattice extensions.

- Maintenance intervals as in the *Maintenance manual* of the truck crane delivered; observe the factors that shorten the intervals;
- run-in regulations for the lattice extensions are not intended;
- periodic inspections are not intended.

8.1

Cleaning



Follow the instructions for cleaning work with high-pressure cleaners in the *Maintenance manual*.

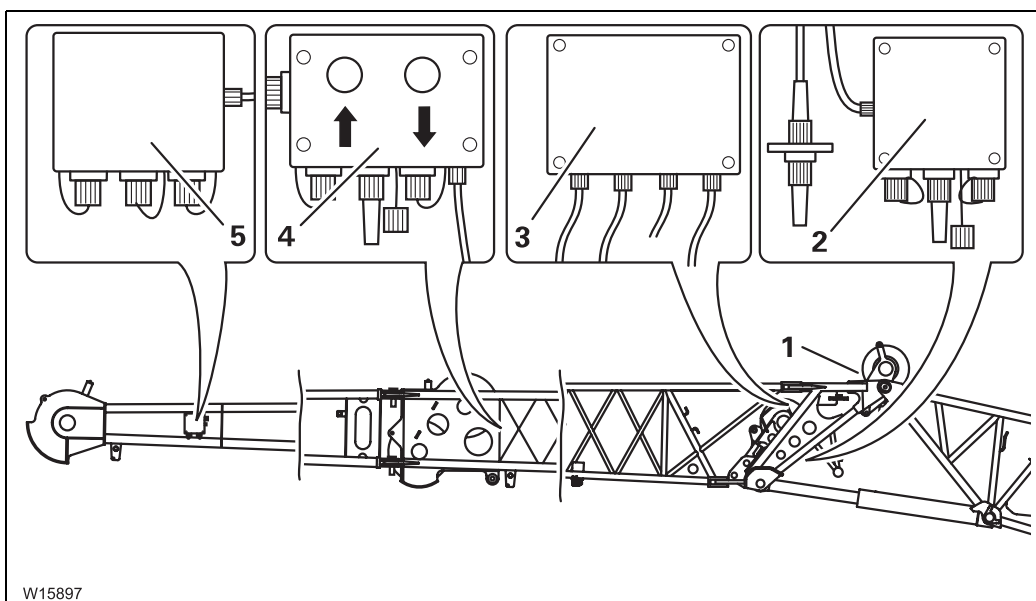

- Provide protection for the following electrical parts during cleaning work:

- 1 Potentiometer in the joint of section 1
- 2 Switch box at the rear of section 1
- 3 Switch box at the front of section 1
- 4 Switch box at the front of section 2

CLICK HERE TO **DOWNLOAD** THE COMPLETE MANUAL

- Thank you very much for reading the preview of the manual.
- You can download the complete manual from: www.heydownloads.com by clicking the link below



- Please note: If there is no response to CLICKING the link, please download this PDF first and then click on it.

CLICK HERE TO **DOWNLOAD** THE COMPLETE MANUAL