



Operation Manual

Bucyrus - UN-A-HAULER[®]

**Model - CH810B, CH816B,
CH816LB, and CH818**

Doc. No.: A6474X211



Bucyrus America, Inc.

4041 Wurno Road
Pulaski, VA

Telephone: 540-980-4530
Fax: 540-994-3763

Internet: www.bucyrus.com

CLICK HERE TO **DOWNLOAD** THE COMPLETE MANUAL

- Thank you very much for reading the preview of the manual.
- You can download the complete manual from: www.heydownloads.com by clicking the link below



- Please note: If there is no response to CLICKING the link, please download this PDF first and then click on it.

CLICK HERE TO **DOWNLOAD** THE COMPLETE MANUAL



Before starting to work

Characters and symbols used

The following characters and symbols are used for safety instructions and important information in the operating manual.

Try to memorize the symbols and their meanings.



DANGER!

Points in the text marked with this symbol draw your attention to immediately impending danger. Possible consequences are: very serious injury or even death.



WARNING!

These points contain information on dangerous situations. Possible consequences are: very serious injury or even death.



CAUTION!

This symbol draws attention to dangerous situations. Possible consequences are: light to moderately serious injuries and machine damage.



NOTICE!

Points in the text marked with this symbol draw attention to harmful situations. Possible consequences are: damage to the machine or damage in the immediate vicinity.



IMPORTANT!

Points in the text marked with this symbol contain useful tips and information intended to facilitate work for you. They do not warn about harmful or dangerous situations.

- Items in lists are marked with bullets.
 - Points in sub-lists are marked with a long dash at the start of the line.
- ☞ Points in text marked in this way describe individual operations. Follow these instructions step by step. They will help you carry out your work faster and more importantly, safer.

Overview of safety instructions



Installation and start-up

inclined face	On inclined faces secure all component parts by chains, e.g. to the support.
environmental acceptability	When working with oils, greases and other chemical substances, observe the safety regulations applicable to the product. Dispose of cleaning rags, etc. which have been soiled with oil, grease or other chemical substances in an environmentally safe manner.
controls	When starting up machine, do not operate any controls located inside the operator's compartment from outside the compartment.
starting procedures	Follow the starting procedure instructions in chapter 5 of this manual.
hazard zone	Do not operate any levers, pedals or controls if anyone is in the hazard zone. (See Hazard zone in Chapter 5 of this manual)

Operation

training	Operate the machine only if you have a profound knowledge of the control elements and their functions. It is necessary that you have been task trained on the respective UN-A-HAULER ©.
before start-up	Before start-up, ensure that there are no persons or obstructions in your line of travel or in the articulation area when steering the unit.
protective devices	Check that all protective devices are installed on the machine and function properly.
operator's compartment	Clean the operator's compartment at regular intervals. Ensure that the operating symbols are legible in order to avoid any operator errors and resulting accidents. Never climb onto, or climb out of the machine while it is in motion. Do not operate the machine with any part of your body outside of the operator's compartment in order to prevent body parts from being crushed between the machine and outside objects .
traveling	Use extreme caution when traveling in close quarters or in congested or blind-travel areas. The warning gong should be sounded to alert personnel of your movement.
passengers	Never carry passengers to prevent the passengers from being thrown off or crushed between the machine and outside objects.
safety rules	Always follow all safety rules of each particular mine when operating the machine.
problems and malfunctions	If problems or malfunctions are encountered while operating the unit, it must be properly shutdown and the problem corrected immediately.



Overview of safety instructions



CAUTION!

Be sure that the battery is properly aligned over the battery latch before moving away from the battery table.



CAUTION!

If the battery is not completely lowered before the UN-A-HAULER® leaves the battery change station, the battery may fall off or hit the roof and be damaged.



WARNING!

The "battery" change control lever should never be operated except at a battery change station or when it's necessary to adjust the battery's terrain clearance. If the "battery" change control lever is operated in a low roof area, the battery may be damaged.



WARNING!

Never attempt to disconnect a hydraulic hose from the battery lifting cylinders while the battery is in the up position. This could cause the battery to fall and could result in serious injury.



WARNING!

Before performing maintenance on the machine, disconnect the electrical power. Either the battery circuit breaker or the machine circuit breaker must be in the "OFF" position. If work is to be done inside the electrical controller, the battery should be disconnected. Also make sure the capacitor discharge module indicates that the capacitors are discharged before working inside the controller. Electrical shock and accidental machine movement can cause serious injuries or even death to you or the maintenance person.



WARNING!

Do not move any hydraulic control lever unless you are certain that everyone is completely clear of any machine movement. Accidental machine movement can cause serious injuries or even death to you or the maintenance person.



WARNING!

You could be seriously injured or even killed by falling loads. Observe the safe working load limits of lifting or blocking devices and keep a safe distance from suspended loads.



NOTICE!

If any welding is to be done to machine, the circuit breakers must be in the "OFF" position and the batteries disconnected. Failure to do so may cause electrical component damage.



IMPORTANT!

The drive and pump motors do not require periodic lubrication. The pump motor bearings are sealed. The drive motors have one bearing sealed and the other bearing receives lubrication from the gear case oil.



CAUTION!

Do not adjust the hydraulic system pressure to more than the main system setting shown on the hydraulic schematic drawing located in the replacement parts manual for your particular machine.

4 Installation





Operation

This chapter contains important information on the operation and maintenance of the machine. It also includes instructions on the replacement of wear parts.

Read this chapter carefully and thoroughly. In particular, observe the safety instructions in chapter 2 “Your safety”.

How to operate the UN-A-HAULER®



DANGER!

Incorrect operation endangers yourself and others!

Incorrect operation of the machine is often the cause of very serious accidents!

Operate the unit only when you have been sufficiently trained on the machine and have read and understood this operating manual. Should anything be unclear, please contact your immediate supervisor.

Who is allowed to operate the UN-A-HAULER®?

The UN-A-HAULER® is only allowed to be operated by persons with adequate knowledge of the complete machine.

This also includes:

- what safety devices are installed on the machine.
- where these safety devices are located.
- how these safety devices are to be operated.

When can operation be started?

Operation must not be started until the safe condition and proper function of the complete machine has been checked and the daily maintenance operations have been carried out.



“STEERING” control lever

The “STEERING” control lever to the left of the operator (Fig. 18) is used to steer the UN-A-HAULER®. To steer left while moving forward (right while moving in reverse), pull the steering control lever slowly toward the operator. To turn right while moving forward (left while moving in reverse), push the steering control lever slowly away from the operator.

“EJECTOR” control lever

The "EJECTOR" lever (Fig. 18), operates the ejector blade/false bottom, located in the rear section. The ejector blade/false bottom pushes out everything in its path, emptying the rear section. When the "EJECTOR" lever is pushed by the operator, the ejector blade/false bottom should move toward the rear of the unit (extend). When the "EJECTOR" lever is pulled by the operator, the ejector blade/false bottom should move toward the operator (retract). When the ejector blade/false bottom is not being used, it should be resting in the retracted position.



WARNING!

Before moving the ejector blade/false bottom control lever, verify that no one has any part of his body between the ejector blade/false bottom and the front of the rear (payload) section. Also keep any obstructions from behind the ejector blade/false bottom so it can return completely to the front of the rear (payload) section.

“BATTERY CHANGER” control lever

The "BATTERY CHANGER" lever (Fig. 18) controls the battery changing system, which is made up of two hydraulic cylinders (battery lifting cylinders), one on each side of the battery. When the "BATTERY CHANGER" control lever is pulled by the operator, the battery-lifting cylinders will raise the battery. Pushing the handle away from the operator will lower the battery. On vertical lift battery change systems the battery lift cylinders are equipped with passive hold-down devices to prevent the battery from moving inside the machine. The hold-down pressure is regulated by a relief valve in the system (refer to the Maintenance section of this guide).



CAUTION!

The "BATTERY CHANGER" lever should only be operated at a battery change station. The battery may be damaged if accidentally raised in a low roof area.



WARNING!

The battery cannot be changed if the battery is not level when in the raised position. For more information on how to change the battery see Battery change procedure in this chapter.



WARNING!

Never attempt to disconnect a hydraulic hose from the battery lifting cylinders with the battery in the "UP" position. This would allow the battery to fall and could result in injury.



Battery change procedure (Vertical lift)

Two people are needed to change the battery in the UN-A-HAULER[®]. Since one person may step into the Hazard Zone, the other person (operating the UN-A-HAULER[®]) must be very careful and look each time before moving any levers or pedals. Take time now to re-familiarize yourself with the Hazard zone (Fig. 20).



WARNING!

The UN-A-HAULER[®] is equipped with a passive battery hold-down system. This system keeps the battery resting securely on the frame while the UN-A-HAULER[®] is in operation. The battery hold-down system requires no operator assistance. However, it is important that the battery be properly aligned over the battery latch.



NOTICE!

The battery table must be placed on level ground and the tires fully inflated (155 psi).

- ☞ Line up the battery end of the machine with an empty battery table (Fig. 23) (see Starting procedure in this chapter).

Fig. 23: Battery change procedure (vertical lift)

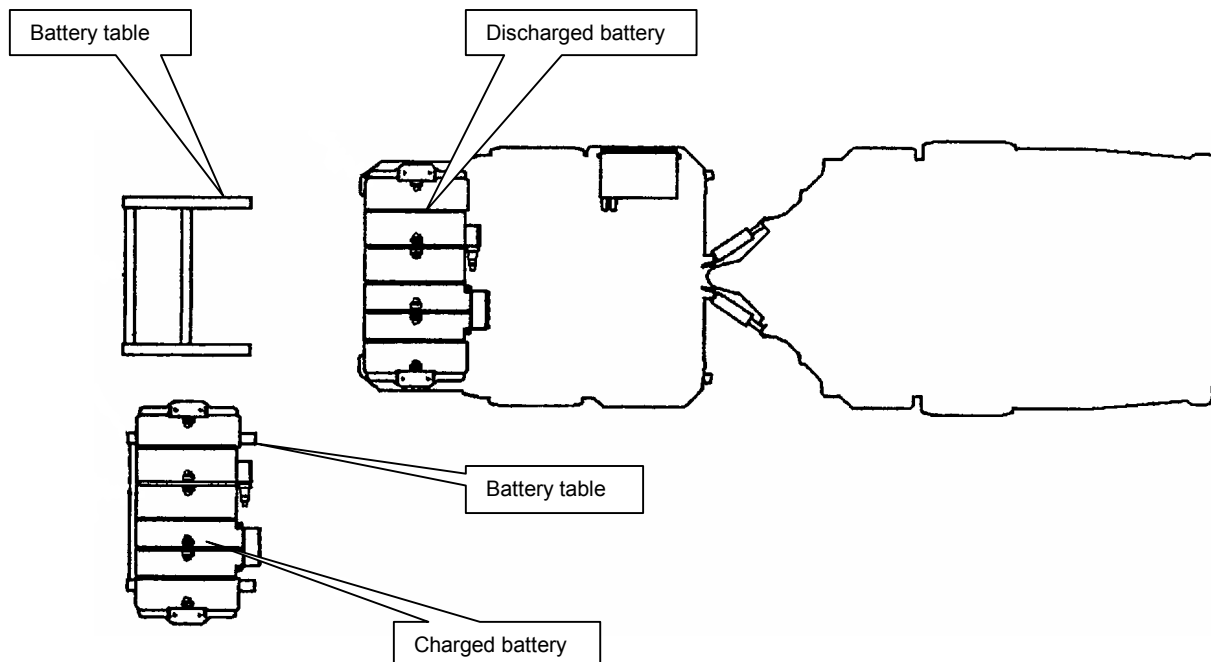
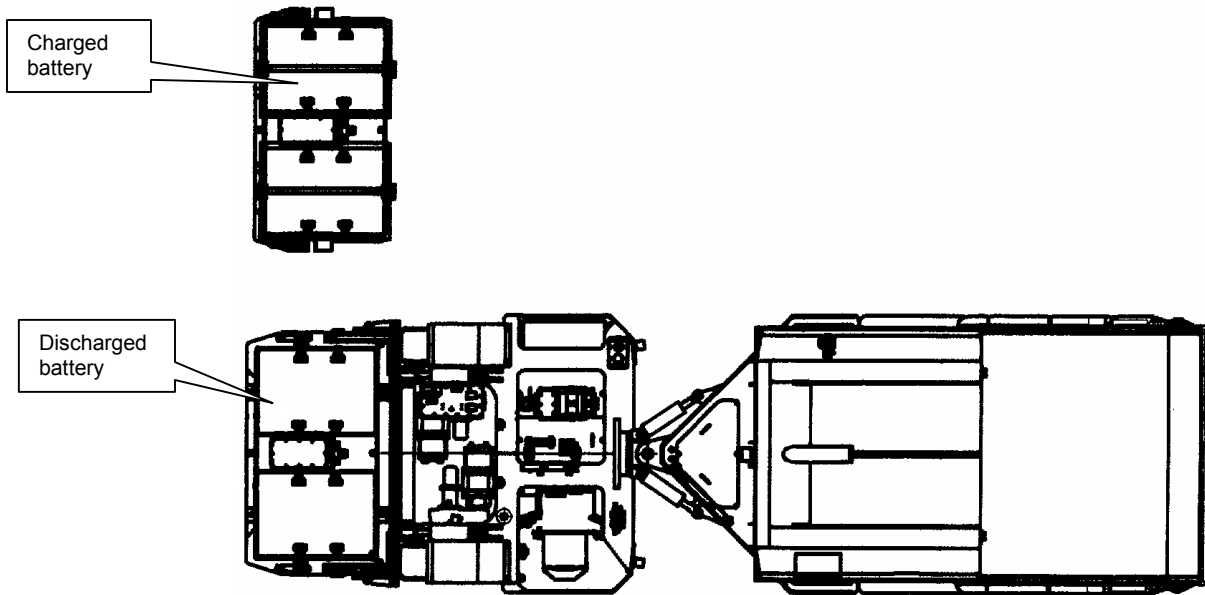

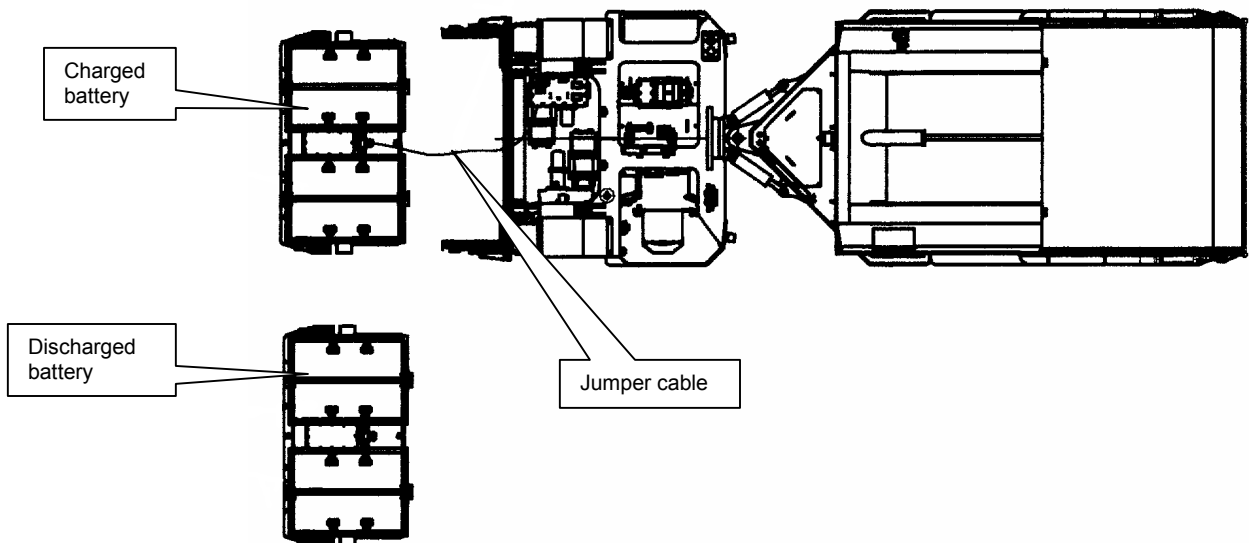

Fig. 37: Battery change procedure (CH818 ground level)



- ☞ Start the UN-A-HAULER® (see Starting procedure in this chapter). Gently pull away from the discharged battery while the second person holds the jumper cable away from possible damage.
- ☞ Line the UN-A-HAULER® up with the fully charged battery. Move the machine forward until the lift arms are aligned with the sides of the battery (Fig. 38). Continue moving forward until the lift arms are in correctly aligned under the slots in battery.

Fig. 38: Battery change procedure (CH818 ground level)



CLICK HERE TO **DOWNLOAD** THE COMPLETE MANUAL

- Thank you very much for reading the preview of the manual.
- You can download the complete manual from: www.heydownloads.com by clicking the link below



- Please note: If there is no response to CLICKING the link, please download this PDF first and then click on it.

CLICK HERE TO **DOWNLOAD** THE COMPLETE MANUAL



Critical torque values

Torque values are expressed in lubricated and dry thread values. Lubricated thread torque values should be used any time the bolt threads are covered with oil, grease, anti-seize or thread-locking compounds. Dry thread torque values should be used when threads are completely clean and dry.

Table 1: Critical torque values

Location	Bolt size	Grade	Dry	Lubricated
Steering cylinder pins			400	240
Tire-Wheel mounting bolts (Front)	3/4-16UNF X2-1/2	Grade 8	420	250
Tire-Wheel mounting bolts (Rear)	3/4-16UNF X2	Grade 8	420	250
Planetary wheel end-to-frame mounting bolts	3/4-NC 3-1/4	Grade 8	380	230
Gear case-to-frame mounting bolts	3/4-NC 2-1/4	Grade 8	380	230
Drive motor-to-gear case mounting bolts	3/4-NC 2-3/4	Grade 5	380	230
Center section (Outer ring) (810 & 816) * See note 1	7/8-NC 9	Grade 8	650	N/A
Center section (Inner ring) (810 & 816) * See note 1	1 1/4 NC 9	Grade 8	1886	

Notes:

- Retorque of these bolts should not be required due to the use of prevailing torque locknuts. If bolts require to be retorqued, new bolts and locknuts must be installed.

Lubricants, fluids and capacities

Table 2: Lubricants, fluids and capacities

Location	Specification	Approximate capacity	Notes
Hydraulic oil	Spec. 100-1	72 Gallons (816 and 818) 65 Gallons (810)	1
Drive sump (Gear case)	Spec. 100-8	4 Gallons Each	2, 3
Multi-Purpose grease	Spec. 100-3	As Required	4

Notes:

- With false bottom/ejector blade completely retracted.
- 4 gallons of oil to completely fill dry system. Actual level should be checked after running unit to fill cooling system. Use dipsticks (one in each drive gear case) to check oil level.
- Drain gear case and wheel end separately. Fill gear case only to proper level on dipstick.
- Pump grease into fitting until old grease can be observed coming out of component.



gear cases and planetary wheel ends

Change the oil in both gear cases and planetary wheel ends after the first week of service (Fig. 60).

- ☞ Remove the drain plug (or hose connection if equipped with rear tractive assist) from the gear case and from the planetary wheel end and allow the oil to completely drain.
- ☞ Replace the drain plugs and refill with oil to full level on dipstick or until oil begins to flow from check/level plug.

Fig. 60: Gear case and planetary wheel end lubrication

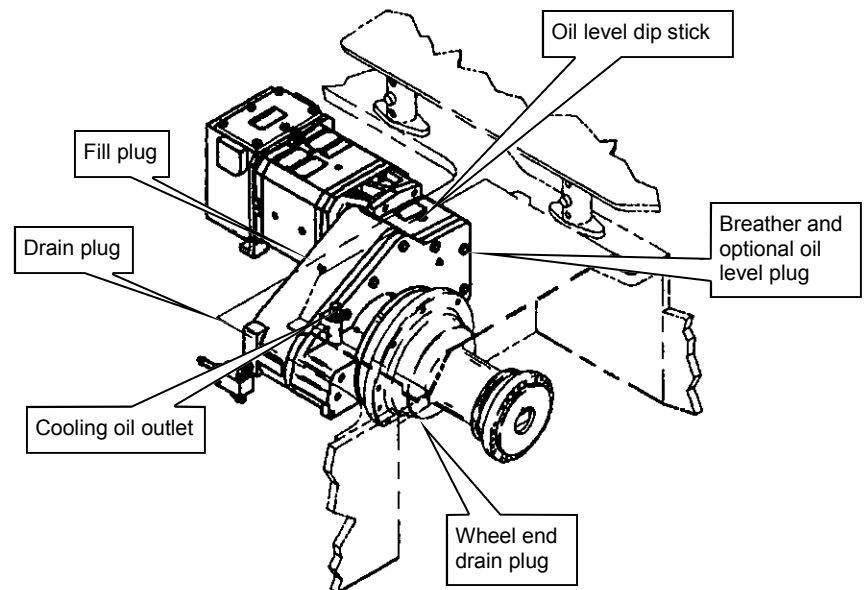

wheel mounting bolts

Check the wheel mounting bolts (Fig. 61). The mounting bolts should be torqued to 300 ft-lbs on the Model 810 and to 380 ft-lbs on Models 816 and 818. Use Loctite 242 on wheel mounting bolts.

Fig. 61: Wheel mounting bolts

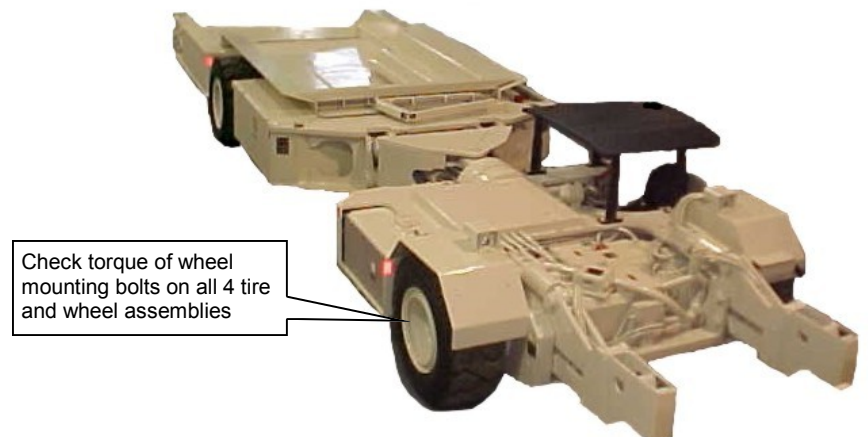



hydraulic oil suction strainer

Clean or replace the hydraulic suction strainer inside the hydraulic oil tank (Fig. 74).

- ☞ Remove the drain plug from the hydraulic oil tank to allow the oil to drain.
- ☞ Remove the oil tank cover and gasket.
- ☞ Reach through opening in tank and unscrew strainer from fitting.
- ☞ Replace the strainer with a new one or thoroughly clean the old one with kerosene and a soft brush. Dry the cleaned strainer with air before replacing in the tank.
- ☞ Replace the strainer in the tank and tighten hand-tight.
- ☞ Inspect cover gasket for damage and replace if necessary.
- ☞ Replace cover and gasket,
- ☞ Install drain plug.
- ☞ Refill tank to proper level with hydraulic oil (Spec. 100-1).
- ☞ Purge hydraulic system of air.

Fig. 74: Hydraulic oil suction strainer maintenance

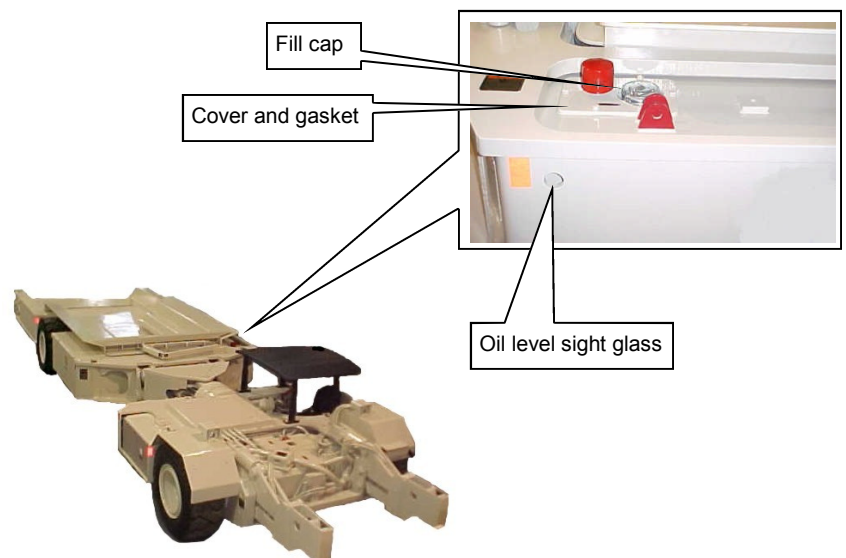



Brake cooling circuit relief pressure adjustment

To adjust the steering relief pressure proceed as follows (Fig. 84).

- ☞ Raise and securely block the machine off the ground so that all four (4) wheels are free to rotate.



DANGER!

You could be seriously injured or even killed by falling loads. Observe the safe working load of the lifting and blocking devices and keep a safe distance away from suspended loads.

- ☞ Remove the hose fittings from the top of the relief valve.
- ☞ With a gauge and suitable fittings, install the gauge onto the relief valve where the hose was disconnected.
- ☞ Start the machine, release the automatic brakes and slowly depress the accelerator pedal.
- ☞ As the drive wheels begin to turn, read the pressure indicated by the gauge. The pressure should be 50 psi. If the pressure is not 50 psi, continue to next step.
- ☞ Remove the cap that covers the pressure adjustment screw.
- ☞ Using an allen wrench, turn the screw until the correct pressure of 50 psi is indicated on the pressure gauge.
- ☞ Replace the cap on the relief valve.
- ☞ Remove the gauge and replace the hose in the relief valve.

Fig. 84: Brake cooling circuit relief pressure adjustment

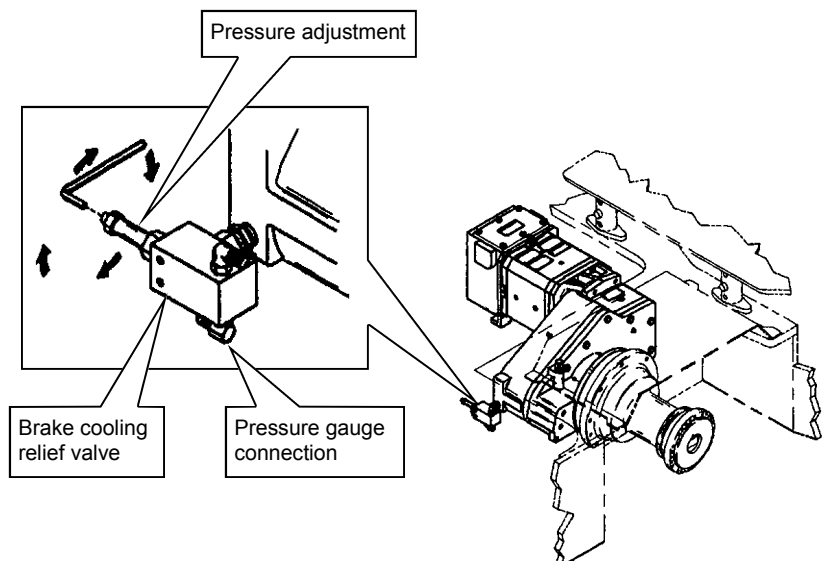



Tailgate sequence valve adjustment (P/N LUP02119)

To adjust the tailgate sequence valve proceed as follows (Fig. 88 and 89).



WARNING!

Before moving the “EJECTOR” control lever, always check to make sure no one has any part of their body between the ejector blade/false bottom and the front of the rear (payload) section.



IMPORTANT!

Remember that counterbalance cartridges adjust opposite of relief cartridges. Turning the stem clockwise will reduce pressure.

The cartridges on the sequence valve are identified with numbers stenciled on the valve body beside the location of the respective cartridge.

- ☞ Ensure that the “SYSTEM PRESSURE” is set as specified on the hydraulic schematic supplied with your machine before beginning this procedure.

Extend cycle

Cartridges #3 and #4 should be minimized (Turn adjustment stem out in a counter-clockwise direction), prior to operating the Extend Cycle. These two cartridges control the sequential operation of the extend function and should prevent any movement of the false bottom or ejector, until the tailgate is fully open. Cartridge #3 controls oil flow to the false bottom cylinders extend ports and Cartridge #4 controls oil flow to the ejector extend port. If adjustment is required, proceed as follows:

- ☞ If the false bottom or ejector cylinders are extending while the tailgate is being opened, increase the setting of Cartridge #3 first, in full turn increments (Turn adjustment stem in clockwise), to inhibit any movement of the false bottom and ejector cylinders until the tailgate is fully opened. Once this is achieved, you may optimize the cartridge setting by decreasing the adjustment (Counter-clockwise direction) in fractional increments (e.g. 1/2hf; 1/4tr; 1/8th turns) to insure that the transition between functions is as smooth as possible. At this point, you may have to increase the adjustment of Cartridge #4 in like fashion to insure that the false bottom reaches full extension before the ejector will move. Again, you should optimize the cartridge setting for the ejector control to insure that the transition between functions is as smooth as possible.



IMPORTANT!

Insure that all the jam nuts have been locked down securely before returning the machine to service, to insure that the cartridge settings will be maintained.



Drive motor/ gear case removal and replacement



WARNING!

Power must be removed by unplugging the battery plug before servicing the motors.

drive motor removal

- ☞ Disconnect the power cables to the motor. Unpack the motor gland and completely remove the wiring and conduit from the motor.
- ☞ Attach a crane or hoist, capable of lifting the motor, to the eyebolt (Fig. 92) on top of the motor and take up any slack in hoist chain.
- ☞ Remove the four bolts that attach the motor to the gear case. Access holes are provided in the frame to the bottom motor bolts. Cover the reducer opening to prevent foreign matter from entering the gear case.
- ☞ Lift the motor out of the unit.

Fig. 92: Drive assembly component removal

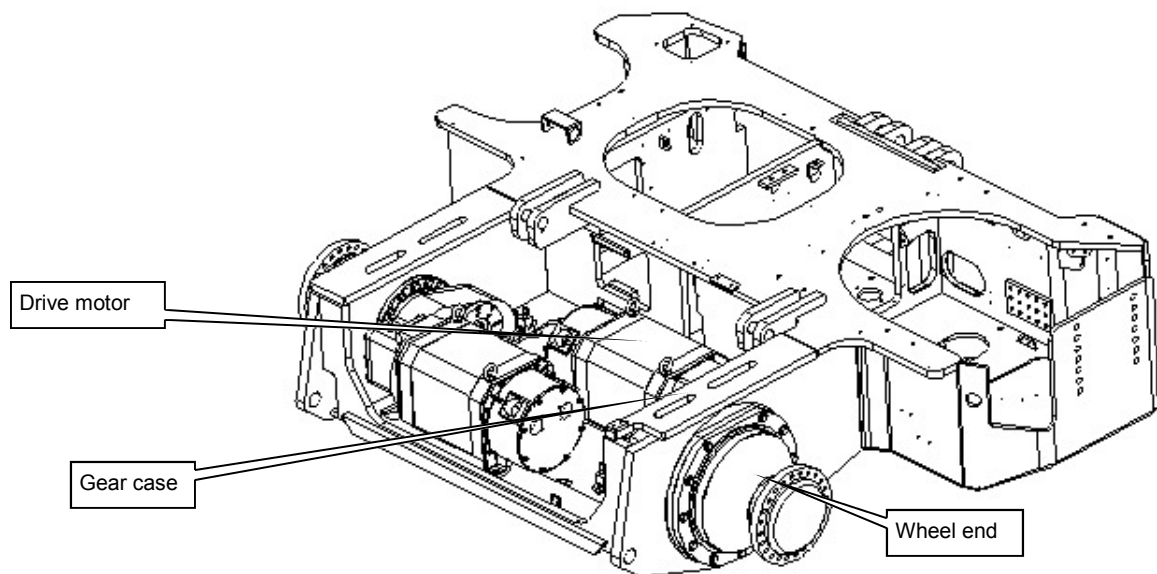

drive motor replacement

- ☞ Verify that motor pinion gear is installed.
- ☞ Clean all mating surfaces (motor and gear case.)
- ☞ Lower motor into unit and align bolt holes.
- ☞ Bolt motor onto gear reducer turning pinion gear as necessary to align gears.



False bottom/ejector cylinder replacement



WARNING!

Because you will be working in between the false bottom and the front of the rear (payload) section, you must completely shutdown the unit (see shutdown procedure) and disconnect the battery plug to prevent accidental movement of the false bottom.

to remove false bottom

The ejector blade/false bottom assembly is operated by three hydraulic cylinders - one on the ejector blade and two on the false bottom.

- ☞ Extend false bottom to within 152 mm to 304 mm from the end of the machine (by hand if necessary).
- ☞ Shutdown the machine.
- ☞ Remove false bottom cylinder covers.
- ☞ Remove bolts (4 each) from false bottom cylinder clevis (2) located in outer end of false bottom.
- ☞ Start-up machine and fully extend false bottom cylinders. (Note: Be sure all persons are away from the false bottom before start-up). The cylinders will push out the clevises out from the false bottom exposing the pins.
- ☞ Shutdown the machine.
- ☞ Remove pins from rod end clevis that are now exposed.
- ☞ Start up machine and retract false bottom cylinders.
- ☞ Shutdown machine.
- ☞ Remove cylinder end pins and remove false bottom cylinders.



NOTICE!

A "port-a-power" unit can be used to press the cylinder end pins out from the false bottom cylinders by inserting the unit between the rear section frame and the pin.

Replacement of wear parts



PRECAUTIONS:



WARNING!

Do not install or remove tire/wheel assemblies from a machine without proper training.



WARNING!

Check wheel components periodically for cracks or broken parts. Replace all cracked, badly worn, damaged or severely rusted components. When in doubt replace.



WARNING!

Do not, under any circumstances, attempt to rework, weld, heat or braze any wheel components that are cracked, broken or damaged. Replace such components with new OEM parts of the correct size and type.



WARNING!

Mixing wheel parts of different design or from a variety of sources is potentially dangerous.



WARNING!

Replace broken studs and each unbroken stud next to the broken one.



WARNING!

Replace all damaged wheel studs or bolts.



Components of the CH816LB UN-A-HAULER ®

Technical data sheet

general	Overall length:	approx. 38' 4"
	Overall width tractor (extended deck option):	approx. 11' 2"
	Overall width trailer:	approx. 10' 8"
	Wheelbase:	approx. 19' 3"
	Weight (empty less battery):	approx. 54,300 lbs
	Weight (w/64-SS100-25 battery):	approx. 71,480 lbs
	Design gross vehicle weight:	approx. 107,480 lbs
	Component load capacity (max.):	approx. 36,000 lbs
	Cubic feet capacity (max. payload—calculated) (w/no sideboards or tailgate) (heaped):	approx. 565 ft ³
	(struck):	approx. 365 ft ³
	Ground clearance (with 38" tires):	approx. 9.5"
	Canopy height (min) (with 38" tires):	approx. 42.5"
	Trailer height (with 38" tires):	approx. 42.5"
	Frame height (with 38" tires):	approx. 35.5"
performance	Turning radius: (machine is designed to make a 90° turn in a 16.5' entry)	
	Steering articulation:	110° total
	Tram speed: (speed will vary depending gear box ratios):	approx: 0-5 mph
	Discharge time:	approx: 25-30 seconds
	Terrain compensation articulation:	approx: (+) 10° approx: (-) 10°

Table 13: Extreme pressure gear oils (Spec. 100-2)

	Supplier	Brand name
1	Amoco Oil Company	Amoco Permagear EP 460
2	Gulf oil	EP Lubricant HD 460
3	Mobil Oil Corporation	Mobil Gear 634 Mobil Gear 636
4	Chevron U.S.A.	Chevron Gear Compound EP ISO 460
5	Sun Oil Company	Sunep 460
6	Unocal 76	Extra Duty NL Gear Lube 7 EP Extra Duty NL Gear Lube 8 EP
7	Shell Oil company	Shell Omala 680
8	Century Lubricating Oils, Inc.	Hulbest EP-7 Powergear 460
9	Texaco Lubricants Company	Meropa 680
10	Exxon	Spartan EP 460
11	Pennzoil	Super Maxol EP 460 Gear Lube Super Maxol EP 460 Gear Lube
12	Lubricating Engineers	608 Almosal Vari-Purpose Gear Lubricant
13	Conoco Inc.	Gear oil 460
14	Hydrotex	933 Industrial Gear Lubricant
15	Phillips	All Purpose Gear Oil 85W-90 5EP
16	Miners Oil	Gear Oil EP460

CLICK HERE TO **DOWNLOAD** THE COMPLETE MANUAL

- Thank you very much for reading the preview of the manual.
- You can download the complete manual from: www.heydownloads.com by clicking the link below



- Please note: If there is no response to CLICKING the link, please download this PDF first and then click on it.

CLICK HERE TO **DOWNLOAD** THE COMPLETE MANUAL