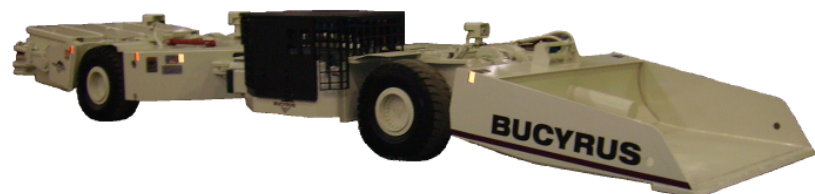




# Operation Manual

**Bucyrus - UN-A-TRAC®**  
**Models - 488L and 488-6**

**Doc. No.: A6474X235**



**Bucyrus America, Inc.**

4041 Wurno Road  
Pulaski, VA 24301

Telephone: 540-980-4530  
Fax: 540-994-3763

Internet: [www.bucyrus.com](http://www.bucyrus.com)

CLICK HERE TO **DOWNLOAD** THE COMPLETE MANUAL

- Thank you very much for reading the preview of the manual.
- You can download the complete manual from: [www.heydownloads.com](http://www.heydownloads.com) by clicking the link below



- Please note: If there is no response to CLICKING the link, please download this PDF first and then click on it.

CLICK HERE TO **DOWNLOAD** THE COMPLETE MANUAL

---

# 2 Your safety





### **maintenance, repair**

Only persons who have and can demonstrate a special knowledge of hydraulics are allowed to work on the hydraulic system.

Avoid, whenever possible, servicing, cleaning or examining the machine in congested areas.

Avoid, whenever possible, servicing or providing maintenance to the unit unless the wheels are chocked and steering lockout device is connected to prevent accidental movement of the unit.

Do not alter the electrical or hydraulic settings from that indicated in this manual or as set at the factory.

Always replace damaged or lost decals and metal instruction plates.

Disconnect the battery when working with the electrical system, or when welding on the unit to prevent electrical shock.

Be sure the battery area is well ventilated (clear of fumes) when it is necessary to connect battery charger. Fumes from the battery could ignite from a spark and explode.

Always follow all safety procedures of each particular mine when performing maintenance.

It is important that any procedure not specifically recommended in this guide be thoroughly evaluated from the standpoint of safety before it is implemented.

Some illustrations in this manual show guards or cover panels removed for purposes of clarity. Never operate unit without guards or cover panels in place.

Carry out a visual inspection of all the hydraulic components at regular intervals. In particular check that:

- the hoses are not pinched or trapped,
- the hoses have no bubbles or blisters,
- the hose or outer sheathes of the hose are not abnormally rigid or hard,
- the outer sheath of the hoses is not damaged,
- the connectors are securely inserted into the sockets, and
- the connections are leak-tight.

Ensure that no dirt enters the hydraulic system during repair work. Dirt in the hydraulic system can cause serious damage in the whole system! Flush out the hydraulic lines thoroughly before connecting.



### **WARNING!**

Power must be removed by unplugging the battery plugs before servicing the motor.

### **WARNING!**

Mixing parts of different designs or from a variety of sources for wheels with pneumatic tires could cause severe injury or death.

## Chapter 6: Technical data



### **IMPORTANT!**

Due to the application of fasteners being subject to great stresses and heavy or extreme vibration, it is imperative that all bolts be applied with an adequate amount of torque. For this reason this list of recommended torque settings for different types and sizes of fasteners used has been compiled. The tightening torques stated in the spare parts lists have to be observed, as well, for installation and maintenance.

### **NOTICE!**

Use only lubrication fluids and greases approved by Bucyrus America, Inc. ! These fluids and greases have been tested at Bucyrus America, Inc. and guarantee reliable operation of the mechanical and hydraulic functions of the machine.



### **IMPORTANT!**

The lubrication fluids and greases listed in the same table can be mixed. Other products may only be used if the supplier can guarantee that they are equivalent. Differently composed fluids and greases must not be mixed as this may change the consistency, i.e. the mixture can become thinner so that the lubrication effect is not sufficient. It may also be dangerous to use lubricating greases and fluids having the same specification base but different origins. In case of doubt, the manufacturer of the lubrication to be used should be contacted as to the compatibility of the lubrication in question.



### **IMPORTANT!**

Bucyrus America, Inc. expressly point out that the approval of the listed products relates only to the pure technical use in our mechanical and hydraulic systems. The responsibility for the constituents used in the hydraulic concentrates lies solely with the respective manufacturer.

### **NOTICE!**

When performing maintenance on the machine, all used oil and lubricants should be disposed of per your local EPA standards.



# Installation

## Points to observe prior to installation

### Who is allowed to carry out installation?

Installation is only allowed to be carried out by personnel having received adequate training to perform this task.

Work on:

the safety components (pressure relief valves, fire extinguishing equipment etc.),

the electrical equipment (control units, signaling devices, etc.), and

the hydraulic equipment (cylinders, directional control valves, hoses etc.)

should only be carried out by Bucyrus America, Inc. service engineers or by specially trained personnel.

### Which tools are required for installation?

#### tool box

No special tools are required to put the UN-A-TRAC® into service.

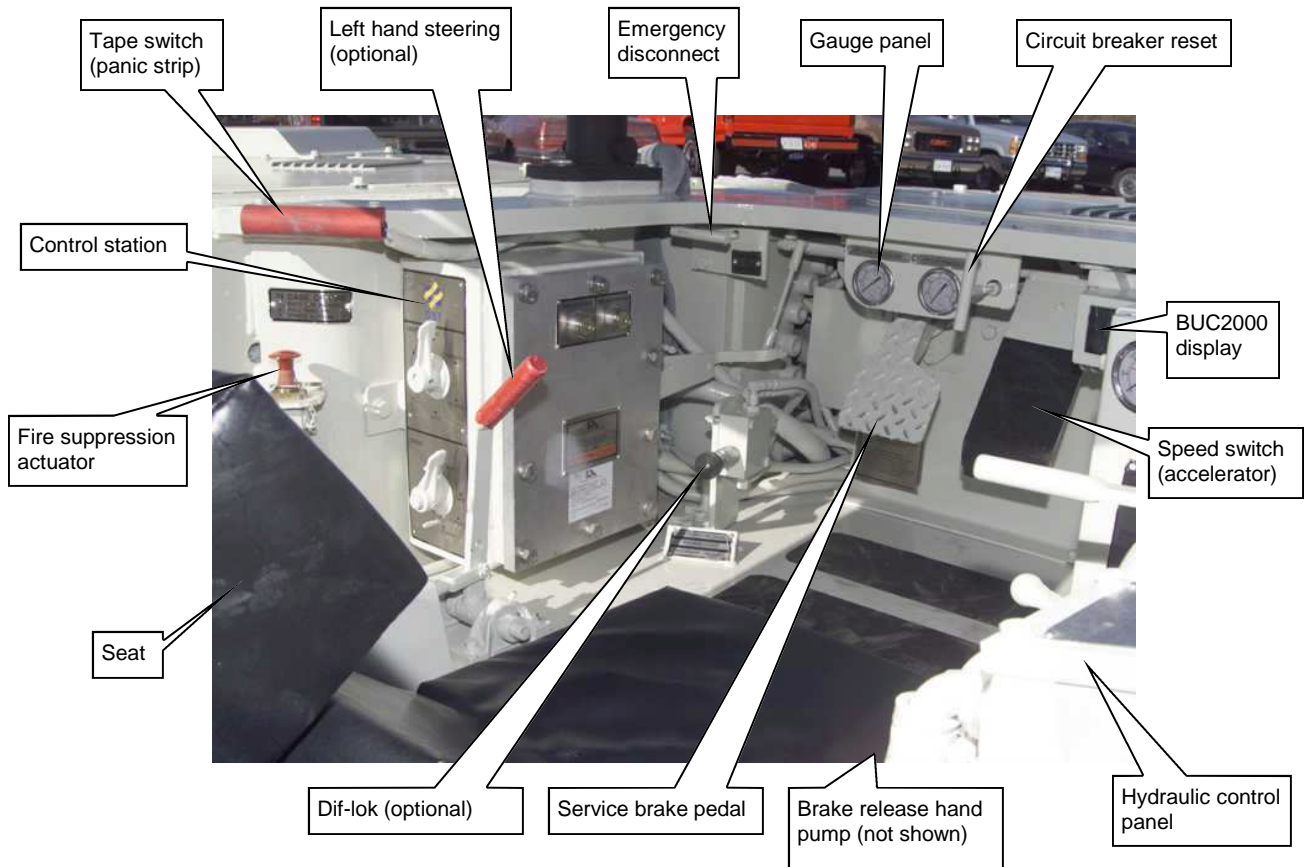
The battery plugs and receptacles come with a special wrench for connecting and disconnecting battery plugs and receptacles.

Various items of auxiliary equipment and machines may be required at the point of installation. These include:

- hoists with adequate lifting capacity
- means of attachment with adequate lifting capacity
- unloading dock
- jacks with adequate lifting capacity



Fig. 9: Operator's compartment with control station



© BUCYRUS AMERICA, INC.

Note:  
Typical operator's compartment shown, location of controls may vary.

**WARNING!**

Before operating any levers or pedals on the UN-A-TRAC® always make sure no one is in the hazard zone (see Hazard zone in this chapter). Do not operate any levers or pedals from outside the operator's compartment.

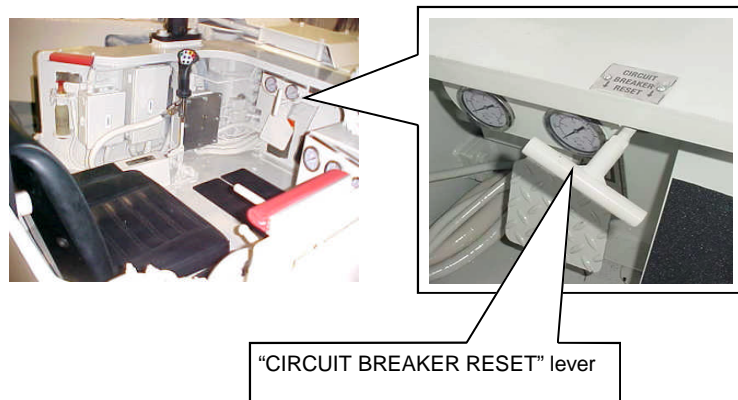


**Operator’s compartment - control handle model only**

**“CIRCUIT BREAKER RESET” lever**

The “CIRCUIT BREAKER RESET” lever (Fig. 18), located in front of and to the right of the operator, is used to reset the connection box (batteries) breaker when it has tripped. This circuit breaker is located in the connection box in the rear section of the UN-A-TRAC®. If the breaker has tripped, the reset lever must be pulled all the way out to the “RESET” position first and then pushed in to the “ON” position.

**Fig. 18: “CIRCUIT BREAKER RESET” lever**



**WARNING!**

The circuit breaker de-energizes the electrical controller and motors. However, electrical power is still present inside the connection box to the circuit breaker. If the circuit breaker inside the connection box requires service, the battery plugs must be disconnected from the batteries.

The circuit breaker is not intended as an "ON-OFF" switch for normal operation. Except in an emergency, the UN-A-TRAC® should be SHUTDOWN by first moving the master switch to the "OFF" position and then moving the circuit breaker to the "OFF" position.

**WARNING!**

The circuit breaker should be in the “OFF” position and the parking brake set before the operator leaves the operator’s seat. In an emergency, the operator can stop the UN-A-TRAC® by striking the tape switch (panic bar), which trips the circuit breaker. The machine can also be stopped by moving the circuit breaker lever to the “OFF” position.

**Control handle**



**IMPORTANT!**

For more detailed control handle operating instructions, see Starting procedures in this chapter.

The control handle (Fig. 19) located to the left of the operator has a group of switches that control the following:

**“TRACTION ASSIST”**

Press down for Traction Assist.



## Shutdown procedure with control handle

Tram the UN-A-TRAC® to its designated parking place.

Stop the UN-A-TRAC® by releasing the speed-switch foot pedal and depressing the foot brake pedal. When the speed-switch foot pedal is released, the tram (traveling) motors will stop. Applying the foot brake will stop forward (or reverse) motion. The hydraulic pump's electric motor will still be running, making a whining sound.

- ☞ 1. If equipped with optional quick attach bucket, ensure that the bucket (or other attachment) is lowered to the surface and ejector blade is returned to the back of the bucket. There should be no obstructions between the back of the bucket and ejector blade.

### WARNING!

**If equipped with optional quick attach bucket or other attachment, ensure that the bucket or attachment is lowered to the surface and ejector blade is returned to the back of the bucket. Always check before moving the ejector blade control lever to make sure no one has any part of their body between the ejector blade and the back of the bucket.**

Note: Refer to Fig. 24 for illustration of control handle.

- ☞ 2. Before leaving the operator's compartment, press J3" to turn "OFF" the machine.
- ☞ 3. Turn "OFF" the machine circuit breaker.
- ☞ 4. Turn "OFF" battery circuit breaker and/or disconnect switch (if equipped) before leaving the machine area.
- ☞ 5. Connect the steering lockout device (Fig. 25):
  - remove the steering lockout device from its storage lugs
  - remove the hitch pin from the end farthest from the center section
  - adjust turnbuckle until holes line up between the turnbuckle lug and the front section lug
  - insert the hitch pin into the front section lug through the turnbuckle

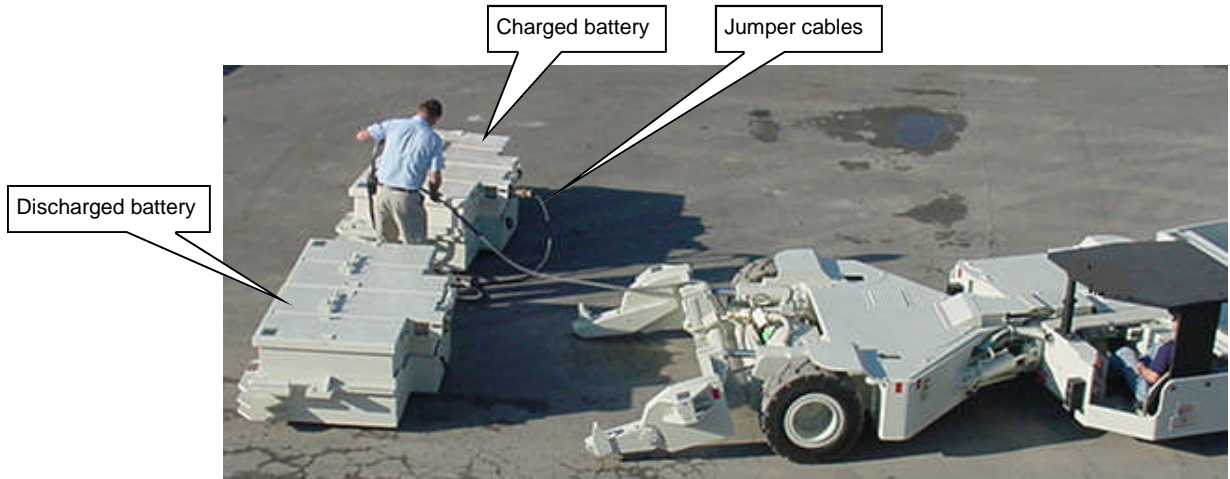
### WARNING!

**Never enter the articulation area while the machine is running. Completely shutdown the machine as outlined before connecting the steering lockout device. Failure to observe this precaution may result in injury or death.**



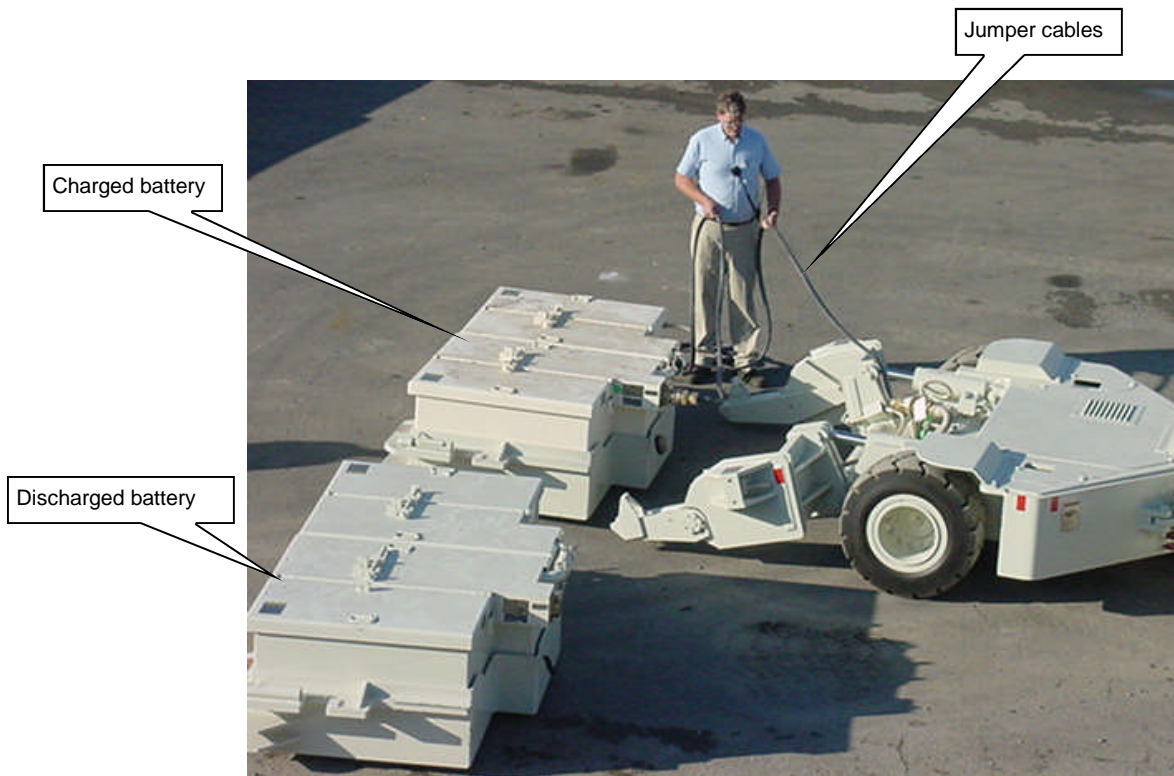
- ☛ Start the UN-A-TRAC® (see Starting Procedure in this manual). Gently pull away from the discharged battery while the second person holds the jumper cables away from possible damage (Fig. 30).

**Fig 30: Battery changing procedure (ground level)**



- ☛ Line the UN-A-TRAC® up with the fully charged battery. Move the machine back until the lift arms are aligned with the sides of the battery (Fig. 30 and 31).

**Fig. 31: Battery changing procedure (ground level)**





## Instructions on the maintenance

Maintenance at regular intervals increases the operational safety and prolongs the service life of the machine. In particular, observe the safety instructions in chapter 2 “Your safety”.

### Important notes

Please observe the following:

- In order to avoid individual components not being serviced or being only inadequately serviced during maintenance work on the machine as a whole, we recommend that a general maintenance plan be drawn up. You can, for example, draw up a checklist using this operation manual and the manuals of the other components.
- Inadequate maintenance can result in machine damage which leads to considerable costs.
- Use only suitable and approved tools for maintenance work.
- Use only original Bucyrus spare parts when replacing components.
- All electrical work must be supervised and inspected by a certified electrician.
- Anyone performing maintenance on this equipment must be trained to operate it and be familiar with this Bucyrus America, Inc. guide.

### Before maintenance

Please observe the following:

- Shutdown the machine on level ground.
- Disconnect the electrical power. Either the battery circuit breaker or the emergency manual power disconnect (if equipped) must be in the "OFF" position. If work is to be done inside the electrical controller, the battery should be disconnected. Also make sure the capacitor discharge module indicates that the capacitors are discharged before working inside the controller.

#### **WARNING!**

**Before performing maintenance on the machine, disconnect the electrical power. Either the battery circuit breaker or the emergency manual power disconnect (if equipped) must be in the "OFF" position. If work is to be done inside the electrical controller, the battery should be disconnected. Also make sure the capacitor discharge module indicates that the capacitors are discharged before working inside the controller. Electrical shock and accidental machine movement can cause serious injuries or even death to you or the maintenance person.**



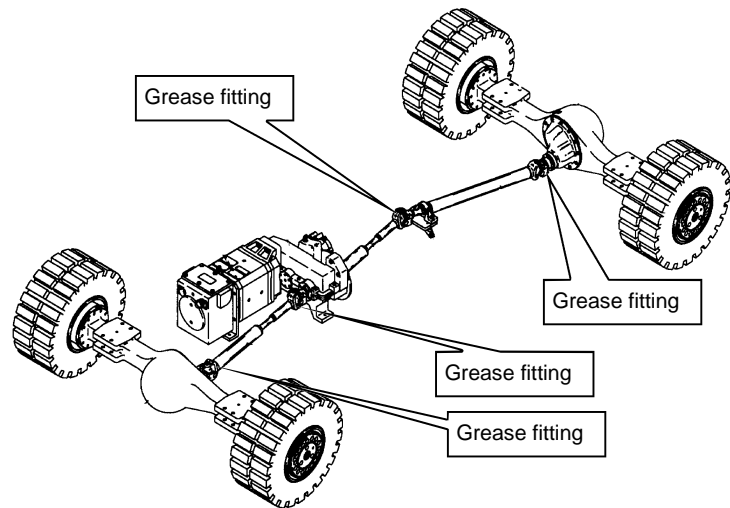
**winch guide rollers (if equipped)**

Lubricate the winch guide rollers (if equipped) (6 places) with Spec. 100-3 through the grease fittings located on each roller. Pump grease into the fittings until new grease can be observed coming out of the roller.

**front and rear drive lines**

Lubricate the front and rear drive lines (4 places) with Spec. 100-3 through the grease fittings located on each cross bearing (Fig. 54). Pump grease into the fittings until new grease can be observed coming out of the bearing.

**Fig. 54: Front and rear drive line lubrication points**



© BUCYRUS AMERICA, INC.

**fasteners  
(nuts, bolts and screws)**

Loose fasteners will cause premature wear and failure to machine and components. Visually inspect for loose fasteners and tighten as required.

**tire/wheel mounting bolts**

Check the wheel mounting nuts (Fig. 55). The mounting nuts should be torqued to 300 ft-lbs lubricated for a John Deere axle, 217 ft-lbs lubricated for a Kessler axle, 120 ft-lbs lubricated for an Axle Tech axle. Use Loctite 242 on wheel mounting bolts.

**Fig. 55: Tire/wheel mounting nuts**

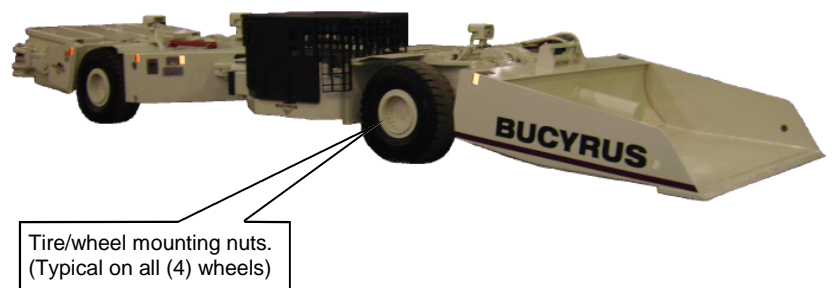




Fig. 69: Axle and wet disc brake oil level (Kessler)

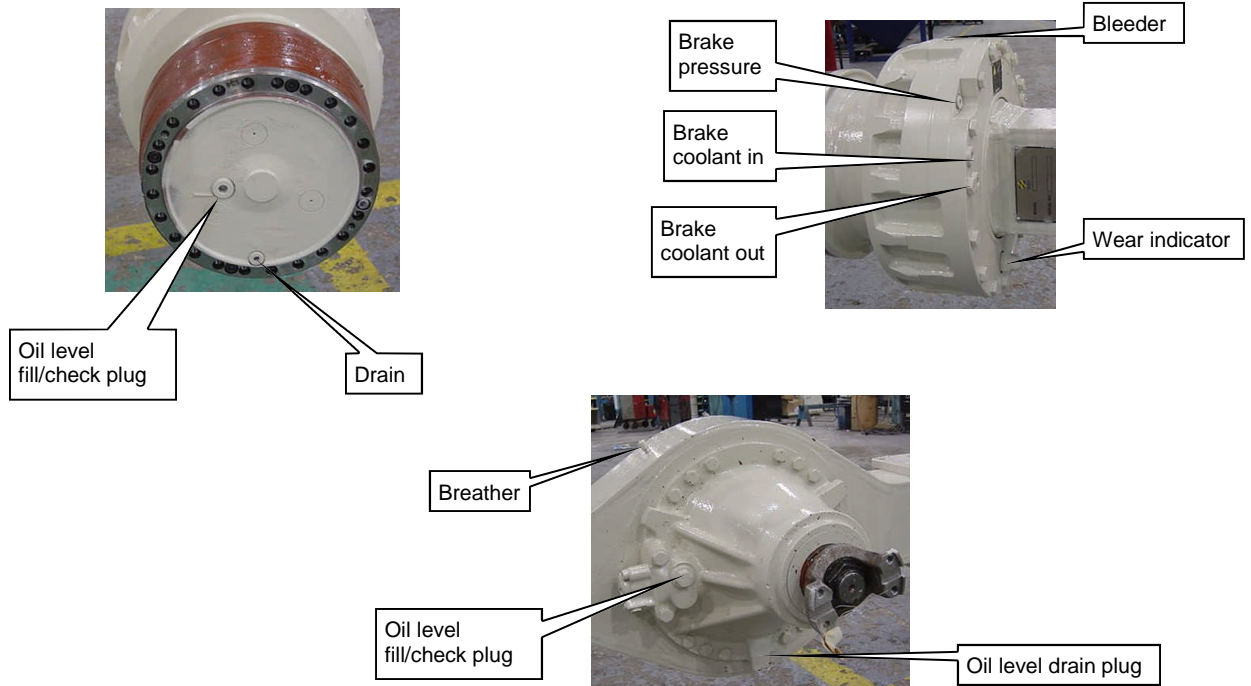
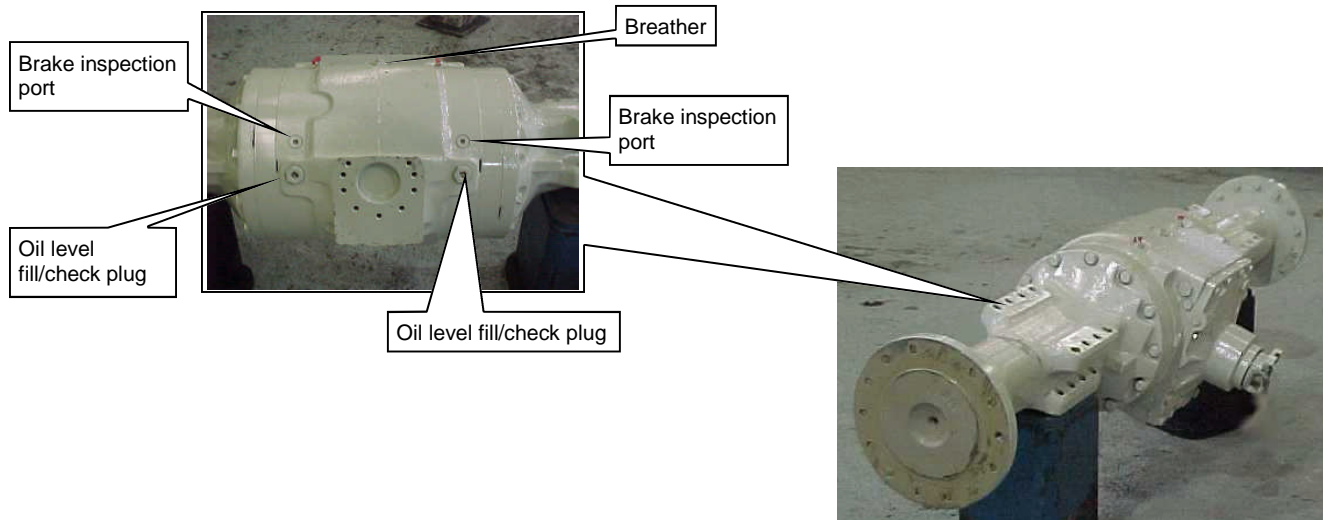


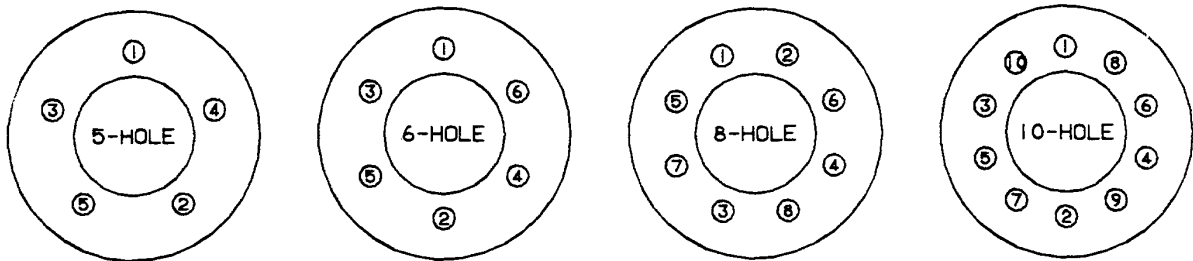
Fig. 70: Axle oil level (John Deere)



© BUCYRUS AMERICA, INC.



Fig. 79: Torque patterns



### Recommended wheel mounting procedures

- ☞ All steel mating surfaces must be free and clean of any dirt, corrosion, paint, etc. These areas include wheel/hub tapers and disc faces. **NO PAINT** should be present under bolt heads or nuts.
- ☞ Fasteners should be in proper condition. Any fastener with damage, such as corrosion, bending or worn threads, should be replaced. Replace all broken wheel studs.
- ☞ After positioning the wheel on the hub, tighten nuts down evenly. Triangulate the bolt pattern tightening sequence as shown in the diagrams.
- ☞ After operating the machine for a short period of time, check the wheel-mounting bolts or nuts for proper torque.

NOTE: Wheel bolts or nuts “seat in” during normal vehicle operation. Therefore, it is necessary to repeat torquing procedures as necessary to seat the wheel to the hub. Planned periodic checks will help maintain correct torque values. All bolts and nuts, regardless of type, should be regularly checked for tightness.

### Precautions

- Do not install or remove tire/wheel assemblies from a machine without proper training.
- Check wheel components periodically for cracks or broken parts. Replace all cracked, badly worn, damaged, or severely rusted components. When in doubt, replace.
- Do not, under any circumstances, attempt to rework, weld, heat, or braze any wheel components that are cracked, broken or damaged. Replace such components with new OEM parts of the correct size and type.
- Mixing wheel parts of different designs or from a variety of sources is potentially dangerous.
- Replace broken studs and each unbroken stud next to the broken one.
- Replace all damaged wheel studs or bolts.



Table 8 (continued): Hydraulic pump troubleshooting

Trouble, symptom or cause	Probable cause	Test, check and/or remedy
<b>seal leak (continued)</b>	<ul style="list-style-type: none"> <li>☞ Oil viscosity too high or operating temperature too low.</li> <li>☞ Air leak in suction line or fittings.</li> <li>☞ Loose or worn pump parts.</li> <li>☞ Air leak at pump shaft seal.</li> <li>☞ Oil level too low and drawing air in through inlet pipe opening.</li> <li>☞ Air bubbles in intake oil.</li> <li>☞ Pump housing bolts loose or not properly torqued.</li> </ul>	<ul style="list-style-type: none"> <li>☞ Replace with recommended oil.</li> <li>☞ Replace lines or fittings if badly worn.</li> <li>☞ Replace worn pump parts.</li> <li>☞ Replace pump shaft seals.</li> <li>☞ Check oil level.</li> <li>☞ Check oil level and tighten any loose fittings.</li> <li>☞ Tighten the housing bolts and re-torque bolts.</li> </ul>
<b>pump failure to deliver oil</b>	<ul style="list-style-type: none"> <li>☞ Low oil level in reservoir.</li> <li>☞ Oil intake hose suction strainer plugged.</li> <li>☞ Air leak in suction line and preventing priming.</li> <li>☞ Pump shaft turning too slowly.</li> <li>☞ Oil viscosity too high.</li> <li>☞ Wrong shaft rotation.</li> <li>☞ Pump shaft or parts broken.</li> <li>☞ Dirt in pump.</li> </ul>	<ul style="list-style-type: none"> <li>☞ Fill to proper level.</li> <li>☞ Clean or replace strainer.</li> <li>☞ Tighten or replace suction lines.</li> <li>☞ Gears are worn and need replacing.</li> <li>☞ Replace with recommended oil.</li> <li>☞ Check pump motor wiring.</li> <li>☞ Replace shaft or broken parts.</li> <li>☞ Clean pump .</li> </ul>
<b>oil leakage around pump</b>	<ul style="list-style-type: none"> <li>☞ Shaft seal worn.</li> <li>☞ Head of oil on suction hose connection leaking.</li> <li>☞ Pump housing bolts loose or improperly torqued.</li> </ul>	<ul style="list-style-type: none"> <li>☞ Replace seals.</li> <li>☞ Tighten bolts. Tighten or replace connections.</li> <li>☞ Tighten bolts.</li> </ul>



**Table 16: Electrically zinc plated (Coarse thread)**

Property class	Torque	Recommended torque setting			Nominal diameter			
		Ma	M33	M4	M5	M6	M7	M8
5.6	Nm	0.56	1.28	2.50	4.3	7.1	10.5	21
	Ft-lbs	0.41	0.94	1.84	3.1	5.2	7.7	15
8.8	Nm	1.28	2.90	5.75	9.9	16.5	24	48
	Ft-lbs	0.94	2.14	4.24	7.3	12.1	17.7	35
10.9	Nm	1.80	4.10	8.10	14	23	34	67
	Ft-lbs	1.33	3.02	5.97	10.3	16.9	25	49
12.9	Nm	2.15	4.95	9.70	16.5	27	40	81
	Ft-lbs	1.59	3.65	7.15	12.1	19.9	29	59

**Table 16: Electrically zinc plated (Coarse thread, continued)**

Property class	Torque	Recommended torque setting			Nominal diameter			
		Ma	M12	M14	M16	M18	M20	M22
5.6	Nm	36	58	88	121	171	230	
	Ft-lbs	26	42	54	89	126	169	
	Nm	83	132	200	275	390	530	
8.8	Ft-lbs	61	97	147	202	287	390	
	Nm	117	185	285	390	550	745	
10.9	Ft-lbs	86.2	136	210	287	405	549	
	Nm	140	220	340	470	660	890	
12.9	Ft-lbs	103	162	250	346	486	656	

**Table 16: Electrically zinc plated (Coarse thread, continued)**

Property class	Torque	Recommended torque setting			Nominal diameter			
		Ma	M24	M27	M30			
5.6	Nm	295	435	590	800	1030	1340	
	Ft-lbs	217	320	435	590	759	988	
	Nm	675	995	1350	1830	2360	3050	
8.8	Ft-lbs	497	733	995	1349	1740	2249	
	Nm	960	1400	1900	2680	3310	4290	
10.9	Ft-lbs	708	1032	1401	1902	2441	3163	
	Nm	1140	1680	2280	3090	3980	5150	
12.9	Ft-lbs	840	1239	1661	2278	2935	3798	

CLICK HERE TO **DOWNLOAD** THE COMPLETE MANUAL

- Thank you very much for reading the preview of the manual.
- You can download the complete manual from: [www.heydownloads.com](http://www.heydownloads.com) by clicking the link below



- Please note: If there is no response to CLICKING the link, please download this PDF first and then click on it.

CLICK HERE TO **DOWNLOAD** THE COMPLETE MANUAL

**Table 27: Light gear oil, SAE 40 motor oil (Spec. 100-10)**

	Supplier	Brand name
1	Amoco Oil Company	Amoco 300 SAE 40
2	Gulf Oil	Super Duty 40
3	Mobil Oil Corporation	Delvac 1340
4	Chevron U.S.A.	Chevron RPM Heavy Duty Motor Oil 15W-40
5	Sun Oil Company	Sunoco Super C 40
6	Unocal 76	Guardol Motor Oil SAE 40
7	Shell Oil Vompany	Rotella Oil 40 (Automotive) Turbo Oil 150 (Industrial) Rimula CT40 (Foreign) Rotela SX40 (Foreign)
8	Century	Flexe SAE 40
9	Texaco Lubricants Company	Ursa Super Plus SAE 40
10	Exxon	XD-3 Extra SAE 40 or XD-3 SAE 40
11	Pennzoil	Long Life SAE 40 Motor Oil
12	Lubricating Engineers	8440 Monolex GFS Engine Oil
13	Conoco Inc.	Fleet Heavy Duty Motor Oil SAE 40
14	Hydrotex	Hyfilm SAE 40
15	Phillips	Super HD II Motor Oil SAE 15W-40

**Table 28: Synthetic EP gear lubricants (Spec. 100-11)**

	Supplier	Brand name
1	Century Lubricants Company	Synthetic EP Gear Lubricants

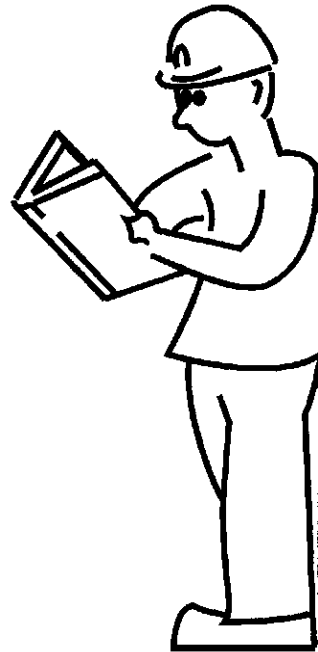
**Table 29: Multi-purpose tractor hydraulic fluid (Spec. 100-12)**

	Supplier	Brand name
1	Exxon / Mobil	Mobilfluid 424
2	Century / Fuchs	Multitran
3	Shell	Donax TD
4	Chevron	Tractor Hydraulic Fluid
5	BP Lubricants	Tractran UTH
6	Quaker State	Quaker State FCI HD
7	Conoco	Powertran Fluid

---

# 1

## About this manual





## Operating conditions

### Intended use

The battery charger has been designed and manufactured purely for the recharging of mine power storage batteries.

Intended uses include:

- the recharging of mine power storage batteries that are specified on the charger nameplate.

### Unauthorized use

Applications not expressly listed as intended uses are unauthorized uses and are not allowed to be performed with the charger.

- the recharging of other types of batteries not specified on the charger nameplate.

Bucyrus America, Inc. accepts no liability for any damage resulting from any such unauthorized use.



### Overview of the safety instructions

This is a summary of all the safety instructions which have to be observed in the following chapters. This summary is intended only to give you an overview of all the instructions. In some cases, there is no logical relationship between the individual instructions.

#### Chapter 2: Your safety

**WARNING!**

There is a risk of explosive gases and working in the vicinity of a battery is dangerous. Some batteries generate explosive gases during normal battery operation. For this reason, it is of the utmost importance that each time before using this unit, you read this manual and follow the instructions exactly.

#### Chapter 3: Storage and transport

**WARNING!**

Use only load handling devices complying with the technical and legal regulations for the transport of loads. You could be seriously injured or even killed by falling loads. Use only suitable load handling devices.

#### Chapter 4: Installation

**CAUTION!**

Serious damage can be caused to the battery charger as a result of incorrect installation. The unit should therefore only be installed under the instruction of specialists from Bucyrus America, Inc.



**IMPORTANT!**

The sequence of operations during installation must be adapted to the individual conditions prevailing at the site. Before starting the work a detailed list of steps to be taken with respect to transport and assembly should be prepared and a corresponding plan established.

**NOTICE!**

The operator must become familiar with all the safety features and their location on the machine prior to installation or operation.

**NOTICE!**

All battery chargers are shipped from the factory with the emergency stop switch disconnected. The switch must be connected and tested by the user prior to installation. When actuated, the emergency stop switch must remove all AC power from the charger.

**DANGER!**

Do not operate the machine any of the guards or covers removed. You or other personnel could be seriously injured from moving or rotating parts.



## General Information

The Bucyrus Series Mine Battery Charger combines reliable, rugged components with unmatched circuit simplicity.

The ferroresonant design of the Bucyrus Series Charger eliminates the need for complicated control circuits and lowers the parts count.

Three major components make up the circuit of the Bucyrus Series Charger: a ferroresonant step down transformer, silicon rectifiers, and a timer.

The magnetics are designed with an extra margin of capacity and have a Class H (180° C) rating.

Cores and windings are insulated with Class H Nomex material. The DuPont Nomex system uses a modified polyester baking varnish for further protection. This assures continued operation under the most severe, damp, and dirty conditions present in the mine.

The full wave rectifier includes conservatively rated silicon diodes and surge suppressers to provide a reliable DC output.

The Bucyrus Series Charger regulates the DC output voltage to produce the proper charging curves for the battery. Its charge rate is dependent on the state of charge of your battery. AC line voltage compensation prevents any drift from the DC charging curve because of surges or drops in voltage. Basic design eliminates the need for voltage sensitive relays.

The Bucyrus Series Charger automatically limits the output of the charger to approximately 125% of its rating. This prevents battery overheating and fuse blowing and assures long life for both the battery and the charger.

The Bucyrus Series Charger is a completely automatic constant voltage charger. Each Bucyrus Series Charger is designed to operate on a specific type of battery with a specified number of cells.

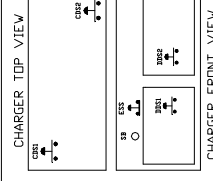
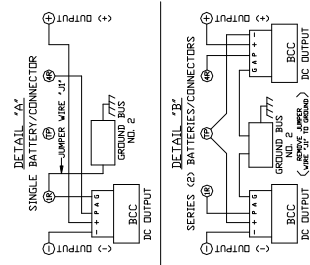
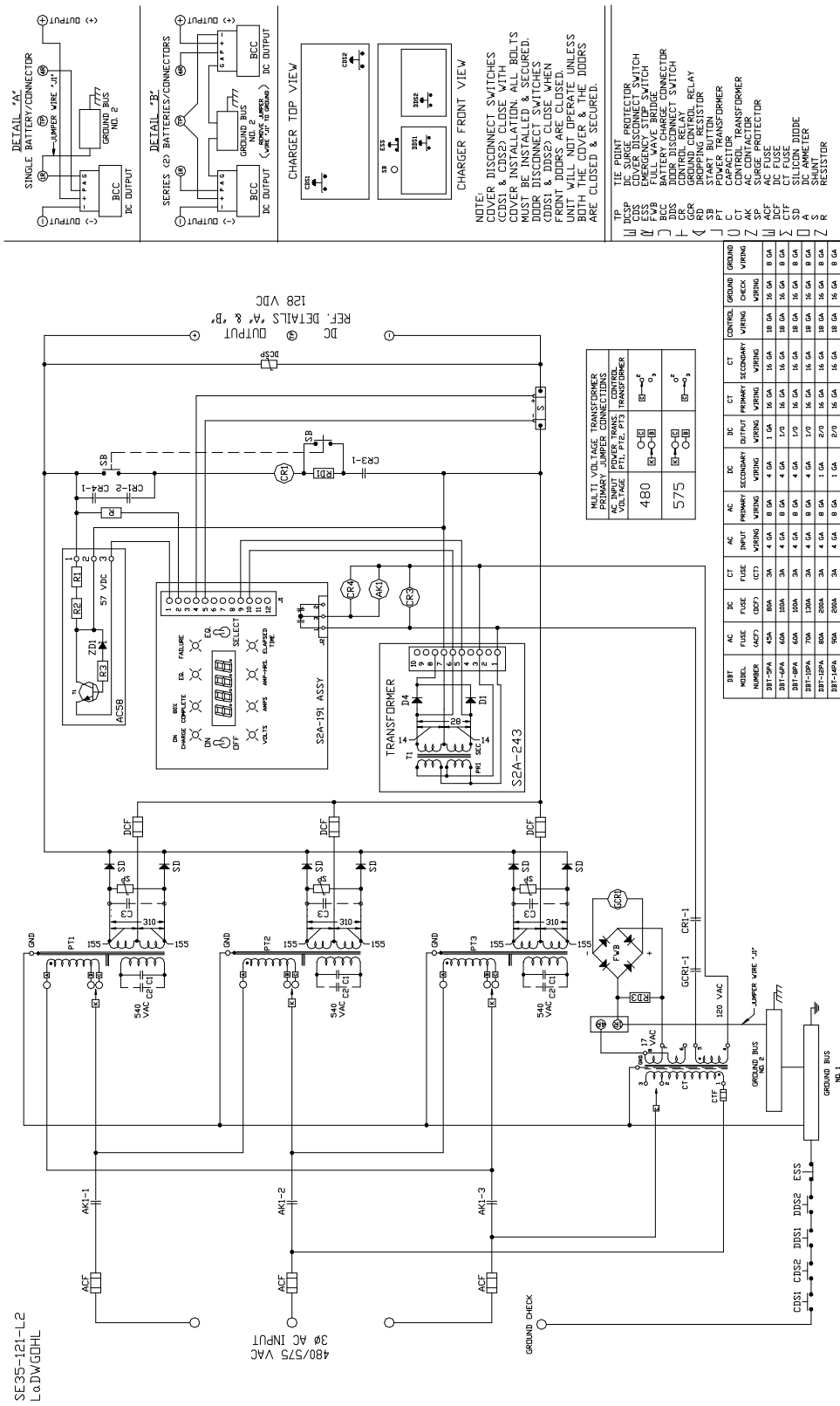
---

# 5 Operation





Fig. 6: Wiring diagram (PA models) (continued)



NOTE:  
 COVER DISCONNECT SWITCHES (CDSS1 & CDSS2) CLOSE WITH COVER INSTALLATION. ALL BOLTS MUST BE INSTALLED AND LOCKED. DOOR DISCONNECT SWITCHES (DDSS1 & DDSS2) CLOSE WHEN FRONT DOORS ARE CLOSED. UNIT WILL NOT OPERATE UNLESS BOTH THE COVER & THE DOORS ARE CLOSED & SECURED.

TP	DC SURGE PROTECTOR	ESS	EMERGENCY STOP SWITCH	FULL WAVE BRIDGE RECTIFIER	DIODE	DIODE DISCONNECT SWITCH	CONTROL RELAY	DRIPPING RESISTOR	START BUTTON	TRANSFORMER	CONTROL TRANSFORMER	SURGE PROTECTOR	AC FUSE	CT FUSE	SILICON DIODE	DIODE	RESISTOR
TP	DCSP	ESS	ESS	FWB	D	DDSS	CR	DR	SB	T	CT	SP	ACF	CTF	SD	D	R

DC OUTPUT 128 VDC  
 REF. DETAILS 'A' & 'B'

MULTI-VOLTAGE TRANSFORMERS AC INPUT POWER TRANSFORMER VOLTAGE P1, P2, P3	CONTROL TRANSFORMER
480	575

DBT	AC FUSE (ACF)	CT FUSE (CTF)	AC INPUT WIRING	AC PRIMARY WIRING	AC SECONDARY WIRING	DC INPUT WIRING	DC PRIMARY WIRING	DC SECONDARY WIRING	CT PRIMARY WIRING	CT SECONDARY WIRING	CONTROL WIRING	GROUND WIRING
DBT-5PA	45A	3A	4 GA	8 GA	4 GA	4 GA	1 GA	16 GA	16 GA	16 GA	16 GA	16 GA
DBT-6PA	60A	3A	4 GA	8 GA	4 GA	4 GA	1/2	16 GA	16 GA	16 GA	16 GA	16 GA
DBT-8PA	75A	3A	4 GA	8 GA	4 GA	4 GA	1/2	16 GA	16 GA	16 GA	16 GA	16 GA
DBT-10PA	100A	3A	4 GA	8 GA	4 GA	4 GA	1/2	16 GA	16 GA	16 GA	16 GA	16 GA
DBT-12PA	120A	3A	4 GA	8 GA	4 GA	4 GA	1/2	16 GA	16 GA	16 GA	16 GA	16 GA
DBT-14PA	150A	3A	4 GA	8 GA	4 GA	4 GA	1/2	16 GA	16 GA	16 GA	16 GA	16 GA
DBT-16PA	200A	3A	4 GA	8 GA	4 GA	4 GA	1/2	16 GA	16 GA	16 GA	16 GA	16 GA



# Technical data

This chapter contains the most important technical data on the Bucyrus Series Battery Charger with Digital Display. Further data can be found in the spare parts lists. At the end of this chapter you will find information on the bolt tightening torques. Read this chapter through carefully and pay particular attention in particular to the safety instructions.

## Components of the battery charger

### Technical data

**Part number:** 253012  
**Model:** BUC-5S  
**Output:** Single  
**Voltage/HZ:** 480/575Volt/60 HZ  
**Battery size:** 495 AH thru 550 AH  
**PA kit:** No  
**AC 110 VAC outlets:** No

**Part number:** 334140  
**Model:** BUC-5S  
**Output:** Single  
**Voltage/HZ:** 480/575Volt/60 HZ  
**Battery size:** 495 AH thru 550 AH  
**PA kit:** No  
**AC 110 VAC outlets:** Yes

**Part number:** 242657  
**Model:** BUC-5S  
**Output:** Single  
**Voltage/HZ:** 480/575Volt/60 HZ  
**Battery size:** 495 AH thru 550 AH  
**PA kit:** Yes  
**AC 110 VAC outlets:** No

**Part number:** 225465  
**Model:** BUC-6S  
**Output:** Single  
**Voltage/HZ:** 480/575Volt/60 HZ  
**Battery size:** 585 AH thru 650 AH  
**PA kit:** No  
**AC 110 VAC outlets:** No

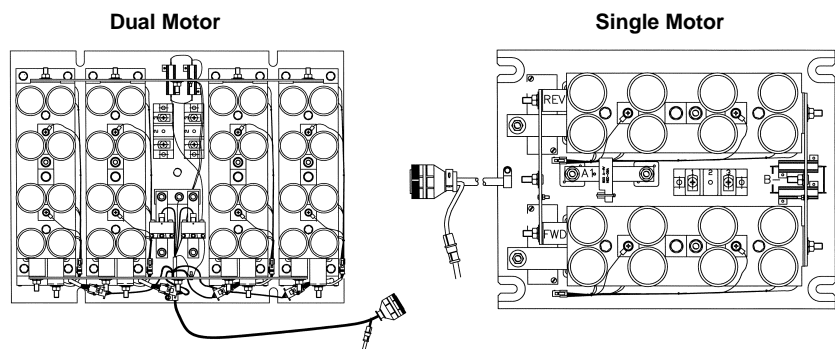


# Operation and Troubleshooting Manual

**BUCYRUS - Dual and Single  
Motor Controller**

**Model - BUC2000**

**Doc. No.: A6474X226**



**Bucyrus America, Inc.**

4041 Wurno Road  
Pulaski, VA

Telephone: 540-980-4530  
Fax: 540-994-3763

Internet: [www.bucyrus.com](http://www.bucyrus.com)

---

# 2

Your safety





# Operation

This chapter contains important information on the operation and troubleshooting of the model BUC2000 Dual and Single Motor Controller.

Read this chapter carefully and thoroughly. In particular, observe the safety instructions in Chapter 2 "Your safety".

## History

In the early 1970's, S&S Corporation lead the way in mining innovation with the introduction of solid state speed controls for battery-powered underground mining equipment. Solid state controls increased the range and reliability of the battery powered vehicles along with providing smooth, stepless acceleration. Even with solid state speed control, direction change was achieved with the use of electromechanical contactors. These contactors provided an endless source of maintenance problems and consumed excessive amounts of valuable controller-box space. Also, most solid state controllers of the past utilized an electro-mechanical "bypass" contactor to connect the motor directly to the batteries which caused more contactor problems.

In the 1980's Bucyrus America, Inc., in conjunction with Sevcon, developed a contactorless motor controller (X90) to be used exclusively on Bucyrus equipment. The X90 system used a dual-field motor in combination with SCRs (Silicone Controlled Rectifier) to achieve solid state direction change.

Now Bucyrus America, Inc., in conjunction with Sevcon, has developed the BUC2000 motor controller. The BUC2000 system uses IGBTs (Insulated Gate Bipolar Transistors) to achieve motor control and direction change. Unlike an SCR, an IGBT is turned ON and OFF via a gating electronic signal. This eliminated commutating capacitor banks and coils. The microprocessor based BUC2000 Logic Card provides complete motor control and drives both a Diagnostic Dashboard Display along with a hand held Calibrator/Diagnostic Unit.

The IGBT switch operates so fast that it can connect and disconnect the motor in less than 1/1700 second. This is such a short time period that the dual-field motor does not have time to move. Each time the IGBT switch closes and reopens, the full battery voltage is applied to the motor terminals for about 1/1700 second. This is commonly referred to as a "pulse." (Fig. 1)

The IGBT speed control works by feeding to the motor a rapid series of pulses. The number of pulses per second determines the average voltage at the motor terminals. (Fig. 2)



There is an LED on the logic card which serves as an indicator of the status of the controller. The following diagnostics shall apply:

- LED on**            Controller operational
- LED off**            Power-up fault – check display or calibrator. If all is blank, then replace logic. Check control wiring. possible shorted driver board, UVR, or “W” relay.
- 1 Flash**            **Personality CRC EEPROM Error.**  
Using the hand-held calibrator, change a password to any number then recycle power – should clear, otherwise replace logic.
- 2 Flash**            **Procedure FAULT**  
FS1 closed before power on or 2 Directional Fault. Recycle FS1 through neutral to clear.
- 3 Flash**            **IGBT permanently low (IGBT Short Circuit FAULT).**  
This includes IGBT short circuit or IGBT open circuit. This fault shuts down all modes. Recycle FS1 through neutral to clear.
- 4 Flash**            **Motor neither low nor high (Breaker Open FAULT).**  
This includes breaker open circuit or IGBT open circuit. This fault shuts down all modes. Recycle FS1 through neutral to clear.
- 5 Flash**            **Motor permanently high. (Breaker welded FAULT)**  
This includes breaker welded. This fault shuts down all modes. Recycle “KEY” to clear.
- 6 Flash**            **Faulty TRACTION accelerator.**  
Includes the accelerator greater than 15% at power on and wire-off. If wire-off occurs during active function then the motor speed will set to zero. This fault auto clears.
- 7 Flash**            **Battery voltage FAULT.**  
This includes battery below a predetermined value. Recycle FS1 through neutral to clear.
- 8 Flash**            **Thermal cut-back (Over-Temperature FAULT).**  
This includes heat sink temperature above 95° C.

**NOTICE!**

**As temperature rises above 95° C, the controller will limit the current to 300 amps (maximum), regardless of demand.**

- 9 Flash**            **UVR coil over-current FAULT (Coil short circuit FAULT).**  
Cleared with “KEY” recycled.
- 10 Flash**            **Brake on FAULT**  
Fault will occur when directional and FS1 are energized without releasing brake. Recycle FS1 through neutral to clear.
- 12 Flash**            **Current Transducer FAULT.**  
Occurs when current output is read during power-up or if no current is read during drive above 50% demand. “KEY” recycle to clear.
- 15 Flash**            **Current Transducer FAULT.**  
Occurs when current output is read during power-up or if no current is read during drive above 50% demand. “KEY” recycle to clear.



**Table 5: Traction test display**

Display name	Calibrator display	Range/Notes
"ACCELERATOR PERCENT DEMAND"	"ACCELERATOR x%"	0-100%
"ACCELERATOR VOLTAGE"	"ACCELERATOR xV"	0.0 V-5.0 V
"FORWARD SWITCH"	"FORWARD OPEN"	OPEN/CLOSED
"REVERSE SWITCH"	"REVERSE OPEN"	OPEN/CLOSED
"FS1 SWITCH"	"FS1 OPEN"	OPEN/CLOSED
"CONFIGURATION JUMPER 1"	"CONFIG 1"	OPEN/CLOSED
"CONFIGURATION JUMPER 2"	"CONFIG 2"	OPEN/CLOSED
"BRAKE INPUT"	"BRAKE ON"	OPEN/CLOSED
	"PTA LEVEL"	HIGH/LOW
"CIRCUIT BREAKER INPUT"	"CB AUX SW"	OPEN/CLOSED
	"I MAX SW"	
"SOFTWARE VERSION"	"SOFTWARE X.XXX"	VX.XXX
"DISPLAY STATUS"	"STATUS LOCK (or ROTATE)"	LOCK / ROTATE (ROTATE)
"SELECT DASHBOARD DISPLAY STATUS"	"STATUS #"	0-4 (Battery voltage, pump current, motor current, battery voltage) (0)
"DISPLAY CONTRAST"		0-127 (33)

**Table 6: Traction BDI display**

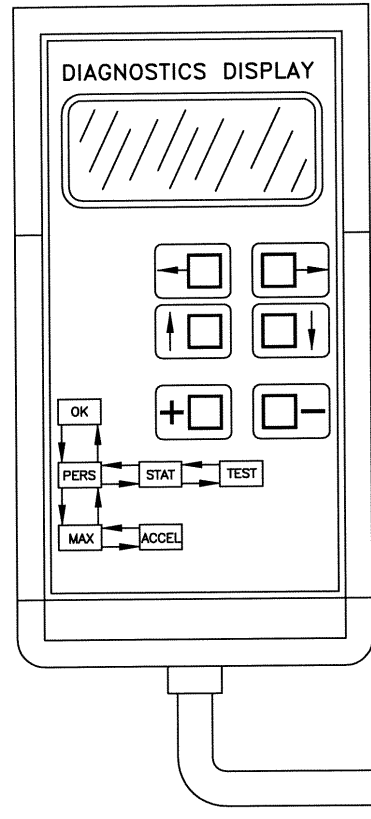
Display name	Calibrator display	Range/Notes	Adjustable with password
"RESET CELL LEVEL"	"RESET xV CELL"	1.85V-2.50V (2.04V)	X
"EMPTY CELL LEVEL"	"EMPTY xV CELL"	1.00V-1.99V (1.70V)	X
"WARNING LEVEL"	"WARNING X%"	0%-90% (20%)	X

Note 1: Values in parentheses are default values.

Note 2: When the last status (Traction test or Traction BDI) is displayed, the display will go back to the first status and scroll through again.

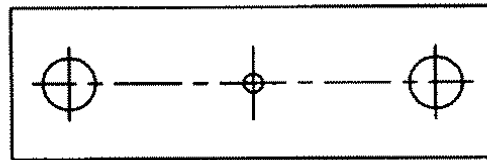


Fig. 24: Calibrator unit



© BUCYRUS AMERICA, INC.

Fig. 25: BUC2000 pump motor shunt





## Panel measurements

Before taking readings, the meter should be in DC volts (and appropriate range) and the following system conditions must be met:

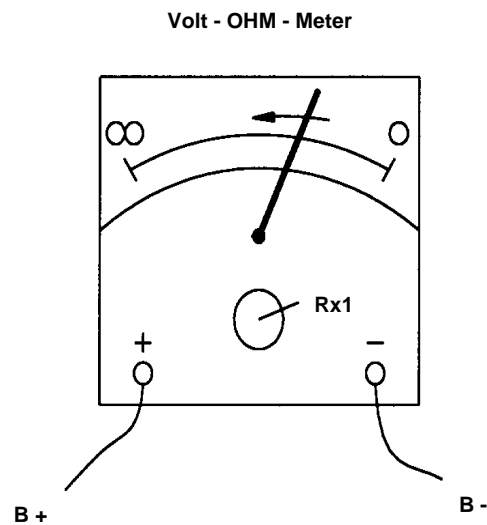
- ☞ All connections attached, and power applied.
- ☞ Main circuit breaker on.
- ☞ Master switch or control handle in the “PARK” or “PARK BRAKE APPLIED” position.
- ☞ Accelerator NOT depressed (FS1 open).

B+ to B-: Battery Voltage

B- to AA: »50V

B- to S1L, S4L, S1R, & S4R: »50V

**Fig. 32: Panel measurements**



CLICK HERE TO **DOWNLOAD** THE COMPLETE MANUAL

- Thank you very much for reading the preview of the manual.
- You can download the complete manual from: [www.heydownloads.com](http://www.heydownloads.com) by clicking the link below



- Please note: If there is no response to CLICKING the link, please download this PDF first and then click on it.

CLICK HERE TO **DOWNLOAD** THE COMPLETE MANUAL