

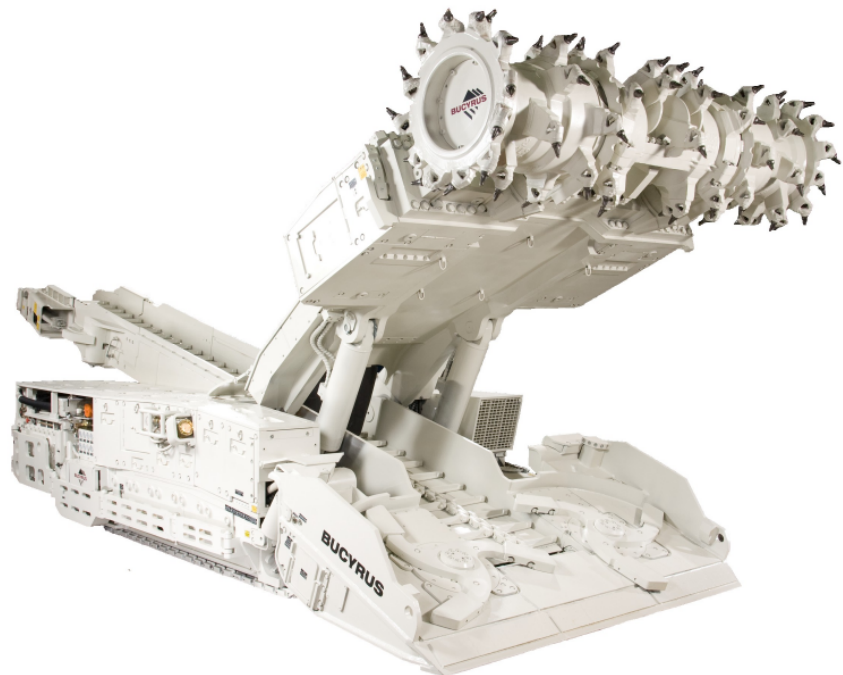

# Operation Manual

**Bucyrus - Continuous Miner  
Model - 35M3**

**Doc. No.: A6474X309**



**Bucyrus America, Inc.**

4041 Wurno Road  
Pulaski, VA 24301

Telephone: 540-980-4530  
Fax: 540-994-3763

Internet: [www.bucyrus.com](http://www.bucyrus.com)

CLICK HERE TO **DOWNLOAD** THE COMPLETE MANUAL

- Thank you very much for reading the preview of the manual.
- You can download the complete manual from: [www.heydownloads.com](http://www.heydownloads.com) by clicking the link below



- Please note: If there is no response to CLICKING the link, please download this PDF first and then click on it.

CLICK HERE TO **DOWNLOAD** THE COMPLETE MANUAL



## Characters and symbols used

The following characters and symbols are used for safety instructions and important information in the operating manual.

Try to memorize the symbols and their meanings.

### **DANGER!**

Points in the text marked with this symbol draw your attention to immediately impending danger. Possible consequences are: very serious injury or even death.

### **WARNING!**

These points contain information on dangerous situations. Possible consequences are: very serious injury or even death.

### **CAUTION!**

This symbol draws attention to dangerous situations. Possible consequences are: light to moderately serious injuries and machine damage.

### **NOTICE!**

Points in the text marked with this symbol draw attention to harmful situations. Possible consequences are: damage to the machine or damage in the immediate vicinity.



### **IMPORTANT!**

Points in the text marked with this symbol contain useful tips and information intended to facilitate work for you. They do not warn about harmful or dangerous situations.

- Items in lists are marked with bullets.
  - Points in sub-lists are marked with a long dash at the start of the line.
- ☞ Points in text marked in this way describe individual operations. Follow these instructions step by step. They will help you carry out your work faster and more importantly, safer.



## Installation and start-up

<b>inclined face</b>	On inclined faces secure all component parts by chains, e.g. to the support.
<b>environmental acceptability</b>	When working with oils, greases and other chemical substances, observe the safety regulations applicable to the product. Safety regulations can be found on the container or on the Material Safety Data Sheet (MSDS) for the product.  Dispose of cleaning rags, etc. which have been soiled with oil, grease or other chemical substances in an environmentally safe manner.
<b>controls</b>	When starting up machine, do not operate any controls located inside the operator's compartment (optional) from outside the compartment.
<b>starting procedures</b>	Follow the starting procedure instructions in the operations manual.
<b>red zone</b>	Do not operate any levers, pedals or controls if anyone is in the red zone. (See Red Zone in Chapter 5 of this manual)

## Operation

<b>training</b>	Operate the machine only if you have a profound knowledge of the control elements and their functions. It is necessary that you have been task trained on the respective Continuous Miner.
<b>before start-up</b>	Before start-up, ensure that there are no persons or obstructions in your line of travel or in the articulation area when steering the unit.
<b>protective devices</b>	Check that all protective devices are installed on the machine and function properly.
<b>traveling</b>	Use extreme caution when traveling in close quarters or in congested or blind-travel areas.
<b>passengers</b>	Never carry passengers. Passengers may be thrown off the machine or crushed between the machine and outside objects.
<b>safety rules</b>	Always follow all safety rules of each particular mine when operating the machine.
<b>problems and malfunctions</b>	If problems or malfunctions are encountered while operating the unit, the machine must be properly shutdown and the problem corrected immediately.



### NOTICE!

The Continuous Miner has skid type steering. It is capable of turning within its own limits.

### WARNING!

Tramming requires cooling water to the tram motors. Failure to cool the motors will result in motor damage and premature failure.

### DANGER!

If the miner is under unsupported roof and tramming with the emergency pendant controls is required, crib out to the miner. Never go out under unsupported roof. Failure to follow this warning may result in very serious injury or death.



### IMPORTANT!

The miner can be shutdown at any time in “ETRAM” mode by pressing the “MACHINE STOP” button on the emergency tram pendant.

### WARNING!

As soon as a tramming function is performed, the stabilizer shoe will raise automatically. If the shoe is being used to lift the miner off of the floor, the rear of the machine will drop as soon as the tram function is performed. Serious injury or death can occur to personnel.

### CAUTION!

Always ensure operator safety while operating the machine. Be alert for hazardous conditions and take corrective action as necessary. Failure to be alert and correct hazardous situations may result in serious injury.



### IMPORTANT!

Care should be taken not to stall cutters or conveyor during cutting operations. Severe damage to motors and gear boxes could occur if cutters or conveyor are repeatedly stalled.



### IMPORTANT!

Tram is limited in the forward direction while the cutters are running with the cutter head feedback circuit. As the cutter head begins to cut the material from the face, the sump speed will automatically slow the tram down to prevent over sumping the machine.

### WARNING!

This section is intended to familiarize the user with the major mechanical assemblies of the Continuous Miner. All mechanical maintenance should be performed by a qualified technician with the knowledge of the function of the assemblies involved.

### WARNING!

Failure to maintain the hydraulic system will result in damage to its hydraulic components which will result in increased wear and premature failure.

---

# 3

## Storage and transport

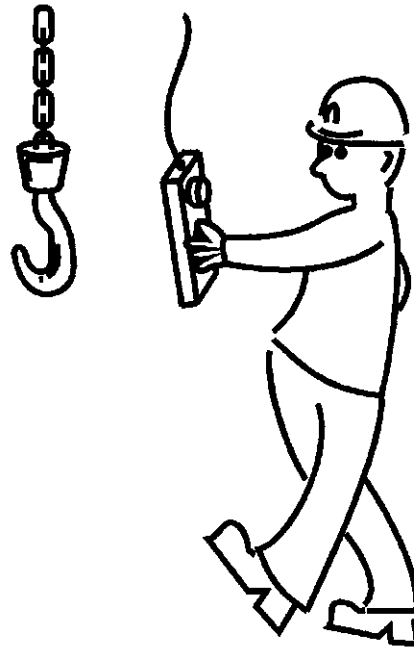



# Installation

## Points to observe prior to installation

### Who is allowed to carry out installation?

Installation is only allowed to be carried out by personnel having received adequate training to perform this task.

Work on:

- the safety components (pressure relief valves, fire extinguishing equipment etc.)
- the electrical equipment (control units, signaling devices, etc.)
- the hydraulic equipment (cylinders, directional control valves, hoses etc.)

should only be carried out by Bucyrus America, Inc. service engineers or by specially trained personnel.

### Which tools are required for installation?

#### tool box

No special tools are required to put the Continuous Miner into service.

Various items of auxiliary equipment and machines may be required at the point of installation.

These include:

- hoists with adequate lifting capacity
- means of attachment with adequate lifting capacity
- unloading dock and crib blocks
- jacks with adequate lifting capacity
- impact wrenches, including accessories

---

# 5 Operation





**main circuit breaker**

The main circuit breaker case (Fig. 14) is located at the right hand rear of the machine above the main case. Incoming cable is connected to the machine via the cable handler and the victor cable socket.

The case contains a circuit breaker providing 600A overload and 1500A short circuit protection to the machine. The circuit breaker also functions as an isolation device for the machine.

**DANGER!**

**Power to the machine must always be isolated to the trailing cable at the section power center before either the victor socket is removed or the main circuit breaker case is opened. Whenever any work is performed on the continuous miner, all mine, State, and Federal regulations regarding lockout/tagout of the machine.**

**Fig. 14: Main circuit breaker**

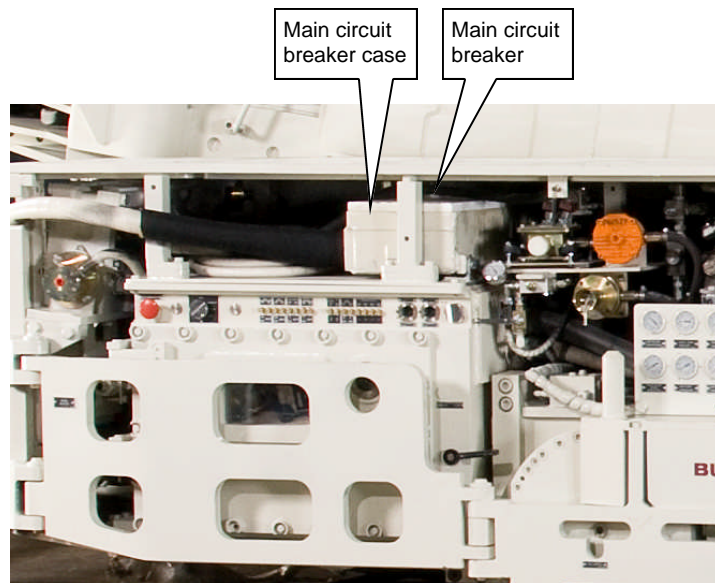



**graphics display**

The graphics display (Fig. 19) is located above the methane monitor on the right rear bumper of the machine. The graphics display is used to monitor machine operating parameters, for diagnosing error and fault codes, and for input of operating parameters

A system halt message can appear as a pop-up dialog box in the middle of any screen. This message appears when a critical condition has occurred that prevents continued operation of the machine in a safe manner. The message box cannot be cleared and it is necessary to recycle power to the control system to restore machine operation.

**Fig. 19: Graphics display**

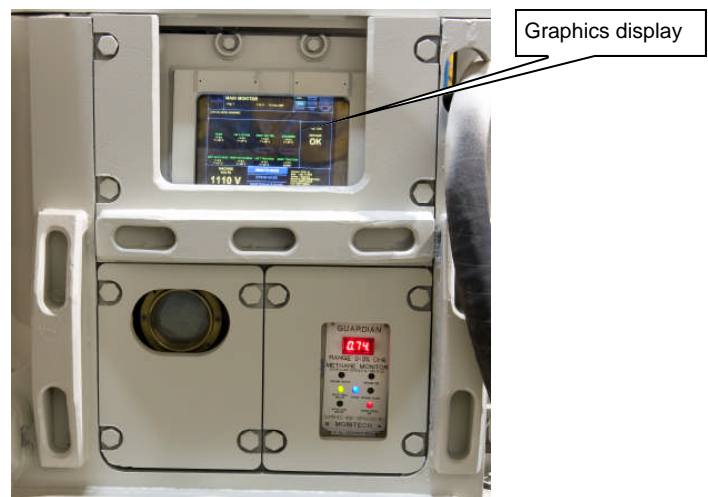



8. Pre-Start Timers
  - a. Pump
  - b. Scrubber
  - c. Cutters
  - d. Conveyors
  - e. Mode change
9. Motor Config
  - a. Motor full load current settings (viewing only)
    1. Pump
    2. Scrubber
    3. Cutter
    4. Conveyor
    5. Traction
  - b. Shear max cutter current
  - c. Shear min cutter current
  - d. Motor trip timers
    1. Cutter imbalance run-time
    2. Cutter imbalance startup
    3. Traction undercurrent time
    4. Traction illegal current time
10. Traction Config
  - a. Left hand trim
  - b. Right hand trim
  - c. Sump settings
    1. Max cutter current
    2. Min cutter current
    3. Sump speed delta
    4. Left hand max sump speed
    5. Right hand max sump speed
    6. Left hand min sump speed
    7. Right hand min sump speed
  - d. Left tram speeds
    1. Speed 1
    2. Speed 2
    3. Speed 3
  - e. Right tram speeds
    1. Speed 1
    2. Speed 2
    3. Speed 3
  - f. Tram start delay
11. Auto Stab Config
  - a. Auto stab enable
  - b. Auto stab in coal seam current
  - c. Auto stab down timer
12. Password Setup
  - a. Tradesman Password
13. Date/Time Config
14. Clear Fault Log Page
15. Reset Defaults Page



## Safety precautions for underground operation

In addition to the preceding instructions for operating the Continuous Miner, observe the following special precautions after the Continuous Miner is taken underground.

- Communication is a key element in maintaining safety. Exact instructions and warnings should be given to, and thoroughly understood by each workman. Good communications between the entire crew must be maintained throughout the shift.
- Check the condition of the trailing cable before turning power on at the power source.
- This machine must be maintained in a permissible condition, following all state and federal laws.
- Make a visual check of the Continuous Miner before energizing. Look for loose bolts, covers, locking devices, damaged parts, and cracked or broken lenses. Any part of the machine which does not function properly is a hazard. Report it immediately to your immediate supervisor or their designee.
- Prior to operation, make sure the working area is safe. Make a visual inspection of roof and ribs and take all steps necessary to insure safety.

## Tramming safety rules

- Communicate your intentions to the workmen affected by the movement of the Continuous Miner.
- Check the position of the water hose and trailing cable to be sure there is sufficient slack to finish the operation.
- Note the condition of the roadways and physical surroundings of the route.
- Position the cutter and gathering head for tramming.
- Position the stabilizer shoe and booms for tramming.
- Position your body completely inside the operator's compartment (optional), facing the intended direction of travel.
- Position the Continuous Miner in the center of the road way to allow maximum safe clearance. Consistently maintain clearance, which is critical to the safe movement of the Continuous Miner.



## Scrubber motor

### To start the scrubber fan motor

- ☞ Ensure that the pump motor is running as the scrubber motor will not start if the pump motor is not running.
- ☞ Press “SHIFT” and wait 1/4 second.



#### **IMPORTANT!**

**Holding the “SHIFT” button for two (2) seconds or longer will result in a radio switch fault. If this occurs, all buttons must be released and the start re-attempted.**

- ☞ While holding shift, press “FAN/OFF”. The pre-start warning horn will sound. Continue to hold until the scrubber fan motor turns on.
- ☞ Release the “FAN/OFF” button. The pre-start warning horn will stop.



#### **IMPORTANT!**

**The “FAN/OFF” button must be released before “SHIFT”. If “SHIFT” is released first, the fan motor will shut off.**

- ☞ Release the “SHIFT” button.

### To stop the scrubber fan motor

- ☞ Press and hold the “FAN/OFF” button. The fan motor will shut-down immediately.
- ☞ Release the “FAN/OFF” button.



**The next face cut**

Having cut bottom clearance for the gathering head blade, the operator can now make a deep sump at the top such as a full drum diameter as shown in the first view of Fig. 37. He can commence his down-cut until his gathering head pan is full. Optimally, all this is being done while awaiting the next haulage car so that maximum loading rate can be achieved when the car arrives.

While loading the haulage car, the operator completes the down-cut to the mine bottom as shown in the second view of Fig. 37.

Depending on the depth of the top sump, a small cusp of coal will be left behind the drum on the mine bottom. This cusp is removed by backing the miner out of the face a small distance while the cutter head is running.

The miner is now in a similar position as that shown in the first view of Fig. 36 and the operator can proceed with the next cutting cycle.

**Using the stabilizer shoe**

The stabilizer shoe is located under the rear deck of the main frame and beneath the conveyor. It is hinged at its front edge and is lowered by a hydraulic cylinder.

The stabilizer shoe serves two purposes:

- To elevate the rear of the miner for maintenance work.
- To provide stability, if necessary, during sumping.
- To provide a higher down-cut force at the coal face while shearing down during mining operations.

The advantage of increasing down-cut force at the face while shearing down is important particularly when cutting hard coal seams. Fig. 37 illustrates the advantage of the stabilizer shoe in the down-cut application.

**Fig. 37: The next face cut**

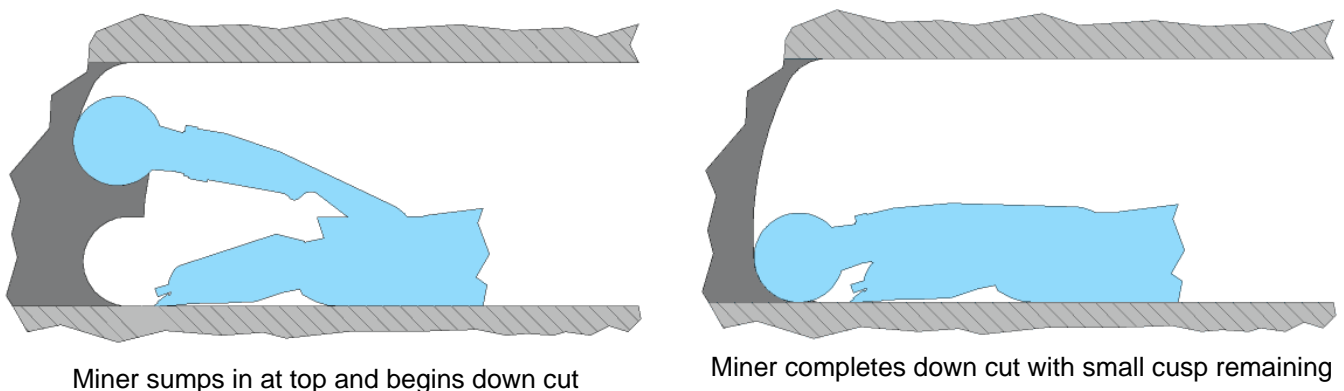



## Hydraulic system overview

Hydraulic power for all hydraulically-actuated functions originates with the pump assembly. This includes power for cylinders, hydraulic motors, control valves, and pilot valves.

Fig. 46 gives an overview of hydraulic cylinders located on the 35M3 Continuous Miner. Fig. 47 shows the location of other hydraulic components.

This section gives general descriptions of the hydraulic components used on the miner along with typical schematics for hydraulic functions. The schematics in this section are general; always refer to the hydraulic schematic in your Bucyrus America, Inc. parts manual supplied with your machine.

## Operation considerations

In order for a hydraulic system to function correctly, it must be properly maintained. Maintenance of the hydraulic system includes:

- maintaining atmospheric pressure in the tank by keeping the breather clean and free of obstructions;
- maintaining a sufficient oil level in the tank;
- maintaining tight, leak-proof pump suction lines to prohibit air being pumped through the system; and
- changing filters and fluids at prescribed intervals.

### **WARNING!**

**Failure to maintain the hydraulic system will result in damage to its hydraulic components which will result in increased wear and premature failure.**

For complete maintenance procedures, see the Maintenance section in this chapter.



## Valves

The hydraulic symbols for the different types of valves are given in Fig. 53.

<b>ball valve</b>	A valve that checks flow by the seating of a ball. Ball valves are typically operated by hand.
<b>check valve</b>	A valve that allows fluid flow in one direction only.
<b>directional control valve</b>	A directional control valve is typically solenoid operated and is used to extend/retract a cylinder.
<b>flow control valve</b>	A valve with a primary function of controlling flow rate.
<b>flow control valve with internal check</b>	A valve with a primary function of controlling flow rate in one direction and allow free flow in opposite direction.
<b>load holding valve (load lock valve) (overcenter valve)</b>	The purpose of the load holding valve is to prevent the accidental lowering of a hydraulic cylinder, whether by sudden or gradual circuit depressurization, either during operation or maintenance. The load holding valve (also called a "load locking valve") may be a pilot-operated check valve, a counterbalance valve, or an overcenter valve.

A load holding valve locks a load in any position without allowing drift. It may provide static overload relief and thermal expansion relief with open-center control valves, as are on the cutter head raise circuit, or be combined with an atmospheric relief, as on the conveyor raise circuit of the miner. Cartridge style valves allow installation directly into the cylinder.

In the event of hydraulic system failure or a deliberate system shutdown (as during maintenance), the absence of pilot pressure to the spring-loaded valve automatically closes off the return line and prevents fluid from leaving the cylinder (and thereby stops the piston from moving). The load holding valve is used on the miner, in conjunction with mechanical blocking, when the cutter head or conveyor must be elevated for extended periods of time so that repairs can be effected beneath.

### WARNING!

**Do not rely on the load holding valve when working under the cutter head or the conveyor. Always block the conveyor or the cutter head if it must be elevated. Serious injury or death may result from not mechanically blocking the load.**

An overcenter valve is merely a counterbalance valve with a pilot override on the relief valve section. The load raises by free oil flow through the bypass check section. With the control valve centered in NEUTRAL, the load is locked (the relief must be set at least 1.3 times higher than the maximum load induced pressure or system pressure).



Fig. 59: Cutter head raise circuit

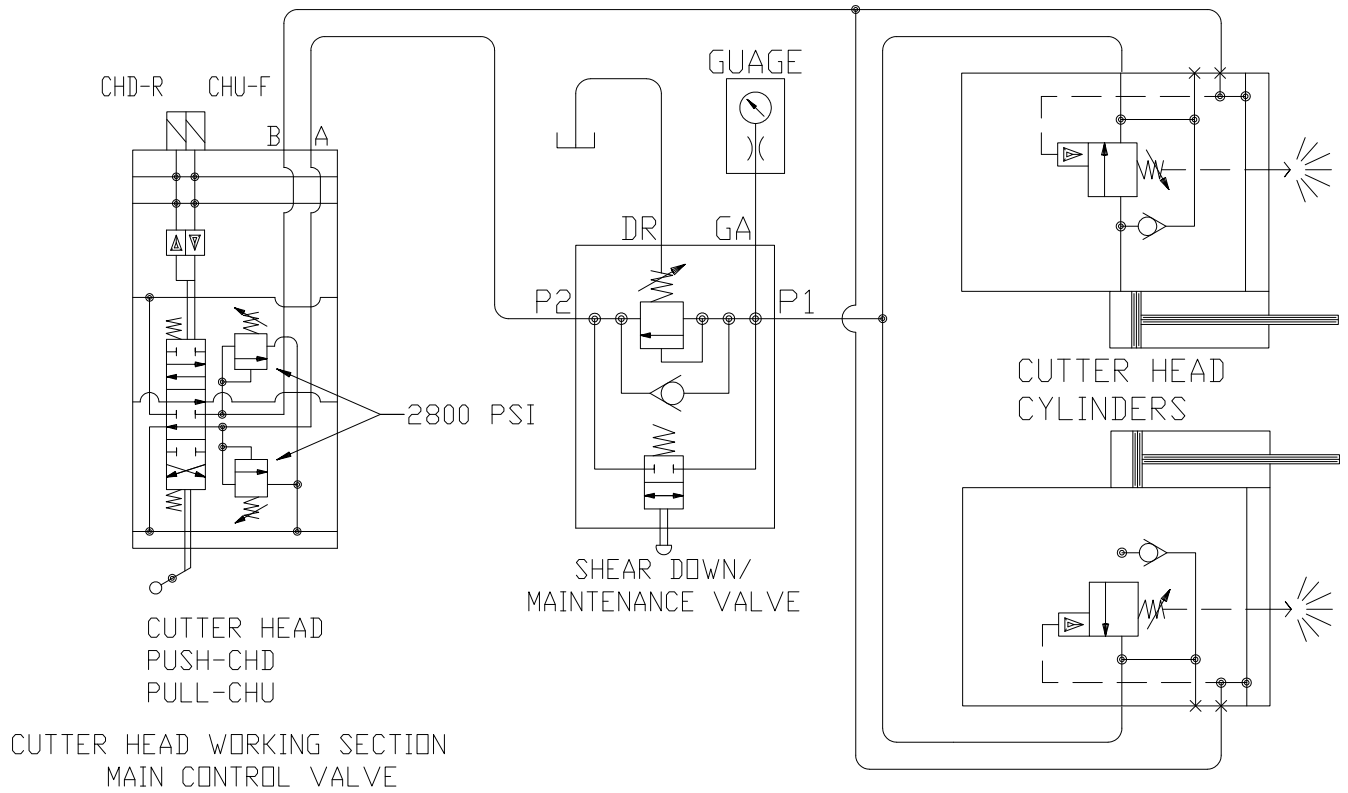

© BUCYRUS AMERICA, INC.



## Reduced MCV pilot pressure circuit - radio function main control valve

The pilot pressure circuit is powered by hydraulic pump gear section A3 which is rated at 31 Lpm at 35 bar (8.1 at 500 psi). From the pump, the pilot pressure oil passes through a 3 micron non-bypassing filter. The pilot pressure is controlled by a pressure relief valve that is normally set to 35 bar (500 psi). When the non by-passing 3 micron filter element starts clogging with trapped particles, the radio system/solenoid functions will slow down, indicating that it is time to change the filter element. For filter element maintenance and changing schedules, see the Maintenance section of this chapter.

Oil continues to the pilot port of the main control valve. The reduced pressure is required to prevent damage to the main control valve. This supplies oil pressure, which allows the small solenoid pilot valve to shift the spools in the working sections of the main control valve.

The five (5) working sections are as follows: cutter raise, conveyor raise, conveyor swing, gathering head, and stabilizer. The pilot circuit allows the miner operator to operate the main control valve by the radio system.

When the solenoid coil is energized it shifts the spool in the main control valve, allowing oil flow to the selected function. When the solenoid coil is de-energized, the spool in the main control valve goes to the neutral position.

The schematic shown in Fig. 65 is a typical reduced pilot pressure circuit. Always refer to the schematic in your Bucyrus America, Inc. Parts Book for your machine.



## Scrubber back flush circuit

The scrubber back flush circuit utilizes water supplied from the water distribution manifold and is operated by remote solenoid control (see Electrical section in this chapter). When the scrubber back flush solenoid coil (B/F) is energized, it shifts a spool, allowing hydraulic oil to flow to the hydraulic pilot operated, normally closed water valve. The hydraulic oil shifts the spool, allowing water to pass through it to the scrubber back flush nozzle. For the hydraulic portion of this circuit, see the Hydraulic section of this chapter.

The scrubber back flush circuit described above is for a typical Bucyrus 35M series miner. The circuit for your machine may vary depending on your dust plan and unique requirements. Always refer to the schematic in the Bucyrus parts book for your machine.

**Fig. 70: Scrubber back flush circuit**

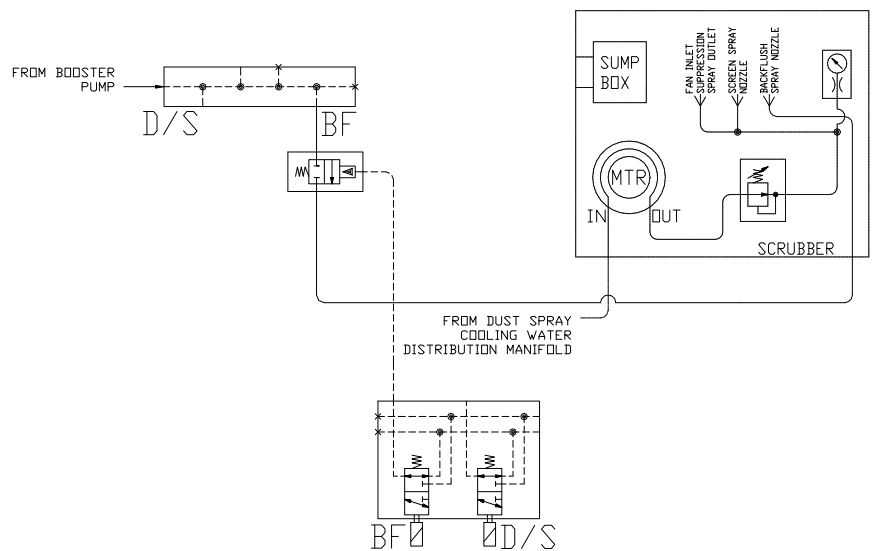
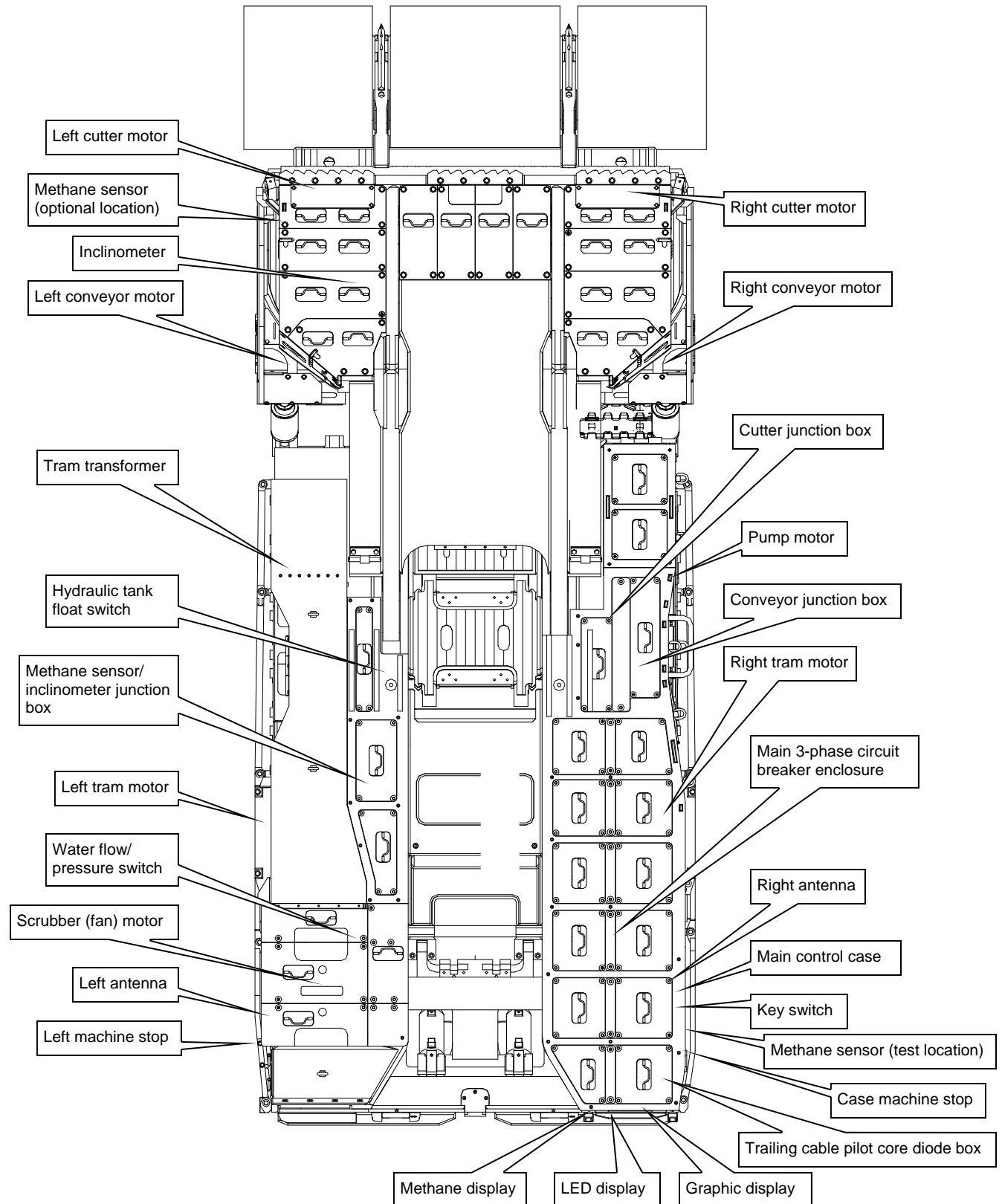



Fig. 78: Electrical component locator



© BUCYRUS AMERICA, INC.



**Controller case swing panel - rear side**

The rear side of the swing panel (Fig. 85) is accessed by opening the controller cover and then opening the swing panel. Typically mounted on the rear of the swing panel are the control system components.

**IMPORTANT!**

**This component location information is typical. Always verify component layout with the information in the Bucyrus parts book for your machine.**



**power supply**

The power supply module converts a 110VAC input to 24VDC output for the control system.

**central processor**

The control system software is stored on the central processor (control module).

**relay module**

The relay module, also called an I/O module, receives both digital and analog inputs and communicates them to the central processor.

**solenoid module**

The solenoid module communicates commands from the central processor to the machine solenoids.

**thermistor module**

The thermistor module communicates the RTD/thermistor inputs (various temperature readings on the machine) to the central processor.

**power supply "MMPS"**

"MMPS" is the power supply for the methane and water monitoring system.

© BUCYRUS AMERICA, INC.

**Fig. 85: Controller case swing panel - rear side**

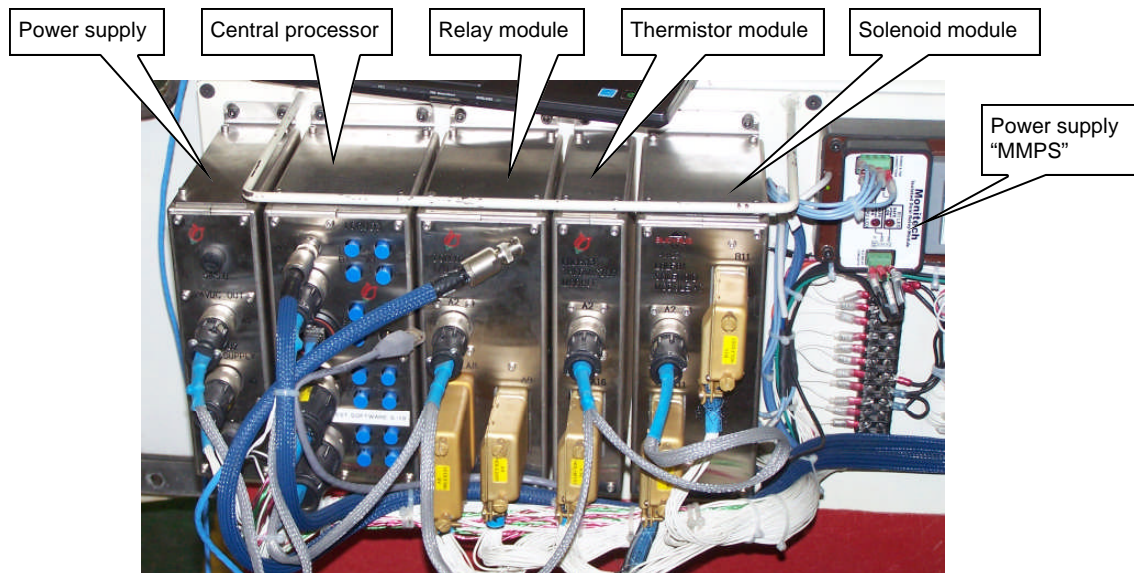



### Motor control

The control system monitors the motor load by reading the current in each phase to the motor. The motor mate (control transformer) takes the current for each phase of the motor and converts it to a 4mA to 20mA signal to the processor.

The schematic shown in Fig. 94 is a typical. Always refer to the schematic in the Bucyrus parts book for your machine.

Fig. 94: Motor control

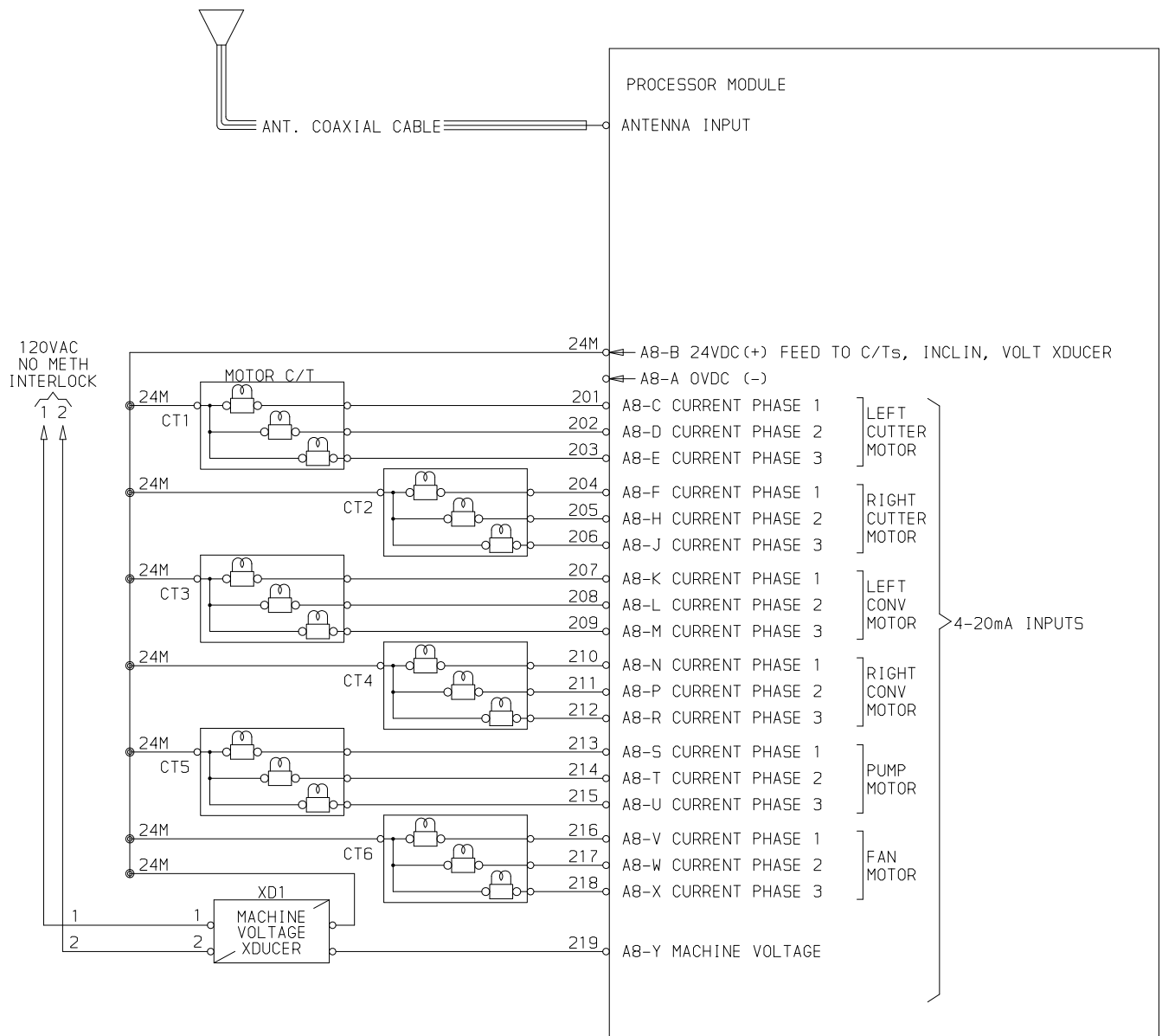

© BUCYRUS AMERICA, INC.



Fig. 97: Lubrication and maintenance chart, continued

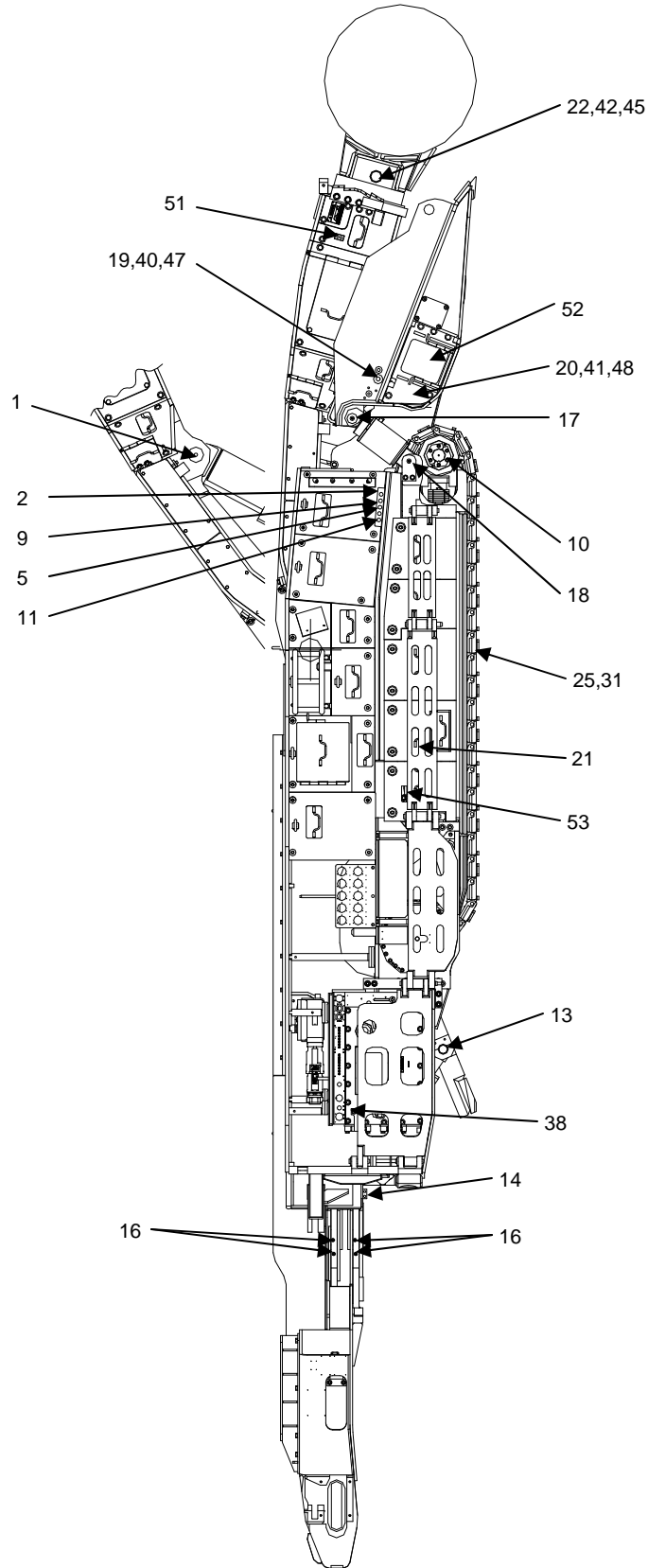

CLICK HERE TO **DOWNLOAD** THE COMPLETE MANUAL

- Thank you very much for reading the preview of the manual.
- You can download the complete manual from: [www.heydownloads.com](http://www.heydownloads.com) by clicking the link below



- Please note: If there is no response to CLICKING the link, please download this PDF first and then click on it.

CLICK HERE TO **DOWNLOAD** THE COMPLETE MANUAL



**CLA head pot assembly  
(right and left)**

Level the miner and place the gathering head on grade before checking or adding lubricant. Check the oil level in the pot assembly (Fig. 110). If oil is needed, add oil through the fill hole until oil comes out the breather.

**CLA head transfer case  
(right and left)**

Level the miner and place the gathering head on grade before checking or adding lubricant. Check the oil level in the hydraulic transfer case (Fig. 110). If oil is needed, add oil through the fill hole until oil comes out the breather.

**Fig. 110: CLA head pot assembly and transfer case lubrication**

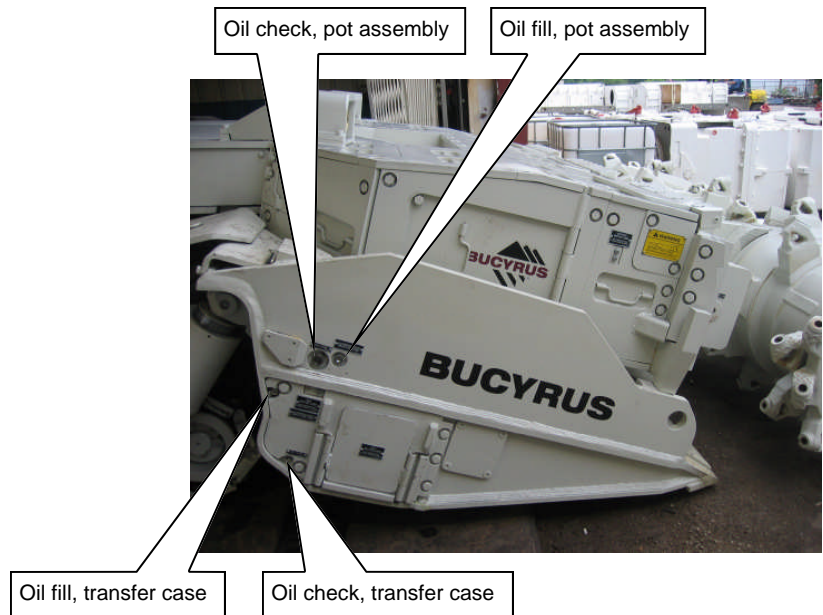

**tram gear case  
(right and left)**

With the miner in a level position, check the oil level in both tram gear cases by looking at the sight glass located on the side of each gear case (Fig. 111). Oil should be visible in each sight glass. If oil level is low, add oil through either the fill pipe (accessed from the top of the machine) or the fill plug hole (accessed from the side of the machine).

**Fig. 111: Tram gear case oil level (typical both sides)**

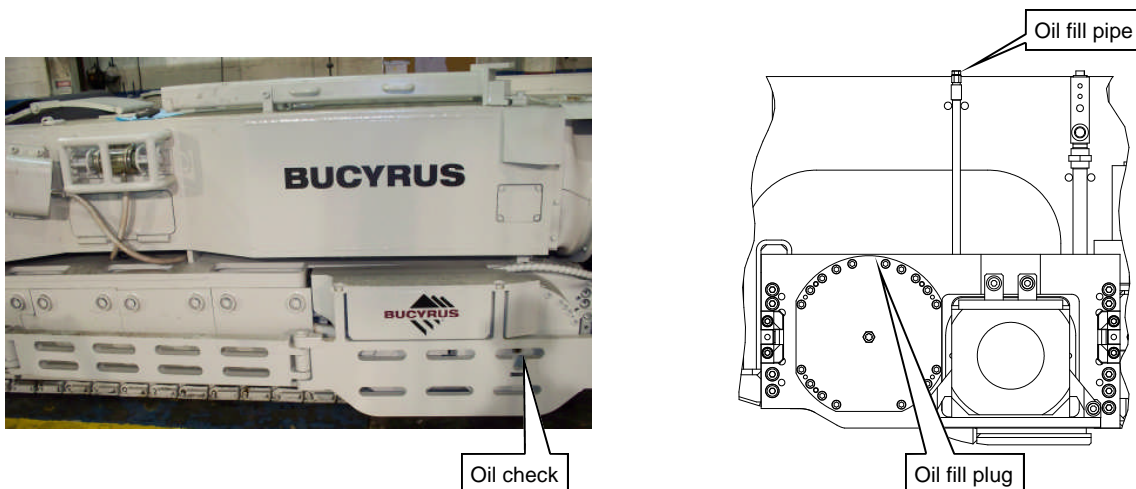

**main cutter head gear case**

Change the oil in both main cutter head gear cases (Fig. 122).

- ☞ Lower the cutter head completely to the ground. Clean dirt and debris from around the drain plug, located under the gear case.
- ☞ Remove the drain plug and allow oil to completely drain from the gear case.
- ☞ Clean and reinstall the drain plug.
- ☞ Clean dirt and debris from around the check plug and remove the plug.
- ☞ Clean dirt and debris from around the fill plug and remove the plug.
- ☞ Slowly add oil through the fill plug until oil begins to flow from the check plug hole. Allow sufficient time for the oil to travel throughout the gear case when filling.
- ☞ Clean and reinstall the check and fill plugs.

**Fig. 122: Main cutter head gear case**

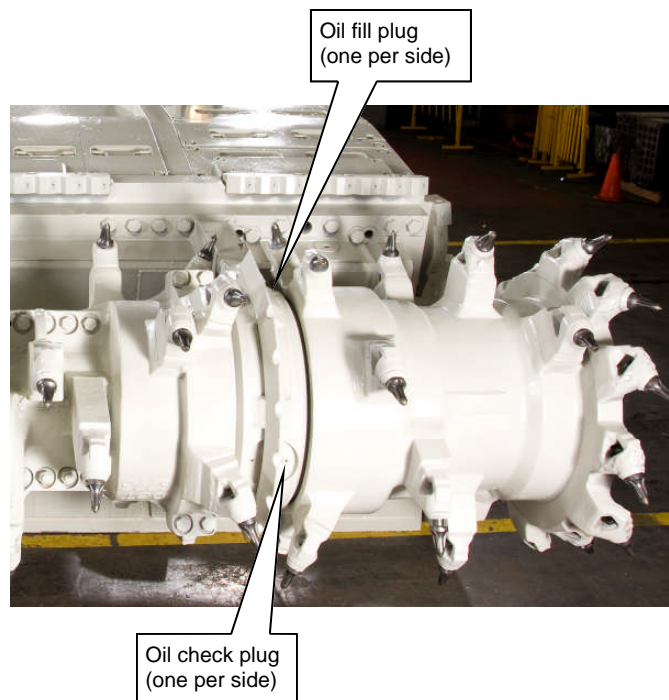



### hydraulic oil, suction strainer, and breather

Change the oil in the hydraulic oil tank (Fig. 130).

- ☞ Clean all dirt and debris from around the fill cap and the drain plug.
- ☞ Remove the drain plug and allow the oil tank to completely drain.
- ☞ Remove and replace the suction strainer.
- ☞ Clean and reinstall the drain plug.
- ☞ Replace both breathers.
- ☞ Add oil to the tank until the oil level is correct on the dipstick.
- ☞ After filling, start the machine and engage all hydraulic cylinders for their full length of travel (full extend and retract) in order to purge the hydraulic system of air.
- ☞ Recheck the oil level on the dipstick. Add more oil as needed.

**Fig. 130: Hydraulic oil tank**

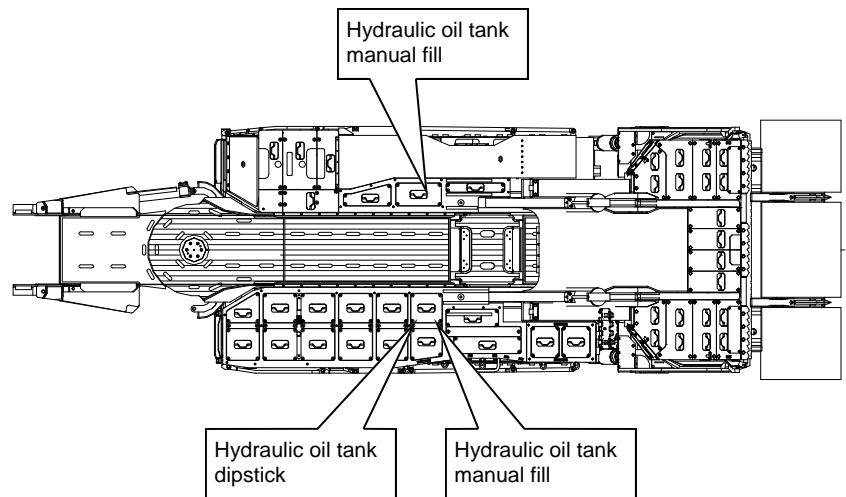



- ✎ 10. Remove the hex head capscrews and lock washers that secure the front rub rail to the tractor frame (Fig. 133) and open the front rub rail cover.

**Fig. 133: Rub rail removal**

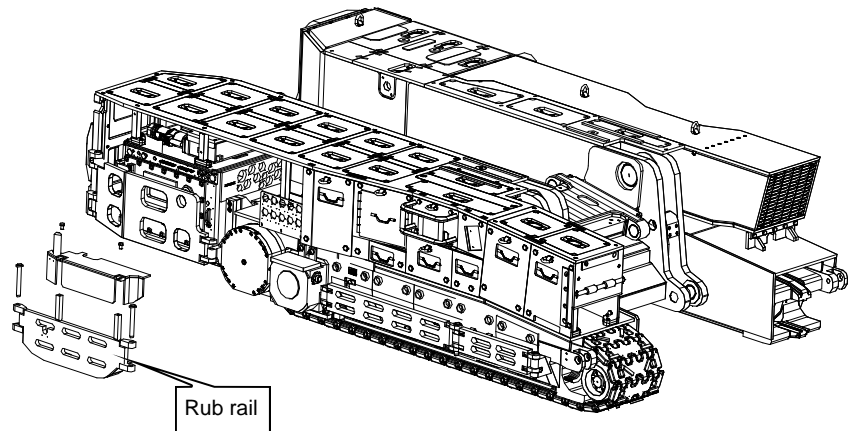

- ✎ 11. Remove the cover plate to allow access to the idler assembly.
- ✎ 12. Locate the front idler take-up jack grease fitting and attach the grease gun to the fitting.
- ✎ 13. If the tram track tension is too tight, readjust the idler position using the following steps:
  - Pump grease into the take-up jack to extend the cylinder and remove pusher plate pressure on the idler shims.
  - Remove one or more idler adjustment shims from the idler slide channel.
  - Open the pressure release valve for the front idler take-up jack and allow the jack to contract. The pusher plate will slide backwards until it is stopped by the remaining idler shims.
  - Pump grease into the idler take-up jack to extend the cylinder, move the idler assembly forward and tighten the tram track until it is at the correct tension. The tram track is at the proper tension when it hangs 64 to 89 mm (2-1/2 to 3-1/2 inches) from the bottom wear shoes when the tractor frame is blocked off the floor.



## Instructions on the replacement of wear parts

It is essential that wear parts be replaced before reaching the lowest wear limit. To ensure that this happens, wear parts must be inspected at regular intervals.

**CAUTION!**  
**Disassembly and assembly procedures listed in this section are specialized and, as such, should only be performed by qualified personnel.**

### Cutter head (boom) assembly

The cutter head assembly (Fig. 140) is powered by two AC electric motors mounted on each side of the cutting head support frame. Each motor drives through a torque limiting clutch to an input gear case, which in turn drives a common shaft, allowing the two drive motors to share the cutting load. Each input gear case is removable as a separate unit from the main cutting head gear case. The cutting head is attached to the main frame at a heavy-duty pivot. Two hydraulic cylinders raise and lower the cutting head.

The cutter head assembly can be removed as an assembly or as individual components.

Fig. 140: Cutter head assembly

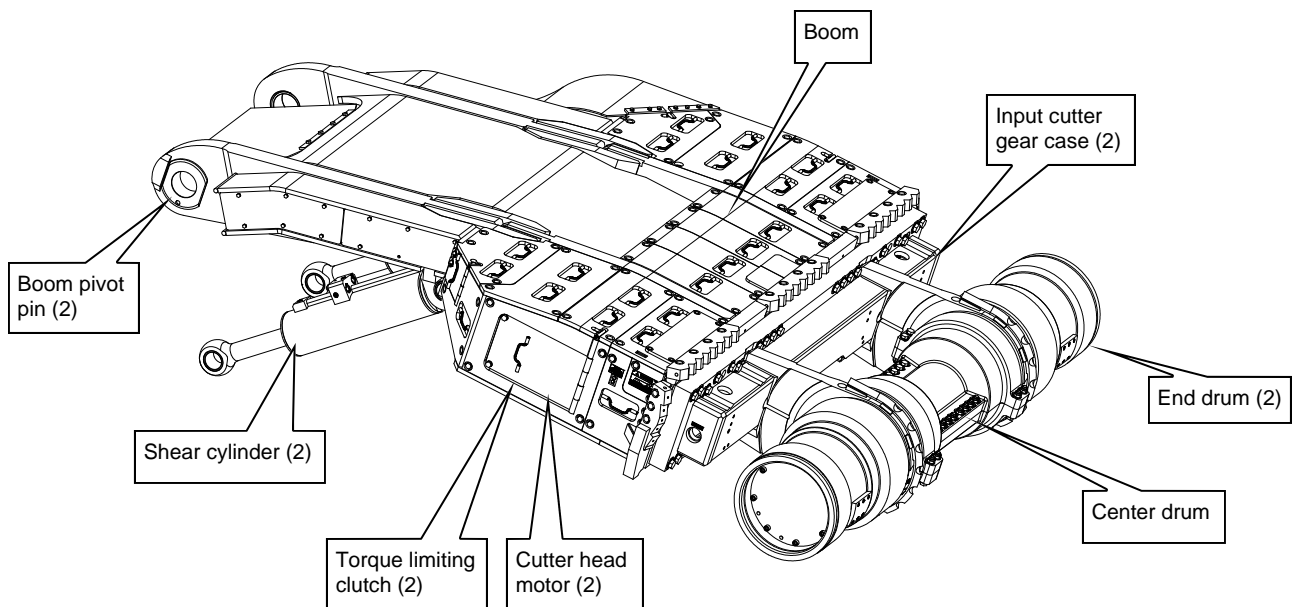



### center cutter drum removal

#### Center cutter drum removal and installation

To remove the center cutter drum (Fig. 144):

- ☞ Lower the gathering head until it touches the floor. Lower the conveyor assembly until it is level with the floor.
- ☞ Slowly rotate the cutter head until one of the center drum seams appears directly in front and one appears directly in the rear of the cutter head.
- ☞ Lower the cutter head assembly until it is resting on the floor.
- ☞ Disconnect and lockout the trailing cable. Follow all Mine, State, and Federal lockout/tagout procedures.

#### **WARNING!**

**Failure to follow all Mine, State, and Federal lockout/tagout procedures may result in machine damage or serious injury or death of personnel.**

- ☞ Remove the twenty-four (24) socket head bolts from that secure the two halves of the center drum to each other. Make sure to collect the bolts, the forty-eight (48) flat washers, and the twenty-four nuts for use in reassembly.
- ☞ Attach a lifting device to the top half of the center drum and lift the it off of the assembly. It may be necessary to use a pry bar or other force to break the seal between the top and bottom halves of the center drum before the top half can be lifted off.

#### **WARNING!**

**You could be seriously injured or killed by falling loads. Observe the safe working load limits of all lifting and blocking devices and stay clear of suspended loads.**

- ☞ Remove the four (4) alignment keys from the bottom half of the center drum and store for use in reassembly.
- ☞ Connect the trailing cable to energize the machine.
- ☞ Slowly raise the cutter head assembly until it is clear of the bottom half of the center drum.
- ☞ Slowly tram the miner backwards away from the bottom half of the center drum.



### cutter drum drive motor installation

To install the cutter drum drive motor (Fig. 149):

#### **WARNING!**

**Federal law requires that mining equipment electrical components must be inspected by a certified electrician before the equipment can be operated.**

#### **WARNING!**

**This procedure involves attaching an electrical power cable to a motor. The trailing cable must be disconnected and locked and tagged out to safely perform this operation. Follow all Mine, State, and Federal lockout/tagout procedures. Failure to do so may result in serious injury or death.**

- ☞ Block up the cutter head drum drive motor in position against the rear of the boom so that the motor's mounting holes align with the boom's motor mounting holes.

#### **WARNING!**

**Observe the safe working load limits of all lifting and blocking devices. You can be seriously injured or killed by falling loads.**

- ☞ Insert the mounting bolts to secure the motor to the boom. Torque appropriately.
- ☞ Install the two motor cooling water fittings into the cooling water ports on the motor.
- ☞ Attach the cooling water hoses to the fittings.
- ☞ Remove the four (4) hex head capscrews that secure the junction box cover and then remove the junction box cover.
- ☞ Insert the three lugs of the power cable (with gland and stuffing box already installed) into the motor's junction box.
- ☞ Tighten the two socket head capscrews to secure the gland to the junction box.
- ☞ Inside the junction box, locate the motor's lug connections.
- ☞ Match the motor lugs with the corresponding power cable lugs.
- ☞ Attach the first motor lug to its corresponding power cable lug by inserting a hex head capscrew through the motor lug, the power cable lug, a flat washer, and a lock washer. Secure the capscrew with a hex nut. Repeat for the other two lugs.
- ☞ When all three connections have been secured, wrap each of the three connections with a layer of rubber tape, then a layer of black tape, and then a layer of glass tape.
- ☞ Verify correct phasing.



- ☞ Align the gathering head frame clevises with the gathering head cylinder rod end clevises. Install the upper cylinder pins through the clevises and secure.
- ☞ Lubricate the cylinder and pivot pins.
- ☞ Install the conveyor chain (see Conveyor chain installation procedure in this chapter).
- ☞ Connect all water lines to the motors.
- ☞ Connect the electrical leads to the motor.
- ☞ Secure the motor access cover to the gathering head frame with the capscrews.
- ☞ Check the oil levels in the gathering head pot cases and the gathering head input gear cases.



Fig. 157: Foot shaft assembly removal and installation

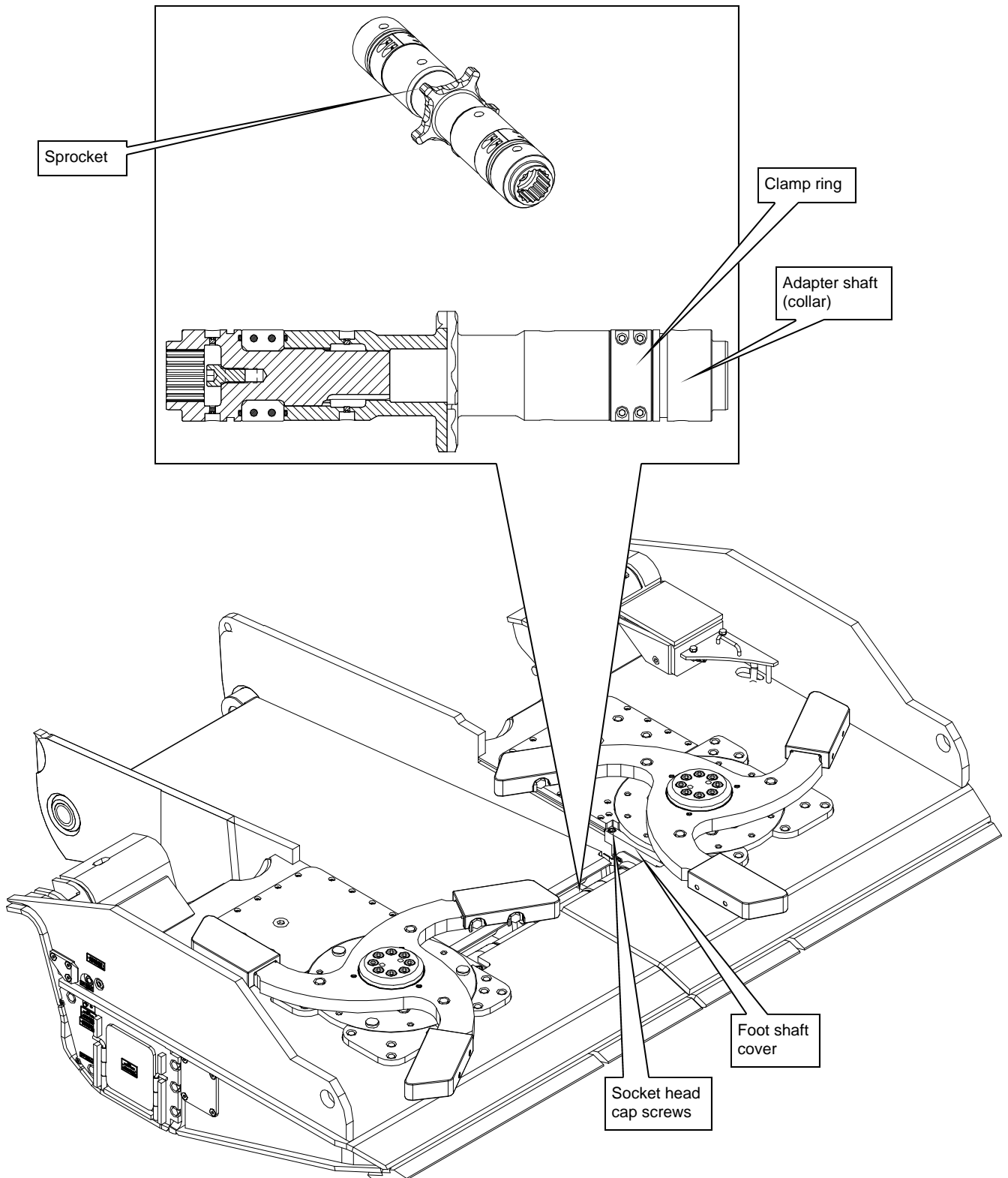

© BUCYRUS AMERICA, INC.



### Tram motor removal and installation

#### tram motor removal

To remove a tram motor (Fig. 171):

- ☞ Position the miner so that there is adequate work space on the side from which the motor is being removed.
- ☞ Block the miner so that the tram track is clear of the floor and is free to turn. Be sure that the miner is level when blocked.

#### **WARNING!**

**Observe the safe working load limits of all blocking devices. You can be seriously injured or killed by falling loads.**

- ☞ Disconnect and lock out the electrical power to the miner. Follow all applicable mine, State, and Federal regulations regarding lock-out/tagout procedures.

#### **WARNING!**

**Failure to follow all Mine, State, and Federal lockout/tagout procedures may result in machine damage or serious injury or death of personnel.**

- ☞ Remove the two (2) bolts that secure the top cover to the tram rub rail and slide the top cover off of the tram rub rail.
- ☞ Remove the two (2) rub rail pins that secure the tram rub rail to the two rub rail sections adjacent to it and then remove the tram rub rail to expose the tram gear case.
- ☞ Remove the capscrews that secure the end cap on the motor.
- ☞ Remove the snap ring inside the motor shaft.
- ☞ Remove the shaft plug and o-ring, exposing the quill shaft.
- ☞ Carefully remove the quill shaft and store in a safe place.
- ☞ Remove the two (2) socket head capscrews, two hardened steel washers, and the clamp bar that secure the motor to the tram case.
- ☞ Remove the two (2) socket head capscrews and two (2) hardened steel washers that secure the motor to the tram case.
- ☞ Replace the end cap on the motor and secure with the four capscrews.
- ☞ Disconnect, tag, and cap the cooling water hoses from the cooling water fittings located on the right and left top corners of the motor.



### Crawler chain removal and installation (with grease take-up)

#### crawler chain removal

To remove the crawler chain (Fig. 164):

- ☞ Position the miner so that there is sufficient clearance to work and enough space to pull the chain off.
- ☞ Block the machine so that the crawler assembly is off of the mine floor. Do not place blocking under the crawler track.
- ☞ Raise the gathering head assembly to its highest position and securely block it.

#### **WARNING!**

**Observe the safe working load limits of all blocking devices. You can be seriously injured or killed by falling loads.**

- ☞ Lower the cutter head assembly so that it rests on the gathering head.
- ☞ Lower the conveyor.
- ☞ Disconnect and lock out the electrical power to the miner. Follow all applicable mine, State, and Federal regulations regarding lockout/tagout procedures.

#### **WARNING!**

**Failure to follow all Mine, State, and Federal lockout/tagout procedures may result in machine damage or serious injury or death of personnel.**

- ☞ Attach a grease gun to the crawler grease take-up fitting and pump grease into the take-up cylinder to extend the cylinder and remove pusher plate pressure on the idler shims (Fig. 163).
- ☞ Remove the hex head cap screw securing the shims to the take-up housing and remove all shims and store them in a safe place (Fig. 163).
- ☞ Bleed off pressure in the grease take-up cylinder by opening the needle valve in the grease line. Be sure that the cylinder collapses to relieve tension in the crawler chain (Fig. 163).



### conveyor chain installation

To install the conveyor chain (Fig. 167):

- ☞ Ensure that the cutting head is adequately blocked.

#### **WARNING!**

**Observe the safe working load limits of all blocking devices. You can be seriously injured or killed by falling loads.**

- ☞ Lay the new chain, uncoiled and upside down, behind the conveyor with the nearest end near the tail roller.

#### **NOTICE!**

**The conveyor chain does not have a right or wrong running directions, only a correct up and down side. The flat side of the flight chains must run on the deck.**

- ☞ Connect the pulling cable (attached to the old chain still in the machine) to the nearest end of the new conveyor chain.
- ☞ Pull the conveyor chain under the tail roller and through the return deck, stopping when the chain reaches the foot shaft.
- ☞ Pull the conveyor chain up over the foot shaft sprocket and lay it in the gathering pan.
- ☞ Disconnect the pulling cable from the front end of the chain and run it along the top conveyor deck to the back of the miner.
- ☞ Connect the pulling cable to the other end of the conveyor chain on the mine floor. Pull it over the tail roller, through the conveyor deck, and up to the other end of the chain on the gathering pan.
- ☞ Connect the chain using a connecting pin and two retaining pins. bend the retaining pins opposite the direction of conveyor chain travel.
- ☞ Close the bleed valve in the conveyor chain take-up circuit so that the circuit can be pressurized when power is reapplied.

#### **WARNING!**

**Make sure all personnel are clear of the miner before performing the following checks. Do not stand behind the conveyor when the chain is running.**

- ☞ Connect the trailing cable to energize the miner.
- ☞ Start the pump motor.
- ☞ Swing the discharge conveyor full right and left to ensure that the chain is clear.
- ☞ Turn on the gathering head motors to run the conveyor. Elevate the conveyor full up and down and swing the discharge conveyor full left and right and check that the chain is running smoothly.

---

## Replacement of wear parts



- ☞ Install a flexible sideboard on each side of the conveyor. Secure with carriage bolts and heavy elastic stop nuts.
- ☞ Connect the trailing cable to energize the miner.
- ☞ Raise the conveyor and remove the blocking.
- ☞ Operate the conveyor raise, lower, swing left, and swing right functions and check for smooth operation.



### Gathering head float

- ☞ Check the control valve for proper operation.
- ☞ Check to see that piping has not been crossed, especially if the problem occurs after maintenance or repair work.
- ☞ Check to see that there is no mechanical bind.
- ☞ Check accumulator for 500 psi pre-charge, and that the bladder is functioning properly.
- ☞ Check cylinders for bypassing (they will leak out the top).
- ☞ Check needle valve on pilot circuit to verify that it is not open or leaking off.
- ☞ Check counterbalance valve for proper operation (see the schematic in the Bucyrus America, Inc. parts book supplied with your machine for the proper setting).

### Conveyor Raise

- ☞ Check the directional control valve for proper operation.
- ☞ Check to see that piping has not been crossed, especially if the problem occurs after maintenance or repair work.
- ☞ Be sure that the built-in atmospheric-vented reliefs on the cylinders are not dumping oil.
- ☞ Check to see that there is no mechanical bind.
- ☞ Verify that cylinders are not bypassing.

### Conveyor Lower

- ☞ Check the directional control valve for proper operation.
- ☞ Check to see that piping has not been crossed, especially if the problem occurs after maintenance or repair work.
- ☞ Verify that pilot pressure is being applied to open the piloted built-in checks.
- ☞ Verify that cylinders are not bypassing.

### Conveyor Swing

- ☞ Check the directional control valve for proper operation.
- ☞ Check for any mechanical bind or any obstruction blocking movement, either to the cylinder itself, the main pivot area, or to some point along or under the discharge conveyor itself. Also check to ensure that the pivot bushings have not frozen up from lack of lubrication.
- ☞ Verify that the cylinder is not bypassing.



## Electrical System

**Table 10: Electrical system troubleshooting**

Trouble, symptom or cause	Probable cause	Test, check and/or remedy
<b>motor contact chatter</b>	<ul style="list-style-type: none"> <li>☞ Low voltage</li> <li>☞ Poor contact in control circuit.</li> <li>☞ Loose wiring connections.</li> <li>☞ Broken shading coil.</li> </ul>	<ul style="list-style-type: none"> <li>☞ Check supply voltage, especially during starting. Check coil voltage rating. Increase voltage or change coil rating as required.</li> <li>☞ Replace the contact or use holding-circuit interlock. (3-wire control)</li> <li>☞ Check wiring connections.</li> <li>☞ Replace magnet and armature assemblies.</li> </ul>
<b>welding of motor contactor tips</b>	<ul style="list-style-type: none"> <li>☞ Abnormal in rush current.</li> <li>☞ Rapid jogging.</li> <li>☞ Insufficient contact pressure.</li> <li>☞ Incorrect vacuum contactor gap.</li> <li>☞ Low voltage preventing magnet from sealing.</li> <li>☞ Foreign matter preventing contacts from closing.</li> <li>☞ Vibration in starter mounting.</li> <li>☞ Short circuit.</li> </ul>	<ul style="list-style-type: none"> <li>☞ Use the next larger size contactor or check for grounds, shorts or excessive motor current.</li> <li>☞ Install larger device rated for jogging service.</li> <li>☞ Replace contacts and springs, check for contacts for abnormal wear or damage.</li> <li>☞ Use the over-travel gauge mounted on the front of the unit. When the gap on the bottle goes below 0.010 inches, the unit should be replaced.</li> <li>☞ Check supply voltage to coil, especially for momentary voltage dip during starting.</li> <li>☞ Clean contacts with Freon. Contacts used at low current and voltage levels should be cleaned with Freon.</li> <li>☞ Insulate starter from shock and vibration.</li> <li>☞ Remove fault and check to be sure fuse or breaker size is correct.</li> <li>☞ For vacuum contactor: after a short circuit examine vacuum bottles, conductor bars, and cables for physical damage. Check over-travel on vacuum bottle.</li> </ul>
<b>short contact life or overheating of motor contactor</b>	<ul style="list-style-type: none"> <li>☞ Filing or dressing.</li> <li>☞ Interrupting excessively high currents.</li> <li>☞ Excessive jogging.</li> <li>☞ Weak contact pressure.</li> <li>☞ Foreign matter on contact surface.</li> </ul>	<ul style="list-style-type: none"> <li>☞ <u>Do not file silver contacts.</u> Rough spots or discoloration will not harm contacts or impair their efficiency.</li> <li>☞ Install larger unit. Check for grounds, shorts or excessive motor currents.</li> <li>☞ Install larger unit rated for jogging service.</li> <li>☞ Replace contacts and springs. Check contacts for abnormal wear or damage.</li> <li>☞ Clean contacts with Freon. Take steps to reduce entry of foreign matter into enclosure.</li> </ul>

© BUCYRUS AMERICA, INC.



**Table 12: Control system error codes, continued**

Fault Number/Name/Description	Possible cause	Check
<p><b>0035</b> <b>Second Remote Console Detected</b></p> <p>A second transmitter serial number was detected on the same channel in close proximity to the machine. All functions disabled. machine power must be cycled.</p>	<ul style="list-style-type: none"> <li>- Second radio remote console was turned on and brought within radio range of the machine.</li> </ul>	<ol style="list-style-type: none"> <li>1. Ensure that only one radio remote console is being used within 400 meters of the machine.</li> </ol>
<p><b>0036</b> <b>Left Machine Stop Pressed</b></p> <p>The left side machine stop button is pressed.</p>	<ul style="list-style-type: none"> <li>- Left side machine stop is currently pressed.</li> <li>- Digital input A8-DD is not connected to 120VAC ACTIVE.</li> <li>- Neutral Reference Pin A8-n does not have 120VAC Neutral connected.</li> <li>- Faulty Relay I/O Module.</li> </ul>	<ol style="list-style-type: none"> <li>1. Reset the left side machine stop button.</li> <li>2. Check that there is 120VAC active to pin A8-DD when the left top button is in the reset position.</li> <li>3. Check that there is no broken wiring between the stop switch and pin A8-DD.</li> <li>4. Ensure that 120VAC NEUTRAL is connected to pin A8-n.</li> <li>5. Replace the Relay I/O Module.</li> </ol>
<p><b>0037</b> <b>Operator Case Machine Stop Pressed</b></p> <p>The operator case machine stop button is pressed.</p>	<ul style="list-style-type: none"> <li>- Operator case machine stop is currently pressed.</li> <li>- Digital input A8-z is not connected to 120VAC ACTIVE.</li> <li>- Neutral Reference Pin A8-n does not have 120VAC NEUTRAL connected.</li> <li>- Faulty Relay I/O Module.</li> </ul>	<ol style="list-style-type: none"> <li>1. Reset the operator case machine stop button.</li> <li>2. Check that there is 120VAC active to pin A8-z when the left top button is in the reset position.</li> <li>3. Check that there is no broken wiring between the stop switch and pin A8-z.</li> <li>4. Ensure that 120VAC NEUTRAL is connected to pin A8-n.</li> <li>5. Replace the Relay I/O Module.</li> </ol>
<p><b>0038</b> <b>Traction Transformer Earth Leakage</b></p> <p>The earth-leakage relay that is monitoring the traction transformer is in the tripped state. The control system monitors the relay using input A8-y. If this input is not connected to 120VAC ACTIVE, the control system assumes that the relay is tripped.</p>	<ul style="list-style-type: none"> <li>- Traction earth leakage condition exists.</li> <li>- Faulty traction earth leakage relay (or wrong adjustment).</li> <li>- Digital input A8-y is not connected to 120VAC ACTIVE.</li> <li>- Neutral Reference Pin A8-t does not have 120VAC NEUTRAL connected.</li> <li>- Faulty Relay I/O Module.</li> </ul>	<ol style="list-style-type: none"> <li>1. Check for earth leakage in the traction transformer.</li> <li>2. Check that the earth leakage relay is working properly and is adjusted correctly.</li> <li>3. Check that there is 120VAC ACTIVE to pin A8-y when the traction earth leakage relay is in the healthy state.</li> <li>4. Check that there is not broken wiring between the relay and pin A8-y.</li> <li>5. Ensure that 120VAC NEUTRAL is connected to pin A8-t.</li> <li>6. Replace the Relay I/O Module.</li> </ol>



**Table 12: Control system error codes, continued**

Fault Number/Name/Description	Possible cause	Check
<p><b>0075</b> <b>Left Traction RTD Over Temp</b></p> <p>Motor temperature detected above 145C (per the RTD temperature sensor). RTD resistance is between 155 and 158 Ohms.</p>	<ul style="list-style-type: none"> <li>- Motor has overheated.</li> <li>- RTD failure (DO NOT MEGGAR).</li> <li>- Cable damage.</li> <li>- Thermistor module failure.</li> <li>- Motor failure.</li> </ul>	<ol style="list-style-type: none"> <li>1. Check motor.</li> <li>2. Check condition of wiring to RTD circuit and measure RTD resistance and compare to chart. Note: Check connections in motor cable junction boxes.</li> <li>3. Connect spare RTD circuit in motor terminal enclosure.</li> <li>4. Replace Thermistor Module.</li> <li>5. Replace motor.</li> <li>6. Check pilot cores in motor supply cable. If pilot cores are damaged, replace cable.</li> </ol>
<p><b>0076</b> <b>Left Traction Motor RTD Open Circuit</b></p> <p>RTD temperature sensor in motor has a resistance equal or greater than a resistance of 150C (greater than 158 Ohms). RTD circuit is probably open.</p>	<ul style="list-style-type: none"> <li>- Resistance in RTD circuit is above 158 Ohms.</li> <li>- RTD failure (DO NOT MEGGAR).</li> <li>- Cable damage.</li> <li>- Thermistor module failure.</li> <li>- Motor failure.</li> </ul>	<ol style="list-style-type: none"> <li>1. Check condition of wiring to RTD circuit and measure RTD resistance and compare to chart. Note: Check connections in motor cable junction boxes.</li> <li>2. Connect spare RTD circuit in motor terminal enclosure.</li> <li>3. Replace Thermistor Module.</li> <li>4. Replace motor.</li> <li>5. Check pilot cores in motor supply cable. If pilot cores are damaged, replace cable.</li> </ol>
<p><b>0077</b> <b>Right Traction Motor RTD Short Circuit</b></p> <p>RTD temperature sensor in transformer has low resistance or short circuit (below 80 Ohms).</p>	<ul style="list-style-type: none"> <li>- Resistance in RTD circuit is below 80 Ohms.</li> <li>- RTD failure (DO NOT MEGGAR).</li> <li>- Cable damage.</li> <li>- Thermistor module failure.</li> <li>- Motor failure.</li> </ul>	<ol style="list-style-type: none"> <li>1. Check condition of wiring to RTD circuit and measure RTD resistance and compare to chart. Note: Check connections in motor cable junction boxes.</li> <li>2. Connect spare RTD circuit in motor terminal enclosure.</li> <li>3. Replace Thermistor Module.</li> <li>4. Replace motor.</li> <li>5. Check pilot cores in motor supply cable. If pilot cores are damaged, replace cable.</li> </ol>

© BUCYRUS AMERICA, INC.



**Table 13: Control system fault codes, continued**

Fault Number/Name/Description	Possible cause	Check
<p><b>0225</b> <b>Left Gath Head Motor Mate Failure</b></p> <p>At least one of the three signal lines from the motor mate is faulty, while the left gathering head motor was running or an attempt was made to start the motor. Each signal line must read between 4 mA and 20 mA to be normal. If any of the lines is not in this range, this fault will occur. The gathering motors were shut-down.</p>	<ul style="list-style-type: none"> <li>- Loss of 24VDC supply to the Motor Mate.</li> <li>- One or more signal lines have gone open circuit,</li> <li>- One or more signal lines have been shorted.</li> <li>- Motor Mate is faulty.</li> <li>- Relay I/O Module is faulty (interface to the Motor Mate).</li> </ul>	<ol style="list-style-type: none"> <li>1. Check 24VDC supply wiring is OK (+24VDC line is provided by output pin A8-B on the Relay I/O Module).</li> <li>2. Check that each signal line is not open or short circuit.</li> <li>3. Replace the Motor Mate.</li> <li>4. Replace the Relay I/O Module.</li> </ol>
<p><b>0226</b> <b>Right Cutter Motor Mate Failure</b></p> <p>At least one of the three signal lines from the motor mate is faulty, while the right gathering head motor was running or an attempt was made to start the motor. Each signal line must read between 4 mA and 20 mA to be normal. If any of the lines is not in this range, this fault will occur. The gathering motors were shut-down.</p>	<ul style="list-style-type: none"> <li>- Loss of 24VDC supply to the Motor Mate.</li> <li>- One or more signal lines have gone open circuit,</li> <li>- One or more signal lines have been shorted.</li> <li>- Motor Mate is faulty.</li> <li>- Relay I/O Module is faulty (interface to the Motor Mate).</li> </ul>	<ol style="list-style-type: none"> <li>1. Check 24VDC supply wiring is OK (+24VDC line is provided by output pin A8-B on the Relay I/O Module).</li> <li>2. Check that each signal line is not open or short circuit.</li> <li>3. Replace the Motor Mate.</li> <li>4. Replace the Relay I/O Module.</li> </ol>
<p><b>0227</b> <b>Scrubber Motor Mate Failure</b></p> <p>At least one of the three signal lines from the motor mate is faulty, while the scrubber was running or an attempt was made to start the motor. Each signal line must read between 4 mA and 20 mA to be normal. If any of the lines is not in this range, this fault will occur. The gathering motors were shutdown.</p>	<ul style="list-style-type: none"> <li>- Loss of 24VDC supply to the Motor Mate.</li> <li>- One or more signal lines have gone open circuit.</li> <li>- One or more signal lines have been shorted.</li> <li>- Motor Mate is faulty.</li> <li>- Relay I/O Module is faulty (interface to the Motor Mate).</li> </ul>	<ol style="list-style-type: none"> <li>1. Check 24VDC supply wiring is OK (+24VDC line is provided by output pin A8-B on the Relay I/O Module).</li> <li>2. Check that each signal line is not open or short circuit.</li> <li>3. Replace the Motor Mate.</li> <li>4. Replace the Relay I/O Module.</li> </ol>
<p><b>0228</b> <b>Voltage Transducer Failure</b></p> <p>The signal from the voltage transducer was not healthy (healthy level is between 4 mA and 20 mA). All motors and functions shutdown.</p>	<ul style="list-style-type: none"> <li>- Supply to transducer (24VDC) is not present.</li> <li>- Broken or short circuit signal wire from transducer to the Relay I/O Module.</li> <li>- Internal transducer failure.</li> <li>- Internal failure of the Relay I/O Module.</li> </ul>	<ol style="list-style-type: none"> <li>1. Check 24VDC is present at transducer.</li> <li>2. Check signal line from transducer to the Relay I/O Module.</li> <li>3. Replace the transducer.</li> <li>4. Replace the Relay I/O Module (if signal &gt; 4 MA from transducer).</li> </ol>
<p><b>0229</b> <b>Machine Voltage Too Low</b></p> <p>Machine voltage detected below MIN VOLTAGE setting in setup menu. All motors and functions shutdown.</p>	<ul style="list-style-type: none"> <li>- Mine power supply voltage too low.</li> <li>- Control transformer faulty.</li> <li>- Voltage transducer faulty.</li> <li>- Relay I/O Module faulty.</li> </ul>	<ol style="list-style-type: none"> <li>1. Measure machine voltage/control voltage.</li> <li>2. Check control transformer input/output.</li> <li>3. Replace the voltage transducer.</li> <li>4. Replace the Relay I/O Module.</li> </ol>
<p><b>0230</b> <b>Machine Voltage Too High</b></p> <p>Machine voltage detected above MAX VOLTAGE setting in setup menu. All motors and functions shutdown.</p>	<ul style="list-style-type: none"> <li>- Mine power supply voltage too high.</li> <li>- Control transformer faulty.</li> <li>- Voltage transducer faulty.</li> <li>- Relay I/O Module faulty.</li> </ul>	<ol style="list-style-type: none"> <li>1. Measure machine voltage/control voltage.</li> <li>2. Check control transformer input/output.</li> <li>3. Replace the voltage transducer.</li> <li>4. Replace the Relay I/O Module.</li> </ol>

© BUCYRUS AMERICA, INC.



**Table 13: Control system fault codes, continued**

Fault Number/Name/Description	Possible cause	Check
<p><b>0274</b> <b>No Right Cutter Current Detected at Startup</b></p> <p>When trying to start the Right Cutter Motor, there was no current detected in the motor. The motor contactor was shutdown.</p>	<ul style="list-style-type: none"> <li>- Contactor lost 120VAC to contactor coil</li> <li>- Contactor has failed.</li> <li>- Current transformer for motor has failed.</li> <li>- Analog input board within the Remote I/O Module has failed.</li> <li>- Power wiring failure/motor failure.</li> </ul>	<ol style="list-style-type: none"> <li>1. Check for loose 120VAC wiring to contactor's coil. Check for open mini circuit breaker that feeds 120VAC to contactor outputs or contactor commons.</li> <li>2. If contactor gets 120VAC to its coil but doesn't pull in, replace contactor.</li> <li>3. Check 24VDC that feeds the current transformer. If contactor gets 120VAC to its coil and the contactor pulls in but the transformer does not create a feedback to the Remote I/O Module between 4 and 20 mA, replace the current transformer.</li> <li>4. If contactor pulls in and current transformer is creating a proper feedback to the Processor Module but the color display does not show a non-zero current for the motor, replace the Remote I/O module.</li> <li>5. If contactor pulls in, does the motor rotate or start to rotate before the machine trips? If no, is voltage getting to the associated motor? No voltage to motor - power wiring failure. Voltage to motor but no movement - motor failure.</li> </ol>
<p><b>0275</b> <b>Left Cutter Current Did Not Stabilize on Startup</b></p> <p>Note: Not Possible</p> <p>Reserved for future use.</p>	TBA	TBA
<p><b>0276</b> <b>Right Cutter Current Did Not Stabilize on Startup</b></p> <p>Note: Not Possible</p> <p>Reserved for future use.</p>	TBA	TBA
<p><b>0277</b> <b>Left Cutter RTD Short Circuit</b></p> <p>RTD temperature sensor in motor has low resistance or short circuit (below 80 Ohms). Cutter motors shutdown and prevented from starting.</p>	<ul style="list-style-type: none"> <li>- Resistance in RTD circuit is below 80 Ohms.</li> <li>- RTD failure (DO NOT MEGGAR).</li> <li>- Cable damage.</li> <li>- Thermistor Module failure.</li> <li>- Motor failure.</li> </ul>	<ol style="list-style-type: none"> <li>1. Check condition of wiring to RTD circuit and measure RTD resistance and compare to chart.  Note: Check connections in motor cable junction boxes.</li> <li>2. Connect spare RTD circuit in motor terminal enclosure.</li> <li>3. Replace Thermistor Module.</li> <li>4. Replace motor.</li> <li>5. Check pilot cores in motor supply cable. If pilot cores are damaged, replace cable.</li> </ol>



**Table 13: Control system fault codes, continued**

Fault Number/Name/Description	Possible cause	Check
<p><b>0306</b> <b>Left Gath Phase Loss</b></p> <p>While the left gathering motor was running, at least one of the phase currents went to 0 Amps for unknown reasons. It is possible that the motor lead is not connected from the motor. It is also possible that the motor has a serious internal failure. The gathering motors were shutdown.</p>	<ul style="list-style-type: none"> <li>- Motor cable has gone open circuit.</li> <li>- Motor failure.</li> <li>- One phase of contactor is faulty.</li> <li>- Motor Mate faulty.</li> <li>- Faulty Relay I/O Module.</li> </ul>	<ol style="list-style-type: none"> <li>1. Check motor cables.</li> <li>2. Check the motor.</li> <li>3. Check the contactor (all phases).</li> <li>4. Check the Motor Mate is OK.</li> <li>5. Check that the Relay I/O Module is OK.</li> </ol>
<p><b>0307</b> <b>Left Gath Phase Imbalance</b></p> <p>While the left gathering motor was running, a significant difference in the phase currents was detected. Normally, all three phase currents for a motor should be approximately equal. The gathering motors were shutdown.</p>	<ul style="list-style-type: none"> <li>- High voltage supply to the machine is imbalanced.</li> <li>- Motor failure.</li> <li>- Motor mate is faulty.</li> <li>- Relay I/O Module is faulty.</li> </ul>	<ol style="list-style-type: none"> <li>1. Check the high voltage supply to the machine.</li> <li>2. Check the motor.</li> <li>3. Check that the Motor Mate is OK.</li> <li>4. Check that the Relay I/O Module is OK.</li> </ol>
<p><b>0308</b> <b>Left Gath Instantaneous Overload</b></p> <p>While the left gathering motor was running, the current measured in the motor exceeded the instantaneous overload threshold. The gathering motors were shutdown.</p>	<ul style="list-style-type: none"> <li>- Jammed gear box or shaft.</li> <li>- Loaders or conveyors under heavy load.</li> <li>- Left gathering head motor has failed.</li> </ul>	<ol style="list-style-type: none"> <li>1. Check that the gathering head is not overloaded.</li> <li>2. Check that the conveyor is not overloaded.</li> <li>3. Check gear box and shaft.</li> <li>4.. Check the motor.</li> </ol>
<p><b>0309</b> <b>Left Gath Thermal Overload</b></p> <p>The left gathering motor current was too high for too long a period. This can cause overheating and possible motor damage. The gathering motors were shutdown and prevented from starting for several minutes to prevent motor damage.</p>	<ul style="list-style-type: none"> <li>- Heavy cutting and loading activity for an extended period.</li> <li>- Damaged gear box or shaft.</li> <li>- Left gathering head motor damaged.</li> </ul>	<ol style="list-style-type: none"> <li>1. Check that the gathering head is not overloaded.</li> <li>2. Check that the conveyor is not overloaded.</li> <li>3. Check gear box and shaft.</li> <li>4.. Check the motor.</li> </ol>
<p><b>0310</b> <b>Right Gath Phase Loss</b></p> <p>While the right gathering motor was running, at least one of the phase currents went to 0 Amps for unknown reasons. It is possible that the motor lead is not connected from the motor. It is also possible that the motor has a serious internal failure. The gathering motors were shutdown.</p>	<ul style="list-style-type: none"> <li>- Motor cable has gone open circuit.</li> <li>- Motor failure.</li> <li>- One phase of contactor is faulty.</li> <li>- Motor Mate faulty.</li> <li>- Faulty Relay I/O Module.</li> </ul>	<ol style="list-style-type: none"> <li>1. Check motor cables.</li> <li>2. Check the motor.</li> <li>3. Check the contactor (all phases).</li> <li>4. Check the Motor Mate is OK.</li> <li>5. Check that the Relay I/O Module is OK.</li> </ol>



**Table 13: Control system fault codes, continued**

Fault Number/Name/Description	Possible cause	Check
<p><b>0364</b> <b>Left Drive - Internal Sync Loss</b></p> <p>The left traction drive failed to synchronize with the incoming power frequency. the drive is not able to control the traction motor.</p>	<ul style="list-style-type: none"> <li>- Faulty traction drive.</li> </ul>	<ol style="list-style-type: none"> <li>1. Check traction drive.</li> </ol>
<p><b>0365</b> <b>Left Drive - Loss of Incoming 3 Phase</b></p> <p>There was a loss of 3 phase power to the input stage of the left traction drive.</p>	<ul style="list-style-type: none"> <li>- Loose power cable connections to drive.</li> <li>- Faulty traction transformer.</li> <li>- Faulty traction drive.</li> </ul>	<ol style="list-style-type: none"> <li>1. Check power cables.</li> <li>2. Check transformer.</li> <li>3. Check traction drive.</li> </ol>
<p><b>0366</b> <b>Left Drive - Loss of CAN Comms</b></p> <p>The left traction drive is reporting a failure of CAN communications.</p>	<ul style="list-style-type: none"> <li>- Failure of CAN-bus wiring to the module.</li> <li>- Short circuit or open circuit of data cable that connects to the module.</li> <li>- Internal failure of the left traction drive motor.</li> </ul>	<ol style="list-style-type: none"> <li>1. Check the integrity of the data cable.</li> <li>2. Check all connections to both drives and to the control system processor module.</li> <li>3. Check that there are not short circuits of the CAN bus wiring.</li> <li>4. Replace the left traction drive motor.</li> </ol>
<p><b>0367</b> <b>Left Drive - Unplanned Movement</b></p> <p>When the left tram motor should have been off, the left drive detected illegal current in the motor.</p>	<ul style="list-style-type: none"> <li>- Faulty traction drive.</li> </ul>	<ol style="list-style-type: none"> <li>1. Check traction drive.</li> </ol>
<p><b>0368</b> <b>Left Drive - ETRAM Mode</b></p> <p>The left traction drive is reporting that it has been placed in E-tram mode. This is considered a fault because the control system should not have power when e-tram is selected on the machine.</p>	<ul style="list-style-type: none"> <li>- Faulty E-tram selector switch.</li> <li>- Faulty wiring in E-tram electrical system.</li> <li>- Faulty traction drive.</li> </ul>	<ol style="list-style-type: none"> <li>1. Check E-tram switch.</li> <li>2. Check E-tram wiring connections.</li> <li>3. Check traction drive.</li> </ol>
<p><b>0369</b> <b>Left Drive - Drive Not In Ready State</b></p> <p>The left traction drive is reporting that it is not ready for tramping control.</p>	<ul style="list-style-type: none"> <li>- Faulty traction drive.</li> </ul>	<ol style="list-style-type: none"> <li>1. Check traction drive.</li> </ol>
<p><b>0370</b> <b>Right Drive Warning - Low Line Voltage</b></p> <p>Reserved for future use.</p>	TBA	TBA
<p><b>0371</b> <b>Right Drive - Internal Overtemperature</b></p> <p>Reserved for future use.</p>	TBA	TBA
<p><b>0372</b> <b>Right Drive - High Line Voltage</b></p> <p>Reserved for future use.</p>	TBA	TBA



## Permissible media

### Lubrication fluids and greases

#### NOTICE!

Use only lubrication fluids and greases approved by Bucyrus America, Inc. ! These fluids and greases have been tested at Bucyrus America, Inc. and guarantee reliable operation of the mechanical and hydraulic functions of the machine.



#### IMPORTANT!

The lubrication fluids and greases listed in the same table can be mixed. Other products may only be used if the supplier can guarantee that they are equivalent.

Differently composed fluids and greases must not be mixed as this may change the consistency, i.e. the mixture can become thinner so that the lubrication effect is not sufficient. It may also be dangerous to use lubricating greases and fluids having the same specification base but different origins.

In case of doubt, the manufacturer of the lubrication to be used should be contacted as to the compatibility of the lubrication in question.



#### IMPORTANT!

Bucyrus America, Inc. expressly point out that the approval of the listed products relates only to the pure technical use in our mechanical and hydraulic systems. The responsibility for the constituents used in the hydraulic concentrates lies solely with the respective manufacturer.



#### IMPORTANT!

Be sure to use the manufacturer's instructions for use.

#### NOTICE!

When performing maintenance on the machine, all used oil and lubricants should be stored and disposed of per your local EPA standards.

CLICK HERE TO **DOWNLOAD** THE COMPLETE MANUAL

- Thank you very much for reading the preview of the manual.
- You can download the complete manual from: [www.heydownloads.com](http://www.heydownloads.com) by clicking the link below



- Please note: If there is no response to CLICKING the link, please download this PDF first and then click on it.

CLICK HERE TO **DOWNLOAD** THE COMPLETE MANUAL