



Technical Manual

CLICK HERE TO **DOWNLOAD** THE COMPLETE MANUAL

- Thank you very much for reading the preview of the manual.
- You can download the complete manual from: www.heydownloads.com by clicking the link below



- Please note: If there is no response to CLICKING the link, please download this PDF first and then click on it.

CLICK HERE TO **DOWNLOAD** THE COMPLETE MANUAL



Before starting to work

What is the purpose of this operating manual?

cost-effectiveness

This operating manual is intended to help you work efficiently and safely with our product. It contains important information on all the activities related to the machine.

Read this operating manual completely and at ease. Pay special attention to the safety instructions. Try to memorize the appearance and the meaning of the safety and instruction symbols.

service

If any details are not clearly understood, please contact our service department. Our service address is given in the chapter titled "For your information".

safety

Read the chapter "For your safety" with special attention. The chapter contains important information indicating possible hazards. Observe the information given and follow the procedural instructions.



Safety instructions

moving parts

Never allow parts of your body to come between parts which could move, such as e.g.:

- conveyor chains
- flights
- pivot points
- boom assemblies
- crawler assemblies
- breaker shaft assemblies



Overview of safety instructions



WARNING!

The machine should not be started if it's core temperature is below 30° Fahrenheit. If the machine is started at extremely low temperatures pump and pump motor failure could occur.



NOTICE!

The feeder has skid type steering; it is capable of turning within its own limits.



IMPORTANT!

If material is very wet or sticky, it is recommended that the return line be flushed with water and the conveyor be allowed to run and clean out the return line before shutting the machine down.



WARNING!

Before removing the cover from the starter enclosure and attempting any maintenance or troubleshooting on the machine, the main power must be disconnected and locked out at the main power center.



WARNING!

Never disconnect a hydraulic hose if the circuit is pressurized or if there is a load on the circuit. If a hose is disconnected while the circuit is pressurized or a load is on the circuit, the load will fall causing damage to the machine or serious injury or death to you or other workers.



WARNING!

The tilt and lift hydraulic cylinders have counterbalance cartridges which serve as load holding valves. Do not replace these cylinders with different style cylinders or the machine may fall. The machine could be damaged or you or other personnel could be seriously injured or killed by the falling machine.



WARNING!

Before performing maintenance on the machine, the circuit breaker must be in the "OFF" position and the power should be disconnected at the main power source. Electrical shock and accidental machine movement can cause serious injuries or even death to you or the maintenance person.



WARNING!

Do not move any hydraulic control lever unless you are certain that everyone is completely clear of any machine movement. Accidental machine movement can cause serious injuries or even death to you or the maintenance person.



WARNING!

You could be seriously injured or even killed by falling loads. Observe the safe working load limits of lifting or blocking devices and keep a safe distance from suspended loads.





Installing the discharge boom and remote power unit

To install the discharge boom (Fig. 13) on the feeder breaker proceed as follows:



WARNING!

You could be seriously injured or even killed by falling loads. Observe the safe working load limits of lifting or blocking devices and keep a safe distance from suspended loads.

- ☞ Attach an appropriate lifting device to the knuckle joint assembly (item 2) and align mounting holes of knuckle joint assembly with the mounting holes on the rear of the feeder breaker.
- ☞ Secure knuckle joint assembly to the feeder breaker with four (4) pins (item 13), eight (8) flat washers (item 14) and eight (8) cotter pins (item 15).
- ☞ Attach an appropriate lifting device to the discharge section (item 3) and align center mounting hole of frame with center hole in knuckle joint.
- ☞ Secure discharge section to knuckle joint with swivel pin (item 8), flat washer (item 9), lock nut (item 10), and cotter pin (item 11).
- ☞ Weld keeper pin (item 12) in place with .25" (6.35 mm) (3 places to prevent rotation of swivel pin).
- ☞ Attach an appropriate lifting device to steering cylinder (item 4) align with steering clevis's on knuckle joint and discharge boom. Insure that rod end of steering cylinder is towards discharge boom.
- ☞ Secure each end of steering cylinder with one (1) pin (item 5), two (2) flat washers (item 6) and (2) cotter pins (item 7).
- ☞ Repeat steps for opposite side steering cylinder.
- ☞ Refer to hydraulic schematic in parts manual for hydraulic hosing of discharge boom and remote power unit.
- ☞ Refer to electrical schematic in parts manual for electrical connections of remote power unit.



Operation

Fig. 16: Controls and indicators

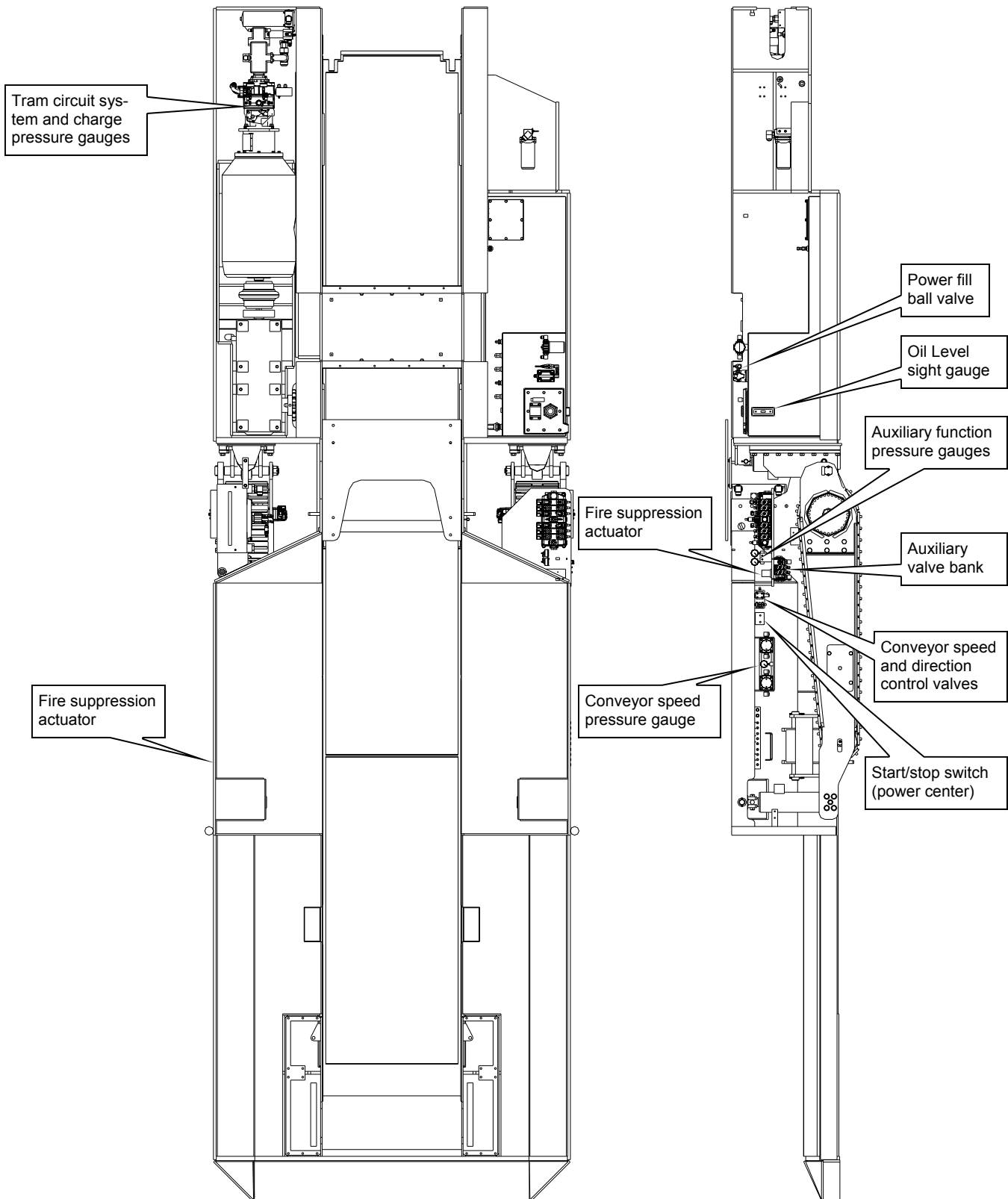

© DBT AMERICA 2007



Operation

© DBT AMERICA 2007



Hydraulic system

Fig. 27: Hydraulic schematic feeder breaker

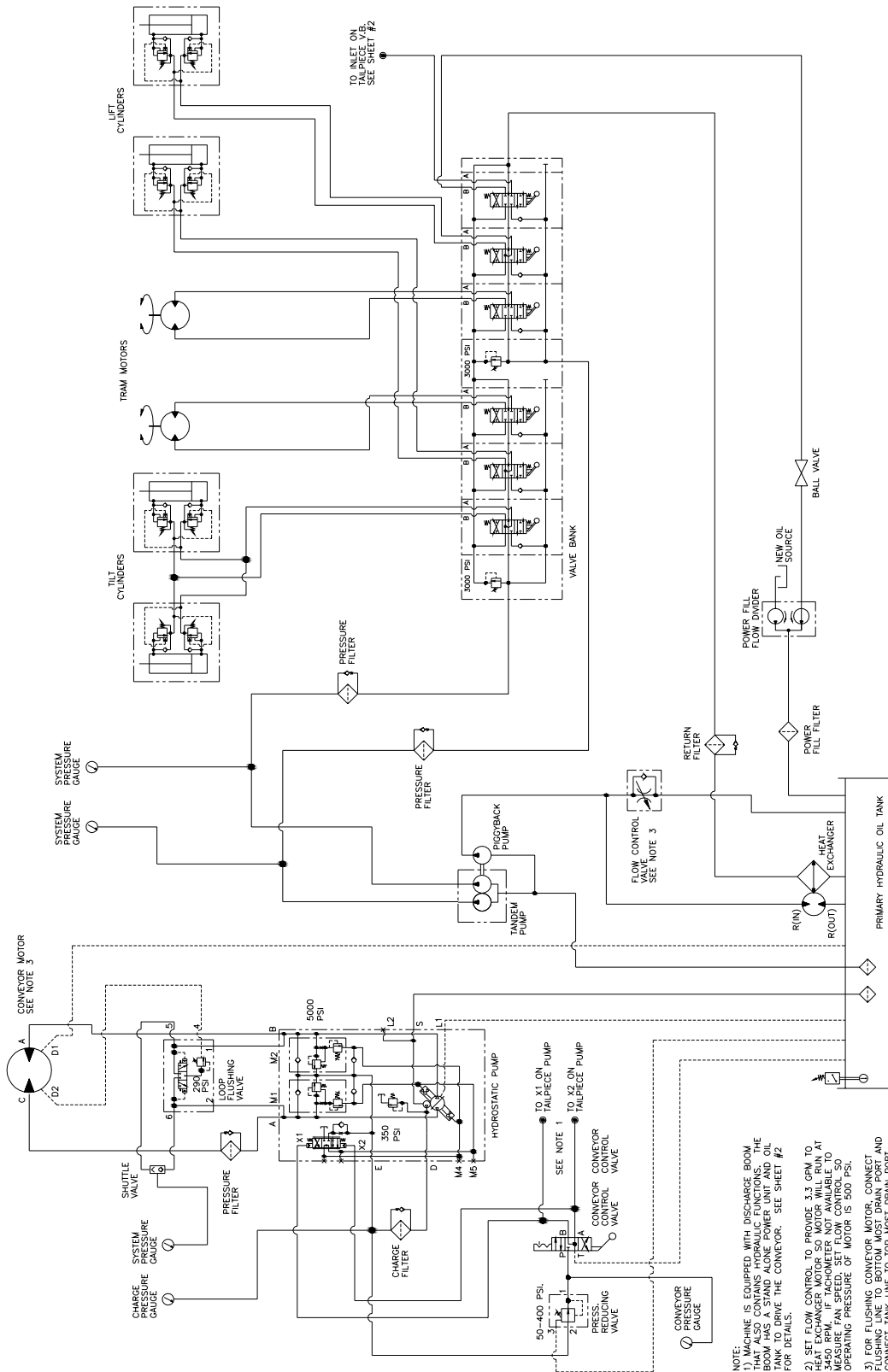

© DBT AMERICA 2007

CLICK HERE TO **DOWNLOAD** THE COMPLETE MANUAL

- Thank you very much for reading the preview of the manual.
- You can download the complete manual from: www.heydownloads.com by clicking the link below



- Please note: If there is no response to CLICKING the link, please download this PDF first and then click on it.

CLICK HERE TO **DOWNLOAD** THE COMPLETE MANUAL



Maintenance

- During maintenance or servicing, if either of the tram drives are to be run, the side that is to be run must be jacked clear of the ground and securely blocked.
- Do not perform maintenance on either boom while there is a load resting on the hydraulic cylinder. Booms must be securely blocked if maintenance is to be performed with either boom in the raised position.



WARNING!

Never disconnect a hydraulic hose if the circuit is pressurized or if there is a load on the circuit. If a hose is disconnected while the circuit is pressurized or a load is on the circuit, the load will fall causing damage to the machine or serious injury or death to you or other workers



WARNING!

You could be seriously injured or even killed by falling loads. Observe the safe working load limits of lifting or blocking devices and keep a safe distance from suspended loads.

- Do not perform maintenance in a congested area. This could endanger the maintenance person or others in the vicinity.
- Whenever a potential problem is uncovered during a periodic maintenance check, it is imperative that it be corrected immediately by a qualified maintenance technician.
- Cleanliness can not be overemphasized as the essential ingredient of a good maintenance program. Machines should be kept as free as possible of dirt and debris which could impede performance or infiltrate systems and cause premature wear or failure.



Maintenance

charge filter Change the charge filter element (Fig. 47). If the element is extremely dirty, a more frequent interval may be required.

hydraulic system pressure (s) Check the hydraulic system pressure (s) by visually looking at the pressure gauges (Fig. 47). Refer to the hydraulic schematic in your parts manual for correct pressure (s).

Fig. 47: Hydraulic charge filter and system pressure gauges (s) location

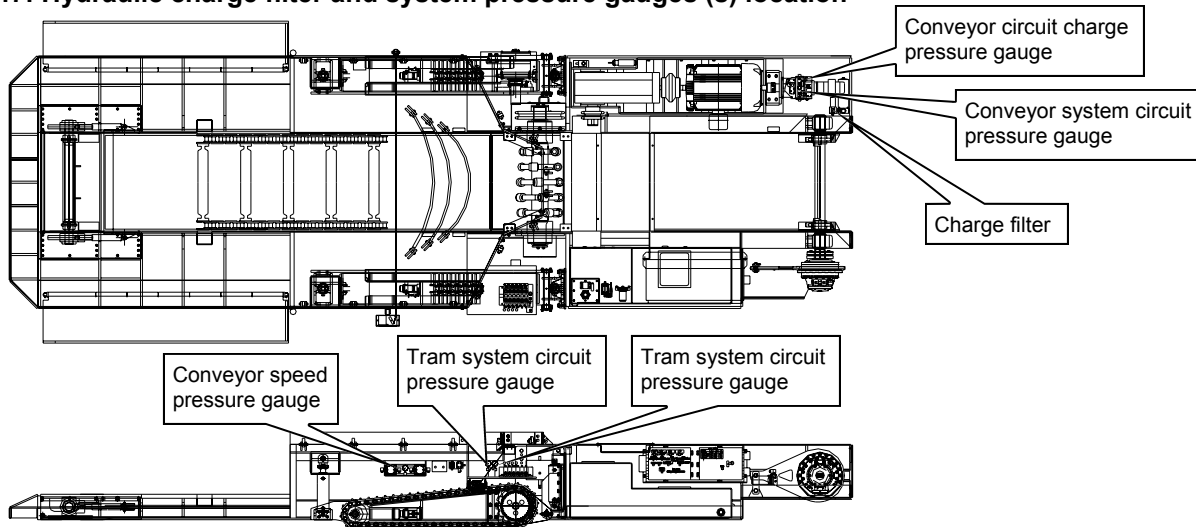

tram reducer (s) Check the oil level in both tram reducer torque hubs (Fig. 48):

- ☞ Oil level/fill plug should be at the 3 o'clock and 12 o'clock position.
- ☞ Remove the oil level/fill plugs.
- ☞ The oil level should be kept at the level of the level/fill plug.
- ☞ Should it be necessary to add oil, add 80W-90 oil through the fill plug hole until it begins to flow out of the check hole.
- ☞ Do not overfill the reducer.

Fig. 48: Tram reducer oil level

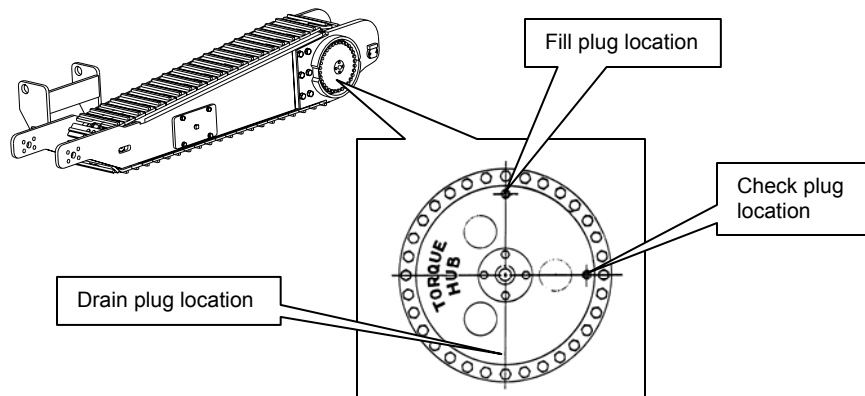

© DBT AMERICA 2007



Maintenance

hydraulic oil tank

Change the hydraulic fluid in the remote power unit oil tank (Fig. 60).

- ☞ Clean all dirt and debris from and around the fill cap and drain plug.
- ☞ Remove the drain plug and allow the oil tank to completely drain.
- ☞ Clean and reinstall drain plug.
- ☞ Add oil Spec 100-1 as required via the hand pump until fluid is visible in sight glass.
- ☞ Install fill cap.
- ☞ Start the power unit and allow the hydraulic pump to run in order to purge air from the system.
- ☞ Shut down the power unit and recheck the oil level. Add oil if necessary.

Fig. 60: Remote power unit oil tank

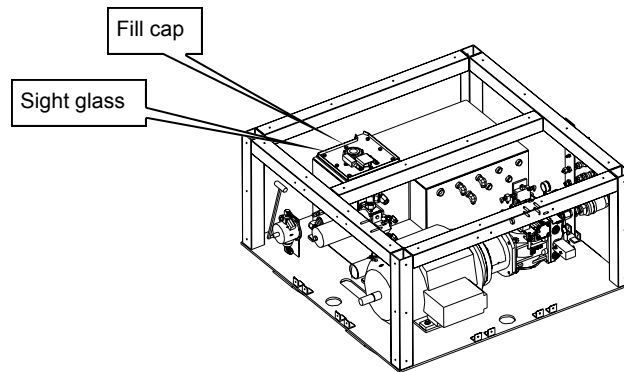



Adjustment procedures

Fig. 63: Crawler track adjustment

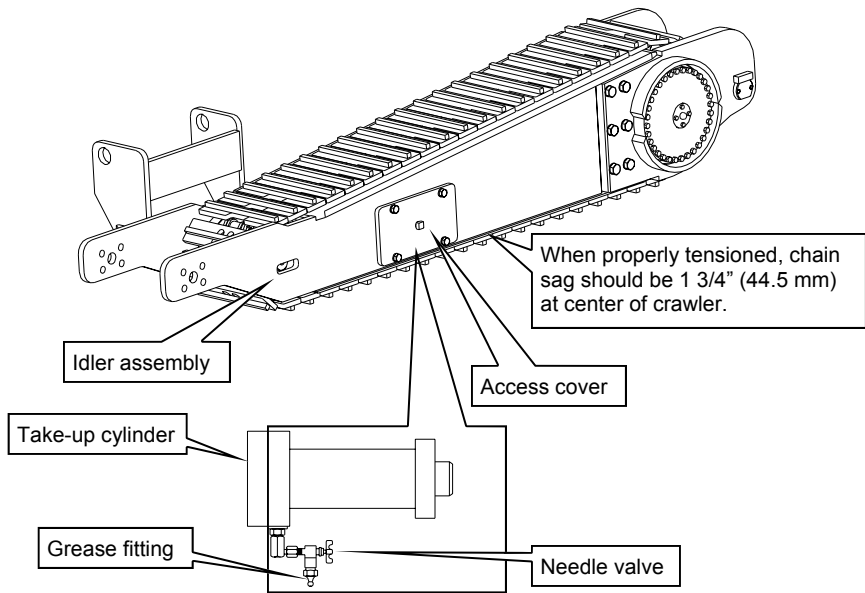

© DBT AMERICA 2007



Replacement of wear parts

Fig. 69: Tail shaft removal and installation

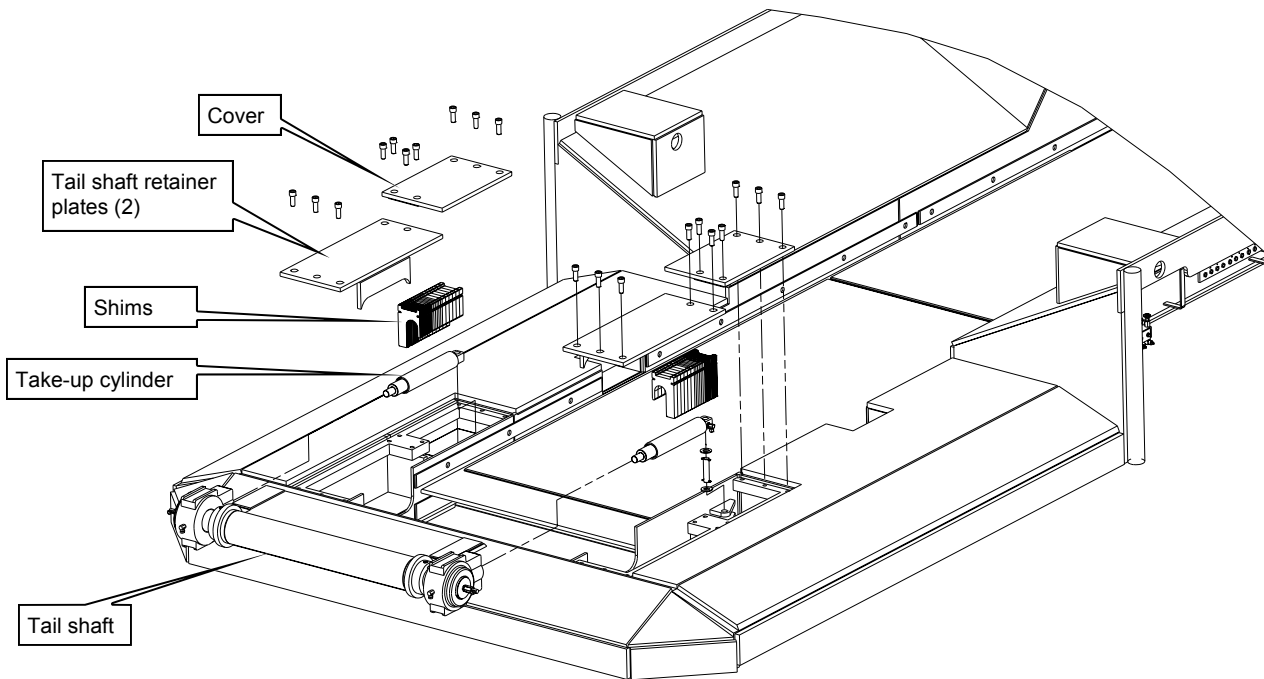

© DBT AMERICA 2007



Replacement of wear parts

How to remove the crawler take-up assembly

To remove the crawler take-up assembly proceed as follows (Fig. 75):

- ☞ Raise complete crawler assembly off ground and securely block under the machine. The machine must be securely supported off the ground with the crawler free to turn.



WARNING!

You could be seriously injured or even killed by falling loads. Observe the safe working load of the lifting and blocking devices and keep a safe distance away from suspended loads.

- ☞ Crawler track tension must be released (see Crawler track adjustment in this chapter).
- ☞ Separate the crawler pads (see How to remove the crawler track assembly in this chapter) and fold pads back to clear take-up.
- ☞ Securely block under the crawler frame.
- ☞ Disconnect, tag and cap hydraulic hoses going to the tilt cylinder.



WARNING!

Never disconnect a hydraulic hose if the circuit is pressurized or if there is a load on the circuit. If a hose is disconnected while the circuit is pressurized or a load is on the circuit, the load will fall causing damage to the machine or serious injury or death to you or other workers

- ☞ Remove the eight (8) bolts from the tilt cylinder mounting bracket.
- ☞ swing the tilt cylinder and mounting bracket free of the crawler frame.
- ☞ Connect an additional pulling or lifting device (e.g. winch or lifting tackle with adequate load limit) to the take-up assembly and slowly pull the assembly out of the crawler frame.



WARNING!

When using an additional pulling device (e.g. winch or lifting tackle with adequate load limit) for pulling the take-up, the connection could fracture under the load. You could be seriously injured or killed by the recoiling chain or cable. Use only approved lifting equipment for connecting pulling devices to the take-up.

- ☞ Inspect all components for wear or damage.



Replacement of wear parts

- ☞ Remove the three (3) bolts that secures the taper lock (item 4) to the motor shaft.
- ☞ Insert two (2) of the bolts removed from the taper lock into the jack screw threaded holes located in the end of the taper lock (Fig. 79). Tighten both bolts equally until the taper lock is free from motor shaft
- ☞ Visually inspect all components for wear or damage and replace if necessary.

Fig. 79: Taper lock removal and installation

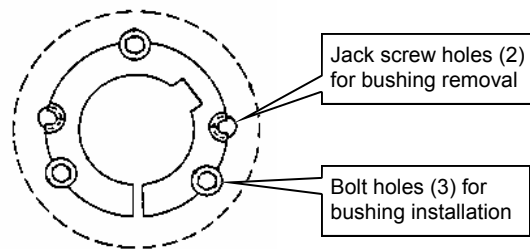



Replacement of wear parts

Fig. 83: Breaker assembly removal and installation

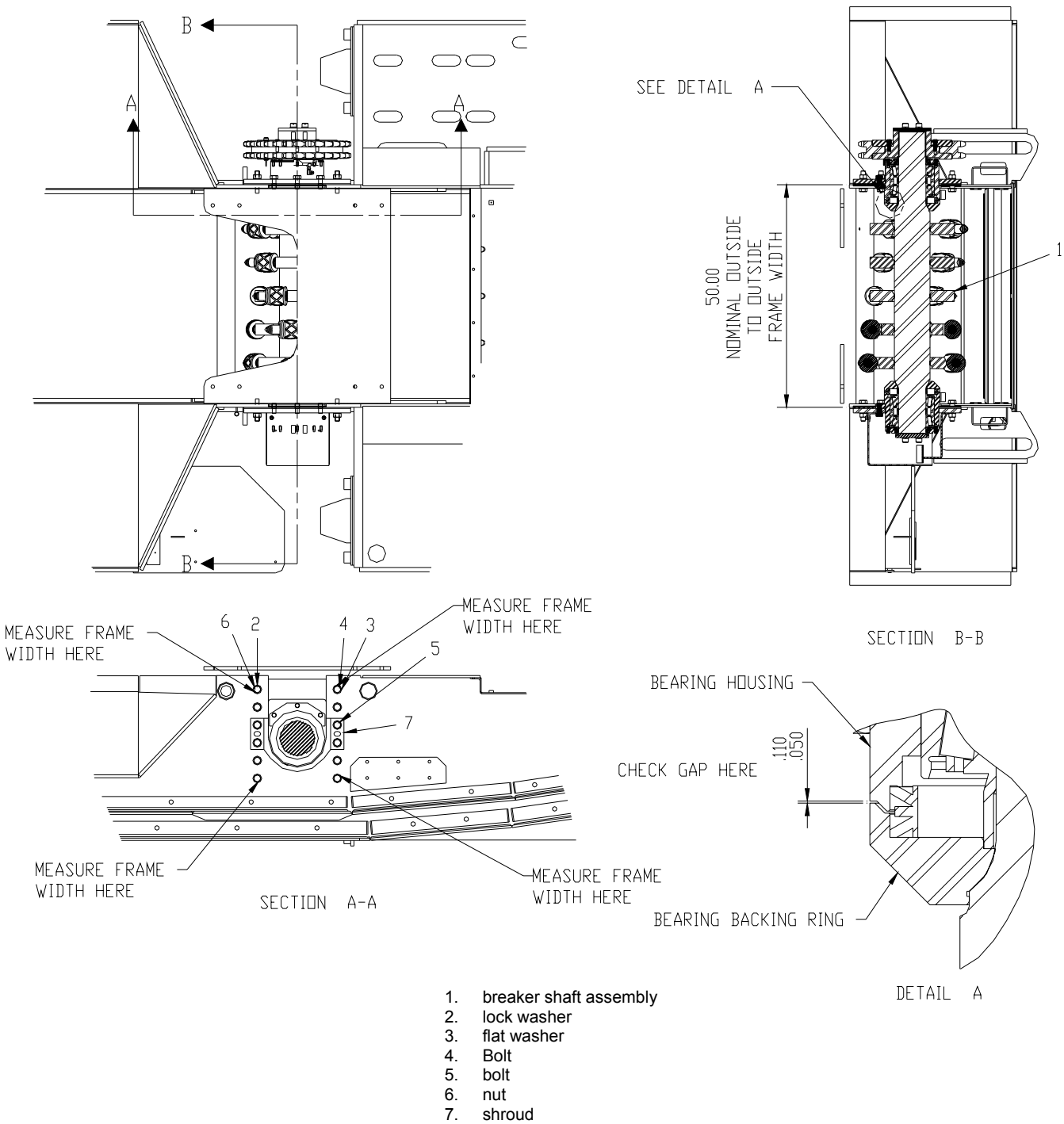

© DBT AMERICA 2007

- 1. breaker shaft assembly
- 2. lock washer
- 3. flat washer
- 4. Bolt
- 5. bolt
- 6. nut
- 7. shroud



Replacement of wear parts

Fig. 87: Remote power unit disassembly and assembly

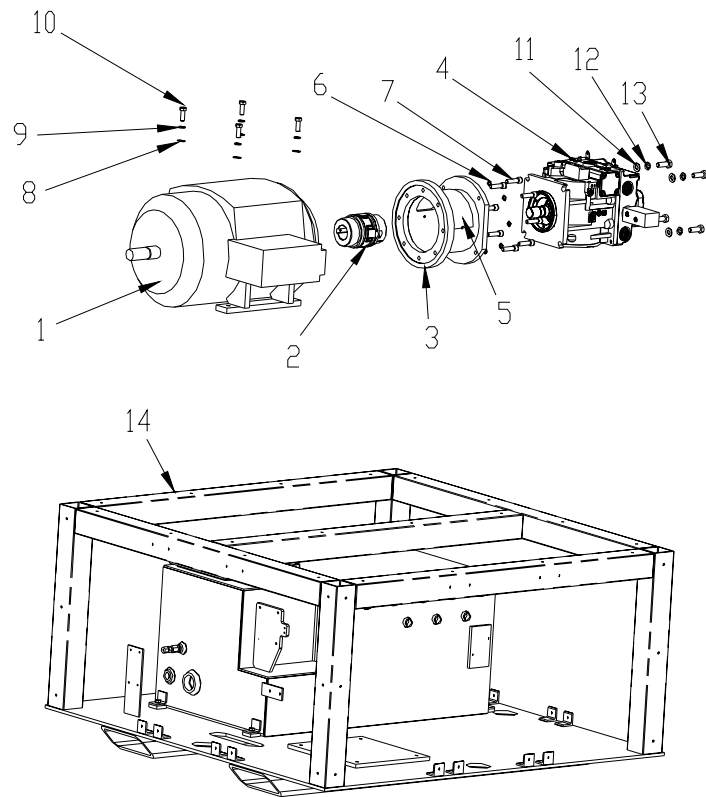

- | | |
|--------------------------|-----------------|
| 1. motor | 8. flat washer |
| 2. rotex coupling | 9. lock washer |
| 3. connecting tube | 10. bolt |
| 4. hydrostatic pump | 11. flat washer |
| 5. connecting tube cover | 12. lock washer |
| 6. lock washer | 13. bolt |
| 7. bolt | |



Tightening torques

Table 6: FSR hex bolts (SAE 5 and 325 steel)

Nominal diameter	Recommended torque setting
1/4"	9 ft-lbs
5/16"	18 ft-lbs
3/8"	31 ft-lbs
7/16"	50 ft-lbs
1/2"	75 ft-lbs
9/16"	110 ft-lbs
5/8"	150 ft-lbs
3/4"	250 ft-lbs
7/8"	378 ft-lbs
1"	583 ft-lbs
1 1/8"	782 ft-lbs
1 1/4"	1,097 ft-lbs
1 3/8"	1,461 ft-lbs
1 1/2"	1,748 ft-lbs
1 3/4"	3,114 ft-lbs
2"	4,504 ft-lbs
2 1/4"	6,497 ft-lbs
2 1/2"	7,144 ft-lbs
2 3/4"	12,092 ft-lbs
3"	15,744 ft-lbs

Table 7: FSR hex bolts (SAE 5 and 325 steel)

Nominal diameter	Recommended torque setting
#6	26 in-lbs
#8	52 in-lbs
#10	6 ft-lbs
1/4"	14 ft-lbs
5/16"	30 ft-lbs
3/8"	50 ft-lbs
7/16"	81 ft-lbs
1/2"	121 ft-lbs
5/8"	240 ft-lbs
3/4"	395 ft-lbs
7/8"	629 ft-lbs
1"	964 ft-lbs
1 1/8"	1,523 ft-lbs
1 1/4"	2,121 ft-lbs
1 3/8"	2,843 ft-lbs
1 1/2"	3,402 ft-lbs

CLICK HERE TO **DOWNLOAD** THE COMPLETE MANUAL

- Thank you very much for reading the preview of the manual.
- You can download the complete manual from: www.heydownloads.com by clicking the link below



- Please note: If there is no response to CLICKING the link, please download this PDF first and then click on it.

CLICK HERE TO **DOWNLOAD** THE COMPLETE MANUAL