

AAA-M97C3E01-006
(93115-00092)



95ZIV-3

AAA-M97C3E01-006 (93115-00092)



OPERATION & MAINTENANCE MANUAL

WHEEL LOADER

95ZIV-3

WITH CUMMINS N14-C ENGINE

SERIAL NUMBERS

97C3-1001 and up.

97C3-9001 and up.

NOTICE

READ AND UNDERSTAND THIS MANUAL
BEFORE OPERATING AND SAVE THIS
MANUAL ON THE MACHINE

CLICK HERE TO **DOWNLOAD** THE COMPLETE MANUAL

- Thank you very much for reading the preview of the manual.
- You can download the complete manual from: www.heydownloads.com by clicking the link below



- Please note: If there is no response to CLICKING the link, please download this PDF first and then click on it.

CLICK HERE TO **DOWNLOAD** THE COMPLETE MANUAL

SAFETY

Operate the machine slowly over rough ground and on a grade.

Do not operate on any grade that may be unstable (loose material, soft material, snow, or ice).

The range of temperature the machine is to be operated is between $-35^{\circ}\text{C} \sim 45^{\circ}\text{C}$.

When working on a grade:

- Turn "OFF" the transmission cut-off selector switch.
- Keep the attachment low.
- Keep the attachment facing up the grade as often as possible.
- Drive directly up or down the grade -- never across the grade.
- Stop when changing direction on a grade to maintain stability.
- Never coast down a grade.
- Select the same low gear to go down the grade as was selected to climb the grade. This provides some engine braking.

Before crossing a bridge, make sure that the capacity of the bridge is greater than the weight of the machine and any load it may be carrying.

Check for enough clearance before entering a building, doorway, tunnel, under wires or other structures.

Do not expose the machine to flames.

SAFETY DURING NORMAL OPERATIONS:

Vision to the rear on any machine is limited. Always use special caution when backing up.

Know the machine limits and do not exceed them.

Using the machine for purposes other than specified in the Operation & Maintenance Manual may create hazards that are not mentioned in this manual.

Do not use the machine as a crane where the safety of the operator or other workers are involved.

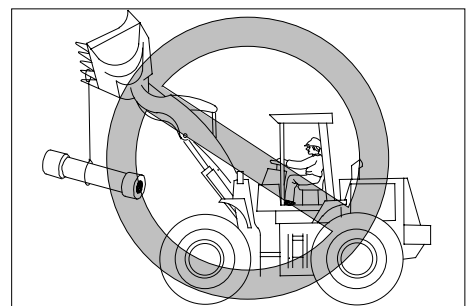
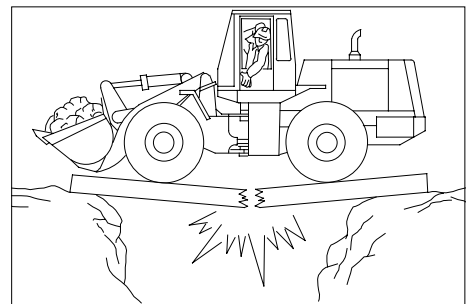

SAFETY

Safety Signs

All safety signs which are on the machine are shown here. Read them and understand them thoroughly. They contain information which is important for the safe operation and the safe maintenance. Follow the directions on the safety signs carefully.

It is very important that all safety signs be on the machine in the locations shown. If any sign is missing, damaged, or worn, get a replacement from your Kawasaki loader dealer and install it in the correct position.

NOTE: The sample safety signs in this section have part numbers to help you and your dealer obtain the correct replacement.

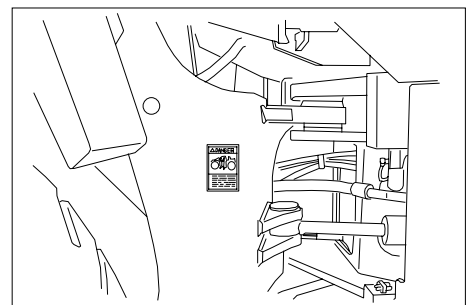
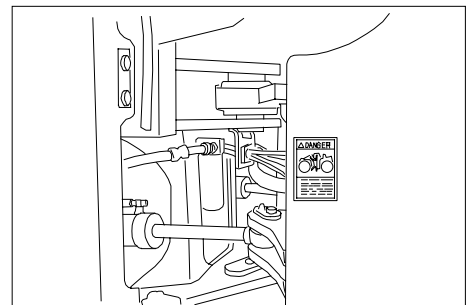
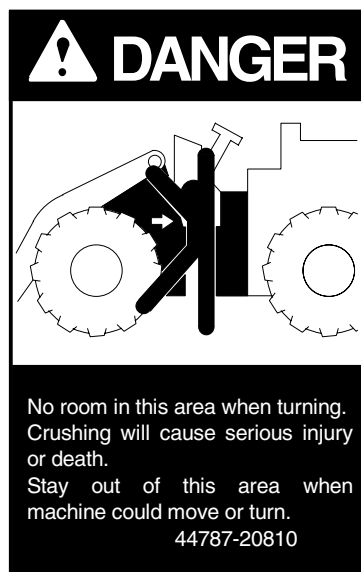

Emergency Steering (Option except Europe specification)

WARNING

Operation without normal steering could cause loss of control and injury or death.

If emergency steering lamp lights up, steer machine IMMEDIATELY to safe location and stop it.

Emergency steering works automatically when the steering hydraulic pressure goes down or the engine stops while the machine is operating.

When the steering hydraulic pressure goes down while the engine is running, the steering hydraulic warning lamp lights up.

Refer to "Steering Hydraulic Warning Lamp" page 45.

If the emergency steering works:

1. Keep the starter switch in the "ON" position even when the engine unexpectedly stops.
2. Immediately operate the steering wheel to bring the machine to a road shoulder or safe location.
3. Stop the machine. If necessary, use the emergency brake or lower the attachment to stop the machine.
4. Place wheel chocks in front of and behind the tires to prevent the machine from moving.
5. Contact your local Kawasaki loader dealer for necessary testing and repair.

ROPS (Roll Over Protective Structure) (Option except Europe specification)

WARNING

Operating with damaged or improperly mounted ROPS could cause serious injury or death. Be sure to observe the following.

- **Whenever seated, fasten the seat belt. (If equipped)**
- **Do not modify ROPS, such as drilling or welding.**
- **Do not use ROPS deformed.**
- **If any damage or loose bolts are found, do not operate until repaired.**
- **Never repair or modify ROPS without manufacturer's approval and instructions.**

5. Rear Working Light Switch

Rear working light switch is used for turning on and off the rear working lights.

Turn off the rear working lights when roading to prevent blinding the driver behind you.

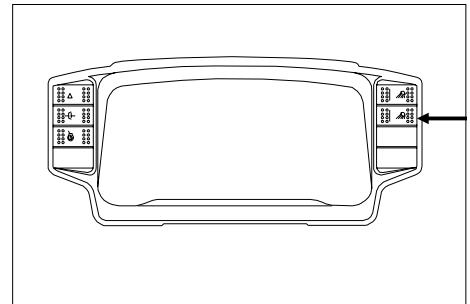

6. Transmission Cut-Off Selector Switch

Transmission cut-off selector switch is used to change the function of the brake pedals.

Normally this switch should be "ON".

"OFF" ---When the brake pedals is depressed, only the service brakes are engaged keeping the transmission directional clutch engaged. (brake only)

"ON" -----When the brake pedals is depressed, the service brakes are engaged and the transmission directional clutch is disengaged (brake and declutch).

Refer to "Brake Pedals" page 32 for the function of the left brake pedal.

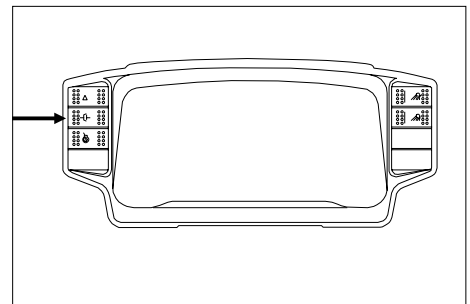

CAUTION

Transmission cut-off feature momentarily places transmission in neutral which may allow machine to roll when on a grade.

Do not turn transmission cut-off selector switch to "ON" when operating on a grade.

7. Cold Start (ether injection) Switch

Cold Start Switch is used for easy engine starting in cold weather. Ether is injected into the engine after turning this switch to "ON" and "OFF".

Refer to "Cold Start" page 63 for proper use.

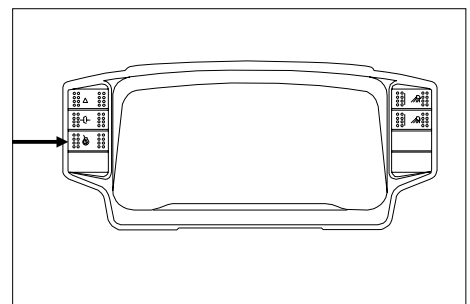

OPERATOR'S AREA

Seat

Seat Adjustment

Adjust the seat for comfort and so that the pedals may be pushed fully down when the operator's back is fully back.

⚠ WARNING

Unexpected movement of seat could result in death or serious injury.

Stop machine before adjusting seat position.

Reclining

Rotate control handle (1) forward and hold, select backrest angle, release control handle.

Forward / Backward

Lift lever (2) up and hold, slide seat to desired position, release handle.

Suspension

Rotate handwheel (3) until your body weight is selected on indicator for maximum suspension performance. If the seat suspension is set below your body weight, excessive bouncing will occur. This will result in premature seat suspension wear and/or failure.

Seat Height

Lift front handle (4) or rear handle (5) up and hold to release lock for spring loaded seat. Adjust to desired position by adding or removing your body weight to front or rear of seat cushion. Release handles to lock.

Armrests

- Rotate control knob (6) to select desired angle. Pivot up and parallel with backrest when not in use.

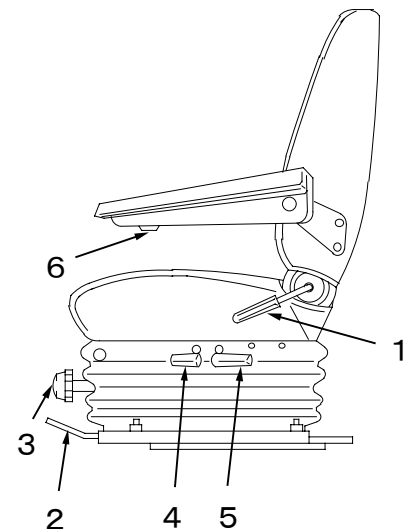

Seat Belt (Option except Europe specification)

⚠ WARNING

Improper use or maintenance of seat belt could result in death or serious injury.

- **Inspect seat belt and mounting hardware before operating machine and replace any defective components.**
- **Always fasten seat belt when operating machine.**
- **Properly adjust seat belt at beginning of each shift or when operator changes.**

OPERATION

1. Lower the attachment to the ground.
2. Stop the engine.
3. Check the oil level gauge on the side of the hydraulic oil tank.
4. The oil level is OK if the oil reaches the middle of the level gauge.
5. If needed, add the required amount of the oil.
Refer to "Recommended Lubricants" page 139 for the suitable viscosity of the oil according to the ambient temperature.

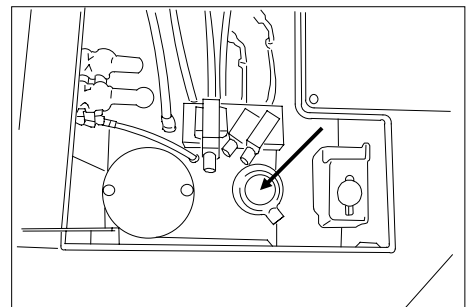
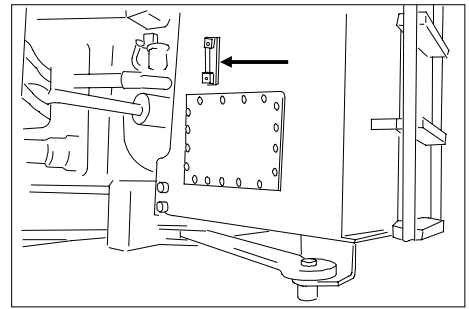

D. Check Engine Coolant Level

⚠ CAUTION

Pressurized radiator tank is used for this machine.

Spray of hot coolant could cause burns.

Stop engine and allow radiator and coolant to cool completely, then open cap slowly to relieve pressure.

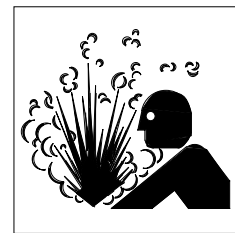

⚠ CAUTION

Cooling system conditioner contains alkali that could caustic burns or blindness.

Avoid contact with skin and eyes to prevent injury.

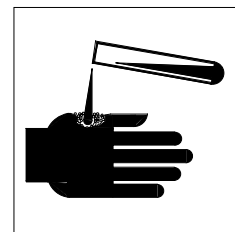

1. Stop the engine and allow the radiator and coolant to cool completely.
2. Push the button (1) on the cap (2) of the radiator tank and slowly open the cap (2).
3. Check the coolant level.
4. Coolant level is normal if coolant is to the lower part of neck pipe.
5. If needed, add the required amount of the coolant.
Refer to "Coolant Specification" page 140 for the correct mixture.

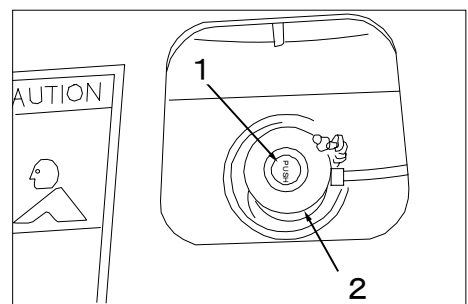

OPERATION

1. Park the machine on a level ground, apply the parking brake, and lower the attachment to the ground.
2. Check the oil level with engine at low idle.
3. At low oil temperature, use the side of dipstick marked "COLD". Normal oil level is within shaded area as shown.
4. At high oil temperature, use the side of dipstick marked "HOT". Normal oil level is within shaded area as shown.
5. If the oil level is lower than the specified, add recommended oil while the engine is at idle. Do not overfill. Refer to "Recommended Lubricants" page 139.

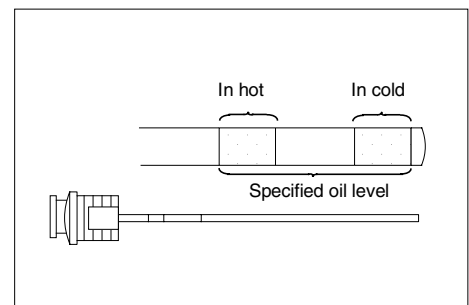
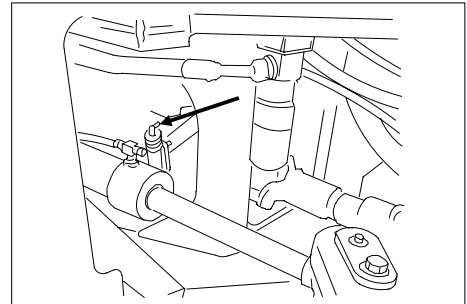

WARNING

With articulation stopper in "LOCKED" position, machine will not steer which, while operating, could cause an accident result in death or serious injury.

Return articulation stopper to "STORED" position after checking transmission oil level.

IMPORTANT

Never mix CD engine oil and auto transmission fluid. Either may be used in transmission but they must not be mixed.

Determine what type of oil is in transmission and use only that type.

D. Check Service Brake Operation

1. Firmly depress the right hand brake pedal.
2. Release the parking brake.
3. Select the transmission shift lever 2nd and REVERSE.
4. Slowly accelerate the engine to full speed.
5. The machine should not move.

OPERATION

3. Lower the bucket parallel to the ground or dump it slightly forward.

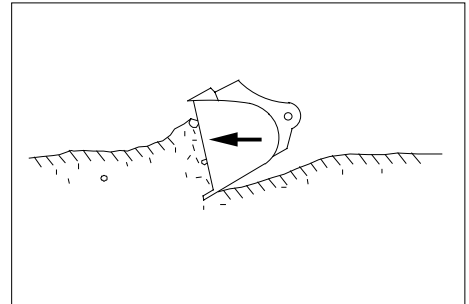

4. Run the machine slowly in 1st or 2nd speed.
Increase engine speed as the bucket digs deeper.
5. When the bucket is filled, move the bucket control lever to the "Roll Back" position.

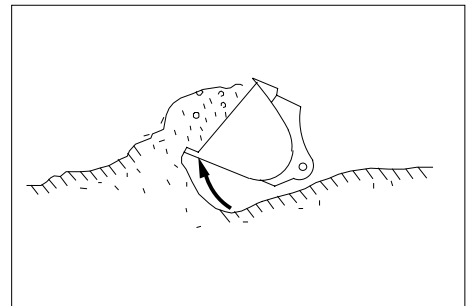

6. Move the boom control lever to the "Raise" position to clear the ground.

Dozing

IMPORTANT
Dozing or pushing with dumped bucket or attachment may cause severe damage to linkages.
Keep bucket or attachment bottom parallel to ground.

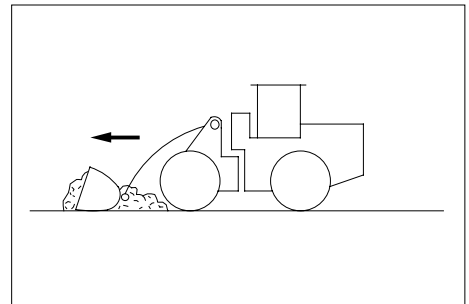

Ground Levelling

1. Keep the loaded bucket slightly above the ground.
2. While running the machine backward, dump the bucket little by little to evenly spread material on the ground.

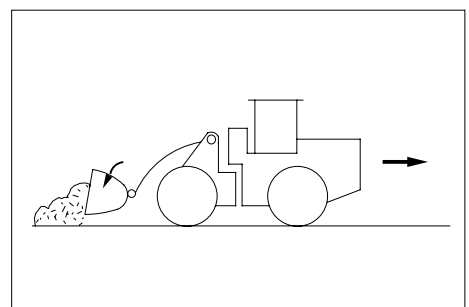

SPECIAL PROCEDURES

Towing

WARNING

Improper towing could result in death or serious injury.

Follow safety warnings found under "Safe Operation -- Special Operating Conditions" page 8.

This machine is equipped with a hitch on the rear end for towing a troubled machine.

1. Inspect the cable for damage. Never use a damaged cable.
2. Pull the handle to open the radiator grill.
3. Connect the cable to the drawbar. Make sure the drawbar and split pin are in the original position.
4. Close the radiator grill.
5. Connect the other end of the cable to the troubled machine.
6. If the service brake on the towed machine does not work; do not allow an operator on the towed machine, and attach another vehicle of adequate size to the rear to act as a braking vehicle.
7. Keep personnel away from between the towing machine and the towed machine.
8. Tow the machine slowly with gradual and smooth movement.
9. Use flashing lights or other warning signals when towing.

If your machine must be towed, contact your nearest Kawasaki loader dealer for the necessary information or assistance.

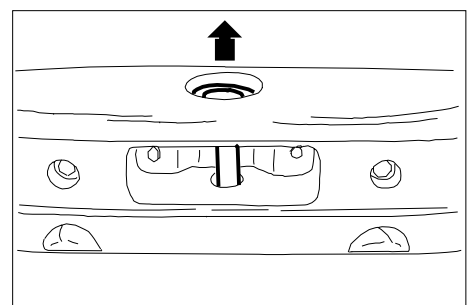
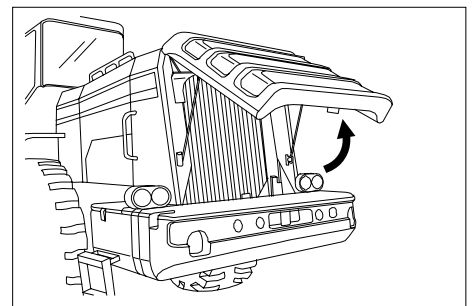
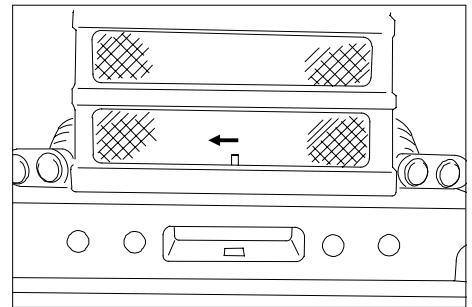

WHEN REQUIRED MAINTENANCE

B. Replace Cutting Edge (option)

1. Park the machine on a level ground and apply the parking brake.
2. Raise the bucket to a convenient height and put blocks under the bucket to prevent it from coming down.
3. Stop the engine.
4. Remove the cutting edge. Clean all contact surfaces (bottom of bucket, top of cutting edge).
5. If other side of the cutting edge is not worn, turn it around and install it so that the new side faces the front. If both sides are worn, install a new cutting edge.
6. Install all bolts and tighten them to $1314\text{N} \cdot \text{m}$ ($134\text{kgf} \cdot \text{m}$).
7. Retighten them after a few hours operation.

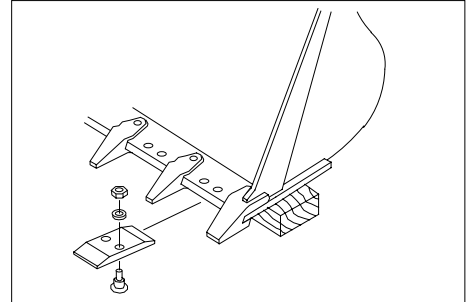

C. Check and/or Replace Seat Belt (Option except Europe specification)

1. Inspect the condition of the seat belt and all mounting hardware frequently.
2. Replace the seat belt or any part of the mounting hardware if it is damaged.
3. Replace the seat belt every three years regardless of its condition or appearance.

C. Check Battery Electrolyte Level

⚠ WARNING

Batteries produce explosive gases which could cause burns or blindness.

- Ventilate area to remove explosive gases.
- Wear eye or face protection when working on or around batteries.
- Keep flames and sparks away from batteries.

⚠ WARNING

If the battery is being used with insufficient battery electrolyte level, the deterioration on the parts in the case could be in the advanced stage.

It could cause to shorten the battery life or to emit sparks from the deterioration parts in the case, as a result the battery case could explode.

Keep the battery electrolyte level in the proper level.

⚠ WARNING

Batteries contain lead, and acid which may cause burns.

Avoid contact with skin or clothing and wear hand, eye, and face protection when working on or around batteries.

If lead, or acid contacts skin or clothing, immediately wash with water.

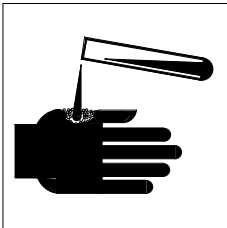
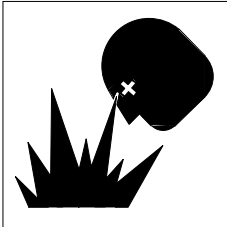

1. Park the machine on a level ground, apply the parking brake, lower the attachment to the ground, and stop the engine.
2. Clean the battery surface with a clean cloth or soft brush.
3. Check the battery electrolyte level in each cell. Electrolyte should cover the cell plates.
4. If the level is low, add distilled water until it reaches the bottom of the filler neck.

NOTE: If a maintenance free battery is used, step 3 and 4 of this inspection and maintenance is not required.

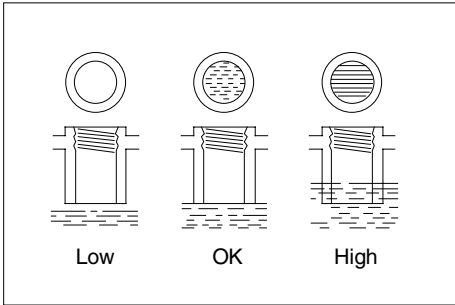
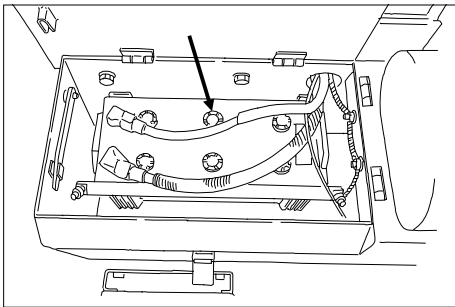

EVERY 250Hrs MAINTENANCE

IMPORTANT

Severe engine damage may result from running with unfiltered air.

Do not operate engine if any leaks or defects are found on air intake system.

J. Check Differential Gear Oil

1. Park the machine on a level ground, apply the parking brake, lower the attachment to the ground, and stop the engine.
2. Remove the oil level plug from the front axle housing, using a 12mm hex (Allen) wrench.
3. If the oil level is lower than the plug, add the specified oil through the level plug hole.
Refer to "Recommended Lubricants" page 139.
4. If there is any sign of water in the oil, drain and replace the oil. Oil containing water looks milky.
5. Retighten the level plug.
6. Check the rear axle oil level following the same steps.

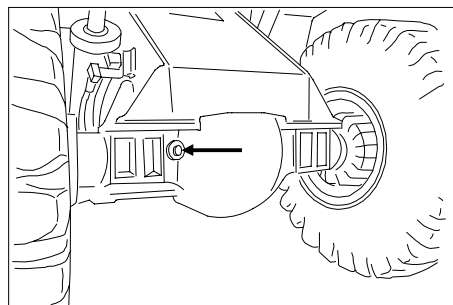

Front Axle

K. Check Planetary Gear Oil

1. Check the oil level on all four wheels.
2. Move the machine on a level ground so that "TOP" mark (1) on the planetary gear housing comes top.
3. Turn "ON" the parking brake switch, lower the attachment to the ground, and stop the engine.
4. Remove the oil level plug (2) on the housing, using a 12mm hex (Allen) wrench.

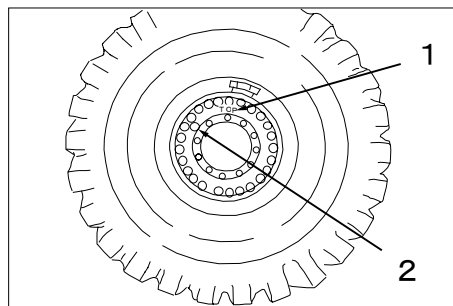

E. Adjust Parking Brake Lining

WARNING

When parking brake is released for adjusting brake lining, machine could move unexpectedly causing serious injury or death.

Make sure to lower attachment to ground, and put chocks under wheels.

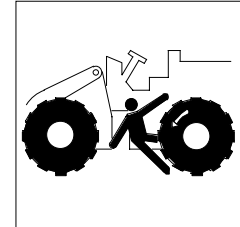

1. Park the machine in a safe place on firm level ground and steer it fully to one side for easier access.
2. Lower the attachment to the ground and turn "OFF" the parking brake switch.
3. Align the inspection hole (1) with the adjuster wheel by turning the hole 8° counterclockwise from the bottom. Do not enter the articulation area or under the machine.
4. Place wheel chocks in front of and behind the tires to prevent the machine from moving.
5. Place a "DO NOT OPERATE" tag on the steering wheel.
6. Remove a cap of the inspection hole (1) on the brake drum.
7. Turn the adjuster wheel fully upward to close the clearance between the brake drum and the brake lining (shoe). The adjuster wheel can be reached through the inspection hole.
8. Return the adjuster wheel eight clicks downward. (Now the clearance is 0.23mm)
9. Check parking brake operation as described on page 67.

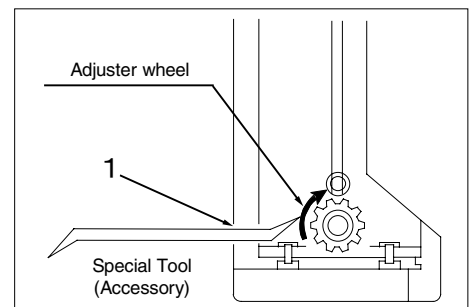
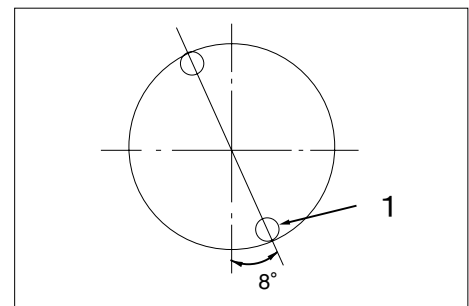
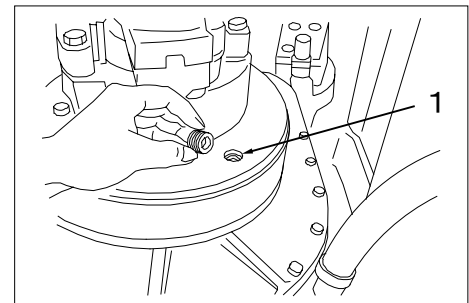

NOTE: If the brake drum has been excessively hot (ie. burnt paint) or the parking brake will not adjust, contact your Kawasaki loader dealer.

EVERY 2000Hrs MAINTENANCE

G. Overhaul Auto-adjuster Valve

- Contact your Kawasaki loader dealer.

H. Check Service Brake Disk Wear

- Contact your Kawasaki loader dealer or local Cummins engine dealer.

I. Check and Adjust Valve Lash Clearance



- Contact your Kawasaki loader dealer or local Cummins engine dealer.

J. Replace Air Conditioner Filter Elements(option) Outer filter replacement

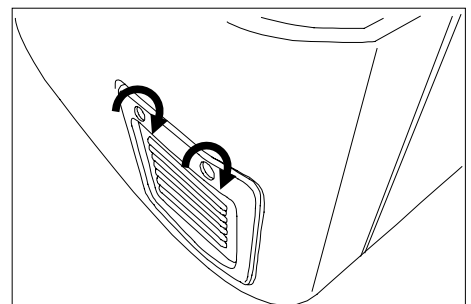
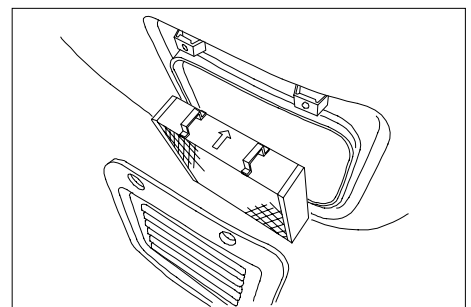
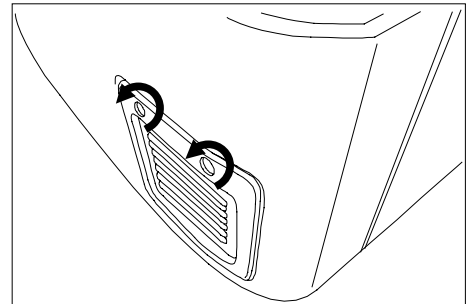
1. Park the machine on a level ground, apply the parking brake and lower the attachment to the ground.
2. Turn the air conditioner "OFF" and stop the engine.
3. The cover for the outer filter is located at the right rear side of the cab.
Turn the rings counterclockwise and then remove the cover.
4. Remove the outer filter from the cab, and replace it with new one.
When installing the outer filter into the cab, be sure to align the air flow arrow on the outer filter to point toward the cab.
5. Install the cover to the cab and turn the rings clockwise to fix the cover.

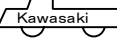

TROUBLESHOOTING

PROBLEM	POSSIBLE CAUSES	SOLUTIONS	PAGE
Low power	Service or parking brake dragging	Inspect and correct Refill oil / Repair leak Clean or replace strainer 	65
	Low oil level in transmission Suction strainer in transmission clogging Clutch oil pressure too low Torque converter oil pressure too low Transmission clutch failure		122
Oil leakage from transmission	Air breather clogged Seal damage (between engine and torque converter housing)	Clean and refill with oil 	123
Torque converter overheat	Oil level too low	Add oil / Repair leak	65
	Dozing, continuous pushing application Operating in too high a speed range Long downhill driving	Reduce load Use lower gear Change application	70
	Radiator clogged: coolant temp also high Defective alarm switch (gauge is in green) Torque converter / Transmission failure Oil pressure too low	Clean radiator fins 	98

AIR CONDITIONER (option)

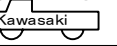
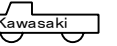
PROBLEM	POSSIBLE CAUSES	SOLUTIONS	PAGE
Low cooling when A/C "ON"	Hot water continues to flow through heater core	Shut off valve in heater hose line at block	50 99 118 117
	A/C not set for maximum cooling	Adjust controls/vents	
	Condensor fins plugged	Clean	
	A/C filters plugged	Clean or replace	
	A/C compressor belts slipping/broken	Adjust/Replace	
Low heater out put	A/C refrigerant charge low		50
	Engine not warmed up	Warm up engine	
	No hot water flow to heater core	Open shut off valve on block	
	Air conditioner running	Turn A/C off	
	Heater vents not adjusted properly	Adjust controls/vents	
Defective heater motor or switch			

OUTLINE	00-1
CHASSIS GROUP	12-1
POWER GROUP	22-1
TORQUE CONVERTER AND	
TRANSMISSION GROUP	32-1
HYDRAULIC GROUP	42-1
BRAKE GROUP	52-1
ELECTRICAL GROUP	62-1
OPERATOR STATION GROUP	72-1

Liquid Gasket and Screw Lock Agent

To reassemble the disassembled parts, be sure to use the specified liquid gasket or screw lock agent or the equivalent according to the following lists:

Liquid Gasket

Code	Manufacturer	Product name
AA01	Loctite	Plastic Gasket 568
AA02	Loctite	Hydraulic sealant
AA03	Three Bond	Three Bond 1215

Screw Lock Agent

Code	Manufacturer	Product name
AB01	Loctite	(High strength) Loctite 262
AB02	Three Bond	(Medium strength) Three Bond 1327
AB03	Three Bond	(Low strength) Three Bond 1374

Cautions regarding parts removal

If a screw or shaft to be removed has been locked by one of the above agents, remove the screw or shaft using a general tool, such as a wrench or puller.

If it is difficult to remove the screw or shaft, heat the bolt to soften the agent (200 to 250 °C) using a soldering iron or gas torch.

Caution: If there is a seal near the screw or shaft to be removed, carefully use the heating method for removal, to avoid damage to the seal.

If heat has been used to remove the bolt a new bolt should be used during reassembly.

Cautions regarding reassembly

To reassembly a screw:

Completely remove the hardened lock agent from the screw and the threaded hole before reassembling the screw.

Note: A piece of hardened lock agent may be peeled off and remain in the component. The remaining piece may cause malfunction during operation.

To bond a plane or to fit a shaft:

Remove the hardened lock agent using a wire brush or the like, and polish the surface using sand paper.

Use of a Loctite primer like Locquic R Primer T cleans threads and speeds curing time.

Antiseize Agent

Code	Manufacturer	Product name
AC 01	Loctite	Loctite 767 (Paste or spray)

Center Pin

Adjusting Shim(#5)

The clearance between the front chassis and bearing cover (#3) is $0.75 \pm 0.5\text{mm}$ before shim adjustment. Add shims so that the clearance is $0.1 \pm 0.05\text{mm}$.

- ⊗ N-m (kgf-m)
- #8 461N-m (47.0 kgf-m)
- #9 421N-m (43.0 kgf-m)

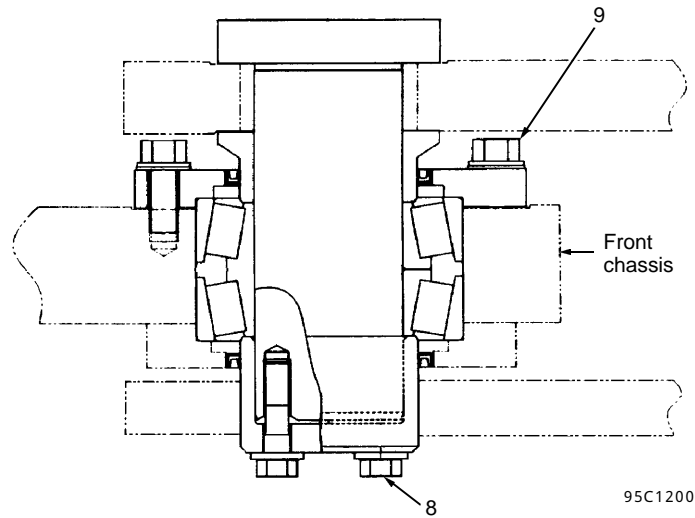

95C12002

Installing bearing cover

Install the bearing cover so that the grease nipple mounting hole is positioned at the specified angle as shown in the right figure.

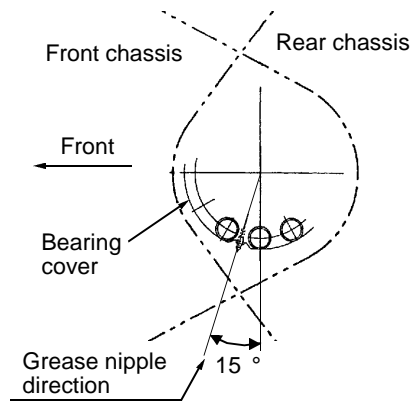

95C12003

Installing bearing outer ring(#3)

Install the bearing outer ring so that the split is perpendicular to the front-rear line of the machine.

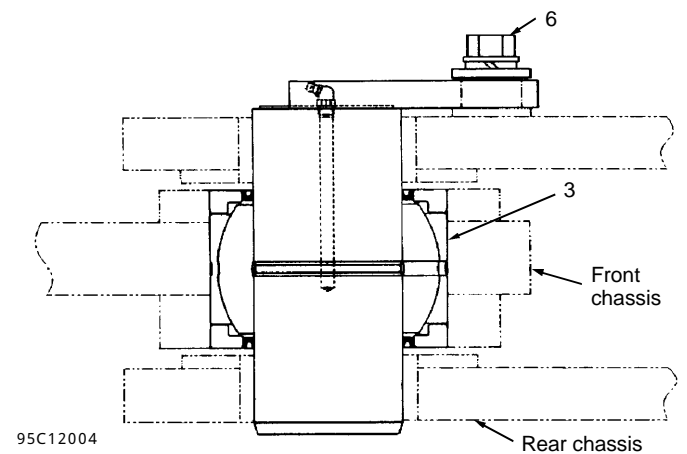

95C12004

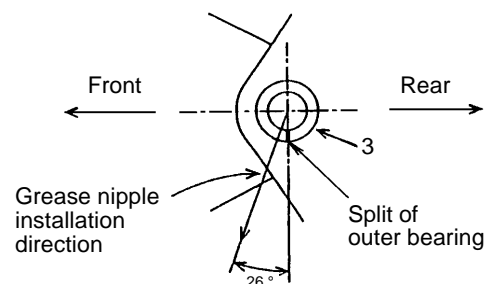

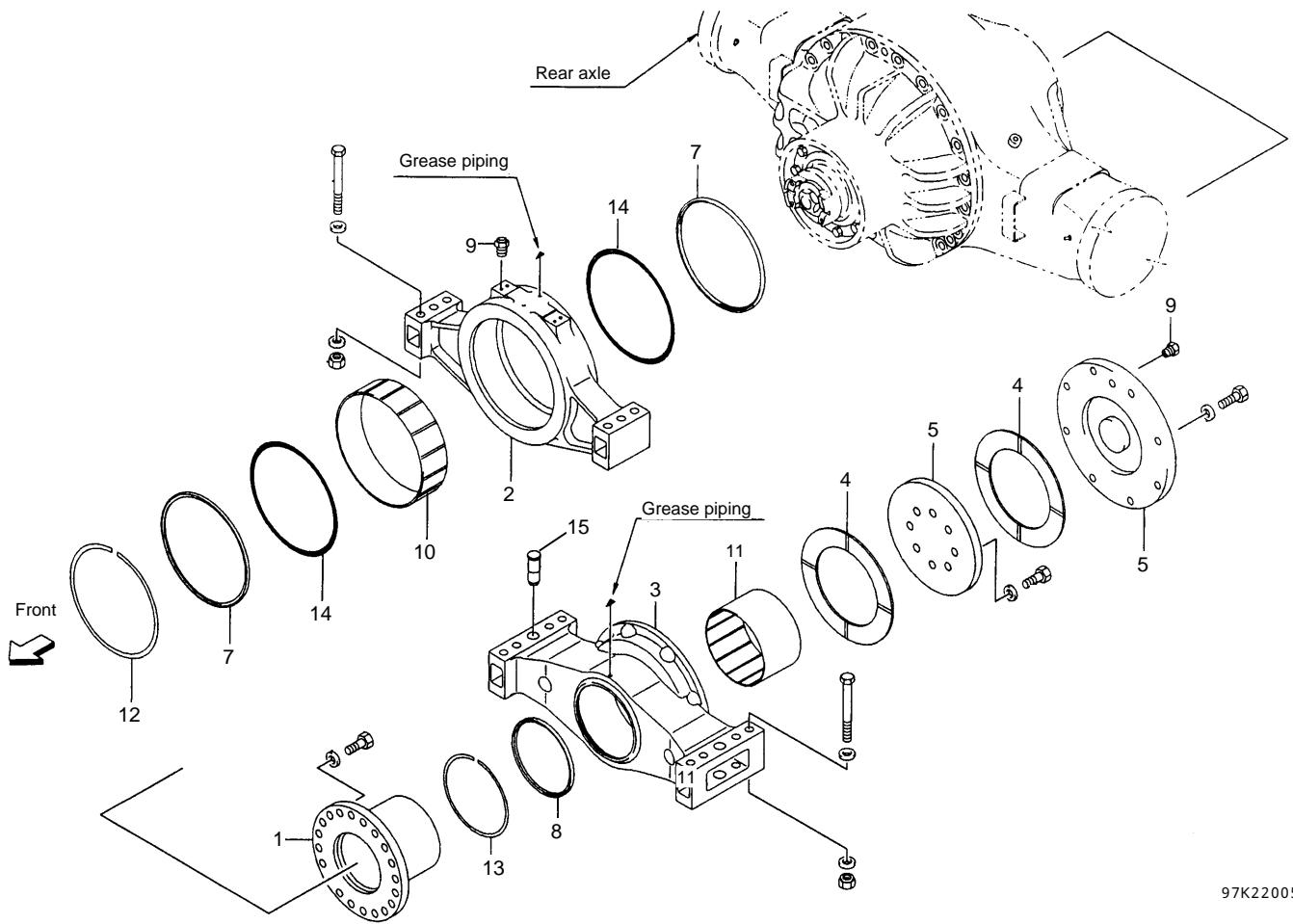

97K22005

- | | | |
|------------------------------|---------------|---------------|
| 1. Shaft | 7. Packing | 13. Snap ring |
| 2. Rear axle support (front) | 8. Packing | 14. O-ring |
| 3. Rear axle support (rear) | 9. Breather | 15. Dowel pin |
| 4. Wear ring | 10. Bushing | |
| 5. Plate | 11. Bushing | |
| 6. Plate | 12. Snap ring | |

Transmission

Outline of Transmission Operation

The transmission is equipped with six clutches: Forward low range, forward high range, reverse, and 1st, 2nd and 3rd speeds. Combining the clutches as shown in the table here provides four forward speeds, and three reverse speeds for a total of seven speeds. Two clutches must be engaged at the same time to move the machine.

Clutch Speed range	Clutch					
	L	H	R	1	2	3
F 1						
F 2						
F 3						
F 4						
N				○	○	○
R 1						
R 2						
R 3						

(Either 1st or 2nd or 3rd)

Gear reduction is by the planetary gear method. As shown, each reduction gear set consists of a sun gear at the center, three (four) planetary gears located around it, a ring gear around them, and a carrier (frame) supporting the planetary gears. The speed is changed by fixing or releasing the ring gear or the carrier.

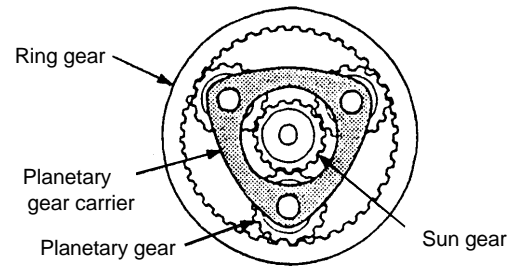

97ZA32.04

Automatic or manual speed change is available depending on the position of the shift lever, as shown in the table at the right.

Automatic speed change refers to one where the best speed range is determined by a computer according to the engine speed and the machine speed detected.

shift lever	Function
1	Held in 1st speed range for both forward and reverse.
2	Held in 2nd speed range for both forward and reverse.
3	Held in 3rd speed range for both forward and reverse.
A	Automatic speed change according to shift map (computer) for 2nd through 4th speeds forward and 2nd through 3rd speeds reverse.

Modulator Valve Unit

Construction

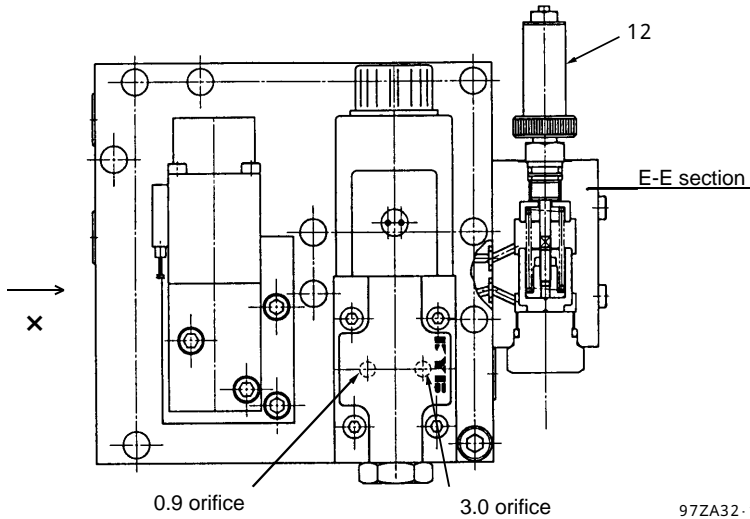

97ZA32-16

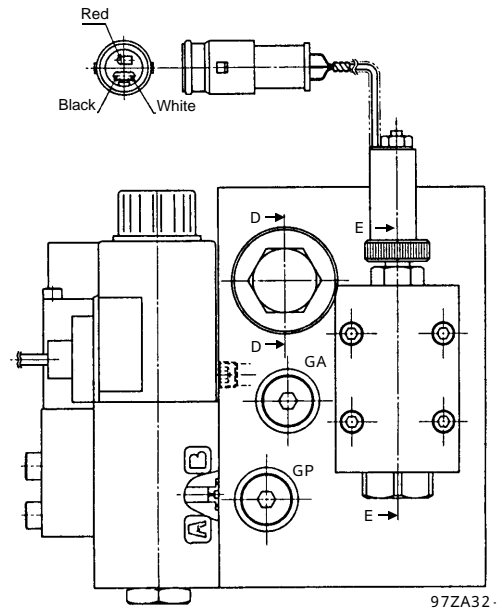

97ZA32-18

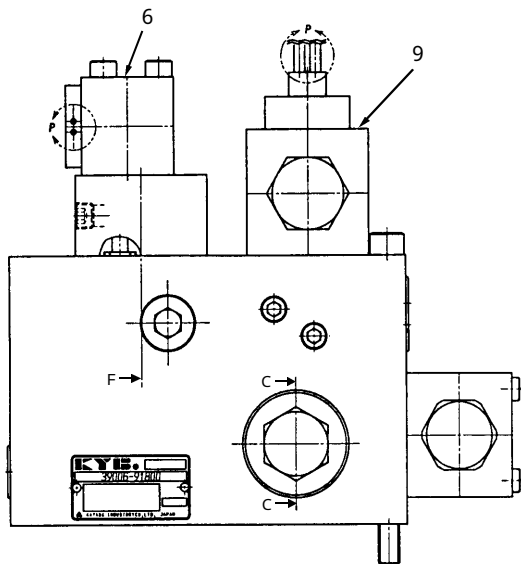

97ZA32-17

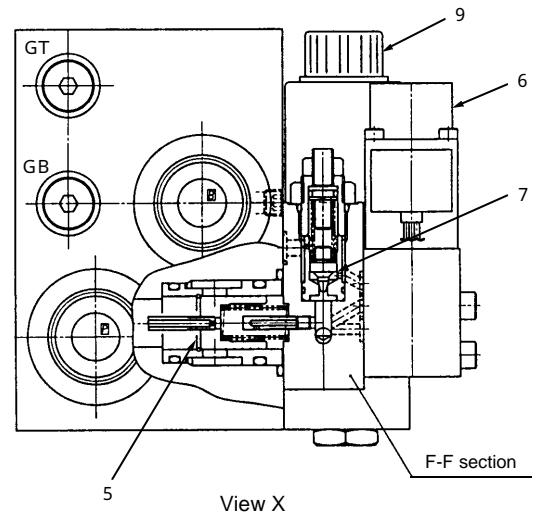

97ZA32-19

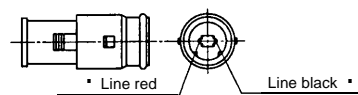

97ZA32-20

Connector for modulator valve (1) and (2)

- 5. Clutch pressure regulator valve
- 6. Modulator valve (1)
- 7. Relief valve (2.9MPa) (30kgf/cm²)
- 8. T/C inlet relief valve (0.9MPa) (9kgf/cm²)
- 9. Modulator valve (2) (Solenoid valve)
- 10. Check valve 1 (0.6MPa) (6kgf/cm²)
- 11. Check valve 2 (0.4MPa) (4kgf/cm²)
- 12. Pressure difference sensor

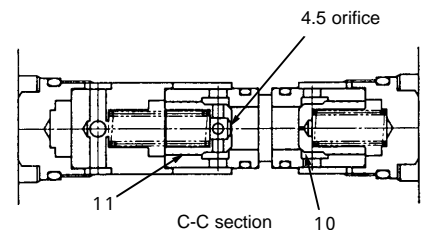

97ZA32-21

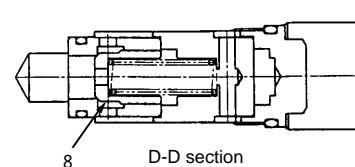

97ZA32-22

Loading/Steering Hydraulic System Diagram

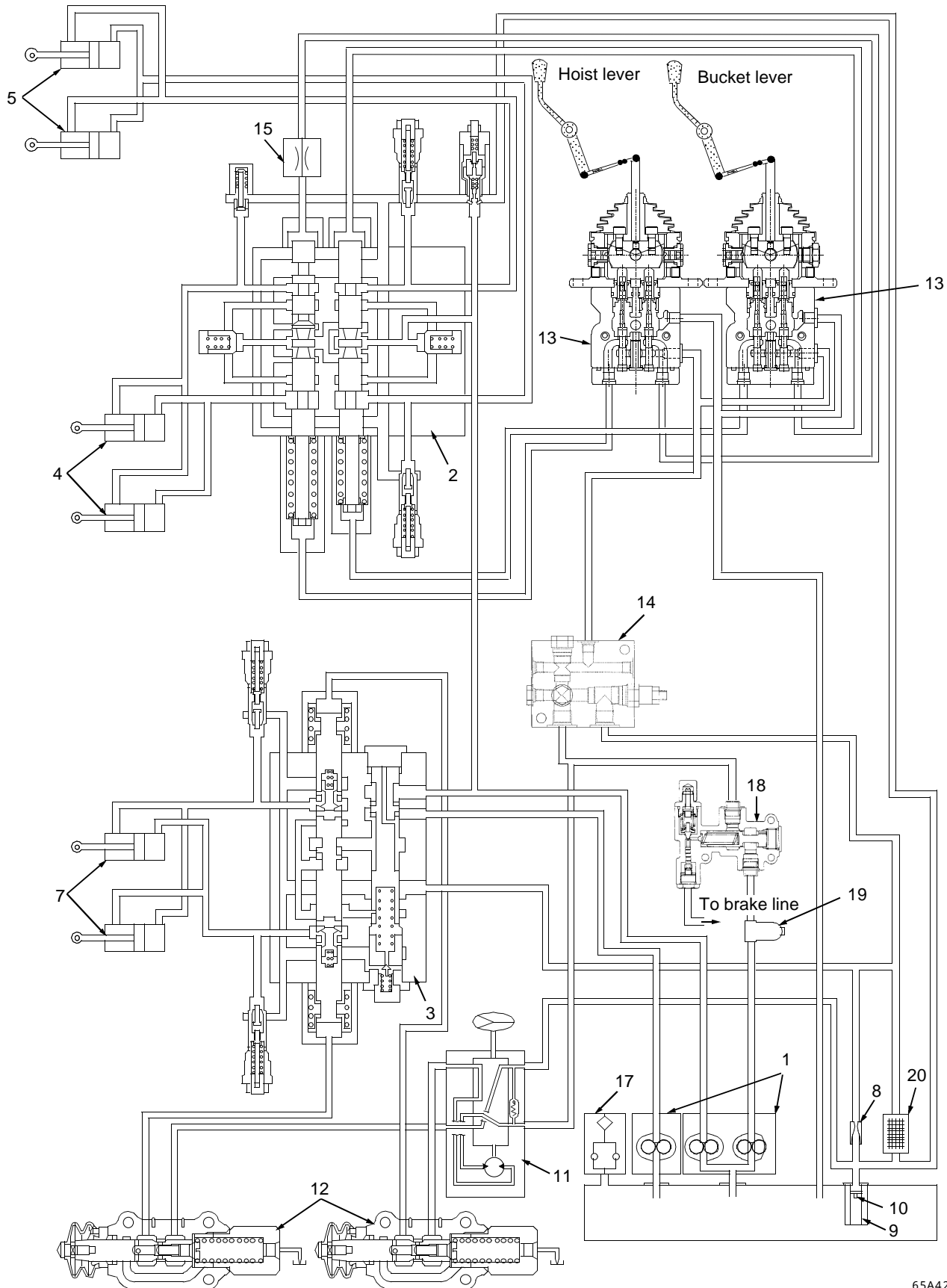

Hydraulic Pump

Double Pump

- 1. Oil seal
- 2. Oil seal
- 3. Pressure plate
- 4. Driven gear
- 5. Drive gear
- 6. Coupling

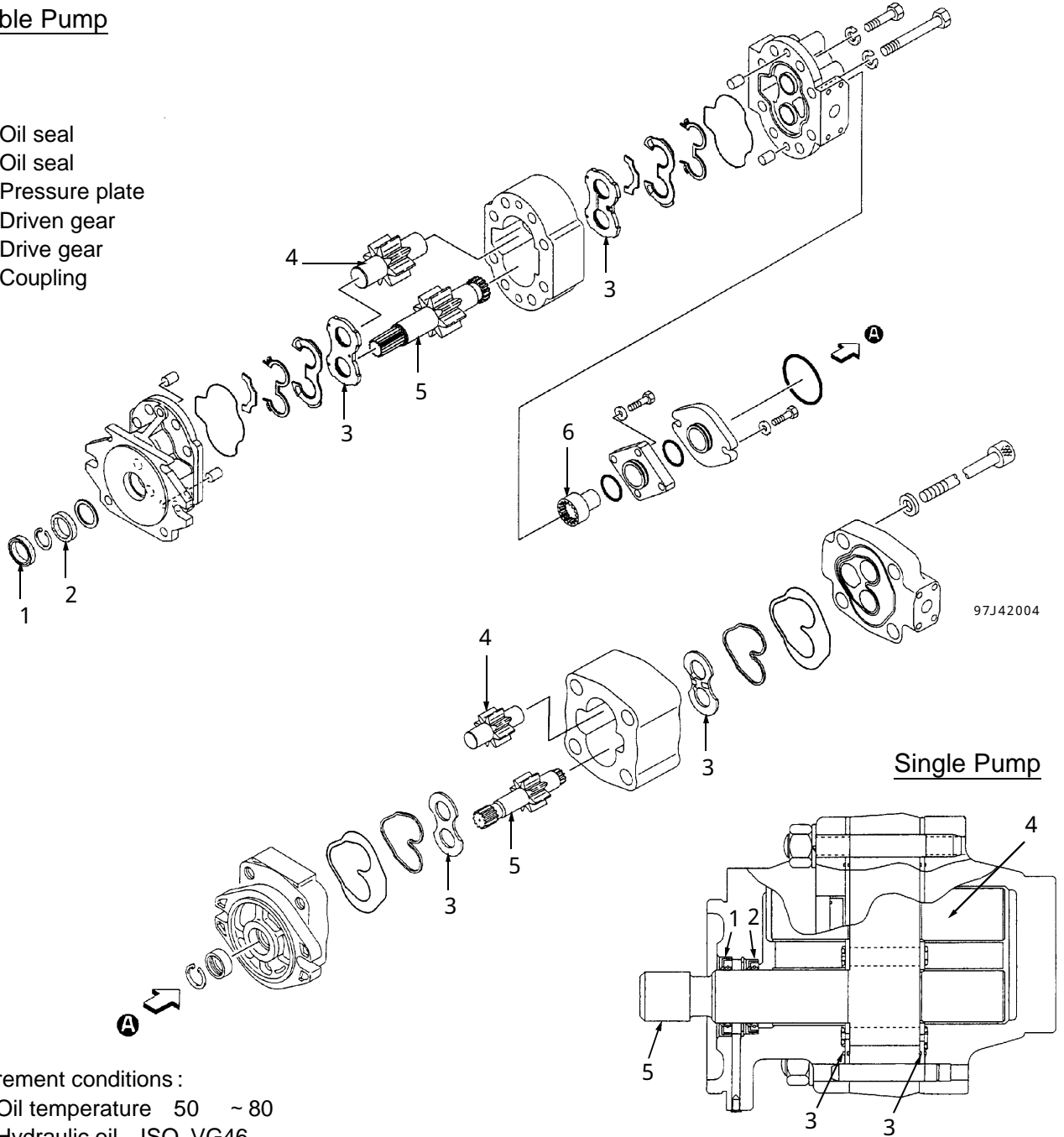

Measurement conditions :

Oil temperature 50 ~ 80

Hydraulic oil ISO VG46

	Double pump		Single pump
	Front	Rear	
Applicable circuit	Main circuit	Pilot-brake circuit	Steering, main & switch circuit
Theoretical discharge cm ³ /rev	91	36	113
Maximum operation pressure MPa (kgf/cm ²)	20.6 (210)	18.1 (185)	20.6 (210)
Maximum speed min ⁻¹	2,500	2,500	2,500

Pilot Relief Valve Unit

Construction

The relief valve unit consists of relief valve and check valve.

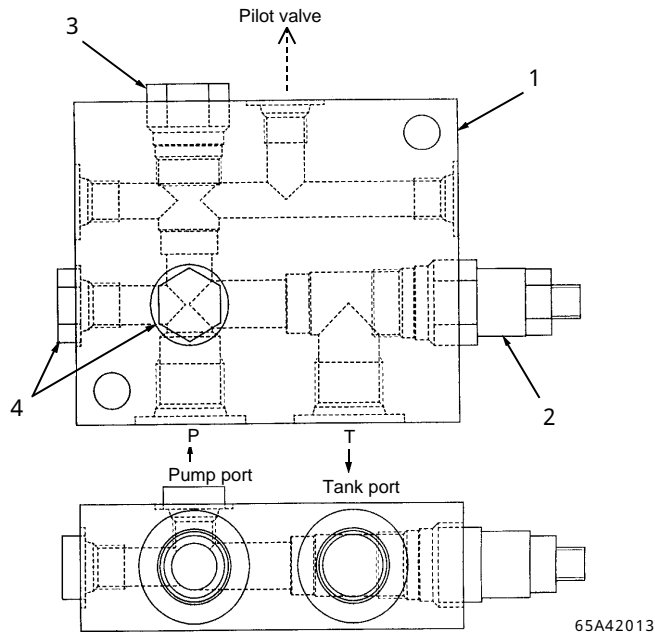

1. Relief valve unit
2. Relief valve
3. Check valve
4. Plug

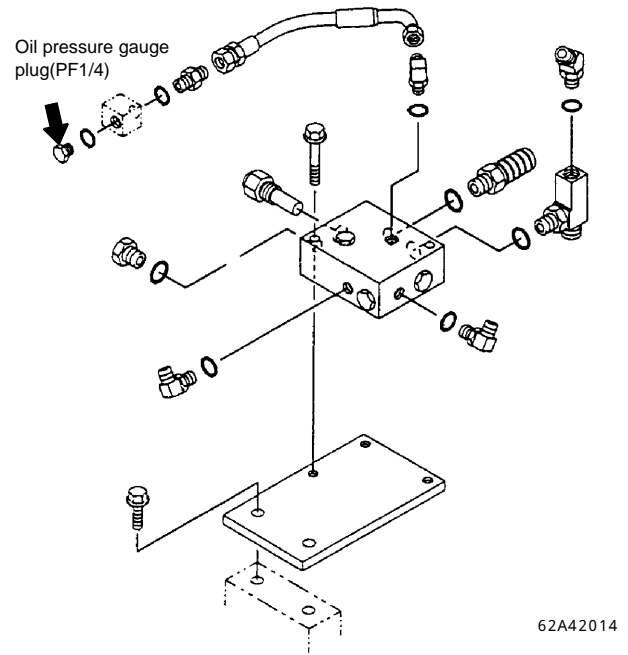

Oil press test port

- After removing the plug on the relief valve unit upper side, install the pressure gauge then check hydraulic oil pressure.
- Relief valve setting pressure $3.9 \pm 0.3\text{MPa}$ ($40 \pm 3 \text{kgf/cm}^2$).

Note

- 1) : Tightening torque
#2, #3 45 ~ 50N-m (4.59 ~ 5.10kgf-m)
- 2) Relief valve unit hexagon bolt •Width across flats
mm
22.4mm.

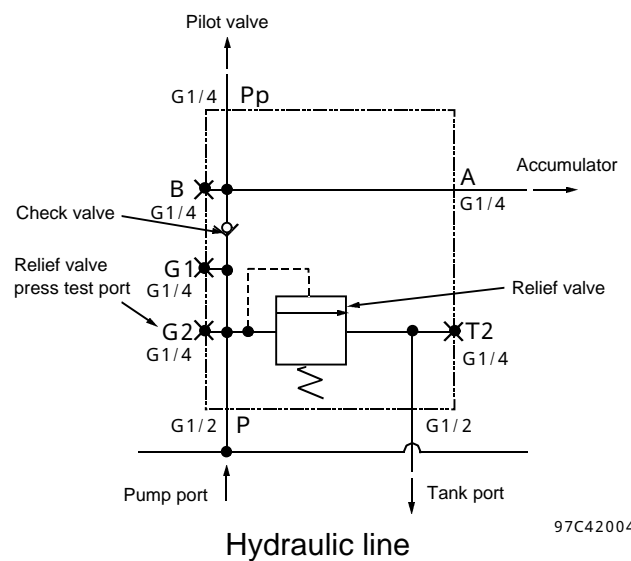

Hydraulic line

Make-up valve

(Installed on the rod side of the hoist cylinder line)

When engine speed is low and the boom is being lowered, if pump output is less than what is needed to fill the lift cylinder, reduced pressure will occur in the rod end of the cylinder.

When the cylinder pressure becomes less than tank pressure, the makeup valve is opened. The higher pressure of the tank port moves the poppet to the left, and oil from the tank flows in to prevent negative pressure (also called cavitation or vacuum). The makeup valve is non adjustable.

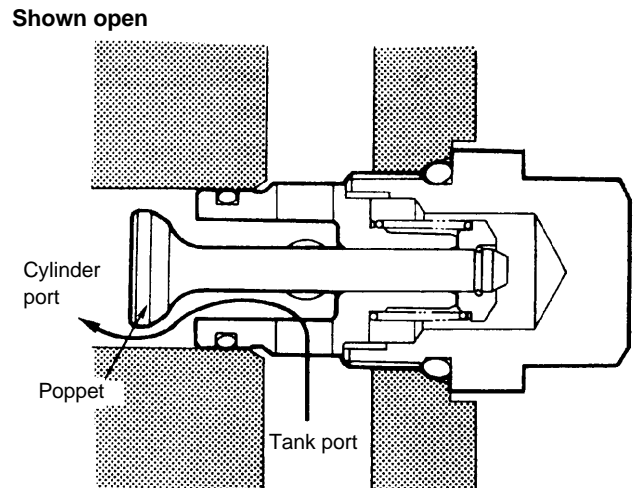

90Z 4203

Function

1. Steering plunger

The movement of the steering plunger is controlled by the oil pressure supplied from the steering valve (pilot) to the main steering valve oil pack.

At the center of the plunger, there is a variable orifice having chamfers (throttle grooves). This orifice controls the oil flow rate.

Also inside the steering plungers are check valves which apply a back pressure to oil returning from the cylinders.

2. Flow control plunger

The flow control plunger sends oil to the steering line depending on the displacement of the steering plunger. The excess oil goes to the loading line.

3. Main relief valve

The main relief valve controls the maximum operating pressure when turning the steering wheel.

4. Overload relief valves with make-up function

These valves prevent excessive oil pressure caused by external force and a vacuum in the steering oil line.

Main relief valve setting pressure	20.6MPa (210kgf/cm ²)
Overload relief valve setting pressure	24.5MPa (250kgf/cm ²)

Hydraulic Line Diagram

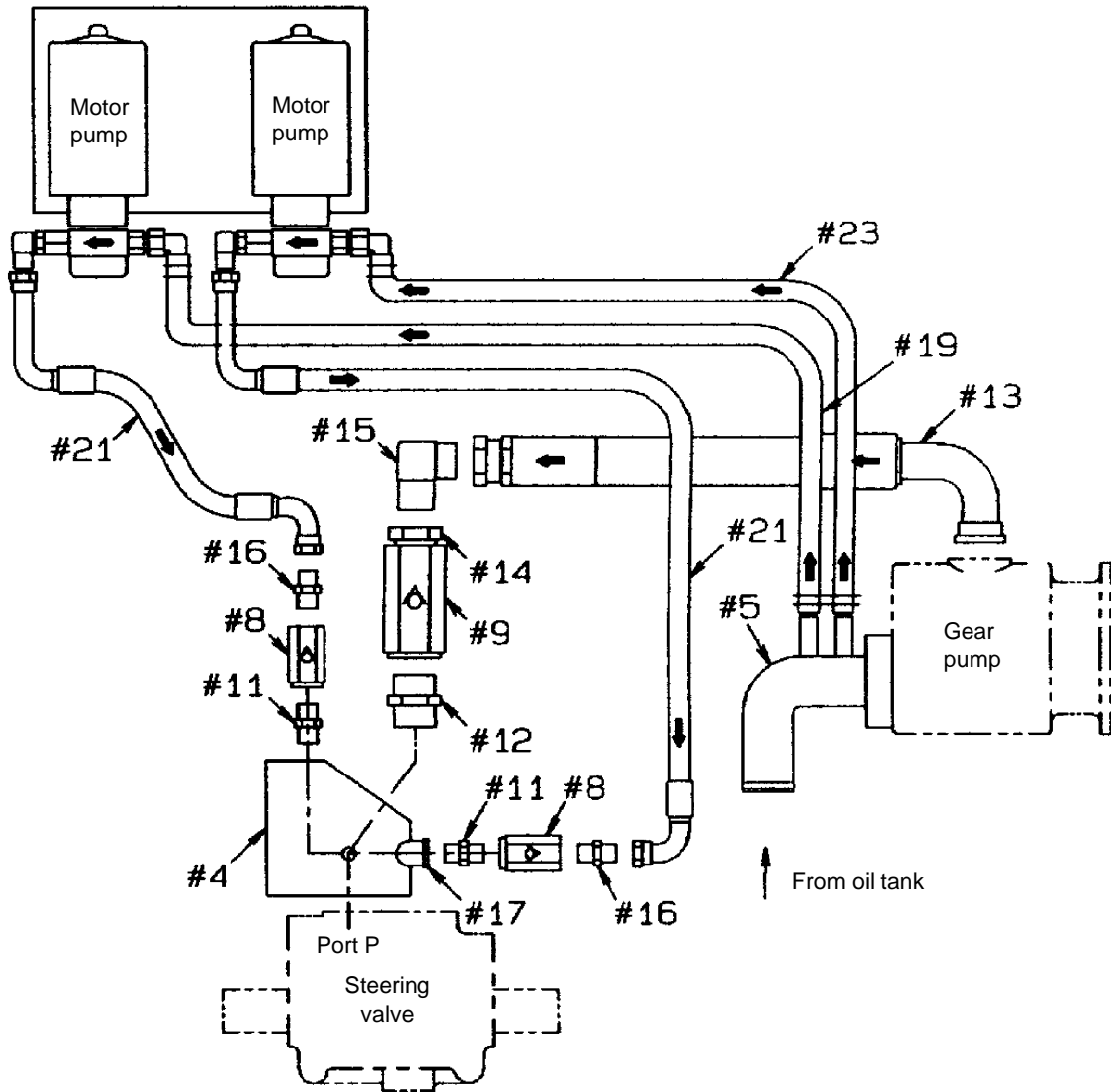

- | | |
|------------------------|--------------------------------------|
| 4. Block | 14. Connector |
| 5. Oil pipe | 15. Elbow fitting |
| 8. Check valve | 16. Nipple fitting |
| 9. Check valve | 17. Connector |
| 11. Nipple fitting | 19. Heat resisting low pressure hose |
| 12. Nipple fitting | 21. High pressure hose |
| 13. High pressure hose | 23. Heat resisting low pressure hose |

Brake Valve

Brake Valve (Main Valve)

(This is located in the left side of the operator's room)

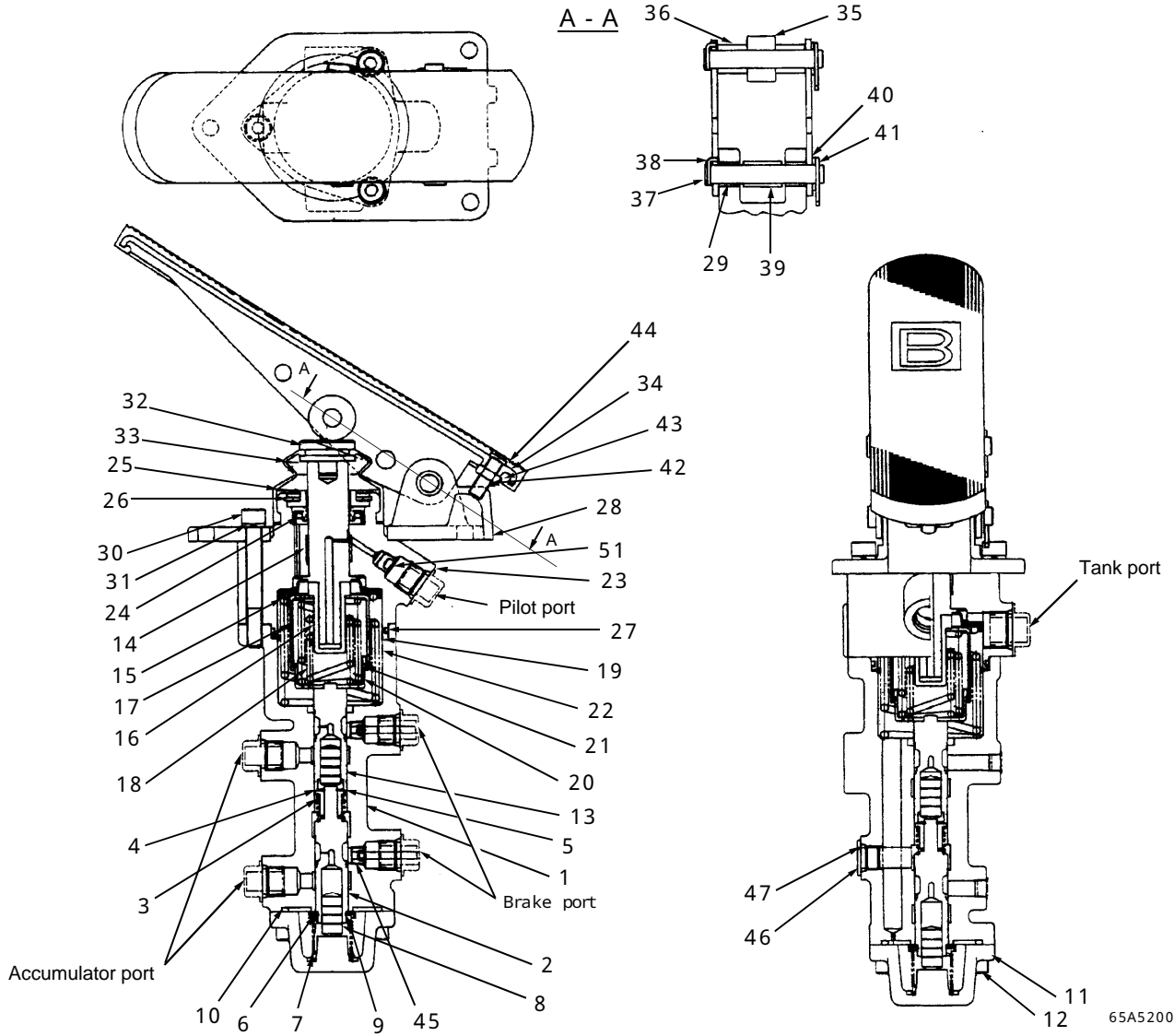

- | | | | | |
|----------------|-----------------|--------------------|------------------|-----------------|
| 1. Body | 11. Cover | 21. Stop ring | 31. Washer | 41. Pin |
| 2. Spool | 12. Bolt | 22. Spring | 32. Seat | 42. Screw |
| 3. Spring | 13. Spool | 23. Cover | 34. Pedal | 43. Nut |
| 4. Spring seat | 14. Input spool | 24. Oil seal | 35. Roller | 44. Pedal cover |
| 5. E-ring | 15. Spring seat | 25. Stopper | 37. Pedal pin | 45. Orifice |
| 6. Spring seat | 16. Sleeve | 26. C-ring | 38. L pin | 46. Plug |
| 7. Stop ring | 17. Case | 27. O-ring | 39. Pedal collar | 47. O-ring |
| 8. Plunger | 18. Spring | 28. Mounting plate | 40. Washer | 51. Orifice |
| 9. Spring | 19. Spring | 29. Bushing | | |
| 10. O-ring | 20. Case | 30. Bolt | | |

65A52003

Bleeding auto brake circuit

⚠ DANGER

While performing this work, do the following steps to keep from causing serious injury or death.

TAG THE MACHINE OUT OF SERVICE!

- Park on level ground, apply park brake, and block the tires with heavy wheel chocks.
- Do not work alone, and agree upon signals used before starting this work.
- If boom is raised during this service work, it is important to use a safety support that is strong enough to hold the weight of the boom and front of machine.
- Apply articulation stopper.

⚠ WARNING

This must be done after bleeding the air from the park brake circuit, and before bleeding the rest of the brake circuit at hub bleeder valves.

Purpose of this procedure is to remove all air from before the brake valves, where it can cause brake modulation troubles.

If air is left at auto brake valve, it can create problems with brake application due to air in brake valves.

1. Start machine, and run until you are certain that the unloader valve has reached the "cut off" pressure.
2. Shut off engine. **DO NOT RUN ENGINE!**
3. Manually apply and release auto brake solenoid 15 times, with a time lapse of 5 seconds between each application. Refer to illustration below to see how to do this.
4. Continue with bleeding of air from brakes at the wheels.

Auto brake solenoid valve

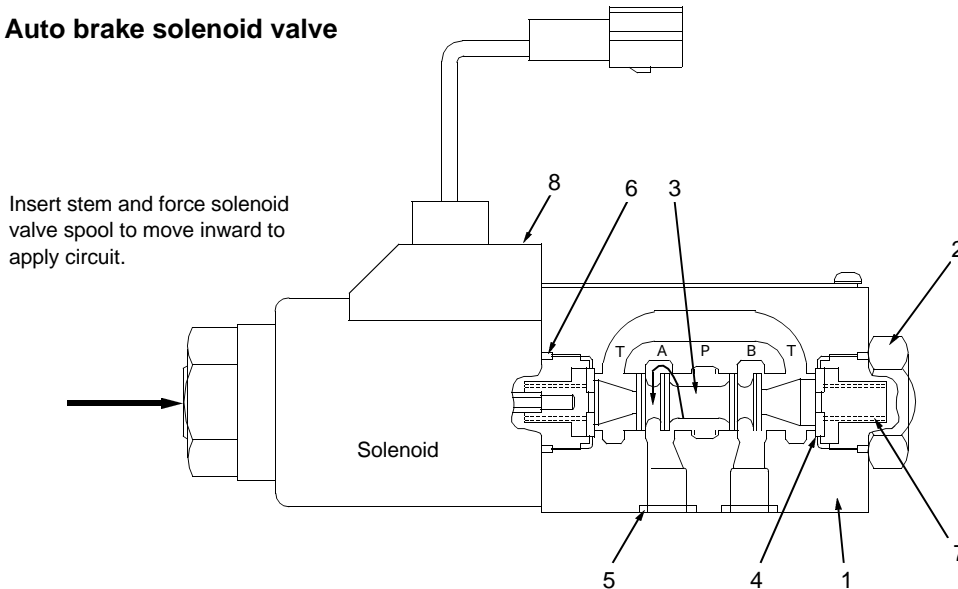

Solenoid Valve (for auto brake)

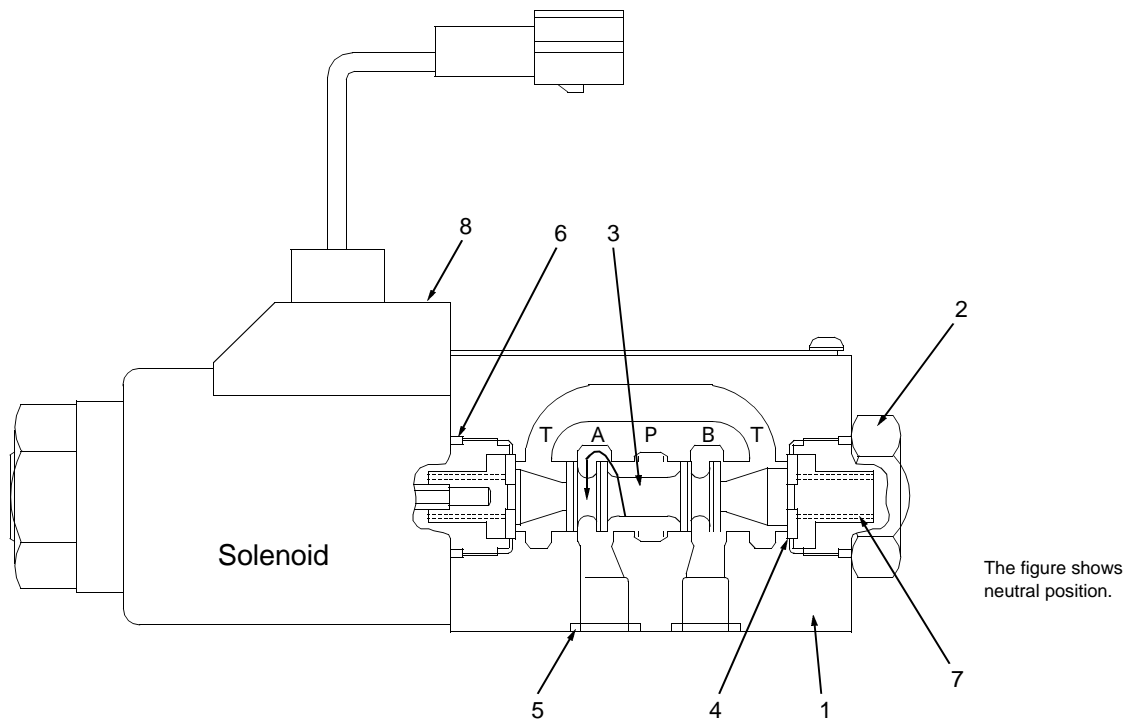

95C52018

Installation position

Installed on the hydraulic tank (the left side of the rear chassis)
 (beside the parking brake solenoid valve)
 (Refer to "Layout of Brake Units")

Operation

Auto-braking will occur under the following conditions:

1. When shifting between forward and reverse is done with the shift lever in " A " position and the machine speed is over 12 km/H.
2. When the specified speed limit for each speed range is reached.

(Refer to the Electrical Group Section 62 for the details of Auto brake operation.)

Speed limit for Auto brake

Speed range	Speed limit
1st	Approx. 15km/H
2nd	Approx. 22km/H
3rd	Approx. 36km/H
4th	Approx. 36km/H

Electrical Wiring Diagram(2/2)(95ZIV) (97C3-9001 ~ 9050)

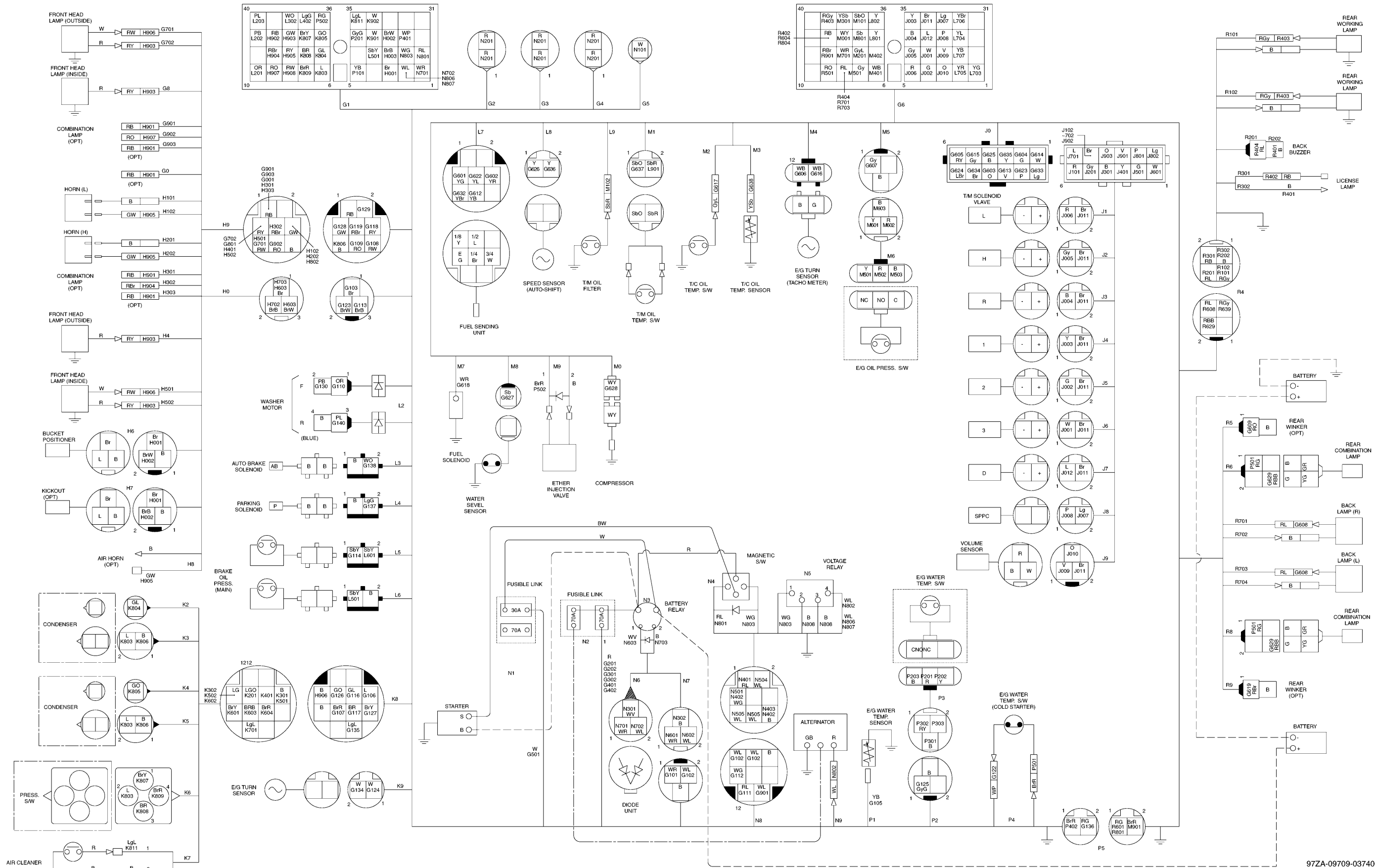

97ZA-09709-03740-2

Layout of Electrical Equipment Around Battery Relay

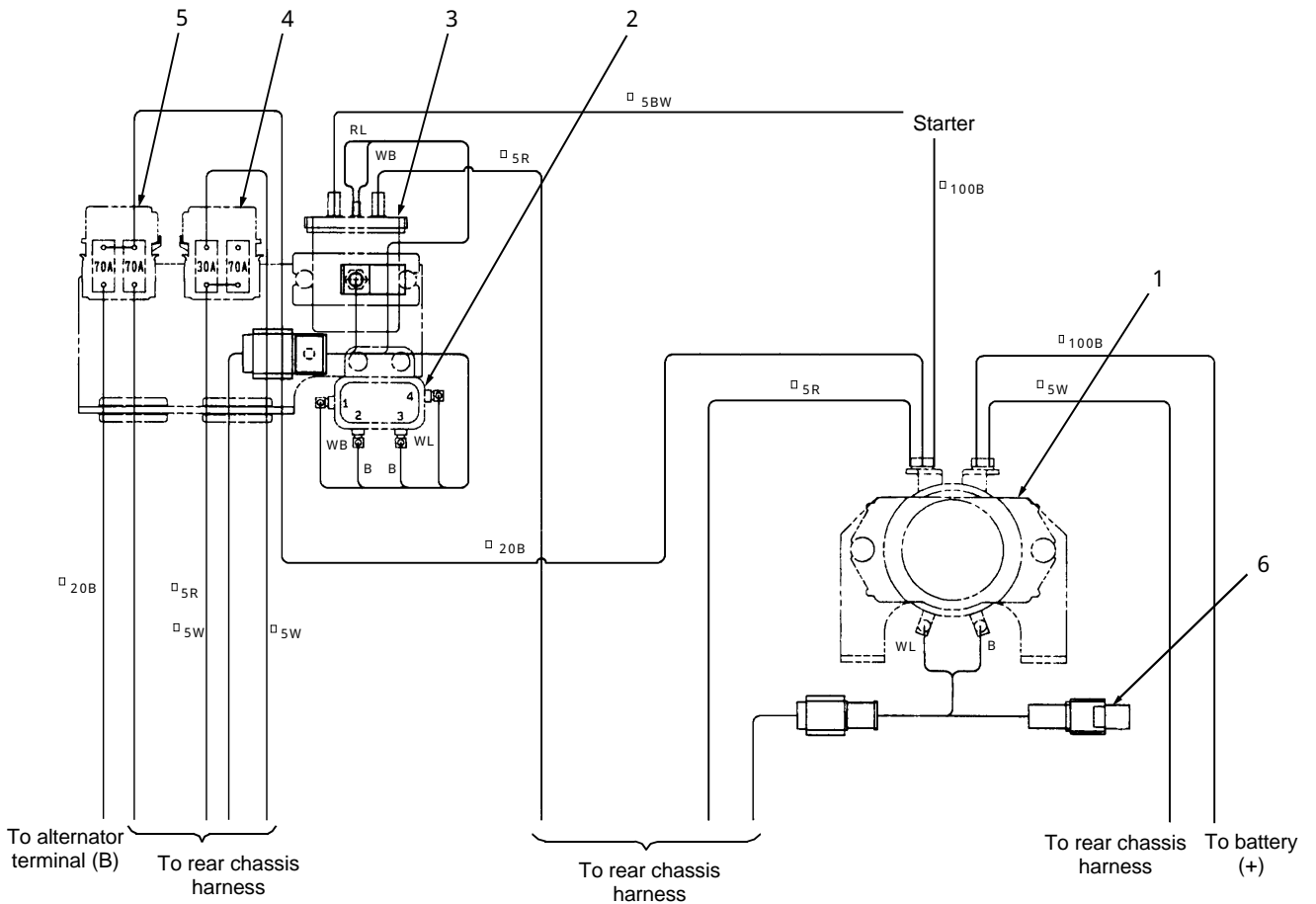

97ZA6206

1. Battery relay
2. Voltage relay
3. Magnet switch
4. Fusible link (30A, Spare 70A)
5. Fusible link (70A, 70A)
6. Diode unit

Engine Stop Circuit

When the starter switch is turned to ON, the fuel valve solenoid is activated to open the fuel valve to start the engine.

When the starter switch is turned to OFF, the fuel valve is closed to stop the engine.

If the fuel valve fails, or if the electric system malfunctions, the emergency starting function can be used as follows.

Screw the manual operation screw of the fuel valve to open the fuel circuit. And then the engine can be started.

Fuel valve	
Rating voltage	DC24V
Coil resistance	Approx. 30

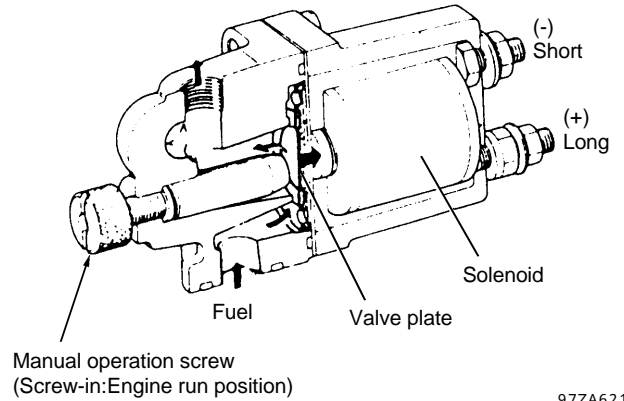

97ZA6218

FUEL VALVE

Transmission cut - off (Inching)

The operator may select, by means of a switch, the transmission cut-off function. In the "ON" position the brake pedal (left or right), when depressed, will place the transmission in neutral and apply the service brakes. In the "OFF" position the brake pedal operates the service brakes only.

When the brake pedal (left or right) is depressed with the selector switch "ON", a pressure switch (inching) is actuated (LED ON). The input LED indicates: "I" on the controller lights up. The transmission controller turns off the power to the forward / reverse clutches (L. H. R.), causing the transmission to be placed in neutral. The dash board monitor lamp "N" lights up.

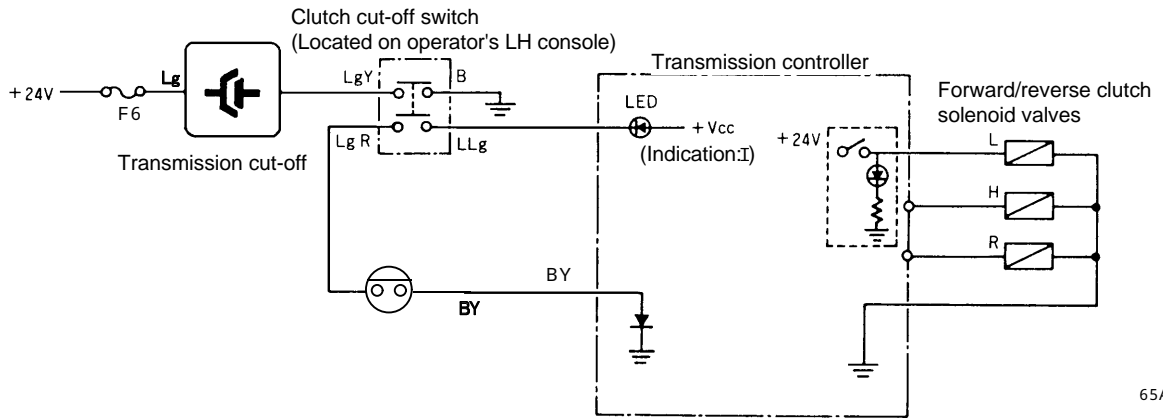
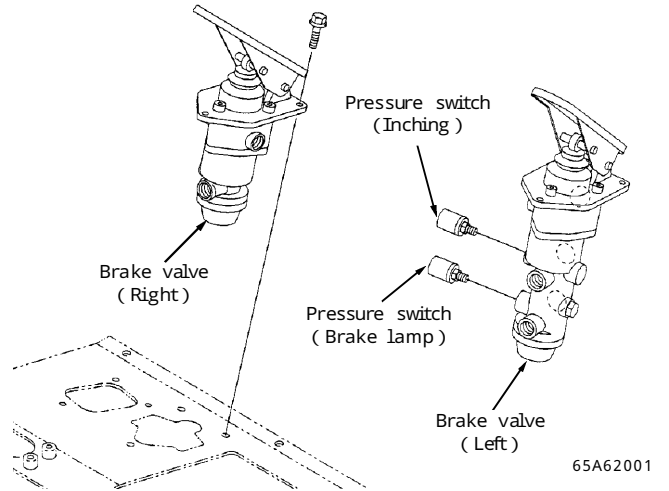

Inching pressure switch

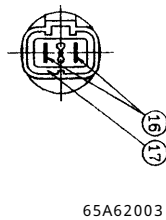
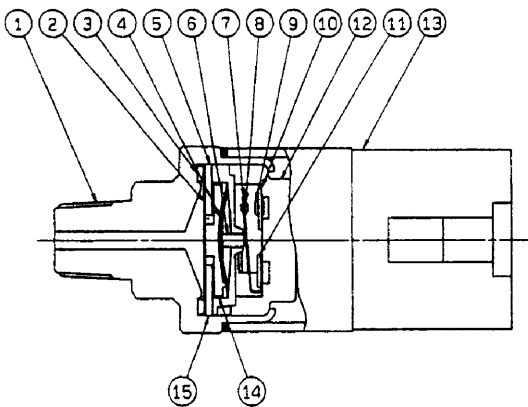

1. Case
2. Seal
3. Packing
4. Disc
5. Inner lid
6. Guide pin
7. Spring
8. Contact
9. Contact
10. Connector
11. Connector
12. Base
13. Cover (Connector)
14. Guide
15. Stopper
16. Connector
17. Housing

Operation pressure

1.13 ± 0.15MPa(11.5 ± 1.5kgf/cm²)

Contact

Normal open

Return pressure

0.90 ± 0.1MPa(9.2 ± 1.0kgf/cm²)

Monitor Circuit

Monitor

During operation, if a problem of a unit is detected, the monitor lamp will light to inform the operator. For some problems, the buzzer will also sound, and the centralized alarm lamp will also flash.

When turning the starter key to "ON" position, all the monitor lamps turn on for 3 seconds, it shows that those lamps are normal (not burnt out).

Electric Detent Circuit

Bucket positioner

After dumping, if the control lever is set to the "roll-back" position, the control lever will be held at that position until the bucket is tilted to the set angle. This is because the detent magnet in the pilot valve is energized so that the holding plate connected to the spool is held by magnetic force. When the bucket is positioned at the set angle, the rod will retract from the proximity switch. The proximity switch, therefore, is turned off, and the coil of the pilot valve is de-energized and demagnetized. The control lever is automatically returned to the neutral position by the spring. As a result, the bucket is set to the selected digging angle automatically.

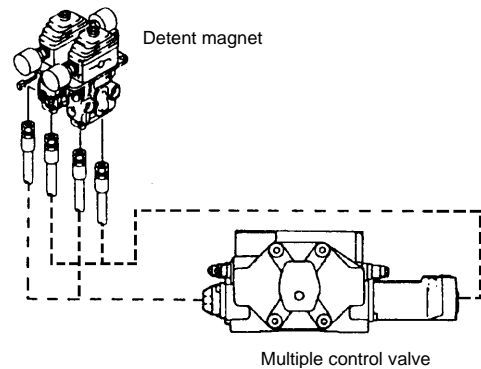

Boom kick-out unit (optional)

While the boom is being raised, the control lever is held at the "raise" position. When the boom is raised to the set height, the boom kick-out unit automatically returns the control lever to the "neutral" position. The detent functions and the units are the same way as those of the bucket positioner.

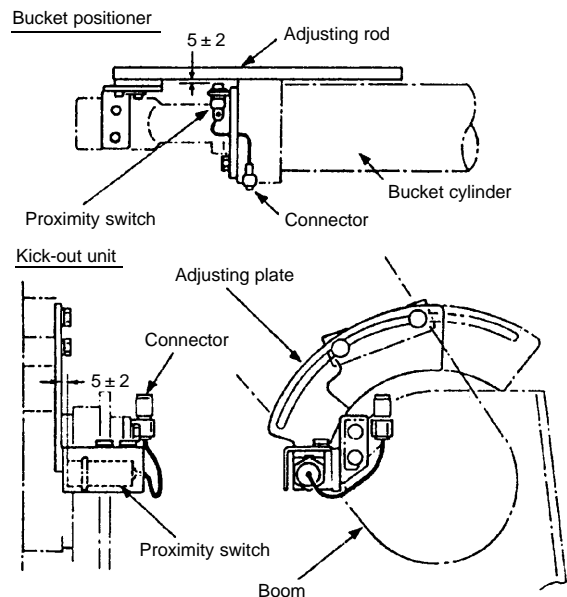

Float

When the control lever is set to the "float" position, the control lever will be held at the "float" position. For the "float" position, manually reset the control lever. The float magnet is energized whenever the starter switch is "ON".

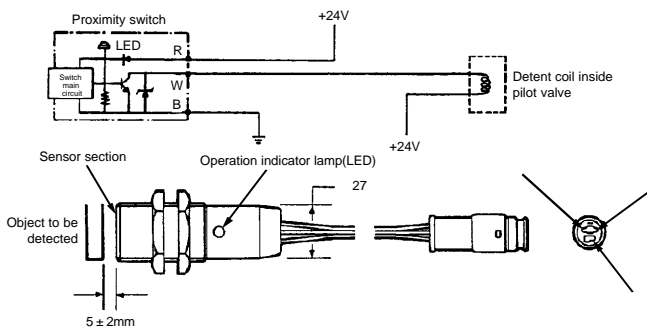

70V62005

Adjusting clearance

Adjust the clearance between the sensor and the adjusting rod or adjusting plate to 5 ± 2 mm. In this condition, the operation indicator lamp (LED) is on, and the circuit between switches (2)-(3) is on.

In parking status(during engine operation)

LED on - - Related LED on (depending on input switch position)		Machine condition		Usual parking Emergency	Circuit protector OFF	Circuit protector on when controller failure alarm is on
		Shift lever position	Neutral Other than neutral			
Input side LED window	F	Shift lever position · F				
	R	Shift lever position · R				
	1	Shift lever position · 1				
	2	Shift lever position · 2				
	3	Shift lever position · 3				
	A	Shift lever position · A				
	M	Automatic shift cancel				
	S	Shift switch ON				
	P	Parking switch OFF (running status)				
	I	Inching switch ON				
		Machine speed				
		Engine revolution		Related character:ON		
Output side LED window	X	T/M controller (when working properly:ON)				
	RR	Back up relay ON		()		
	DC	Modulator valve 2 ON				
	L	Low clutch sol. valve ON				
	H	High clutch sol. valve ON				
	R	Reverse clutch sol. valve ON				
	BZ	Buzzer				
	N	Neutral relay ON				
	BRK	Auto brake sol. valve ON				
	1	1st clutch sol. valve ON				
	2	2nd clutch sol. valve ON				
3	3rd clutch sol. valve ON					

() : LED ON only shift lever in reverse position

Electrical Wiring Connection

When performing the diagnostic procedure, connect the diagnostic switch coupler to the controller as shown below.

1. Necessary parts

Diagnostic switch assembly (A)

Part Number : 35020-20510

- Diagnostic sw
- Reset sw
- Harness assembly

2. Connection procedure

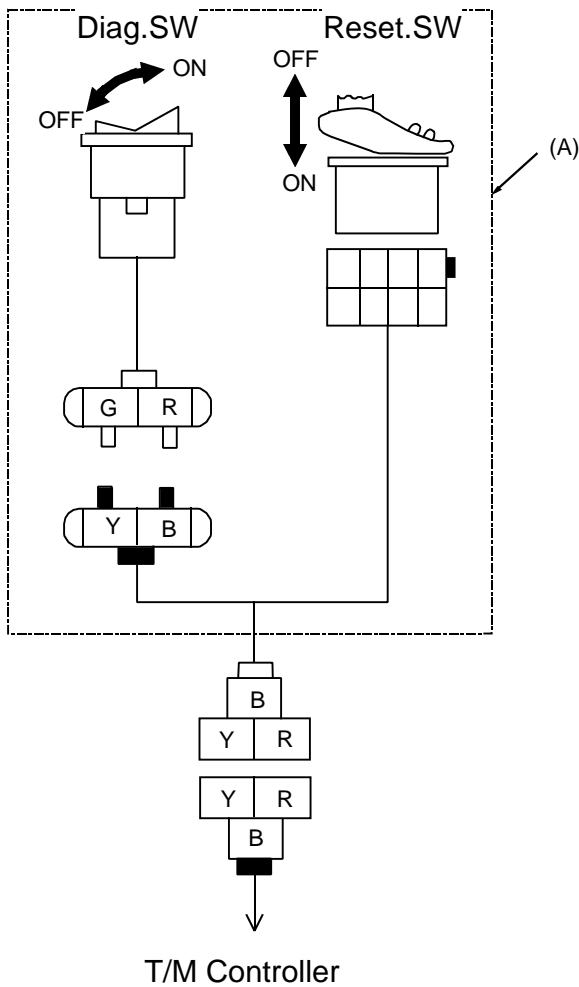

<Step 2>Check modulator valve(1)or(2)

Using a tester volt ohm meter, measure resistance between both terminals of the connector.

Decision	Resistance of modulator valve (1) or (2) *
Normal	About 24 Ohms
Abnormal (Broken wire)	

***Check for sticking**

If necessary, disassemble the valve and inspect.

<Solution>If a broken wire or sticking valve is found, replace the entire modulator valve assembly.

To check the coil and the diode:

Use an analog (needle type) Volt-Ohm Meter (VOM) with an Rx1 setting. Adjust the meter's zero setting. Measure the resistance through the coil in both directions by reversing the test probes. The meter reading will be different for each measurement if the diode is good. If the diode is defective the meter will read the same in both directions. If the diode is defective replace the solenoid valve assembly. A defective diode can cause a controller failure over time.

Speedometer circuit

Speed sensor

The speed sensor is installed on the output shaft of transmission (parking brake part) and is transmitting the pulse according to the machine speed.

Output pulse : 16 pulse/1 rev. sensor

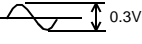
Output voltage : $0.3V/21min^{-1}(rpm)$ 

Odometer converter

The converter is to drive the odometer and is installed under the instrument panel.

Tachometer



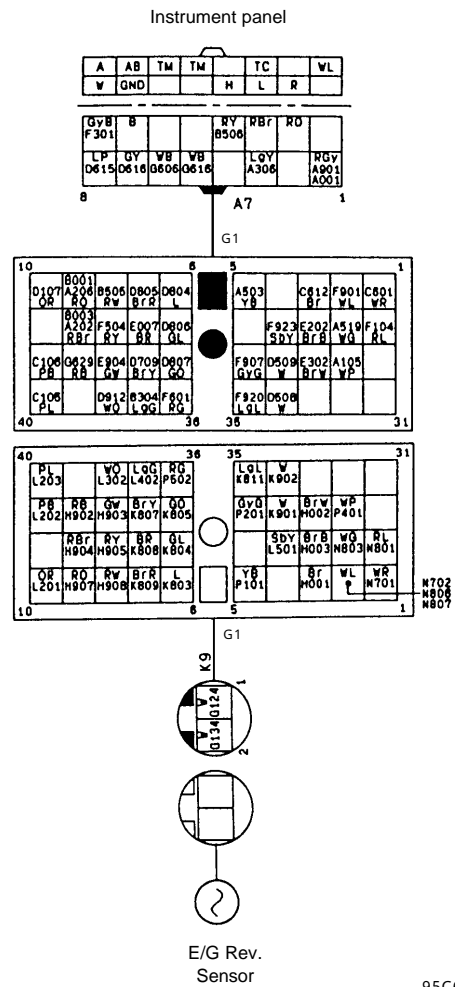









Input frequency (Hz)	Rev min ⁻¹ (rpm)
66.67	500 ± 50
200	1500 ± 45
333.33	2500 ± 125



95C62020

Monitor symbols and actuation conditions

Error warning lamps (which are lit in red)

Layout drawing No.	Monitor item	Monitor lamp	Lighting condition	Interlock with buzzer	Interlock with lamp test	Remarks
10	Controller error		When controller CPU is out of order	○	○	
11	Brake oil pressure error		When oil pressure at unloader valve accumulator port is 3.9 ± 0.3 MPa (40 ± 3 kg/cm ²) or less	○	○	
12	Engine oil pressure error		When engine oil pressure is 0.1 MPa (1.5 ± 0.1 kg/cm ²) or less while engine is rotating	○	○	
13	Engine coolant temperature error (high)		When coolant temperature is 101 ± 2 °C or more	—	○	
14	Torque converter (transmission) oil temperature error (high)		When coolant temperature is 120 ± 5 °C or more	—	○	
15	Air cleaner clogging		When suction resistance is 635 ± 58 mmAq or more	—	○	
16	Charge		When charge system is defective	—	○	
17	Transmission oil filter clogging		When differential pressure is 0.3 MPa (3.15 ± 0.28 kg/cm ²) or more at oil temperature of 50 ± 2 °C or more	—	○	
9	Central warning		When either of alarms 10, 11 and 13 to 16 above has occurred	—	○	Flashing type
6	Auto brake actuation		When auto brake is actuated	○	○	
25	Steering circuit error (option)		When steering is operated while engine is running and steering oil pressure is 0.4 MPa (4 kg/cm ²) or less	—	○	
26	Engine coolant level error		When radiator coolant level is low	—	○	

Specifications

Air conditioner assembly specifications

Cooling capacity	4.7 ± 0.47 kw (4,000 ± 400 kcal/h)	
Air quantity	550 ± 55 m ³ /h	
Rated voltage	24 V	
Number of rotations of motor	3,400 min ⁻¹	
Power consumption	Motor	225 W
	Magnet	40 W or less

Heater specifications

Heat radiation quantity	5.9 ± 0.59 kw (5,100 ± 510 kcal/h)
Air quantity	450 ± 45 m ³ /h
Number of rotations of blower	3,650 min ⁻¹
Power consumption	215 W
Standard voltage	24 V

(Difference in temperature: 65°C, water flow rate: 6 L/min)

Air conditioner line routing

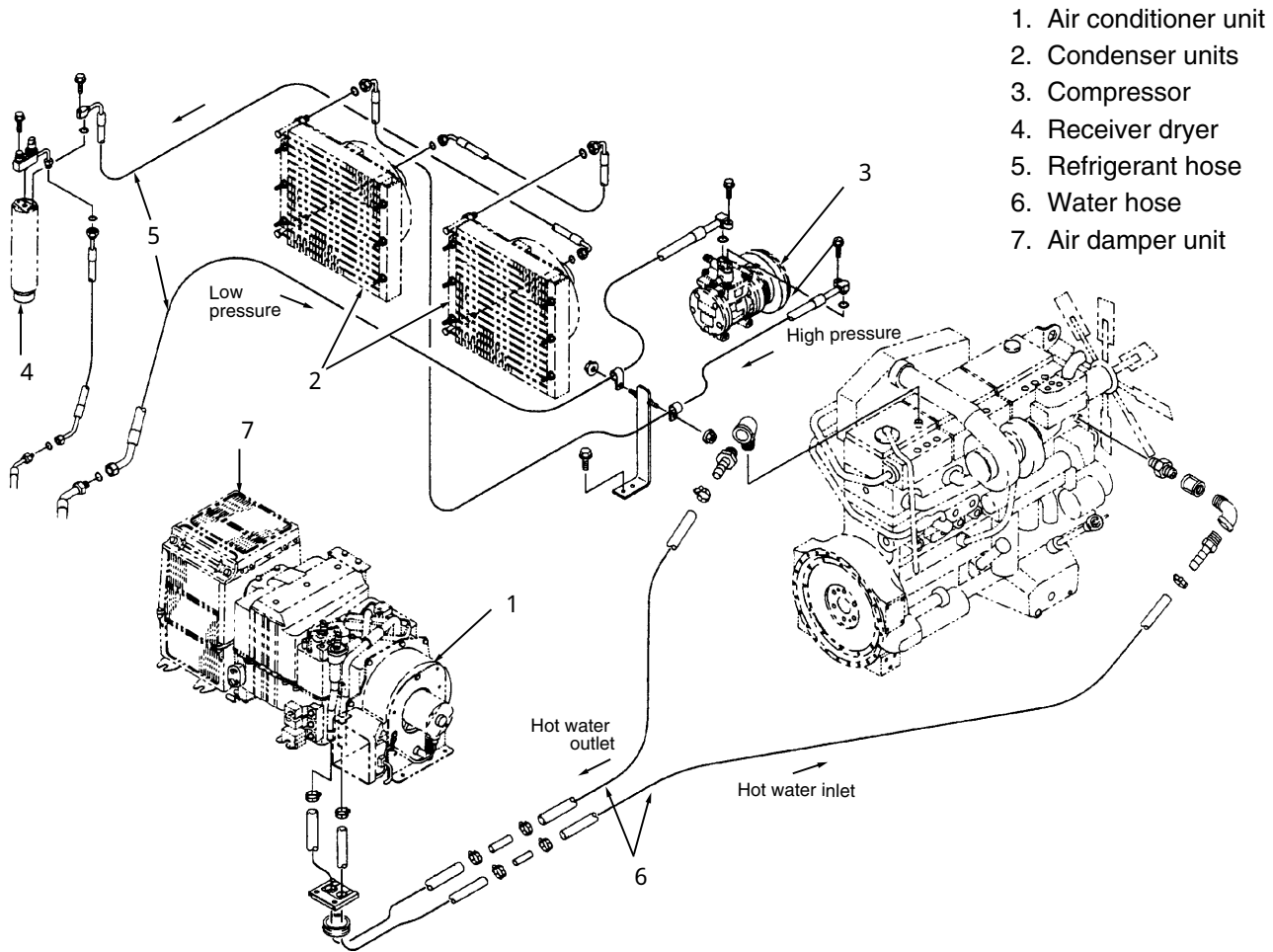

1. Air conditioner unit
2. Condenser units
3. Compressor
4. Receiver dryer
5. Refrigerant hose
6. Water hose
7. Air damper unit

Functions of components

Control unit

The control unit consists of a control panel which allows to operate the air conditioner and a control amplifier which controls each function in accordance with operation of the switches provided on the control panel.

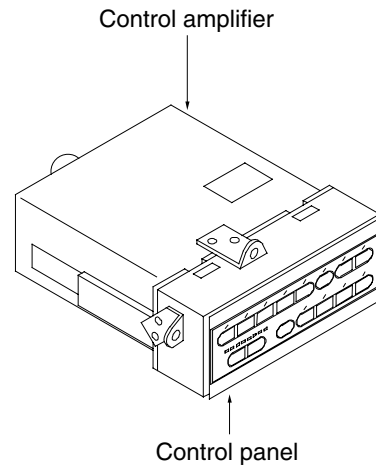

65K72003

Control panel

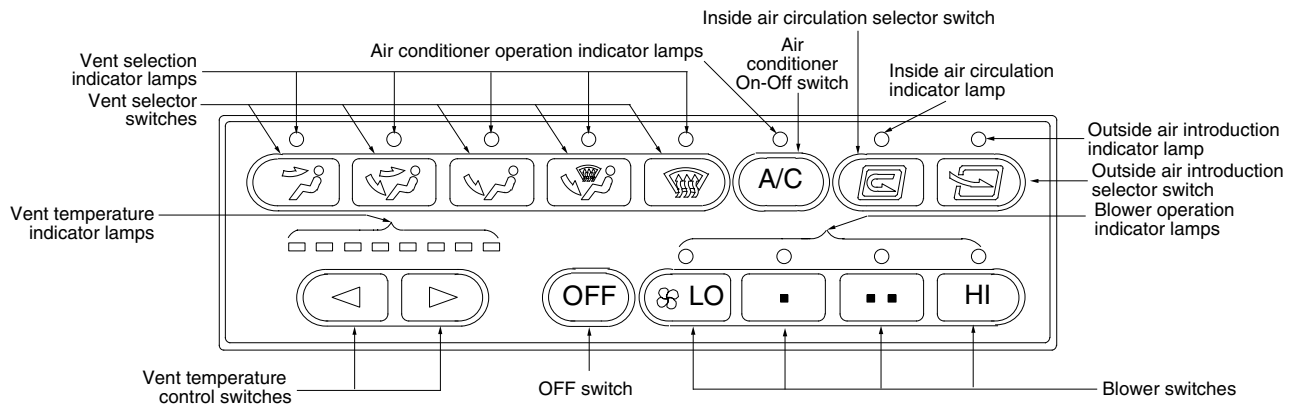

When each switch is pressed and the control amplifier receives corresponding operation signal, buzzer sounds instantaneously and the following operations are performed.

Actuator for vent selection

The actuator operates in accordance with operation of the switches provided on the control panel. The actuator rotates only while the power is applied from the control amplifier on the area between (A) and (B). The actuator rotation direction (normal or reverse) is determined by the direction of the power applied on the area between (A) and (B).

When the motor rotates, the moving contact slides in the resistor on the fixed plate. When the detected position of the moving contact (which is linked to the control lever) becomes equivalent to the indication on the control panel (that is, when the electric potential becomes equivalent), the power of the motor turns off and the motor stops.

Specifications

Voltage	24 VDC	
Load torque	0.3 N·m (3 kgf·cm)	
Number of rotations	10 min ⁻¹	
Current	75 mA	
Voltage applied terminal	Terminal (A)	Face side
	Terminal (B)	Def side

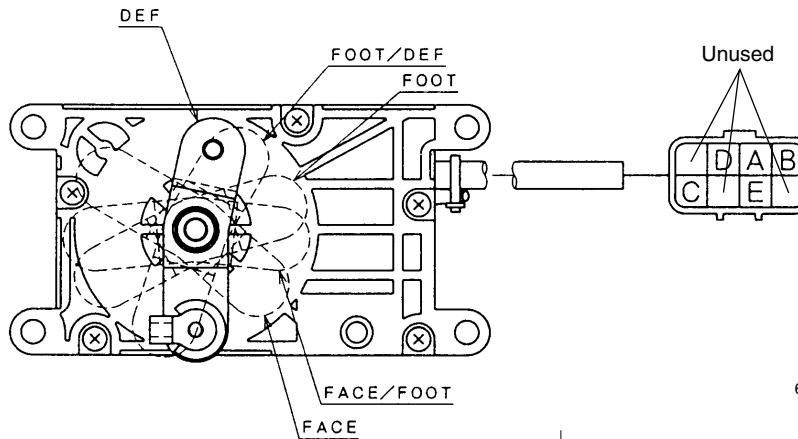

65K72013

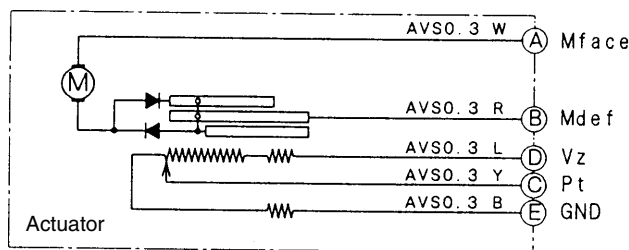

Circuit diagram

65K72014

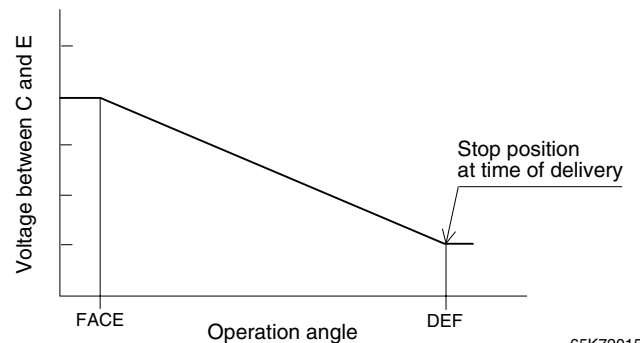

Relation of potentiometer output and initial value

65K72015

Troubleshooting the actuator for vent selection

Item	Symptom	Cause	Action
Motor is locked (disabled).	·Actuator does not rotate.	1. Motor 2. Control unit	1) Repair/replacement
Contact is contacting poorly.	·Vent temperature indicator lamps do not light in accordance with preset pattern. ·Actuator does not stop in accordance with preset pattern.	1. Fixed plate 2. Moving contact 3. Control unit	1) Repair/replacement

Access tube

The access tube mounted on the outlet side of the receiver dryer consists of a pressure switch, a sight glass and a charging valve on the high pressure side.

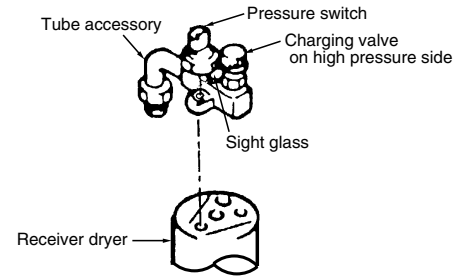

97ZA7255

Pressure switches

The pressure switch detects the pressure on the high pressure side of the cooling circuit, and stops the compressor when detecting any abnormality so that damage of the equipment in the cooling circuit can be prevented.

There are three types of pressure switches, high pressure type, medium pressure type and low pressure type, which function as shown in the table below.

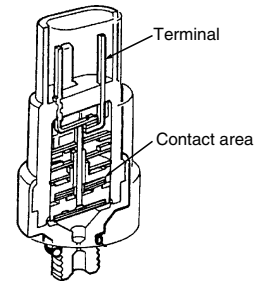

97ZA7256

Switch	Function	Switching pressure kPa (kgf/cm ²)	Switch operation confirmation method	Causes of abnormal pressure
High pressure switch	When pressure between compressor and expansion valve becomes abnormally high, this switch shuts down power supplied to compressor magnetic clutch to protect circuit.		Pressure switch coupler Check conductivity between A and B.	Heat radiation of condenser is insufficient due to clogging in condenser or defective rotation of condenser fan.
Medium pressure switch	When detecting fluctuation of pressure between compressor and expansion valve, this switch gives a signal to control amplifier about whether to rotate condenser fan motor at low speed or high speed. While this switch is ON, fan motor rotates at high speed. While this switch is OFF, fan motor rotates at low speed.		Check conductivity between C and D in pressure switch coupler shown above.	_____
Low pressure switch	When pressure between compressor and expansion valve becomes abnormally low due to refrigerant leak, this switch shuts down power supplied to compressor magnetic clutch to prevent seizure of compressor caused by insufficient compressor oil which decreased together with refrigerant.		Check conductivity between A and B in pressure switch coupler shown above.	Refrigerant leak from a part of circuit

2) Evacuating the system

- (1) Open both the high pressure (Hi) valve and the low pressure (Lo) valve of the gauge manifold.
- (2) Turn on the switch of the vacuum pump, and evacuate until the degree of vacuum becomes -750 mmHg or less (for approximately 20 to 30 minutes).
- (3) After finishing evacuation, close both the high pressure valve and the low pressure valve of the gauge manifold. Then, turn off the switch of the vacuum pump.

IMPORTANT

If you stop the vacuum pump before closing each valve of the gauge manifold, the circuit in the vacuum status is released to the atmosphere. First close each valve.

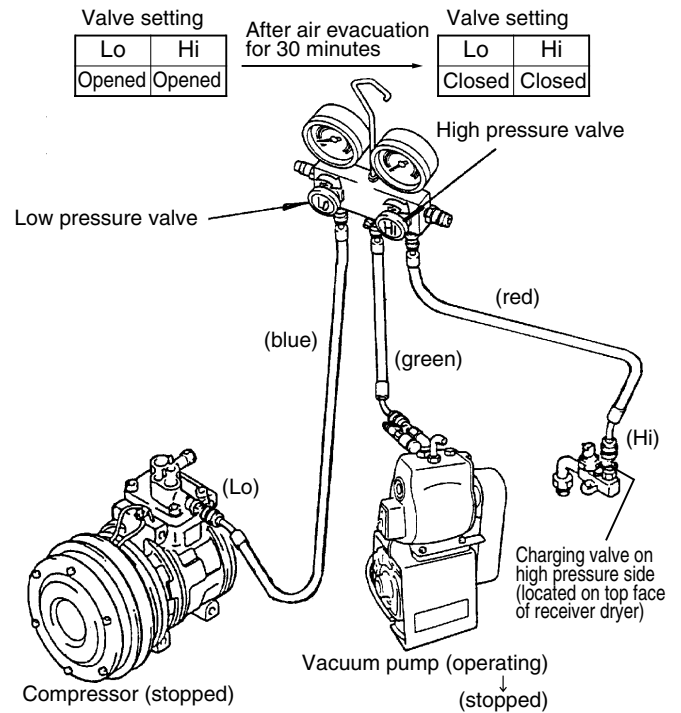

97ZA7275

3) Checking for leaks

Leave the circuit for 5 minutes or more while each valve of the gauge manifold is closed. Then, make sure that the pointer of each gauge does not move. If the pointer of the low pressure gauge moves toward "0", a leak has occurred somewhere in the circuit. Tighten the connection areas of the piping, evacuate the system again, then make sure that there is no leaks.

IMPORTANT

Make sure to tighten the connection areas of the piping at a specified tightening torque. For the tightening torque, refer to the volume "Maintenance Standard".

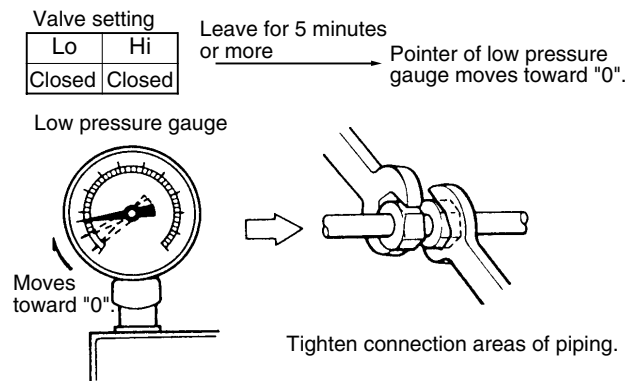

97ZA7276

Adjustment of water valve and air mixing dampers

1. Adjustment of water valve

- 1) Set the vent temperature control switches provided on the control panel to maximum cooling.
- 2) Make sure that the water valve is completely closed. If it is not, remove the link stopper of the clamp A and adjust the position of the link rod A.

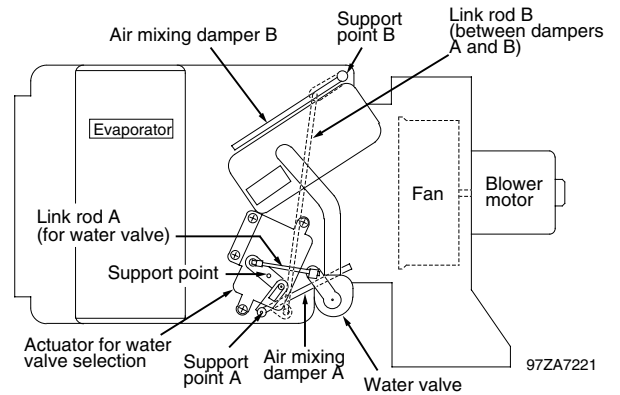

Link/damper position in maximum cooling status

2. Adjustment of air mixing damper B

- 1) In the status described in 1 above, make sure that the air mixing damper B closes off the heater radiator core completely.
- 2) If the air mixing damper B is not located in the completely closed position, remove the link stopper of the clamp B and adjust the position of the link rod B.

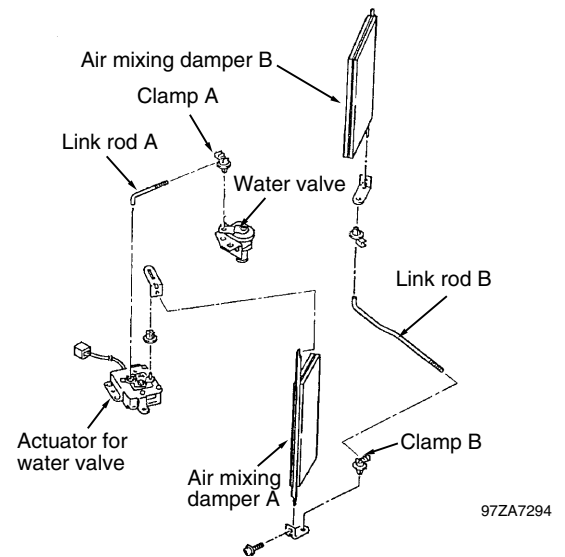

Link diagram between water valve and air mixing damper

TROUBLESHOOTING 01-1
MEASUREMENT FOR PERFORMANCE CHECK 03-1

Torque Converter and Transmission Group

5. Large time lag at starting or changing speed / direction		Symptoms / check point										Solution
		Large time lag at all the shift lever positions	Main oil pressure rises too slowly at all the shift lever positions	Controller output LED "DC" indicator does not light properly	Main oil pressure is too low at all the shift lever positions	Large time lag at a certain shift lever position only	Clutch oil pressure is too low or rises too slowly at a certain shift lever position only	Time lag just after using the inching brake	Torque converter oil overheats	Abnormal noise from charge pump (shrieking)	Charge pump extremely heated	
Possible cause												
	Defective torque converter pump											Disassembly&repair
	Harness of modulator valve (1) disconnected (or sticking in OFF position)											Disassembly&repair
	Malfunctioning pressure difference sensor											Disassembly&repair
	Defective controller											Controller replacement
	Internally leaked clutch oil											T/M disassembly and repair
	Malfunctioning inching proximity switch											Switch replacement
	Restricted suction line-pinched, internally defective											Replace hose

CLICK HERE TO **DOWNLOAD** THE COMPLETE MANUAL

- Thank you very much for reading the preview of the manual.
- You can download the complete manual from: www.heydownloads.com by clicking the link below



- Please note: If there is no response to CLICKING the link, please download this PDF first and then click on it.

CLICK HERE TO **DOWNLOAD** THE COMPLETE MANUAL

Hydraulic Group

<p>5. Bucket positioner (kick-out) does not work</p> <p>Check before starting work</p> <p>(1) Check the fuses.</p> <p>(2) Check that the distance between the proximity switch and detection bar is properly adjusted. (5mm ± 2[1/8 ~ 1/4])</p> <p>(3) Check all the connectors of the electrical power line to be sure they are properly connected.</p>		Symptoms / check point										
		LED lamp of the proximity switch does not light (key on & metal plate in front of sw. face)	Remove the connector of the proximity switch, and connect the red and white wires of the connector to each other on the chassis side. Check that the lever is held properly.	Magnet coil resistance value is indicated as infinity or 0								
Possible cause												S o l u t i o n
Defective proximity switch												Proximity switch replacement
Broken magnet coil inside pilot valve												Magnet replacement
Disconnected electrical power line												Repair

Brake Group

<p>6. Auto brake does not work</p> <p>Check before starting work</p> <p>(1) Check the fuses of the electrical system.</p> <p>(2) Check the main accumulator pressure.</p>		Symptoms / check point							
		Auto brake works when the manual release knob of solenoid valve for auto brake is pushed in	It is not possible to release the parking brake	Brake does not work well even when the brake pedal is pressed	Heavy movement of the manual release knob of solenoid valve for auto brake	Automatic speed change is unstable	Coil of the solenoid valve has extremely high resistance	Controller output LED "BRK" will not light even when shifted to reverse/forward with machine high speed	
Possible cause									S o l u t i o n
	Defective controller								Replacement
	Defective machine speed sensor								Replacement
	Disconnected or defective electrical line								Inspection&repair
	Defective coil of auto brake solenoid valve								Replacement
	Sticking spool of auto brake solenoid valve								Inspection&repair
	Accumulator pressure in main accumulator is low								Inspection&repair
	Defective service brake system								Inspection&repair

Measuring Engine Speed

WARNING

Unexpected movement of the machine may cause an accident resulting in injury or death. Therefore, to provide repair service with the engine running, be sure to observe the following items:

- Park the machine on level ground.
- Apply the parking brake.
- Block the tires with chocks to prevent the tires from moving.
- Determine the signals between the service men.
- Prohibit any person from walking into dangerous areas.
 - Near articulation area of the machine
 - Under the machine
 - Around the engine
 - In front of or behind the machine

CAUTION

Do not touch the fan or V-belt of the engine or a high-temperature section if the engine is running. An accident resulting in injury may occur.
 Be sure to stop the engine before you open the side cover of the engine room. Keep all guards in place.
 Avoid high temperature components even after the engine is stopped.

- **Measurement instrument**
 - Tachometer drive port
- **Warm-up the engine before measuring the engine speed**
- **Standard measurement value(min⁻¹)**

Minimum no-load speed (LI)	800 ± 50
Maximum no-load speed (HI)	2,300 ± 50
Maximum speed in torque converter stall mode	2,180 ± 100
Maximum speed in multiple control valve relief mode	2,160 ± 100
Maximum speed in torque converter stall plus multiple control valve relief mode	1,650 ⁺¹⁵⁰ ₋₁₀₀
Maximum speed in torque converter stall plus steering valve relief mode	1,830 ⁺¹⁵⁰ ₋₁₀₀

Adjusting Steering Stopper

⚠ WARNING

Unexpected movement of the machine may cause a serious injury or death. There is a possibility that a service man may be crushed in the articulation area if the machine unexpectedly turns during steering stopper adjustment. To prevent such an accident, be sure to observe the following items:

- Stop engine before adjusting steering stopper
- After adjusting steering stopper, prohibit any person near articulation area of the machine when checking operation.

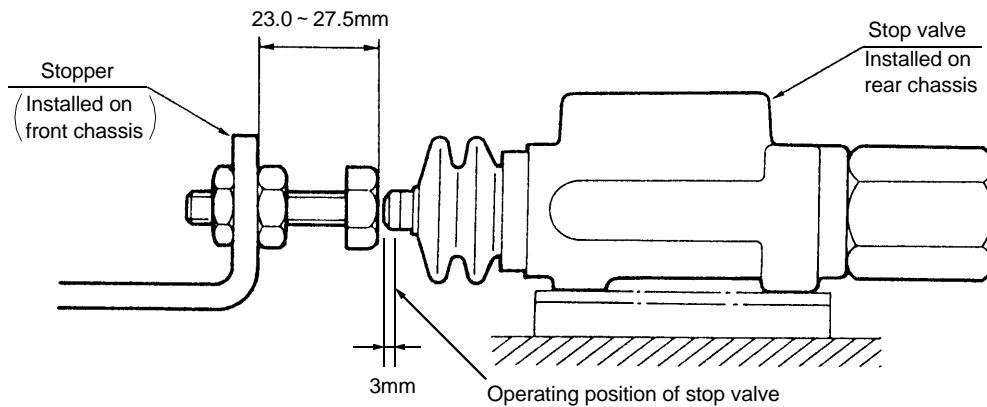

90C03007

- Adjust the steering stopper so that the stopper works when the stop valve is depressed 3 mm.
- Adjust the dimension of the stopper bolt shown above so that the stopper works when the clearance of the stopper on the chassis becomes 28 ~ 48 mm (an articulation angle of 37 ~ 35 °) is reached.
- After adjusting, turn the steering wheel one turn (slowly) over a period of 5 seconds to check the stopper for operation.

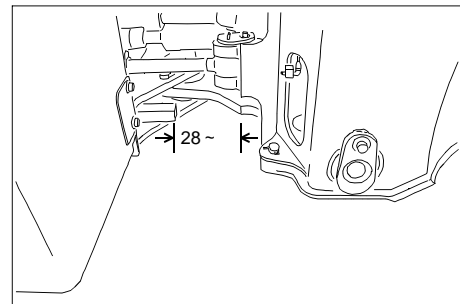

Adjusting dimension (for reference)

Articulation angle	40 °	39 °	38 °	37 °	36 °	35 °	34 °
Clearance of body stopper (mm)	0	10	19	28	38	48	57
Length of setting bolt (mm)	16	18.5	20.5	23.0	25.0	27.5	30.0

Measuring Accumulator Charging Time

⚠ WARNING

Unexpected movement of the machine may cause an accident resulting in injury or death. Therefore, to provide repair service with the engine running, be sure to observe the following items:

- Park the machine on level ground.
- Apply the parking brake.
- Block the tires with chocks to prevent the tires from moving.
- Determine the signals between the service men.
- Prohibit any person from walking into dangerous areas.
 - Near articulation area of the machine
 - Under the machine
 - Around the engine
 - In front of or behind the machine

⚠ CAUTION

Do not touch the fan or V-belt of the engine or a high-temperature section if the engine is running. An accident resulting in injury may occur. Avoid high temperature components even when the engine is stopped.

• Measurement instrument

- Hydraulic pressure gauge :
 - 19.6MPa (200kgf/cm²) with 2.5 ~ 3m hose
 - Pressure measurement port :PF1/2

- Stop watch

Note: For safety, route the gauge to an area where it may be safely read by the person doing the test.

• Standard measurement value (sec)

Engine speed: Low idle

Unloader valve pressure		24 ± 5
3.9MPa (40kgf/cm ²)	11.8MPa (120kgf/cm ²)	

• Measurement procedure

1. Lower the boom to the lowest limit, and tilt down the bucket to the ground.
2. Set the parking brake switch to the "ON" position.
3. Stop the engine. Repeatedly depress and release the brake pedal to discharge accumulator pressure.
4. Attach the pressure gauge to the unloader valve.
5. Start the engine, and keep the engine speed at low idle speed.
6. Measure and record the time from the low pressure alarm is turned off (3.9 ± 0.3 (40 ± 3kgf/cm²)) till the pointer of the pressure gauge stops rising (11.8 ± 0.5 (120 ± 5kgf/cm²)).

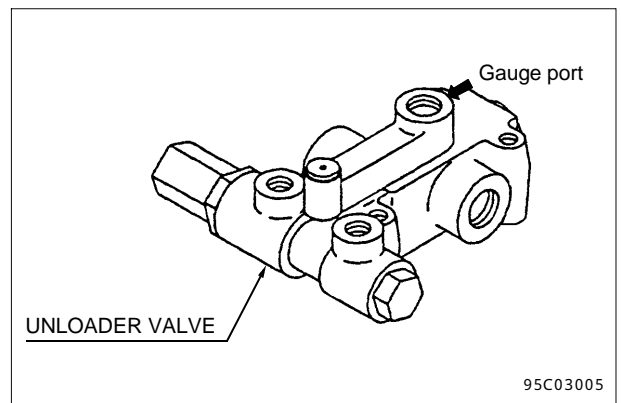

Pressure gauge port for measurement of unloader valve pressure

• Possible causes of extremely high measurement value and solution

The accumulator charging time is too long

Possible cause	Solution
Defective unloader valve	Disassembly & repair
Oil leakage from pipe	Check and repair
Defective pilot pump	Disassembly & repair

Safety Symbols

An accident may occur if you disregard safety rules.

In this manual, several expressions are used according to levels of danger for inspection and repair work as shown below. Read the work procedures and cautions described in this manual, and take preventive measures against possible problems before starting service work.



DANGER

This danger symbol identifies special warnings or procedures which, if not strictly observed, will result in death or serious injury.



WARNING

This warning symbol identifies special warnings or procedures which, if not strictly observed, could result in death or serious injury.



CAUTION

This caution symbol identifies special instructions or procedures which, if not strictly observed, may result in minor or moderate injury.

IMPORTANT

This important symbol identifies special instructions or procedures which, if not correctly followed, may result in serious machine damage.

We cannot predict all possible accidents or incidents that may occur during service work. Therefore, an accident that is not specifically mentioned in this manual may occur. To protect yourself from all accidents, be careful when doing service work.

Applying and Storing Articulation Stopper

1. Applying articulation stopper

WARNING

Unexpected movement of the machine could cause serious injury or death. There is a possibility that a service man may be crushed in the articulation area if the machine unexpectedly turns during repair work. To prevent such an accident, be sure to apply the articulation stopper before starting work.

1) Park the machine so that the frame is straight ahead. Remove the pin (1) from the articulation stopper on the rear chassis.

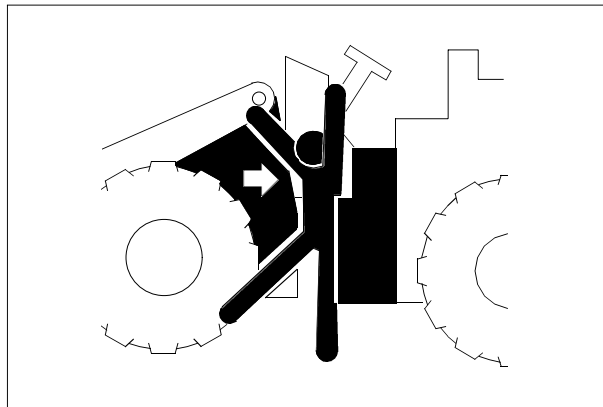

2) Turn rod (2) (articulation stopper) to the front and then align the pin hole. Insert the pin (1) into the rod to lock the front chassis to the rear chassis.

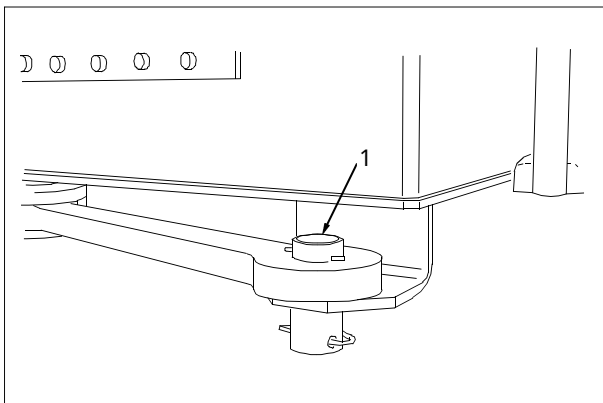

WARNING

To align the pin with the pin hole, start the engine and slightly turn the steering wheel. Be careful! Your body or finger may be crushed in the machine when the machine turns.

Stay out of the articulation area while aligning the holes.

When inspecting or servicing machine in articulation area, do not start the engine without applying the articulation stopper and place "DO NOT START" or "DO NOT OPERATE" tag on steering wheel.

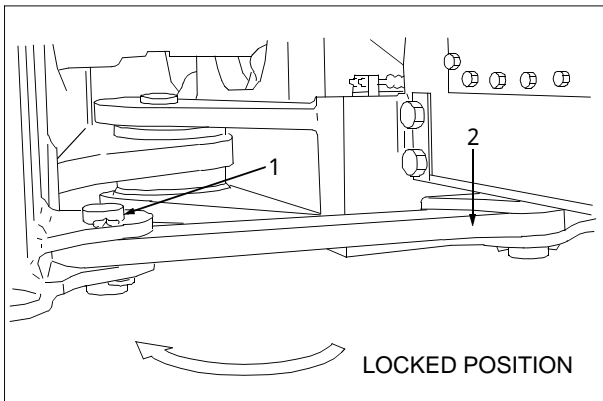

2. Storing articulation stopper

Store the rod (2) and pin (1) as shown.

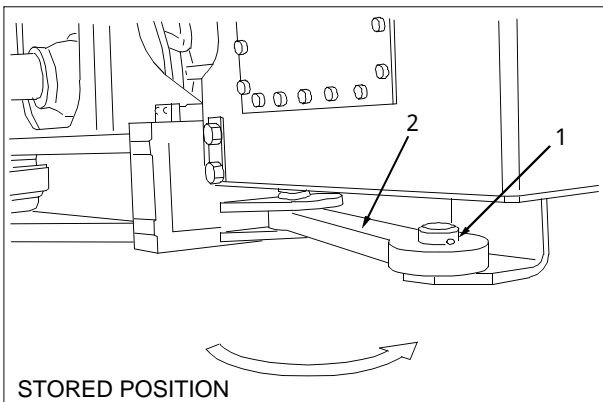

Cab

Removing and Reinstalling Cab

1. Removing Cab

WARNING

Unexpected movement of the machine could cause an accident resulting in injury or death.

- Position the machine on level ground, and block the tires with chocks, etc. to prevent them from moving.
- Lower the bucket onto the ground, and apply the parking brake.
- Remove the engine key, and hang a "DO NOT START ENGINE!" tag on the steering wheel.

Before starting work:

- Remove the ROPS.
- Remove the deck both right and left side.

1) The cover (1) for the outer filter is located at the right rear side of the cab.

Turn the rings counterclockwise and then remove the cover (1).

Remove the outer filter (2) from the cab.

Note: When installing the outer filter into the cab, be sure to align the air flow arrow on the outer filter to point toward the cab.

2) Remove the cover (3).

3) Disconnect the vinyl tube (4) for window washer liquid.

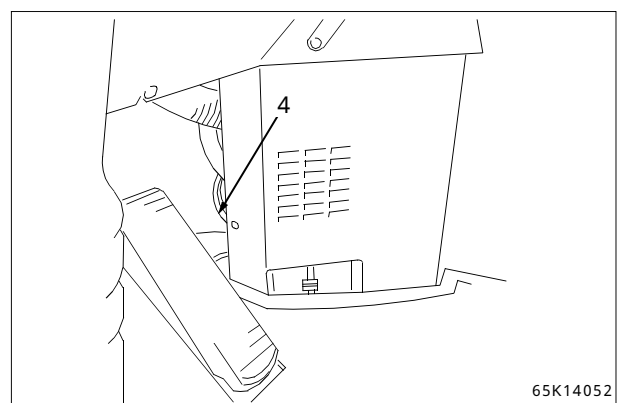
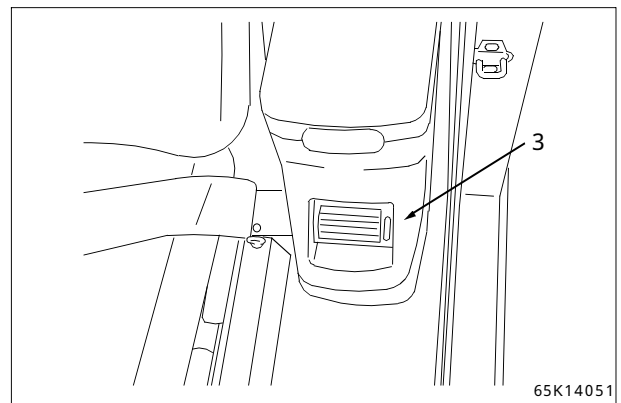
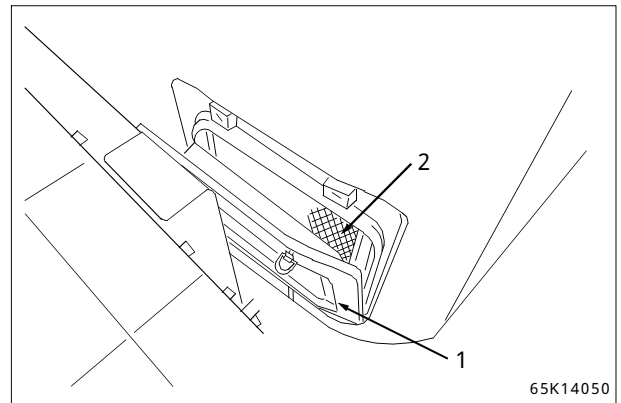

5) Screw the M12 (P1.75) bolt of approximately 70mm length into the center of the bushing (5) to push out the bushing. This bolt is used as a jack screw.

Remover bolt : M12(P1.75), totally threaded

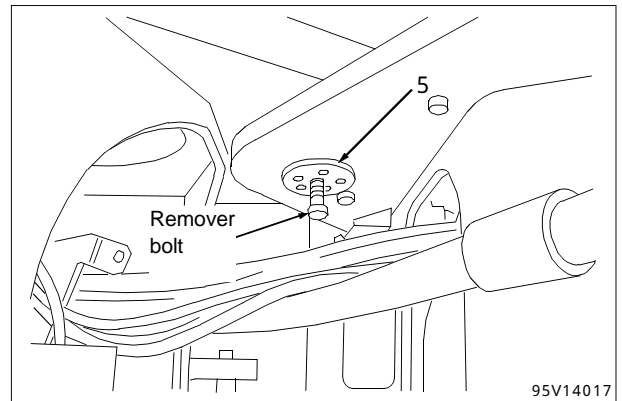
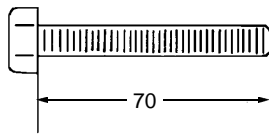

95V14017

6) Before disconnecting the front chassis (6) from the rear chassis (7), be sure to support the front chassis using the jack and blocks so that the front chassis will not fall backward. Before disconnecting the front chassis from the rear chassis, be sure to sling the rear chassis using a crane (apply the rope to the hook (8)) so that the rear chassis will not fall backward.

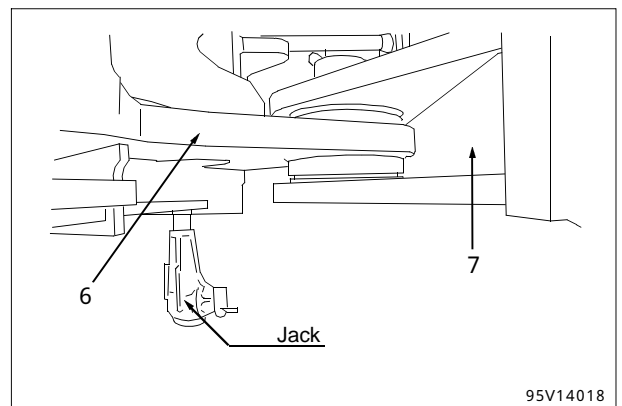

95V14018

WARNING

When using a crane, insufficient signal and sling could cause an accident resulting in injury or death. To prevent such an accident, observe the following items :

- Check a sling before using and do not use improper sling.
- Use signals as agreed upon before starting work.
- Stay out of the working area while using a crane.

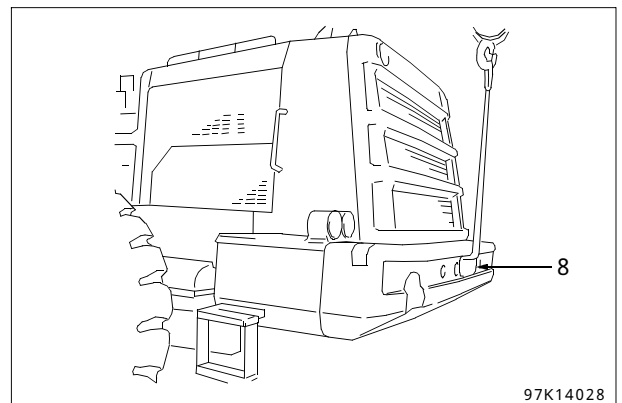

97K14028

7) Push the upper center pin out using a jack.

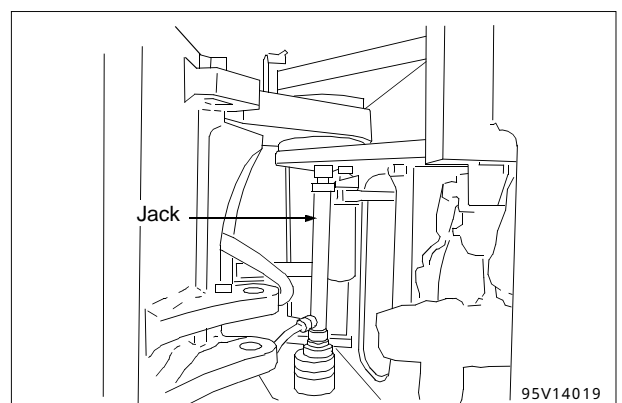

95V14019

Bucket positioner adjustable angle

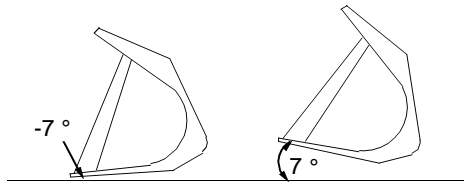

Boom kick-out adjustable angle

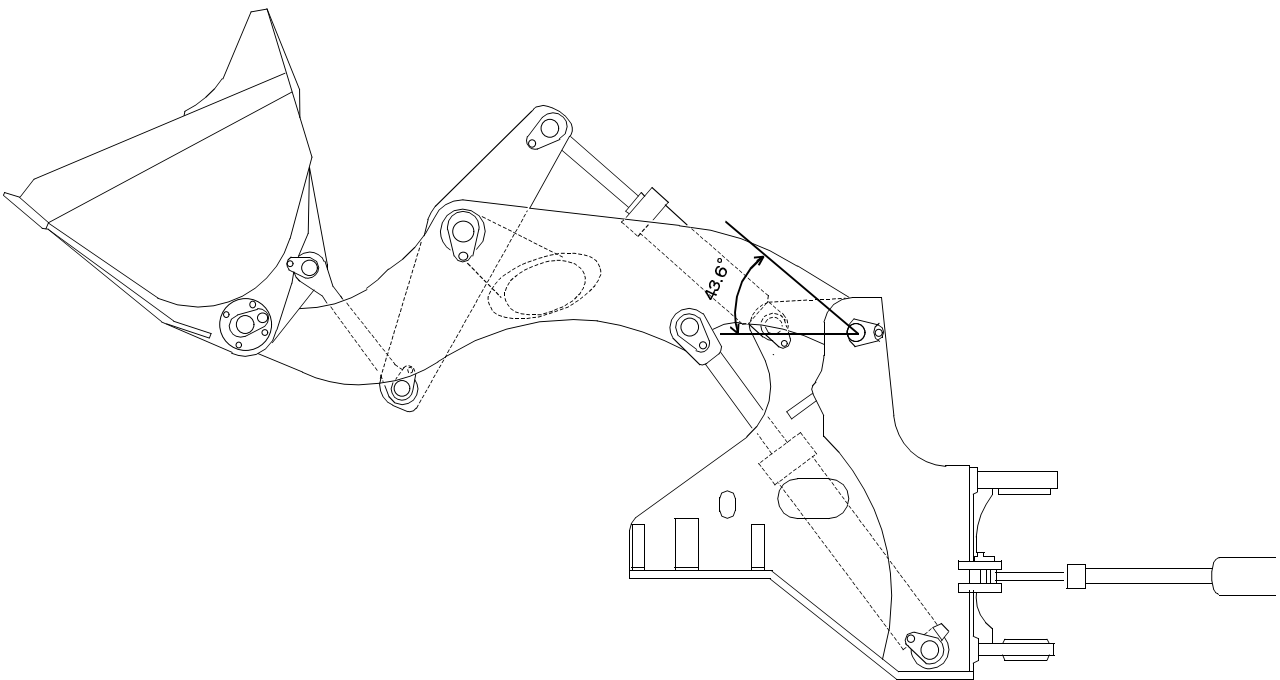

95Z 1403

4) While supporting the air cleaner case (11) with your hand, remove the band retainer nuts (12), and then lower the air cleaner case.

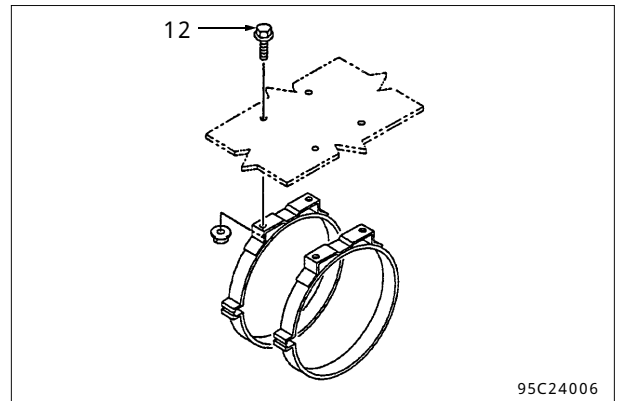

5) Take out the air cleaner case (11) from the opening.

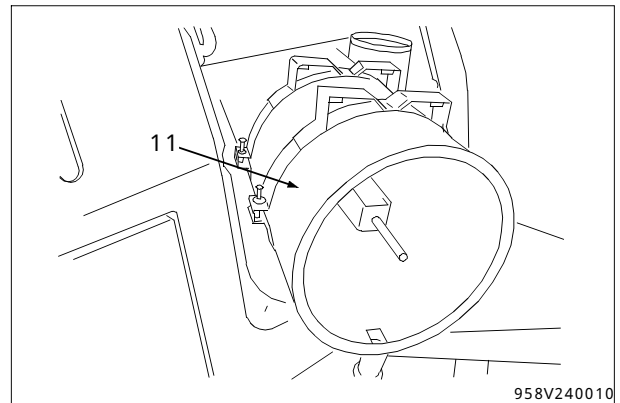

2.Reinstalling propeller shaft

For reinstallation, follow the above procedure in the reversed direction.

Note: If the bands of the air duct are not properly positioned or tightened, the duct will draw in dust that will cause an engine problem. Carefully reinstall the air duct.

3) Temporarily sling the axle assembly (6), and then remove twelve retainer bolts (7).

Place the axle assembly (6) on a carrier to smoothly pull out.

 : Axle assembly : 2,010kg

Torque for assembly:

 : Retainer bolt : 1373N-m (140.0kgf-m)

Note: During reassembly be sure both mating surfaces are clean and free of paint.

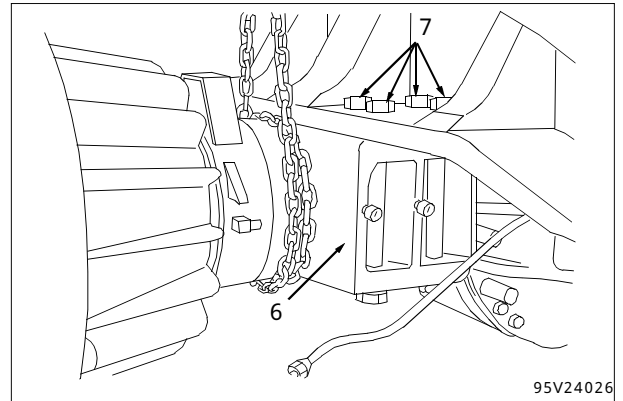

95V24026

2.Reinstalling front axle assembly

For reinstallation, follow the above procedure in the reversed direction.

After reinstallation, completely bleed air in the auto adjuster valve first and then the service brake.

CAUTION

Before air bleeding in the brake oil line, be sure that the wheel and tire assemblies are installed on the wheel hub. If fail to do, the bolts (4 pcs) temporarily tighten the spider and the wheel hub may be broken by the brake piston. Finally the spider and the cover may fall off.

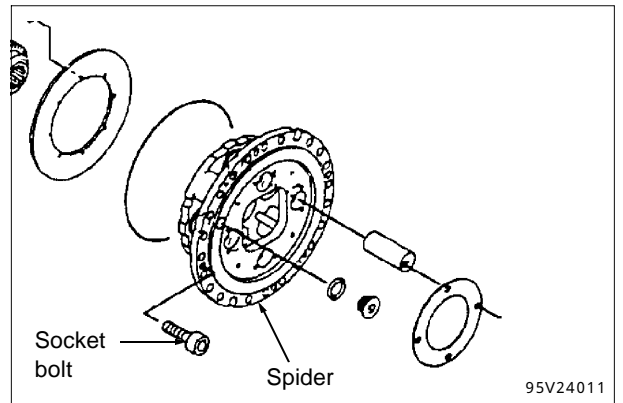

95V24011

Reference

Air bleeding procedure

Connect a vinyl tube to the air bleeder nipple, and place an oil can to receive the oil.

Fill the brake oil tank. Slightly loosen the air bleeder nipple, and then press the brake pedal several times. When the oil flows from the air bleeder nipple, close the nipple.

After that, each time you press the pedal, open the air bleeder nipple to slightly discharge oil, and then immediately close the nipple. Repeat this until there is no air in the oil. When the oil level in the reservoir lowers, add oil to the tank.

Completely bleed each wheel of air.

2.Reassembling front axle

IMPORTANT

- Replace all the O-rings and seals with new ones.
- Clean and check all the parts. If a part is damaged, replace it.

To reassemble the front axle, follow the above procedure in the reversed direction.

3.Cautions for reassembling floating seal

Floating seal location

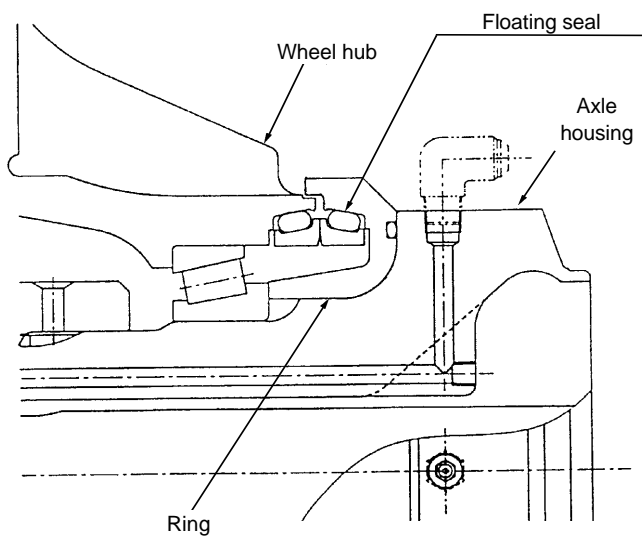

Seal cross section

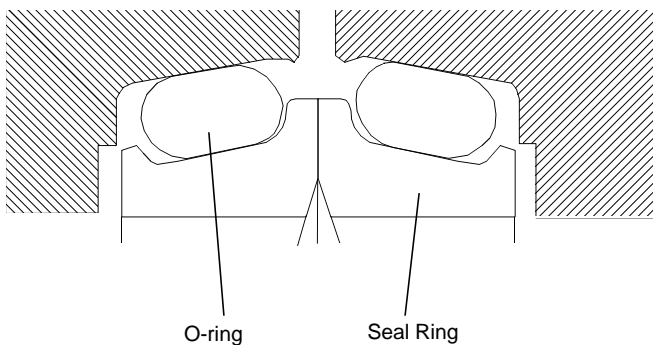

Note : The rotating ring and the fixing ring are exactly the same. They can be used both ways.

Assembling procedure

1. Checking before seal installation

(1)Checking seal

- Check the seal ring for distortion and scratches.
- Check the O-ring for scratches.

(2)Check the wheel hub and the ring for bur. If any remove it by sand paper etc.

(3)Clean the seal installation part on the wheel hub and the seal ring, and remove oil on them.

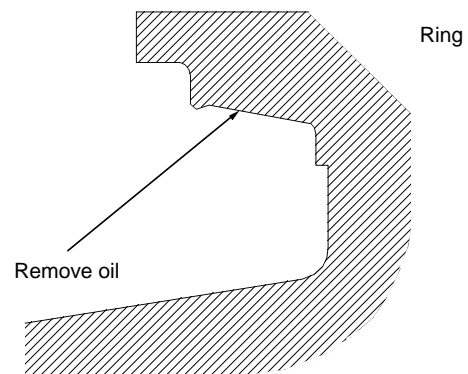

Put thin gear oil (Do not use grease)

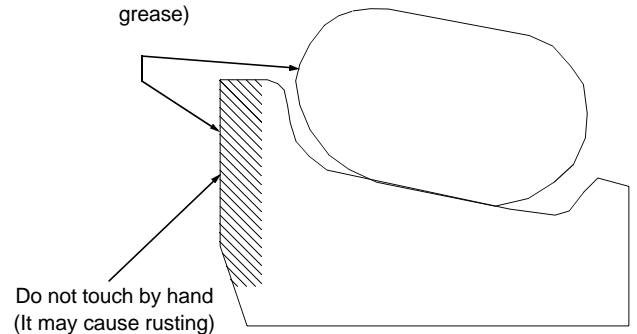

2. Assembling procedure

(1)In case no jig is used

- Install the O-ring on the seal ring.
- Put thin gear oil on the O-ring.
- Insert the floating seal into the ring and the wheel hub pushing the O-ring by fingers. (Make sub-assembly)
- Check if the seal ring is correctly positioned or the O-ring is not twisted.
- Clean the surface and put thin gear oil on it.
- Install the ring and the wheel hub to the axle housing.

Disassembling and Reassembling Internal Gear Hub

1. Disassembling internal gear hub

- 1) Turn up the internal gear hub (1), and then remove the two O-rings (2).

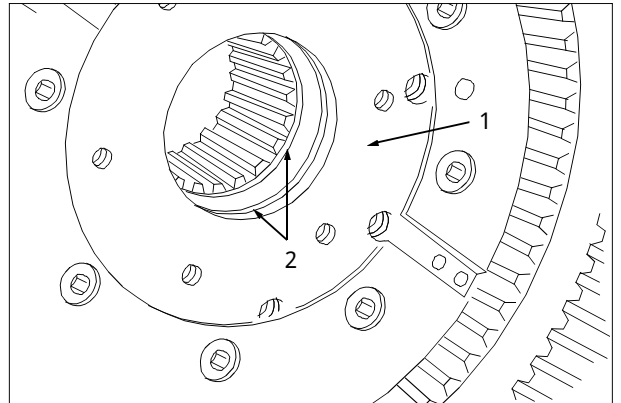

- 2) Remove the taper roller bearing (3).

Removal method: Unless the taper roller bearing is removed the return spring for the brake piston does not come out.
For easy removal, heat the inner race using a gas burner with slow flame.

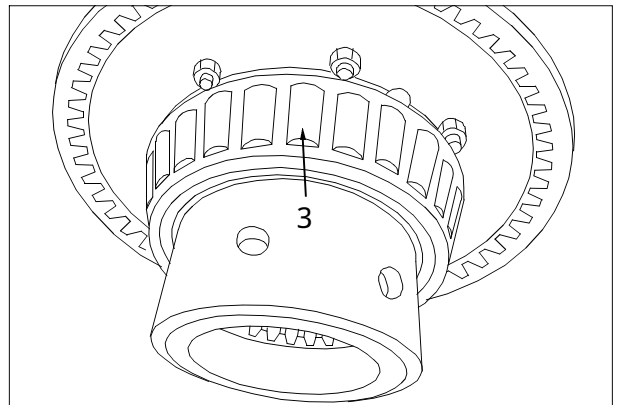

- 3) Remove twelve bolts (5) from the brake piston (4).

Torque for assembly:

 : Locknut : 34N-m (3.5kgf-m)

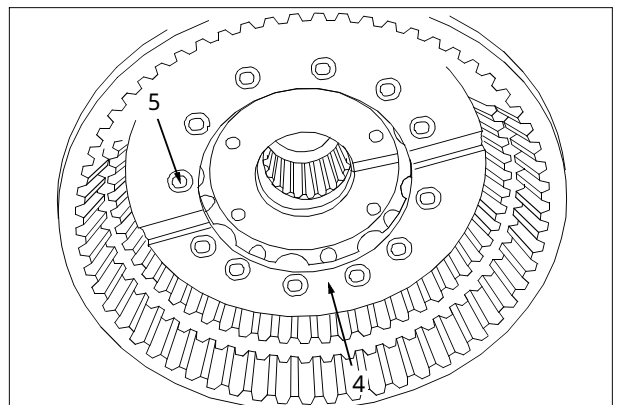

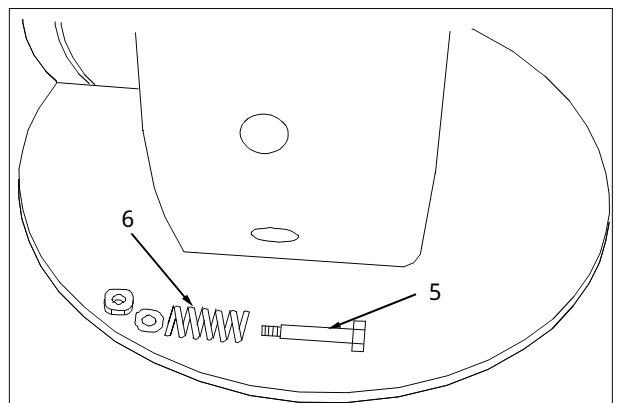

- 4) Remove the return spring (6).



4) Put a matchmark on the alignment point of the differential cage (1). Remove the bolts (2), and then separate the differential cage.

Torque for assembly:

 : Retainer bolt : 216N-m (22.0kgf-m)

 : Screw lock agent
(Three Bond 1327) application

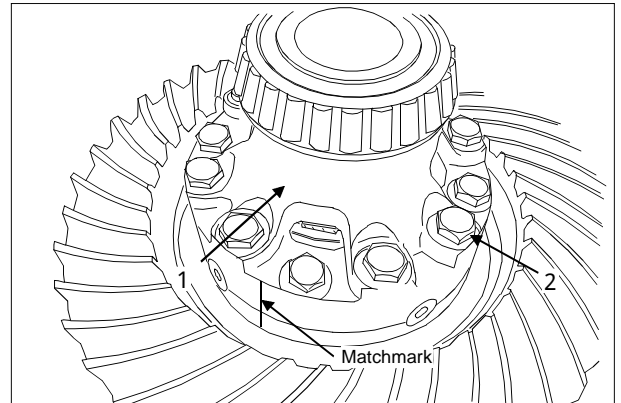

5) Remove the bushing (3) and the side gear (4).

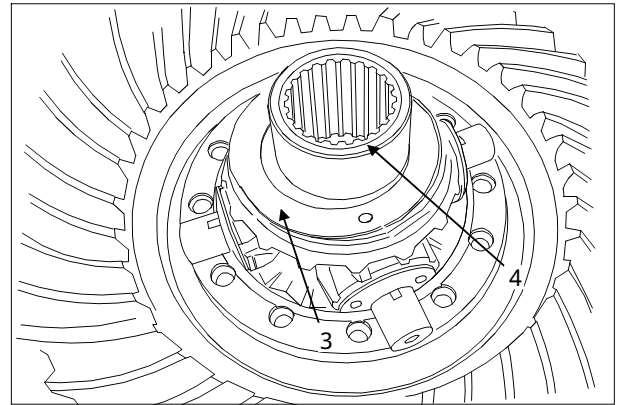

6) Remove the spider (5) with the pinion gears (6) and the thrust washers (7) as a unit.

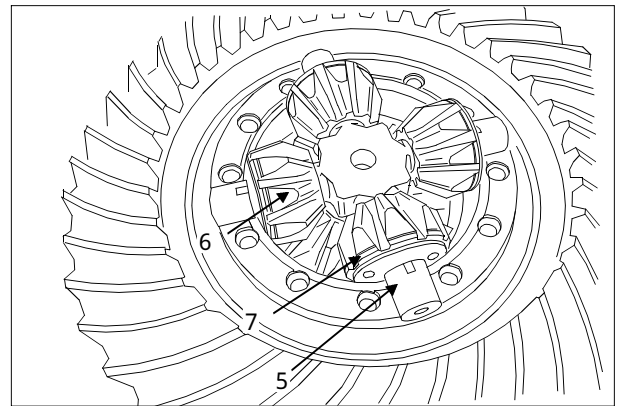

7) Remove the side gear (8).

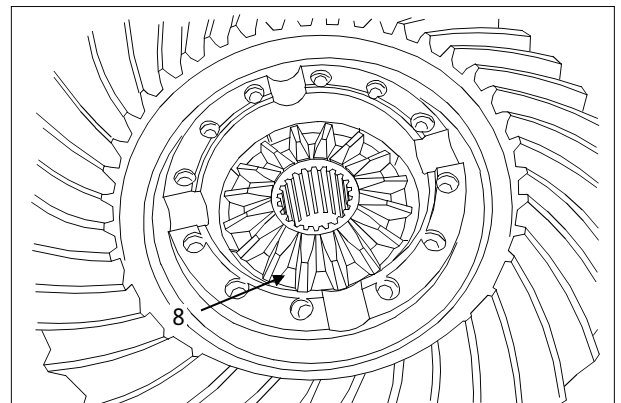

Axle Service Standard

Axle group

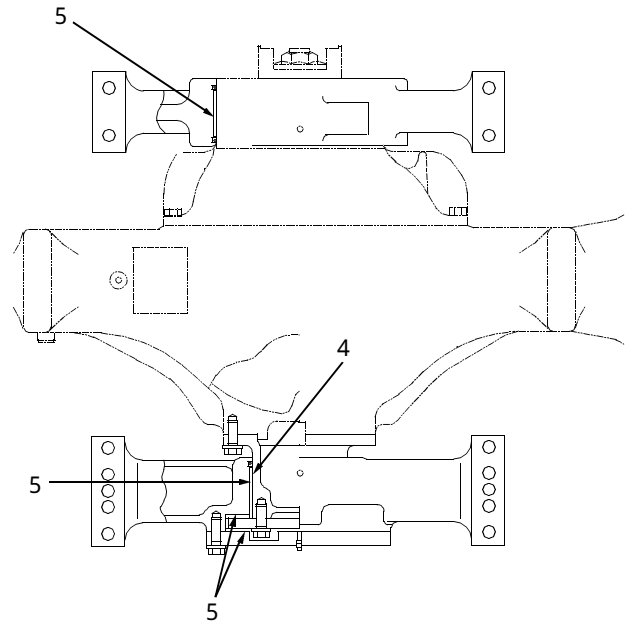
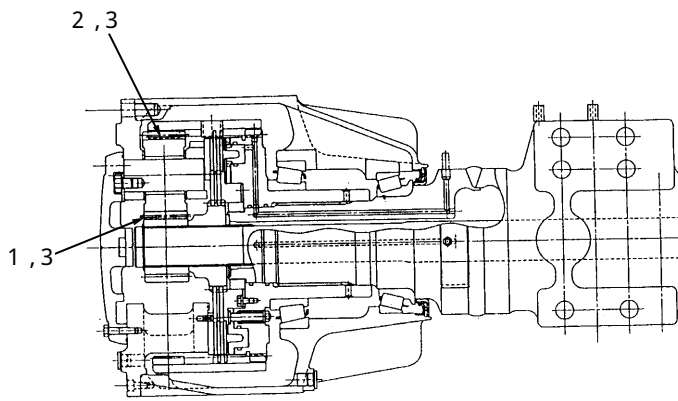

mm

No.	Item	Judgment standard		Solution
		Standard dimension	Tolerance	
1	Backlash between sun gear and planetary gear	0.188 ~ 0.662		Replacement
2	Backlash between planetary gear and internal gear	0.17 ~ 0.89		Replacement
3	Tooth contact of gear	No abnormality		Replacement
4	Axle support wear	Dia.: 1.0 / Radius: 0.5 (stepped)		Replacement
5	Bushing and wear ring wear	No oil groove		Replacement

CUSTOMER: _____ DEALER: _____
 DEALER LOCATION: _____ MACHINE LOCATION: _____
 TIRE SIZE: _____ BRAND & SPECIFICATION OF OIL: _____ AMBIENT TEMP: _____
 COMPONENT TYPE & MODEL NO. : _____ COMPONENT SERIAL NO. : _____

CHECKLIST TO BE COMPLETED BEFORE START-UP

- TRANSMISSION COOLER CLEANED TRANSMISSION PIPING CLEANED
 IN-LINE PRESSURE FILTER REPLACED TRANSMISSION LINKAGE CHECKED

*** ALL DATA TO BE RECORDED AT OPERATING TEMPERATURE. IF INITIAL TEST DATA IS INCORRECT, THEN CORRECT AND RETEST.**

TEST TO BE PERFORMED	INITIAL TEST	RETEST
HIGH IDLE RPM		
LOW IDLE RPM		
T/C STALL RPM		
HYDRAULIC STALL RPM		
FULL STALL RPM		
CREEP WITH BRAKE (F1) RPM		
CREEP WITH BRAKE (R2) RPM		

CLUTCH PRESSURE AT IDLE

F1	kg/cm ²	N1	kg/cm ²	R1	kg/cm ²
F2	kg/cm ²	N2	kg/cm ²	R2	kg/cm ²
F3	kg/cm ²	N3	kg/cm ²	R3	kg/cm ²
F4	kg/cm ²	N4	kg/cm ²	R4	kg/cm ²

CLUTCH PRESSURE AT HIGH IDLE

F1	kg/cm ²	N1	kg/cm ²	R1	kg/cm ²
F2	kg/cm ²	N2	kg/cm ²	R2	kg/cm ²
F3	kg/cm ²	N3	kg/cm ²	R3	kg/cm ²
F4	kg/cm ²	N4	kg/cm ²	R4	kg/cm ²

COMMENTS: _____

 Serviceman's Signature

KAWASAKI HEAVY INDUSTRIES, LTD.
 CONSTRUCTION MACHINERY DIVISION

Copy as required

5) Remove the bolts (6) to remove the torque converter housing.

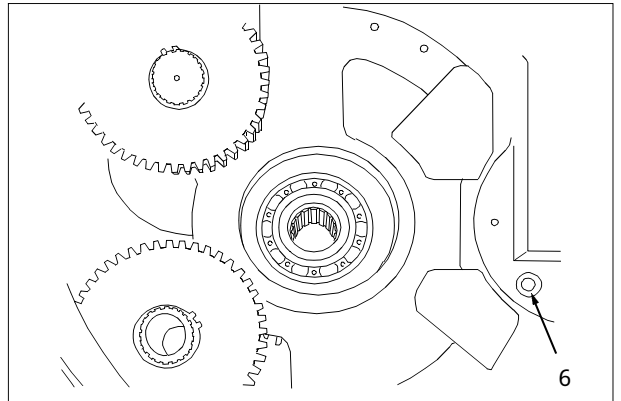

6) Remove four bolts (7).

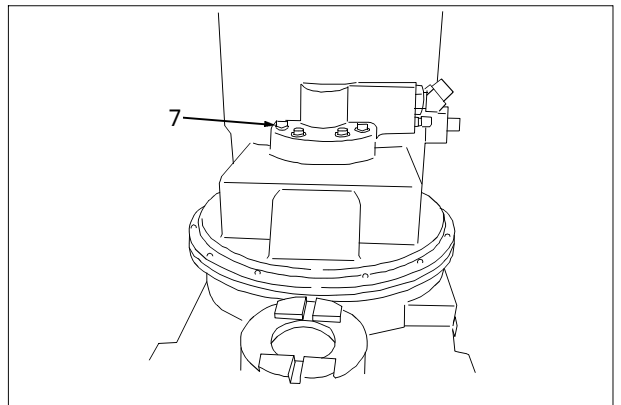

7) Remove twelve bolts (8) of the torque converter housing and the transmission.

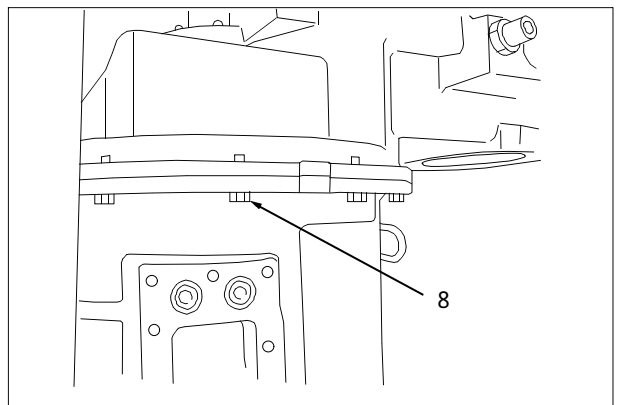

8) Remove four sleeves (9).

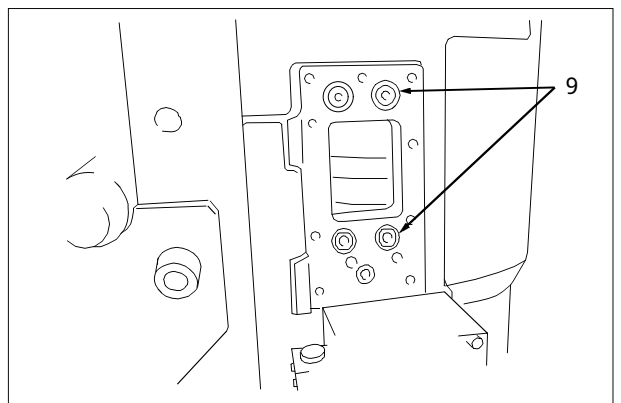

Clutch Assembly

Disassembling and Reassembling Clutch Assembly

1. Disassembling clutch assembly

Before starting work:

- Remove the clutch assembly from the transmission housing, and set it on the work bench.

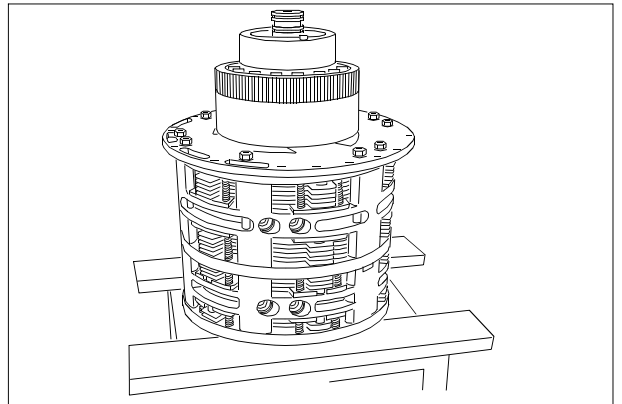

1) Remove the snap ring (1).

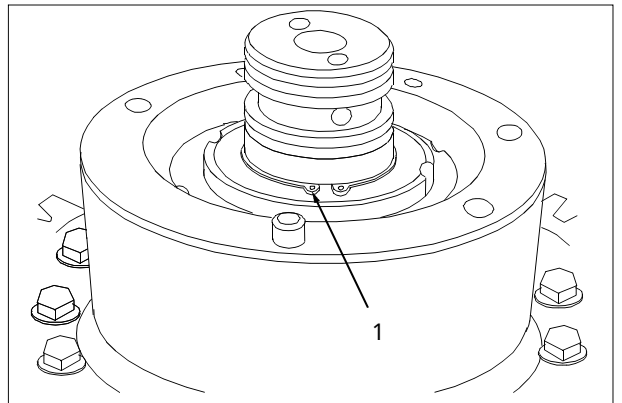

2) Lift and remove the high clutch assembly (2).

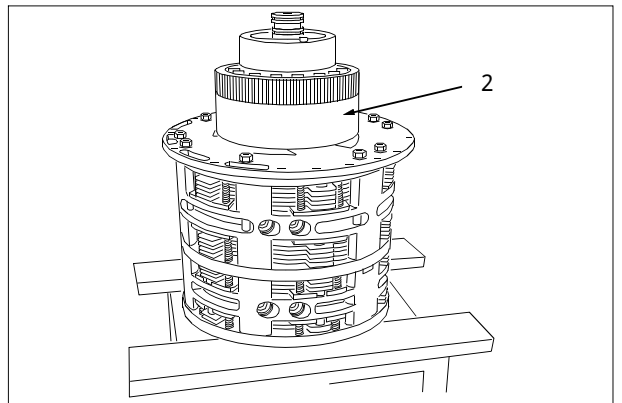

3) Remove the snap ring (3).

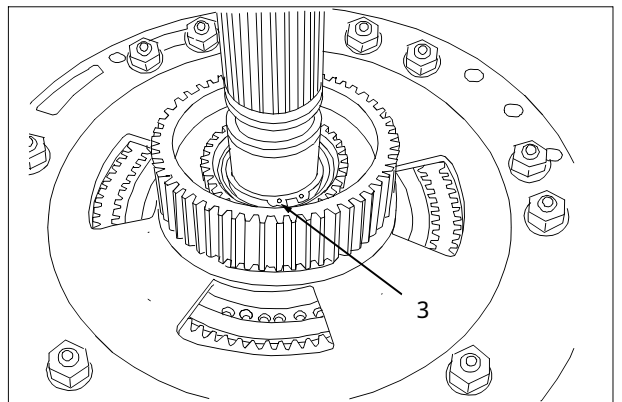

13) Install the ring gear (22) with addendum notch up.

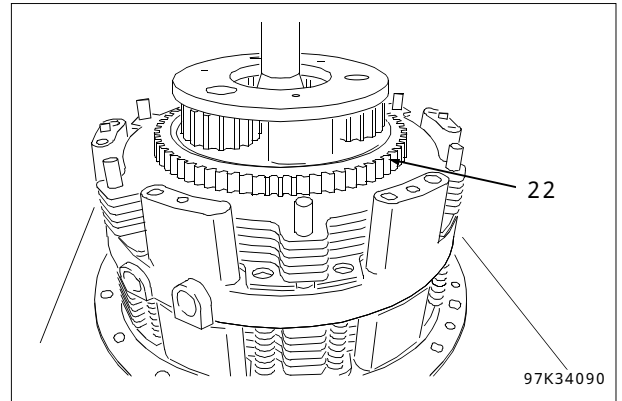

14) Install one remaining friction plate and one steel plate. After that, install six springs (23).

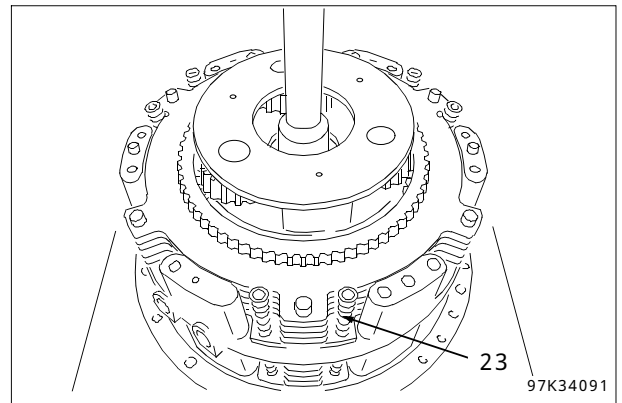

15) After putting the housing (24) temporarily, turn the spring with hands check that it is fitted properly in upper/lower spring holes. Tighten two housing connecting bolts (25) located at diagonal position.

 : Bolt (25) : 90N-m (9.15kgf-m)

 : With lubrication oil (Engine oil or gear oil)

Note: When installing the housing, be careful for two alignment dowel pins.

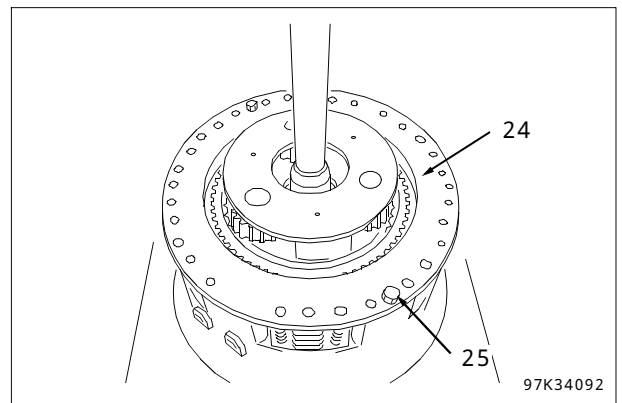

16) Apply the air pressure of 0.6MPa (6kgf/cm²) through the oil hole to check for piston operation and air leakage.

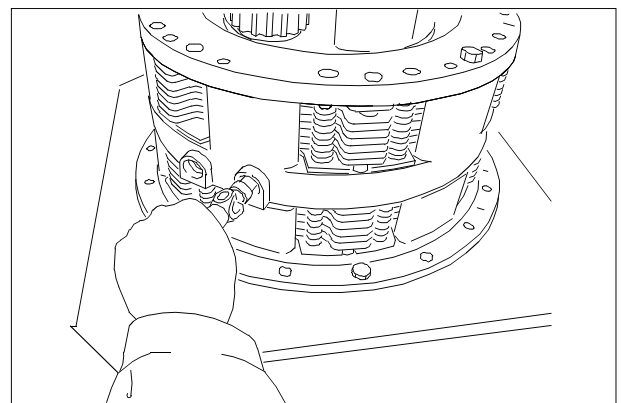

Reverse Clutch Spider

Disassembling and Reassembling Reverse Clutch Spider

1. Disassembling reverse clutch spider

- 1) Remove the snap ring (1) to separate the spider (2) and the clutch drum (3).

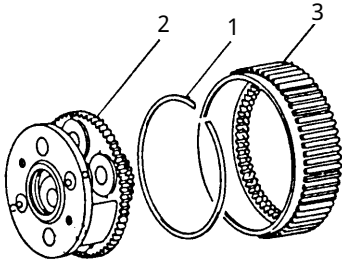

97ZA3434

- 2) Drive the spring pin (5) that locks the pin (4) all the way into the pin, then remove the pin (4), washers (6), planetary gear (7) and the needle bearing (8).

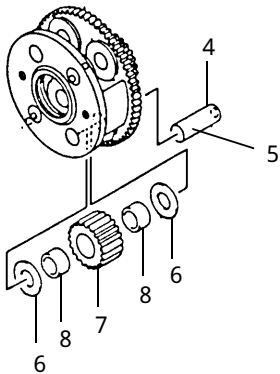

115ZA3425

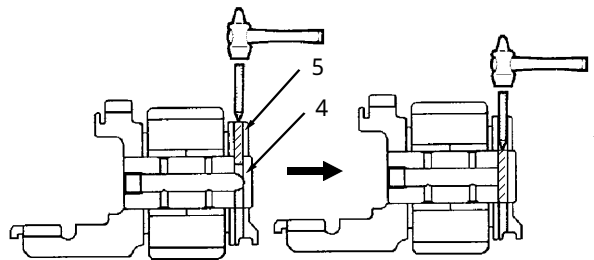

7) Install three friction plates (12) and two steel plates (13) alternately after the piston.

Note: Be sure that the friction plate comes after piston.

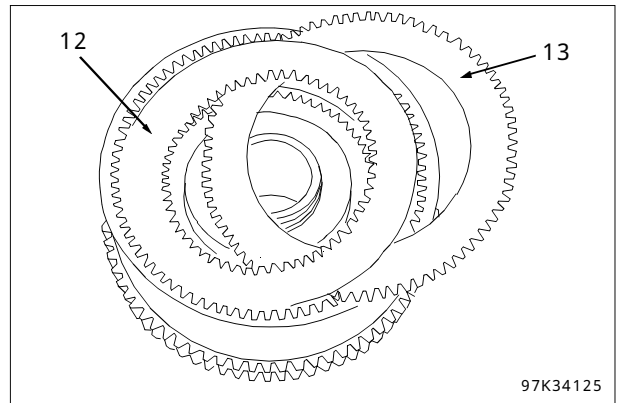

8) Install the pressure plates (14) and then install the snap ring (15).

9) Measure piston stroke.
Standard piston stroke : $2.5 \pm 0.5\text{mm}$

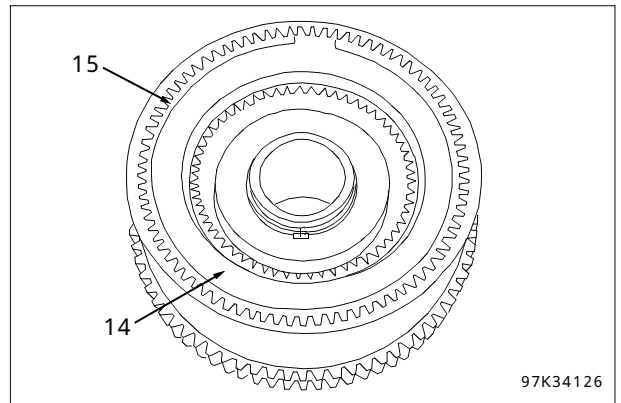

10) Invert the clutch assembly (16) and install the sleeve (17).

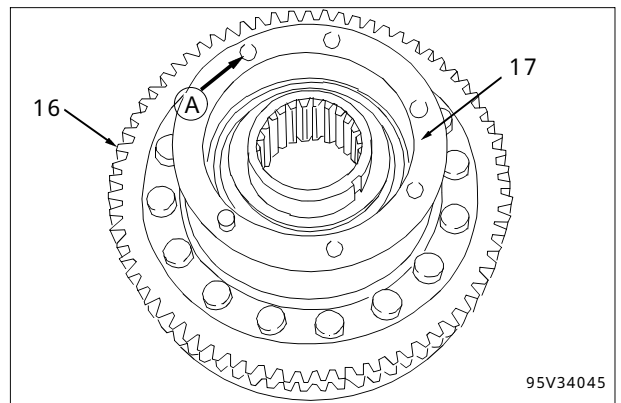

11) Install the bearing nut (18).

 : Tighten the bearing nut so as to the pre-load at the point (A) is between 113 and 137N (11.5 ~ 14.0kgf).

12) After confirming the pre-load, calk the bearing nut (18) to lock it.

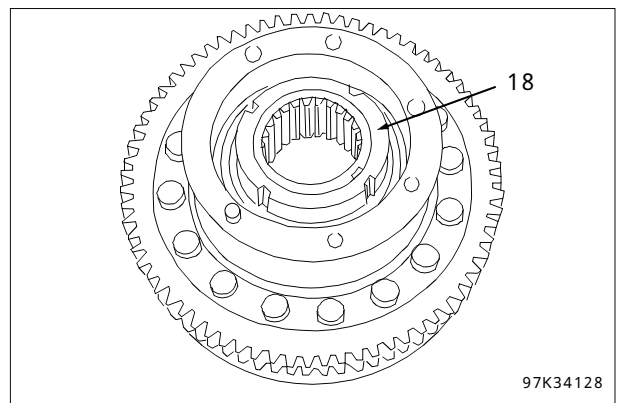
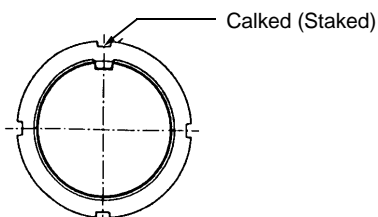

HYDRAULIC GROUP

44

Hydraulic Pump	44-2
Steering Pilot Valve	44-5
Steering Valve	44-16
Stop Valve	44-24
Multiple Control Valve	44-28
Boom Cylinder	44-35
Bucket Cylinder	44-38
Steering Cylinder	44-42
Hydraulic Cylinder	44-45
Pilot Valve	44-51
Pilot Relief Valve Unit	44-59

11) Remove the O-ring (22) from the housing.

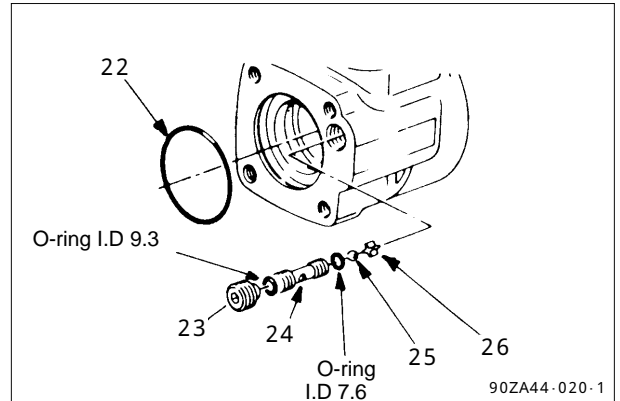

(Disassembling emergency check valve)

Note: Liquid adhesive is applied to the set screw.

12) Remove the set screw (23) from the housing.

13) Pull out the check valve (24) with the puller (B).

14) Tap gently on the housing to take out the ball (25) and the retainer (26).

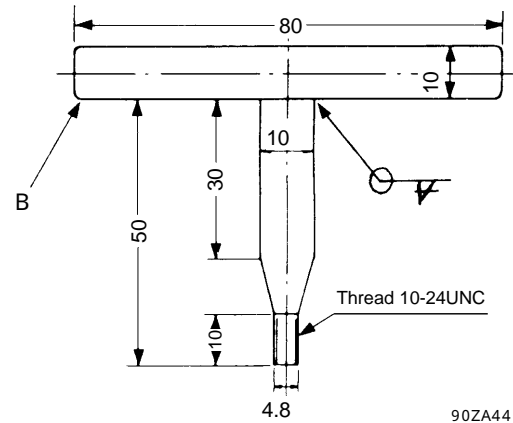

- 9) Remove the filter (10) at the bottom of the plug to prevent it from being lost, and remove the spring (11).

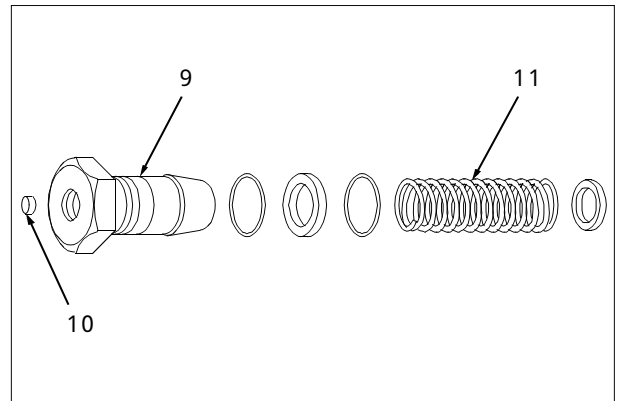

- 10) Remove the plug (12).

Torque for assembly:

 : Plug : 176N-m (18.0kgf-m)

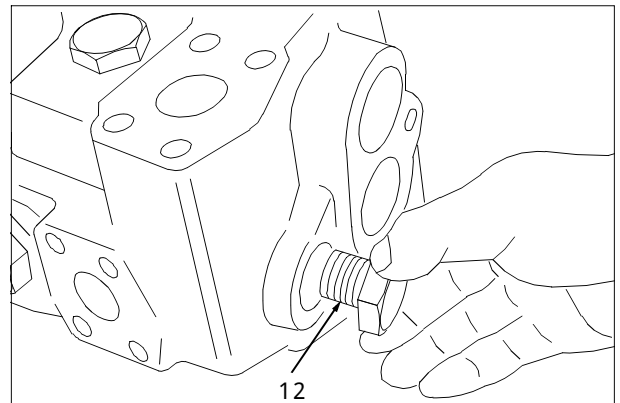

- 11) Slowly pull out the flow control plunger (13).

Note: Carefully pull out the plunger so that it is not forced out or distorted.

Handle the plunger with extreme care.

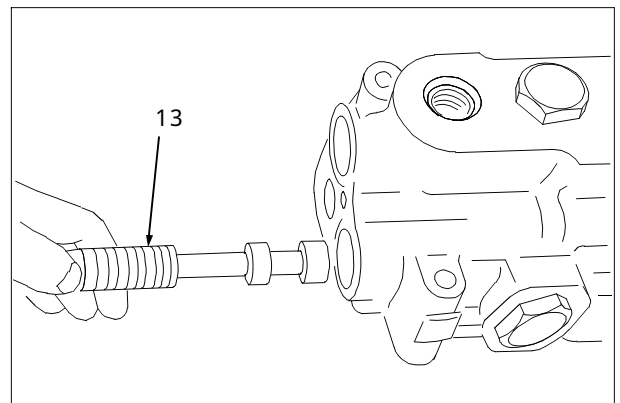

2.Reinstalling multiple control valve

To reinstall the multiple control valve, follow the above removal procedure in the reversed direction.

Cautions regarding reinstallation:

- a) Replace all the O-rings with new ones.
- b) Wash the multiple control valve mounting area.



WARNING

Unexpected movement of the machine could cause serious injury or death.

To prevent such an accident, be sure to stop the engine before you start working under the machine. In addition, block the tires with chocks to prevent the wheels from moving. While working under the machine, carefully keep contact with the person in the cab by giving signals to each other.

- c) Attach the pressure gauge, and then start the engine. Measure the pressure, and adjust it to the specified value. For a detailed description of pressure adjustment, refer to the Section 03.
- d) Operate the bucket and the boom, and check that they operate correctly.
- e) Check each section for oil leakage.
- f) Add hydraulic oil to the tank until the oil level rises to the specified point.

2.Reinstalling bucket cylinder

To reinstall the bucket cylinder, follow the above removal procedure in the reversed direction.

Note: Be sure the pins accept grease after installation.

3.Cautions regarding reinstallation



WARNING

During service work, do not stand on the machine. Standing on tire, boom or linkage could cause accidents and serious injury or death. Use a step, ladder, or work platform and do not stand on the machine.

Bleed the cylinder of air.

IMPORTANT

After repairing or replacing a cylinder, be sure to bleed the cylinder of air, or the piston seal or back-up ring may be seized.

Air bleeding procedure

a) While operating the engine at low-idling speed, operate the cylinder piston for 4 to 5 strokes.

Note: Stop the piston about 100mm before both stroke ends.

b) After that, operate the cylinder piston to both stroke ends for 4 to 5 times.

c) Add hydraulic oil to the tank, and check the cylinder for oil leakage.

Adjust the bucket positioner so that the clearance between the switch and the rod is 5 ± 2 mm .

Pilot Valve

For bucket control

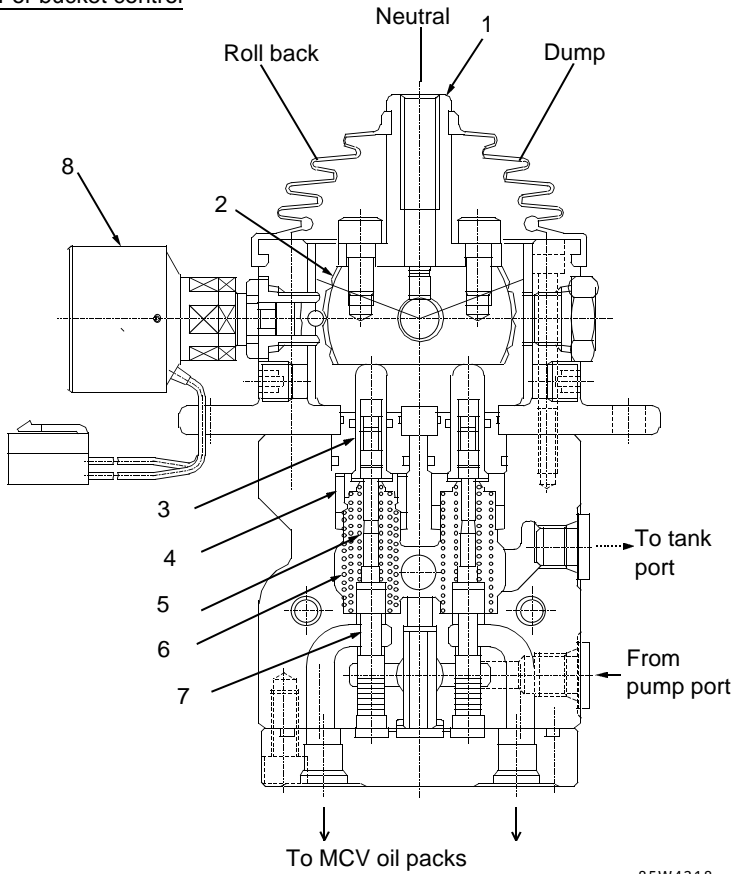

85W4218

For bucket control For boom control

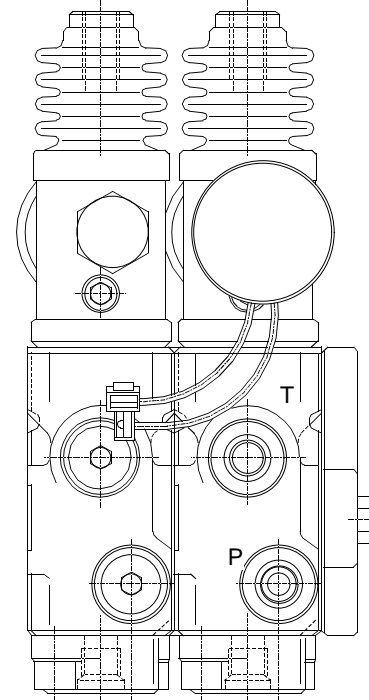

85W4211

View from the rear

For boom control

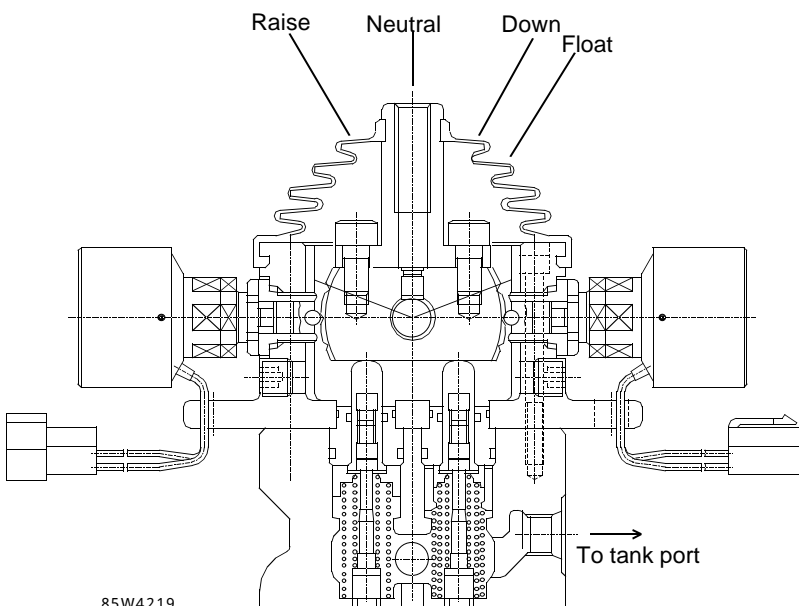

85W4219

1. Lever
2. Disc
3. Push rod
4. Spring seat
5. Spring for secondary pressure
6. Return spring
7. Spool
8. Detent magnet solenoid

HYDRAULIC GROUP

45

Steering Valve	45-2
Hydraulic Cylinder	45-3
Pilot Valve	45-4

Removing and Reinstalling Accumulator

1. Removing Accumulator

WARNING

Unexpected movement of the machine could cause serious injury or death. To prevent such an accident, observe the following items:

- Park the machine on level ground, and then block the tires with chocks to prevent wheels from moving.
- Use a stepladder or the like to reach a high position of the machine.

Before starting work:

- Stop the engine. Depress the brake pedal many times until there is no brake pressure.

- 1) Disconnect the hoses (1) from the accumulators (5), and then remove the bands (3) (4).
Remove the accumulators.

 : 147N-m (15.0kgf-m)

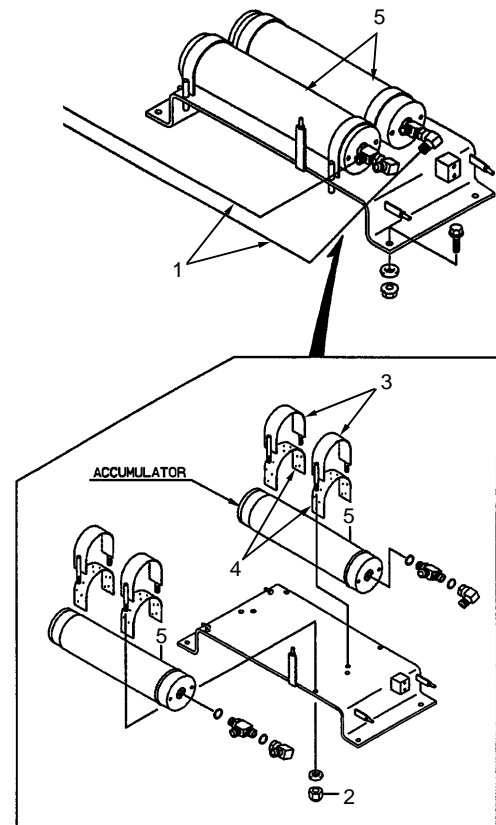

95C54005

2. Reinstalling accumulator

To reinstall the brake valve, follow the above removal procedure in the reversed direction.

Note: After reinstallation, check all the pipe-joints for oil leakage.

Tightening Torque

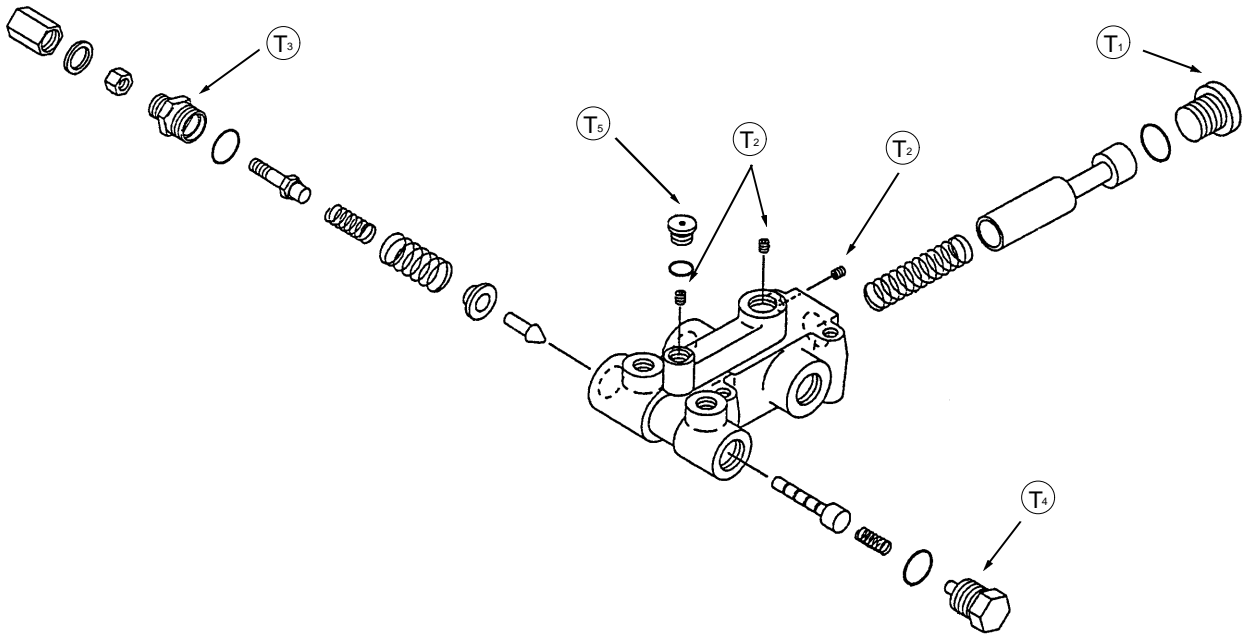

95C54006

:Tightening Torque

- T₁ : 118 ~ 137N-m (12 ~ 14kgf-m) width across flats : 12mm
- T₂ : 9.81 ~ 14.7N-m (1 ~ 1.5kgf-m) width across flats : 5mm
- T₃ : 98.1 ~ 118N-m (10 ~ 12kgf-m) width across flats : 36mm
- T₄ : 78.5 ~ 98.1N-m (8 ~ 10kgf-m) width across flats : 30mm
- T₅ : 29.4 ~ 39.2N-m (3 ~ 4kgf-m) width across flats : 6mm

Adjustment procedure of air cylinder linkage.**⚠ WARNING**

Unexpected movement of the machine could cause serious injury or death. To prevent such an accident, observe the following items:

- When removing the air cylinder, the machine may move. To prevent the machine from moving, park the machine on level ground, and lower the bucket onto the ground.
- In addition, block the tires with chocks to prevent wheels from moving.

- 1) Release parking brake (OFF).
- 2) Measure the dimension "A" if it is 87mm.
- 3) If not, remove pin (5), split pin (6), and washer (7) and loosen lock nut (2).
And adjust the linkage length by turning link (3) so that dimension "A" is 87mm.
- 4) Tighten lock nut (2) and reinstall pin (5), split pin (6) and washer (7).
- 5) Confirm the parking brake performance referring to Section 53.

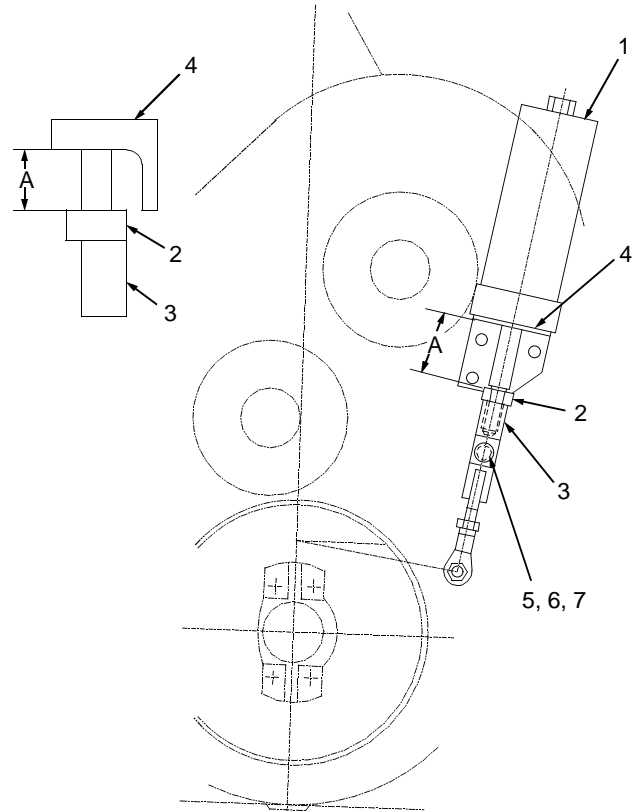

Parking brake "OFF" position.

1. Air cylinder
2. Lock nut
3. Link
4. Bracket
5. Pin
6. Split pin
7. Washer

1) Loosen the bolts (3) and slide the pins (4) back from center of brake head, and then remove the brake pad assemblies (5) from brake head.

2) Attach brake head to hydraulic pressure source. Restrain piston (10) opposite cap (8) with a C-clamp and apply hydraulic pressure until piston in inlet side is free of piston bore. Release pressure, disconnect brake head from pressure source and remove C-clamp.

3) Remove nut (13), washer (7) and press piston (10) from torque plate assembly (1) by pushing guide (19) towards center of brake head.

4) Remove bolts (6), washers (7) and cap (8) with attached guide (18). Remove packing (9) from cap (8).

Note: Do not remove guide (18) from cap (8) except to replace if damaged.

5) Remove packings (9), (20), boots (11) and bleeder screws (2) from torque plate assembly (1).

6) Replace all rubber parts (9), (11), (12), (20), (21), (22), using kits specified in applicable parts catalog.

7) Clean, degrease, repair or replace damaged or excessively worn parts, as required.

8) Inspect brake pad assemblies (5) for excessive wear. Replace if lining is worn to wear limit. Refer to Section 55 for the wear limit.

9) Inspect pistons (10) for minor scratches or nicks and blend with crocus cloth. Replace pistons that are badly nicked or scratched.

10) Pins (4) that are deeply grooved should be replaced or rotated so grooved surface is opposite brake pad assembly (5) ends.

11) Reassemble brake head in reverse sequence of disassembly noting the following.

12) Lubricate packings (9), (12), (20) and O.D. of pistons (10) with hydraulic fluid specified in applicable brake head parts catalog sheet, prior to installation.

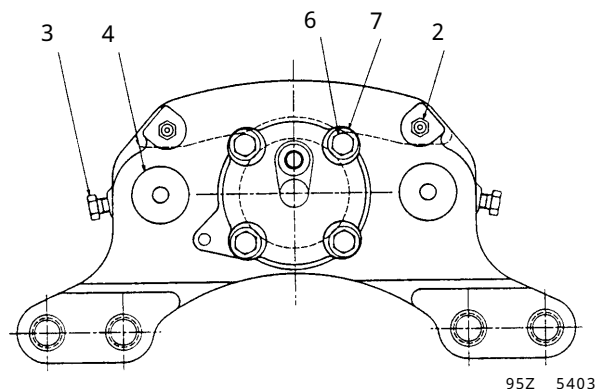

95Z 5403

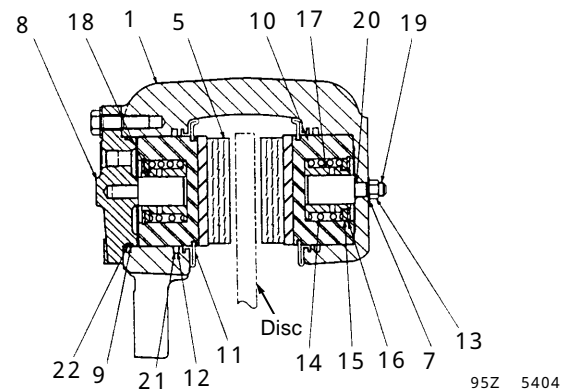

95Z 5404

Fuse

Removing and Reinstalling Fuse

1. Removing fuse from inside of control box.

CAUTION

Before removing a fuse, be sure to turn off the starter key.

1) Remove the cover (1) (2).

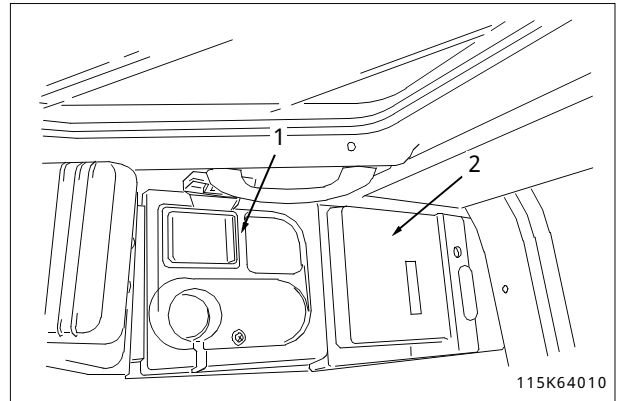

2) Remove the bolt (3).

IMPORTANT

- When replacing fuse, be sure to turn the starter switch to "OFF" position.
 - Using wrong capacity fuse or bypassing fuse can cause electrical system damage.
- Never replace fuses with higher amperage rating.

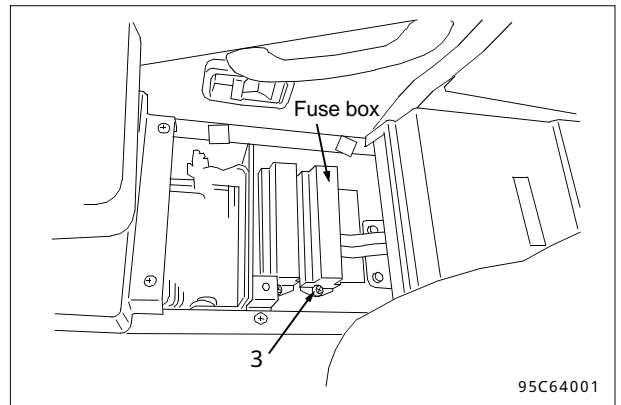

Fuse inside the control box

SPARE	5A	LIGHTING HEAD LIGHT	20A
SPARE	5A	R. WORK LIGHT	10A
R. WIPER	5A	BOOM KICKOUT BUCKET POSITIONER	10A
F. WIPER	10A	BACK LAMP STOP LAMP TURN SIGNAL	15A
SPARE	10A	PARKING BRAKE CONTROLLER	10A
F. WORK LIGHT	10A	BUZZER MONITOR	5A
SPARE	3A	COLD STARTER	15A
R. WORK LIGHT (CAB)	10A	SPARE	15A
SPARE	10A	SPARE	15A
SPARE	5A	4 WAY FLASHER HORN ROOM LAMP	15A
SPARE	5A	SPARE	15A
SPARE	5A	RADIO	5A
AIRCON (OPTION)	20A	FUEL VALVE	5A
AIRCON (OPTION)	20A	NEUTRAL RELAY	5A
AIRCON (OPTION)	20A	BATTERY RELAY	5A

Air Conditioner

1. Periodical Inspection/Serviceing

Inspection/maintenance item		Criteria	Action
Refrigerant	Charge quantity	Air bubbles should not be seen through sight glass.	Inspection/adjustment
Condenser	Blockage in fins	Blockage should not be detected.	Clean
Compressor	Operating status	Magnetic clutch should operate. Abnormal sounds should not be detected.	Inspection/adjustment/replacement
Belt tension pulley	Operating status	Abnormal sounds and backlash should not be detected.	Inspection/replacement
V belt	Damage and tension	Damages should not be detected. Tension should be proper.	Adjustment/replacement
Blower motor and fan	Operating status	Abnormal sounds or vibration should not be detected.	Inspection/replacement
Control mechanism	Operating status	Each part should operate in accordance with switch operations.	Inspection/replacement
Air filter for inside/outside air	Blockage	Air quantity should not be so small as to hinder air conditioning.	Cleaning/replacement
Each mounting area and piping	Looseness, gas leak and damages	Looseness, gas leak and damage should not be detected.	Tightening/charge

2. Tightening Torque

1) Tightening torque for hose and pipes

Connection type	Connection area	Pipe size or bolt size	Tightening torque N·m (kgf·m)
Nut type	Condenser-expansion valve	ø8 piping	15 (1.50)
	Compressor-condenser	D1/2 piping	25 (2.50)
	Evaporator-compressor	D5/8 piping	34 (3.50)
Block joint	Receiver	M6 bolt in receiver (4T)	7 (0.70)
	Evaporator-compressor	Any M6 bolt (6T) other than above	12 (1.20)

2) Tightening torque for screws and bolts in special control regions

Special control region	Bolt size	Tightening torque N·m (kgf·m)
Head bolt of magnetic clutch	M6	13 (1.35)
Mounting bolt for servo motor for inside/outside air selection	M5	0.5 (0.05)
Fixing nut of blower motor and condenser fan	M6	5 (0.55)
Fixing bolt of blower motor and condenser motor	M5	3 (0.30)

3 ENTRETIEN

L'entretien ou une réparation de la machine ne devra être effectué que par un personnel bien entraîné ou expérimenté.

Pour le montage et le démontage, effectuez ce travail en vous référant au manuel d'atelier (). Cependant, ce manuel d'atelier n'englobe pas les travaux de montage et de démontage de toutes les pièces. Pour les pièces qui ne sont pas décrites, effectuez votre travail en vous basant sur vos propres connaissances de base.

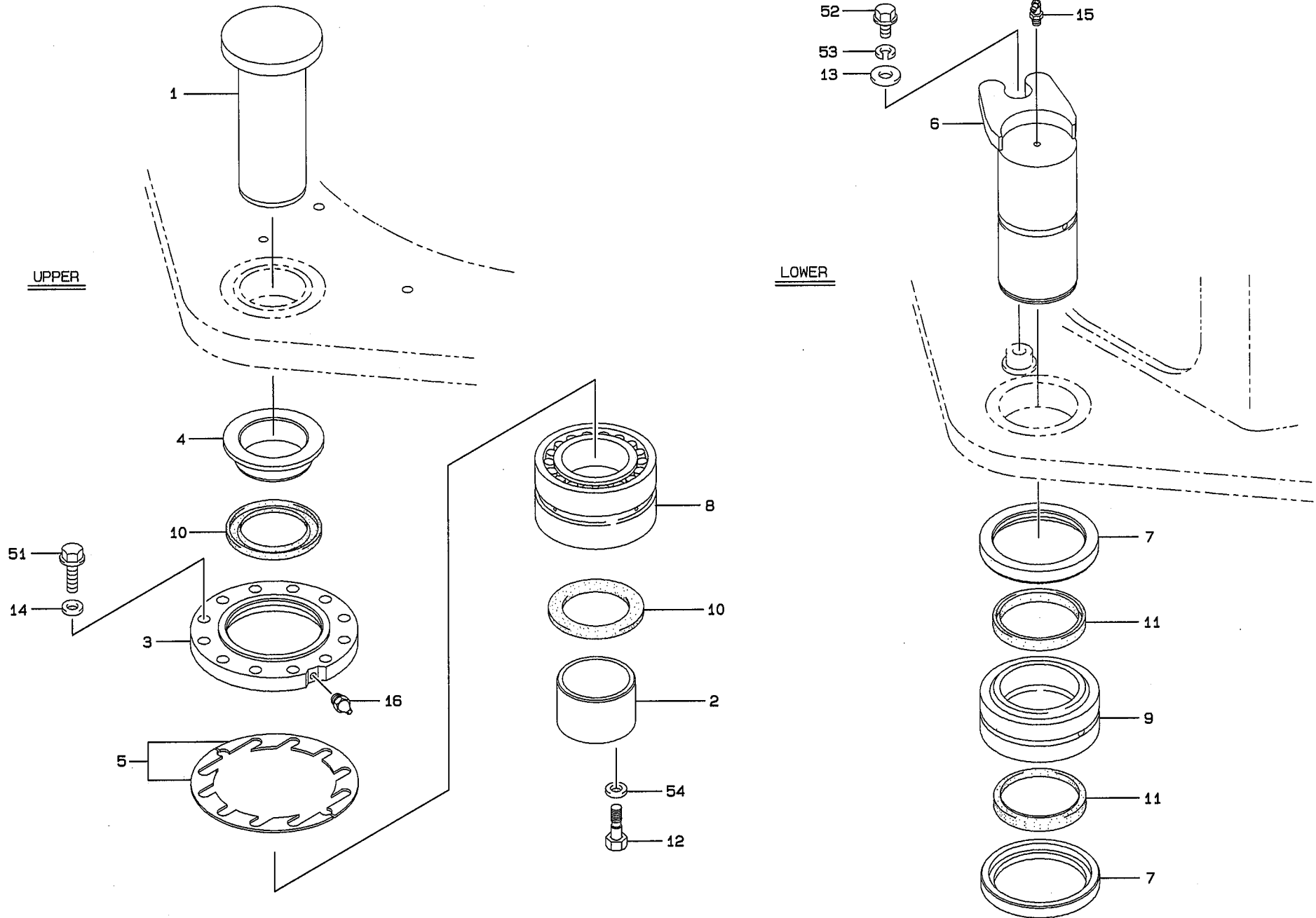

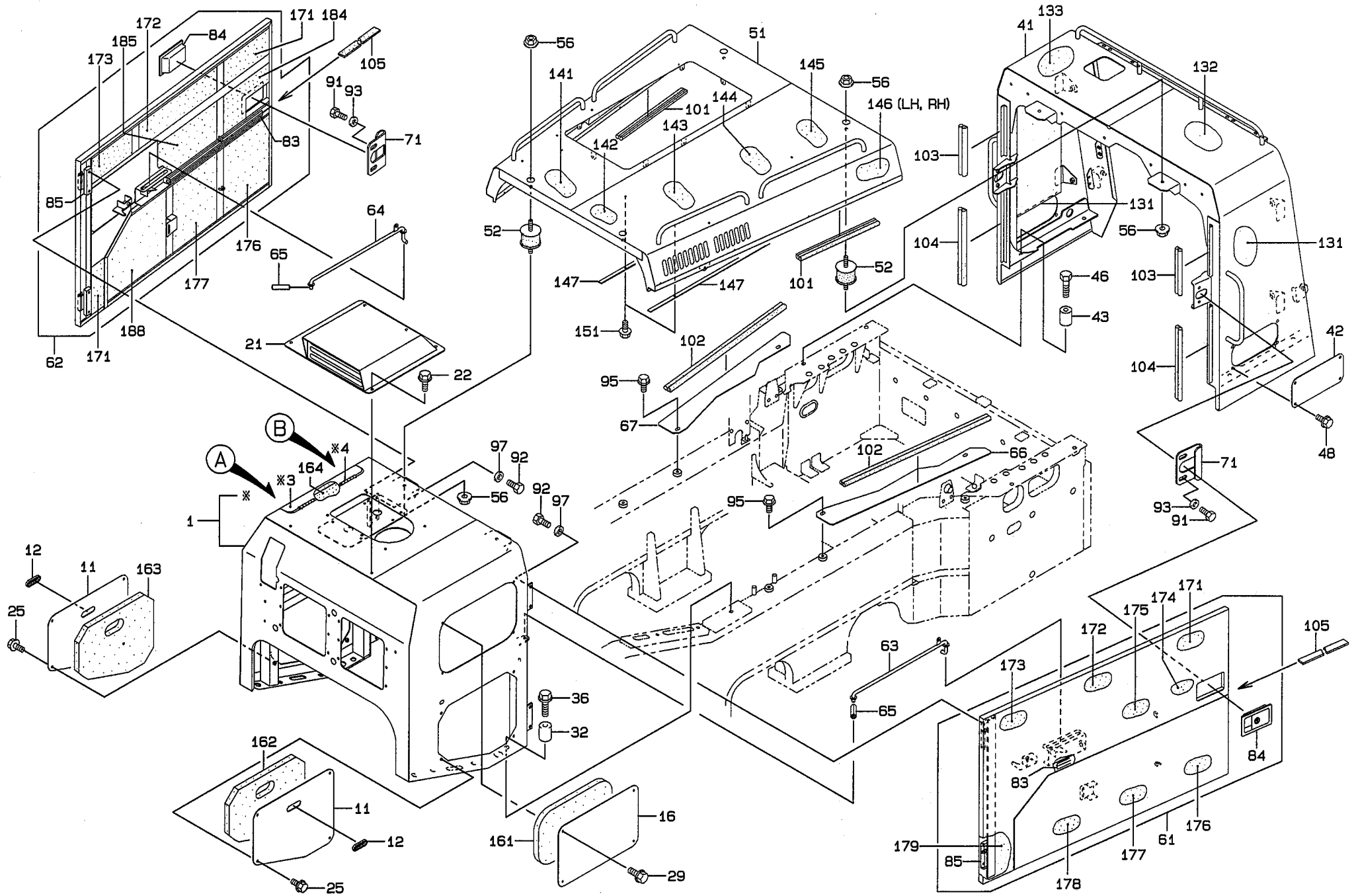

DETAIL OF STUD MOUNT

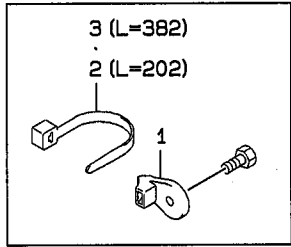

DETAIL OF CLAMP

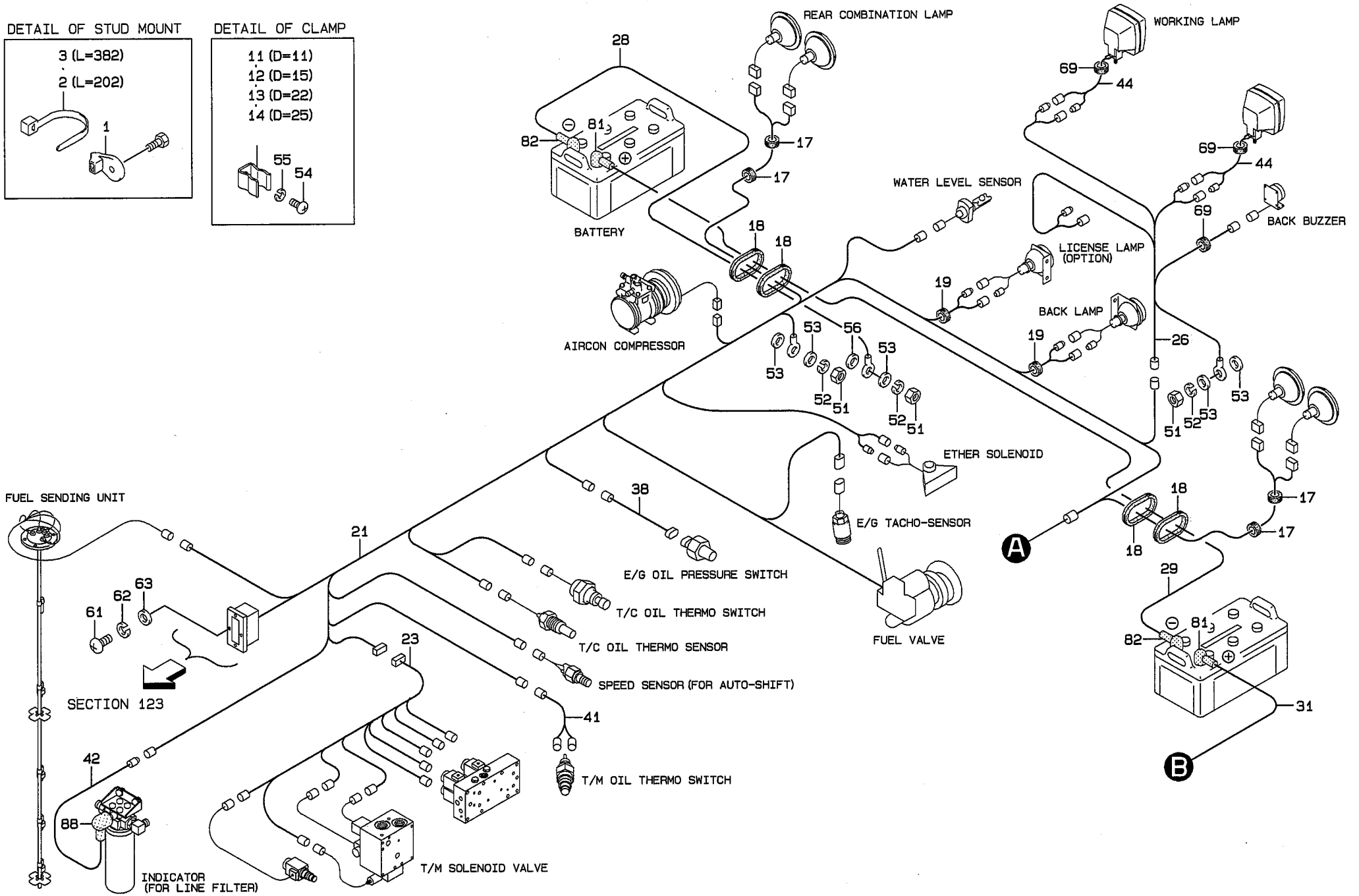
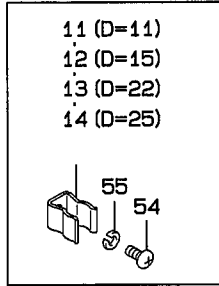

131-1

MW6-131 SEAT & SUSPENSION GROUP

ALL KITS HAVE REQUIRED FIXINGS.

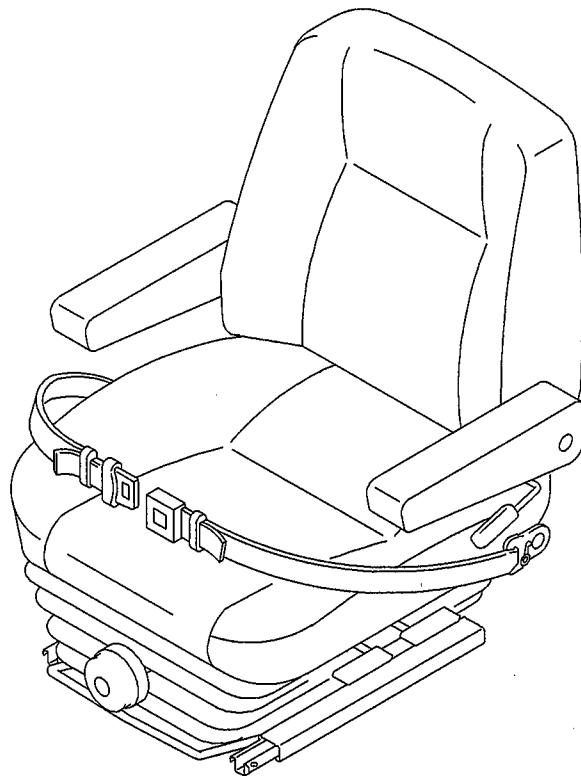

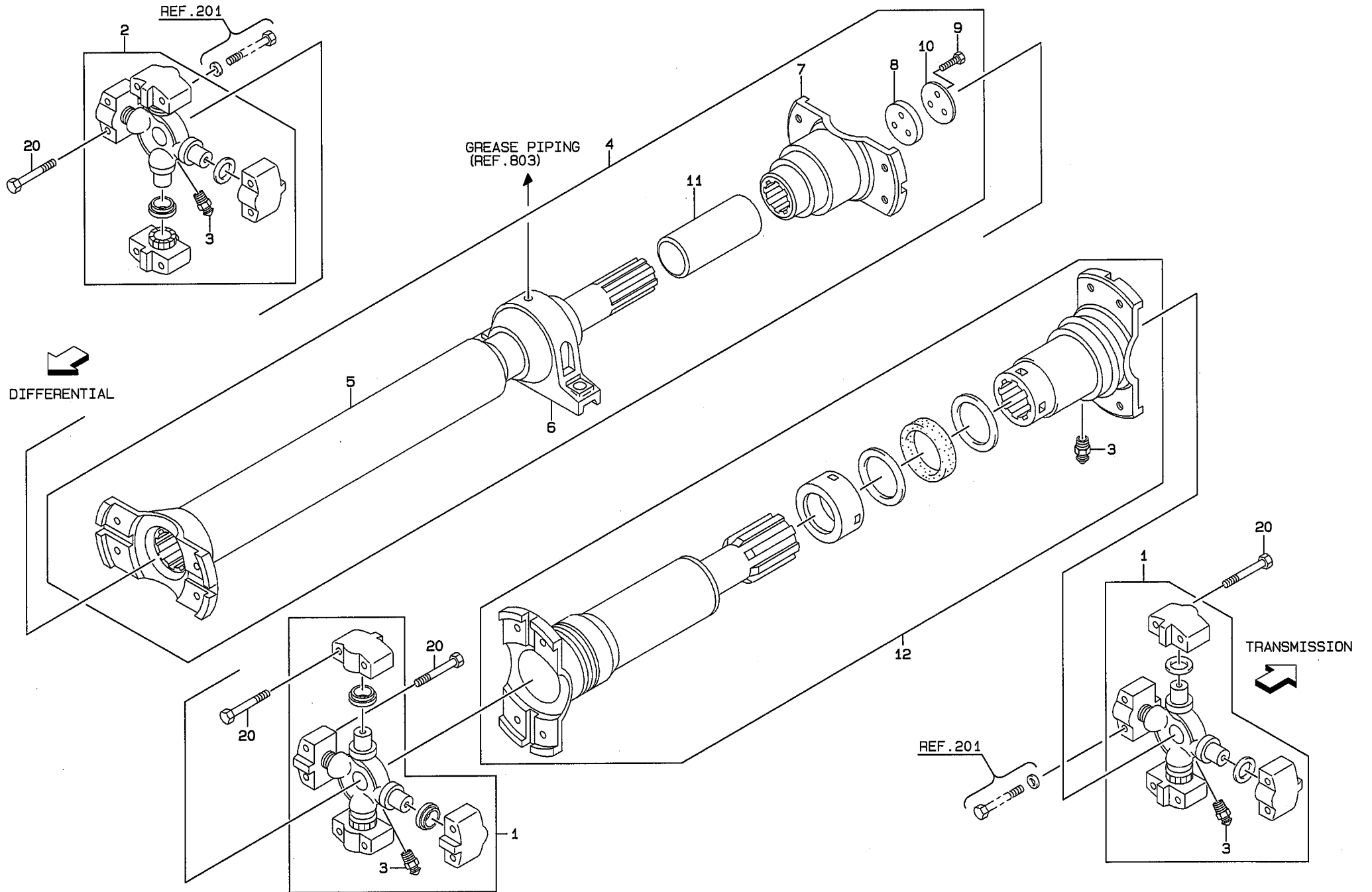

SERIAL NUMBER INDICATES THE TRANSMISSION SERIAL NUMBER.

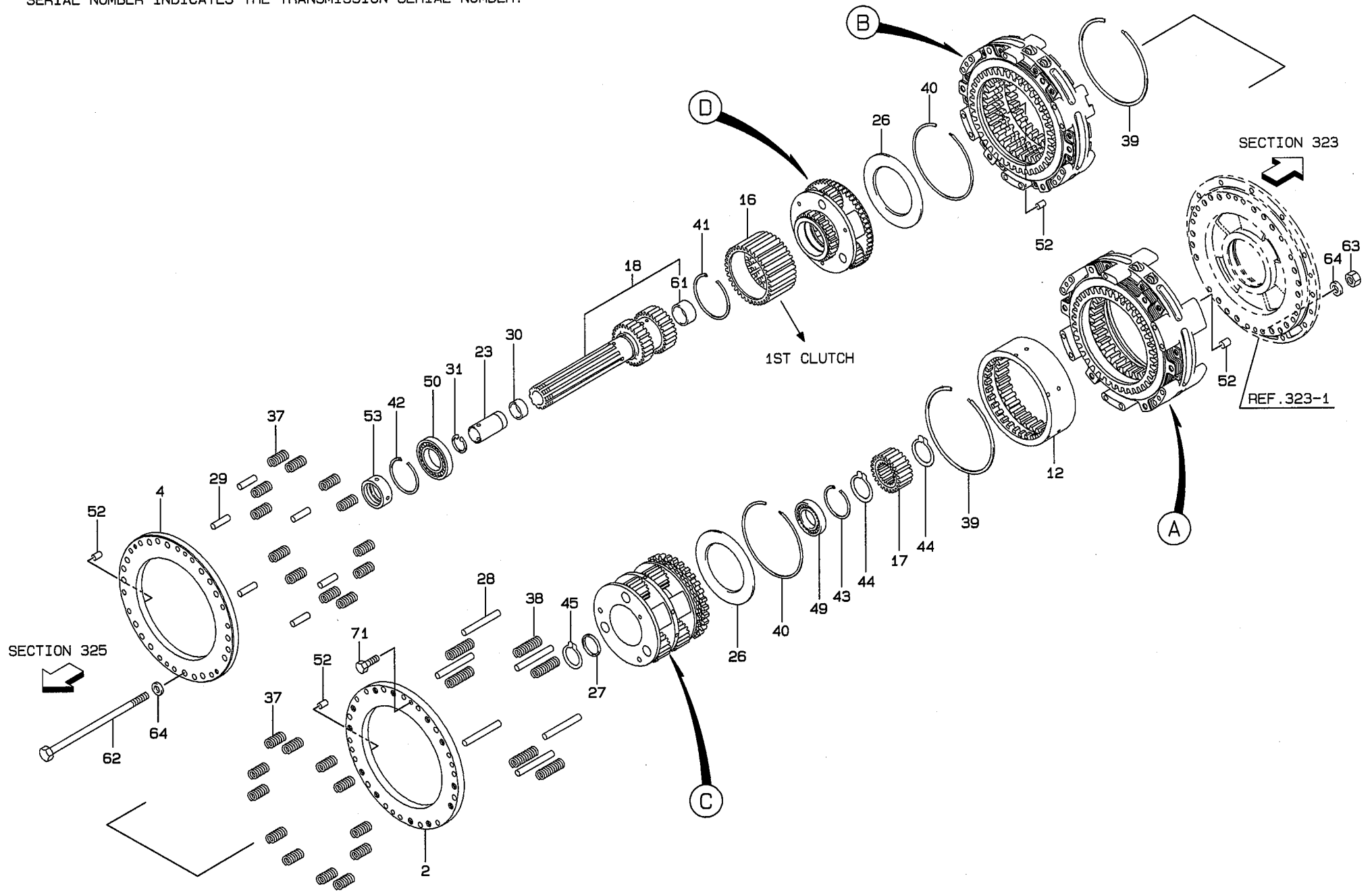

MW6-410 TIRE & DISC WHEEL GROUP

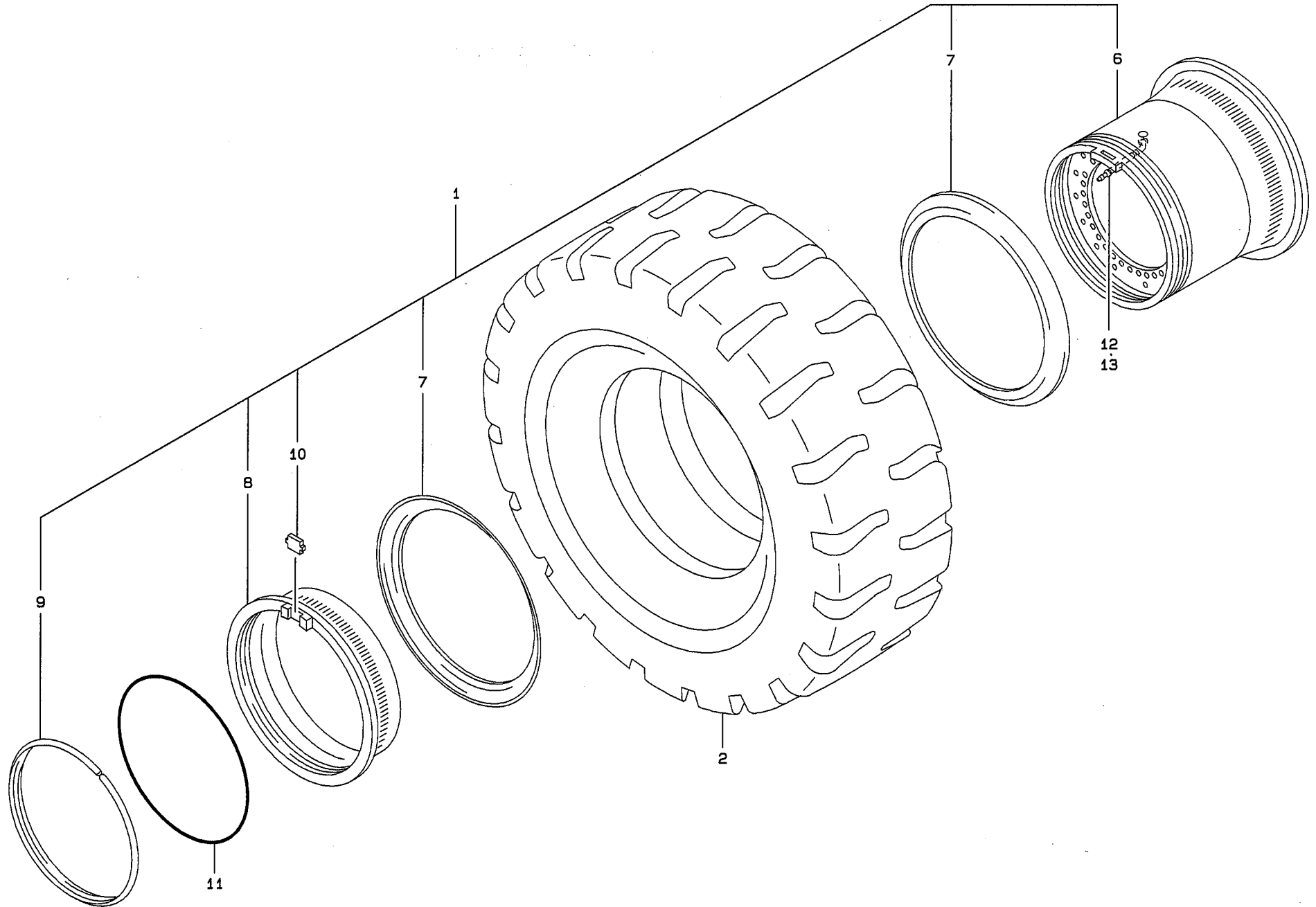

MW6-503 BRAKE LINE - AXLE (1/2)
S/N 9001 ~ 9050

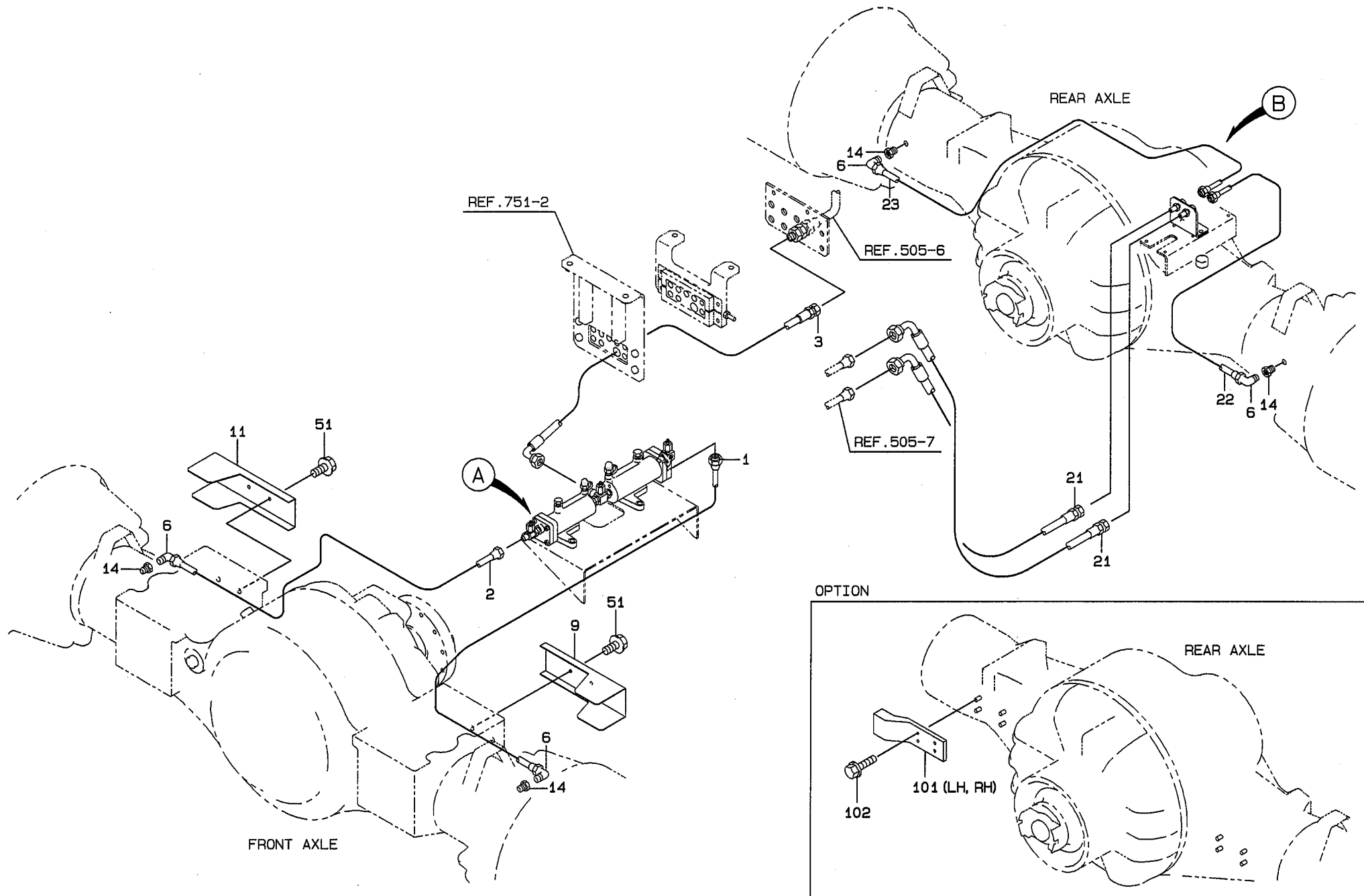

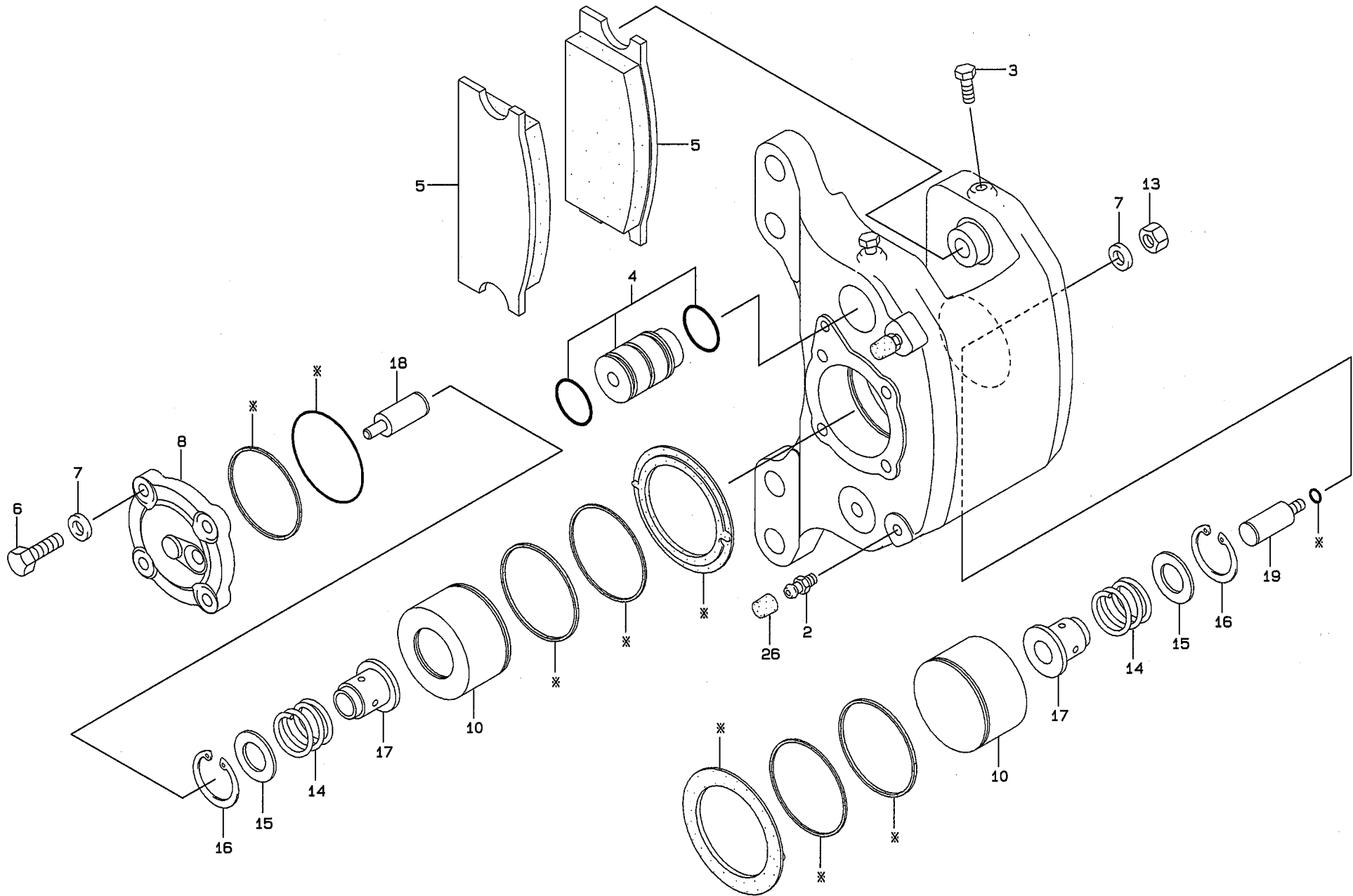

KIT (SYMBOL 40) CONSISTS OF THE PARTS WITH *.

MW6-602 TILT CASE GROUP

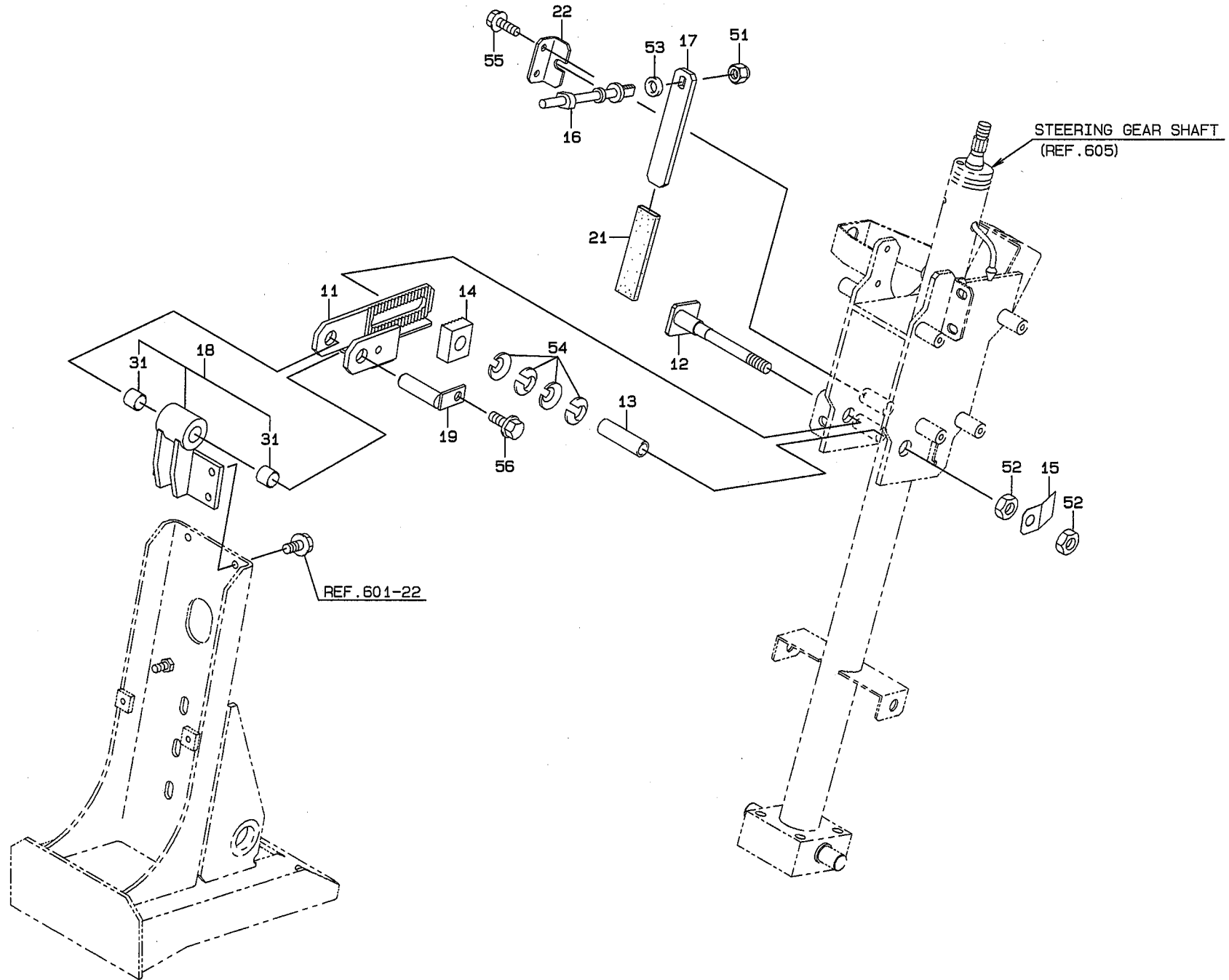

MW6-622 KICKOUT GROUP

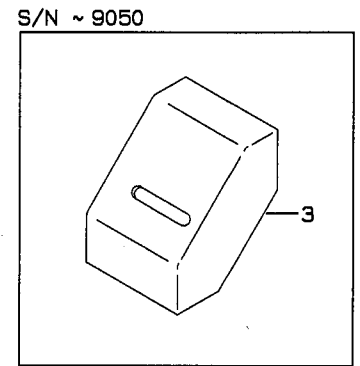
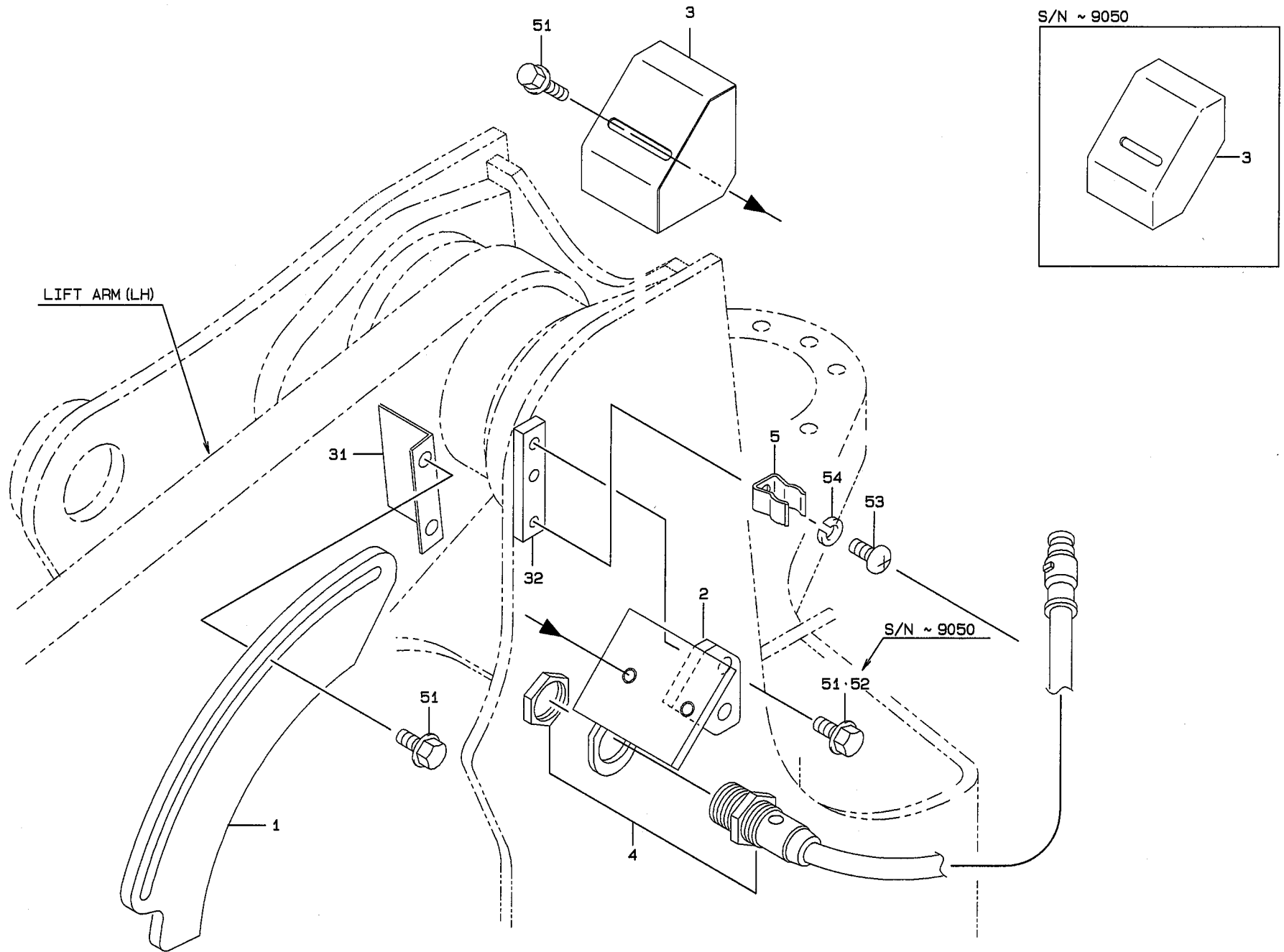

DETAIL OF PIPE HOLDER

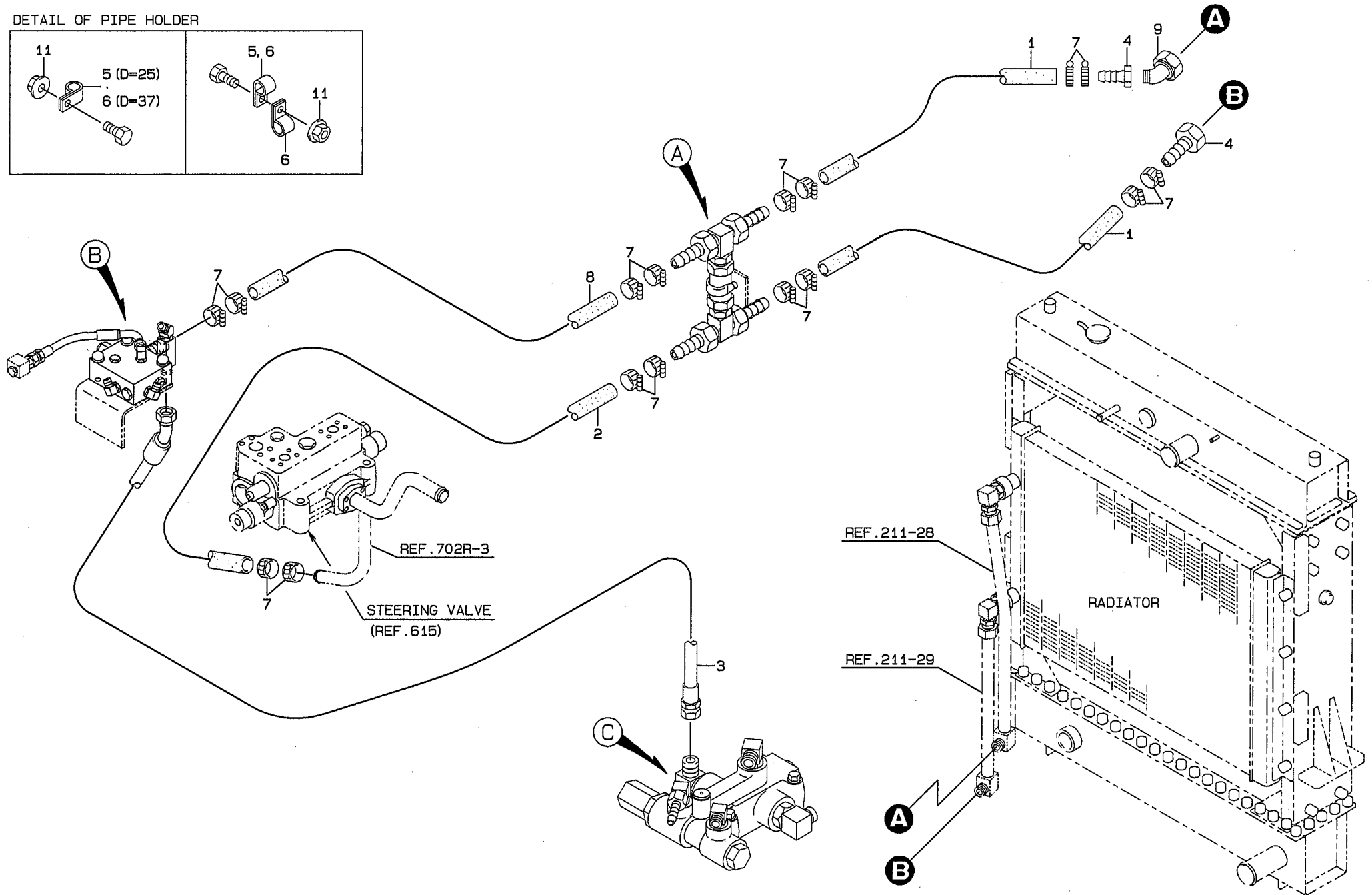
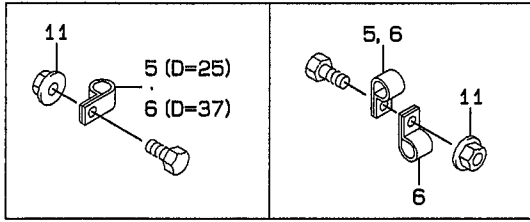

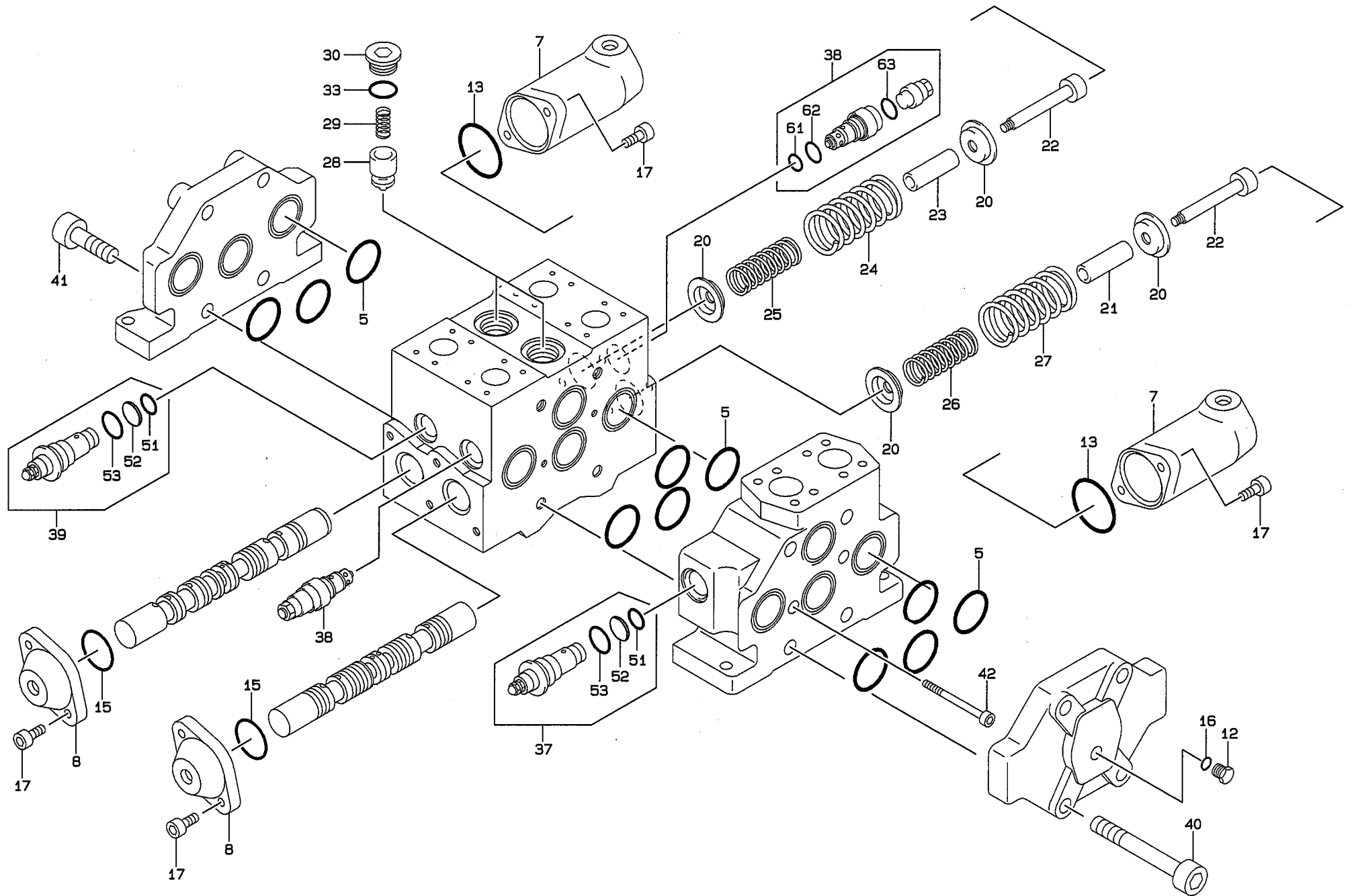

UNLOADER VALVE

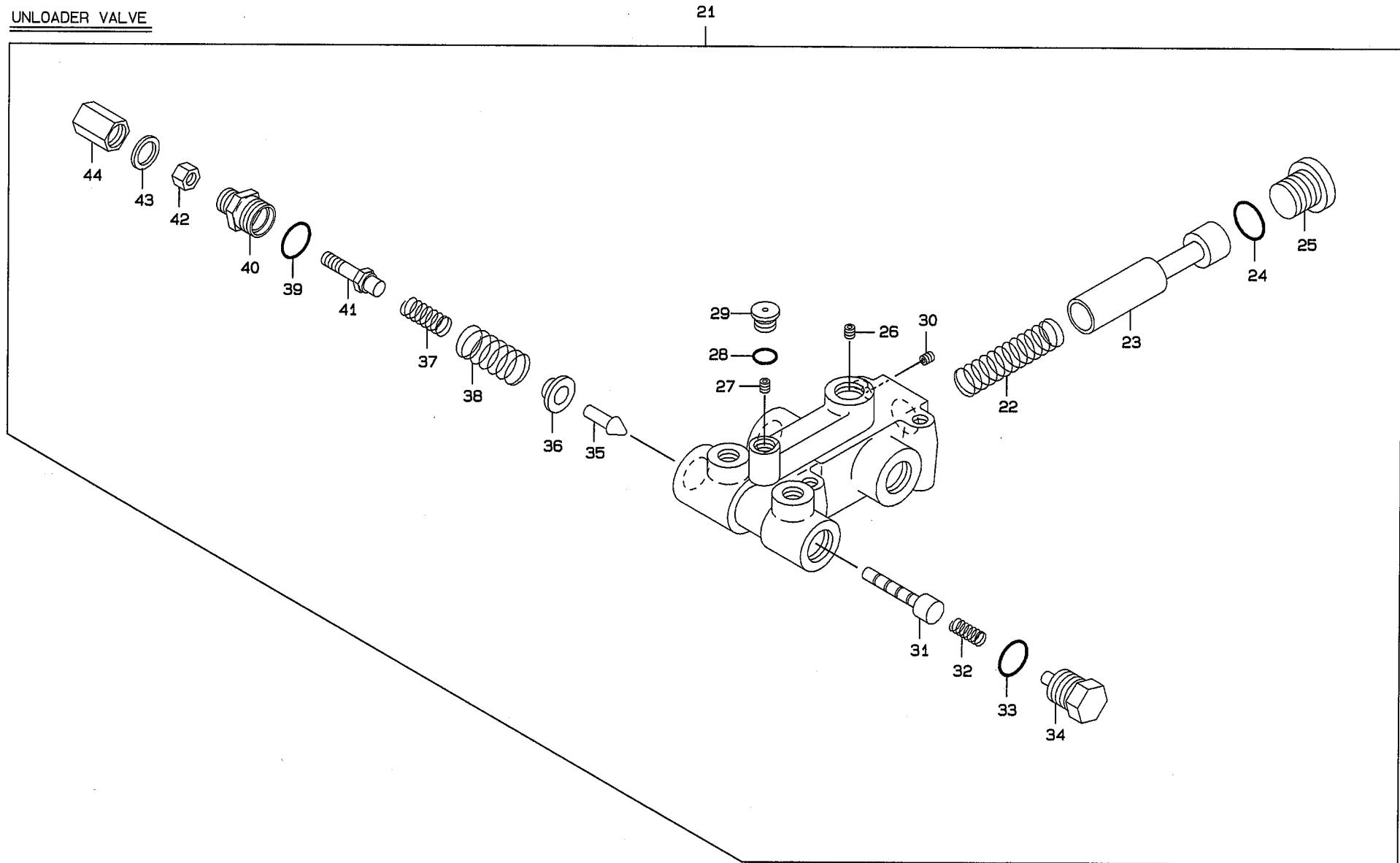

CLICK HERE TO **DOWNLOAD** THE COMPLETE MANUAL

- Thank you very much for reading the preview of the manual.
- You can download the complete manual from: www.heydownloads.com by clicking the link below



- Please note: If there is no response to CLICKING the link, please download this PDF first and then click on it.

CLICK HERE TO **DOWNLOAD** THE COMPLETE MANUAL