

YANMAR

EXCAVATOR

OPERATION & MAINTENANCE MANUAL

⚠ WARNING

- Never attempt to operate or service this Excavator until you have first read and understood all of the applicable Safety Instructions that are set forth in this Manual.

The failure to comply with all relevant Safety Instructions could result in bodily injury.
- To assure that this Manual will be conveniently available to future users, always return it to its storage compartment, when it is not being used.

LGBB7SIGMA.0(EP)

MODEL B7-SIGMA (EP)

S/N 50501 & Above

CLICK HERE TO **DOWNLOAD** THE COMPLETE MANUAL

- Thank you very much for reading the preview of the manual.
- You can download the complete manual from: www.heydownloads.com by clicking the link below



- Please note: If there is no response to CLICKING the link, please download this PDF first and then click on it.

CLICK HERE TO **DOWNLOAD** THE COMPLETE MANUAL

5-4. Warranty term for the exhaust emission control system and parts

The warranty term for the exhaust emission control system and parts shall be for five years starting from the date of delivery to the original retail purchaser, or for 3000 operating hours, whichever occurs first.

Emission related parts are as follows.

- (1) Fuel injection pump assembly.
- (2) Fuel injection nozzle assembly.

5-5. Ordering replacement parts and service calls

When ordering replacement parts or calling for service, let your dealer know the model designation, the machine serial number, and the engine serial number as well as the reading of the hourmeter.

- Machine serial number plate

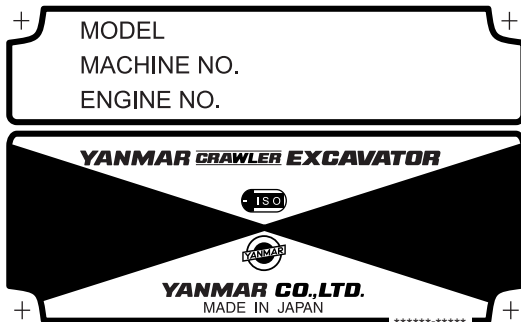

- Hourmeter

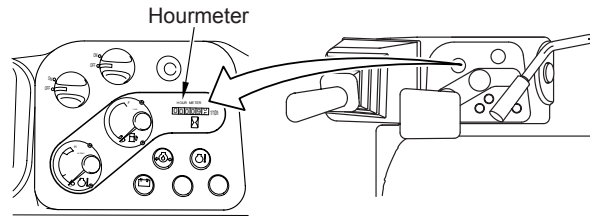

Keep fuel and oil away from sources of ignition

- Open flames can ignite fuel, oil, hydraulic oil or antifreeze solutions, which are flammable and dangerous. Special attention must be paid to the following matters.
 - Keep flammable materials away from lighted cigarettes or matches, or any other sources of ignition.
 - Never refuel while the engine is running. Smoking during refueling must be strictly prohibited.
 - Firmly tighten the caps on the fuel and oil tanks.
 - Store fuel and oil in a cool and well-ventilated place where they are not subjected to direct sunlight.
 - Fuel and oil must be stored in a place which meets all applicable safety regulations. Unauthorized persons should not be allowed entry.

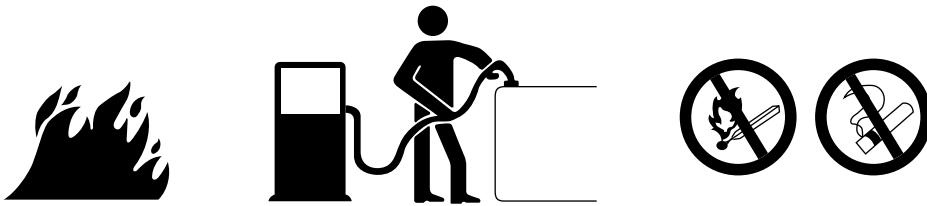
**Avoid removing filler caps while temperatures are high**

- The engine coolant, engine oil and hydraulic oil are hot and under pressure immediately after the machine stops operation. Removing caps, draining coolant or oil, or replacing a filter at such a time may cause burns. Allow temperatures to cool down and follow the procedures in this manual.
- When removing the radiator cap, stop the engine and allow the coolant to cool down, then turn the cap slowly to relieve all pressure.
- Before removing the cap from the hydraulic oil tank, stop the engine and turn the cap slowly to relieve all pressure to prevent oil from spouting out.

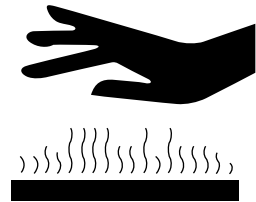
**Avoid harmful asbestos dust**

- Air containing asbestos dust is carcinogenic and is hazardous to humans. Inhalation of the air may cause lung cancer. When handling materials that may contain asbestos, keep in mind that:
 - Compressed air must not be used for cleaning.
 - Water must be used to clean the machine to prevent asbestos from scattering in the air.
 - You must work on the windward side when operating the machine in a place where there may be asbestos dust.
 - You should wear an appropriate respirator as necessary.



8-4. Precautions for the battery **DANGER****Be careful in handling the battery**

- The battery electrolyte contains dilute sulfuric acid, which can severely burn the eyes or skin. Always wear safety goggles and protective clothing when servicing the battery. If contact with the eyes or skin should occur, flush with a large amount of water and obtain prompt medical treatment.
- Because flammable hydrogen gas is produced by the battery, ignition and explosion may occur. Keep flames and sparks away from the battery.
- If you swallow battery electrolyte by mistake, drink a large amount of water, milk, or fresh eggs, and obtain medical treatment immediately.
- Before checking or handling the battery, be sure to stop the engine and turn the starter switch to the "OFF" position.
- Be careful not to cause a short circuit by placing a tool across the terminals of the battery.
- If a terminal connection is loose, sparks may be generated due to contact failure, causing possible ignition and explosion. Be sure to connect the terminals securely.
- Do not use the machine with the battery which is short of battery electrolyte. The shortage of battery electrolyte not only will reduce the life of the battery but also could cause an explosion.

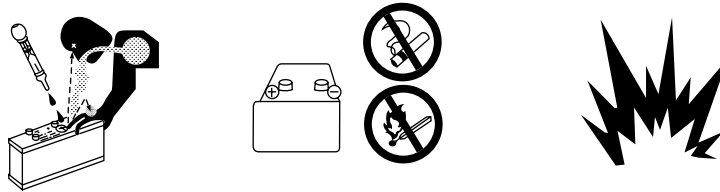
 **WARNING****Observe the procedures for starting the engine using booster cables**

- When you start the engine using booster cables, wear safety goggles.
- If you start the engine by taking electric power from another machine, do not allow your machine to contact the other machine.
- To connect the booster cables, begin with the positive terminal, and to disconnect them, begin with the negative terminal (ground side).
- If a tool simultaneously touches the positive terminal and the machine, potentially hazardous sparks may be generated.
- Do not connect the booster cables to the terminals in reverse polarity. In other words, never connect the negative terminal on one machine to the positive terminal on the other machine.
- As the last step, connect the negative booster cable terminal to the upper structure frame. At that time, sparks will be generated. Consequently, connect the terminal to a point as far away from the battery as possible.

For information about starting the engine using booster cables, refer to Section "17-3. If the battery is overdischarged".

Hazards from high-pressure grease when adjusting the track crawler tension

High-pressure grease is enclosed in the track crawler adjuster.

Failure to use the specified procedures for adjusting the track crawler tension could cause grease plugs or nipples to eject, which could result in bodily injury.

- Do not loosen the grease draining plug more than one turn.
- Never position your face, hands, legs, or body in line with the grease draining plug and valve.

For information about adjusting track crawler tension, refer to Section "25-2. Nonperiodic services".

**Rotating radiator fan and fan belt**

- Never contact the rotating radiator fan or fan belt with any object.
- Contacting the rotating radiator fan or fan belt with any object can result in serious bodily injury.

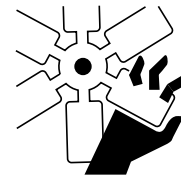
**Processing wastes**

- Do not dispose of waste oil in the sanitary sewer system.
- Always drain the oil from the machine into a secure container, and never directly to the ground.
- When disposing of toxic wastes such as fuel, oil, cooling water, solvent, filters, and spent batteries, comply with all applicable disposal regulations.

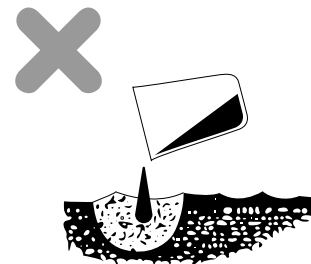

11. Identification of Important Parts

11-1. Overview of the machine

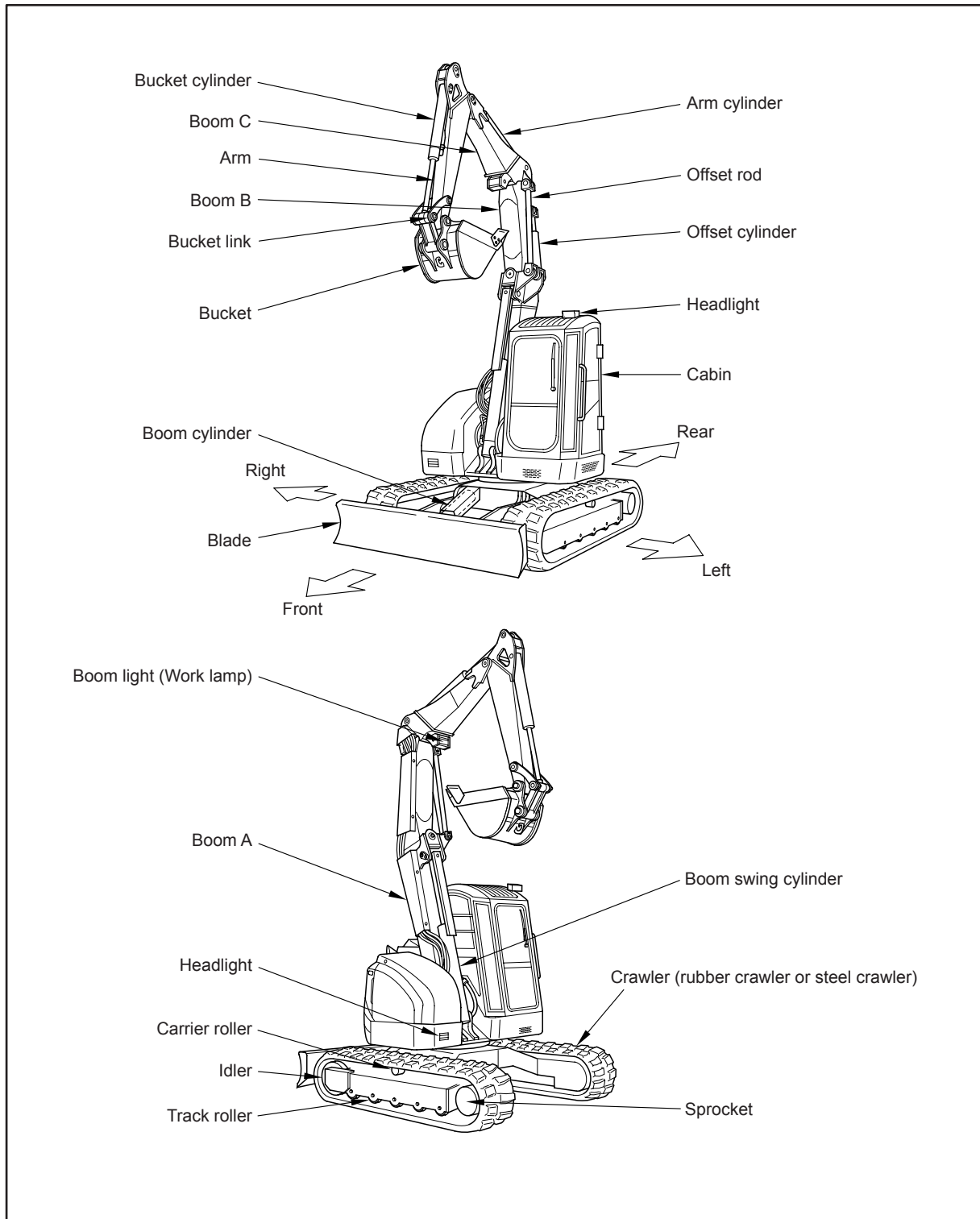

(4) Travel levers and pedals

The travel levers and pedals control the traveling of the machine.

! WARNING

- If the blade is in the reverse direction, the travel levers should also be operated in reverse for forward and backward travel.
- When operating the travel levers, you must check to see if the blade is in the normal position or in the reverse position. Note that the blade is in the normal position when the sprocket is in the rear. Refer to Section "11-1. Overview of the machine".

When the blade is in the normal position:

Forward : Push the travel lever forward.

Step on the front side.

Reverse : Pull the travel lever backward.

N (Neutral) : The machine stops.

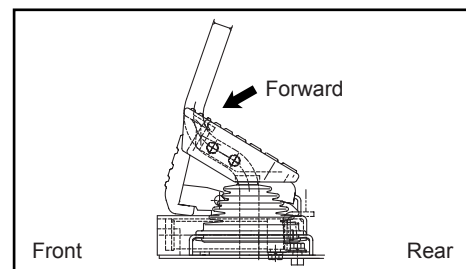
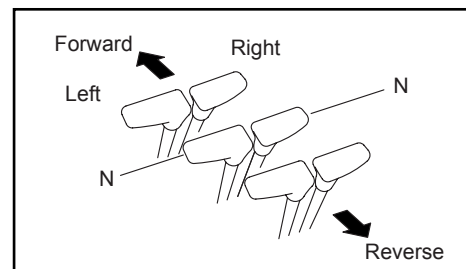
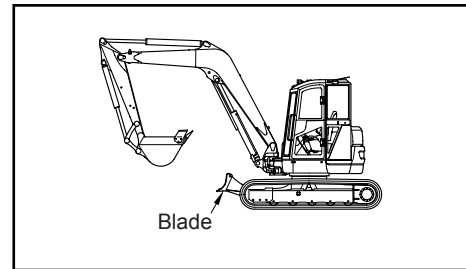

(5) Accelerator lever

The accelerator lever controls the engine speed (output).

(A) Idling : Push the lever fully forward.

(B) Run : Pull the lever fully backward.

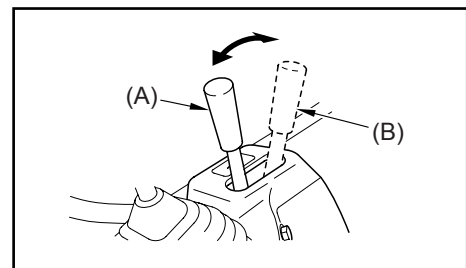

(6) Blade lever

Use this lever to control the blade.

IMPORTANT

The blade lever is not locked by setting the lock lever to the lock position. Never touch the blade lever when not operating the blade.

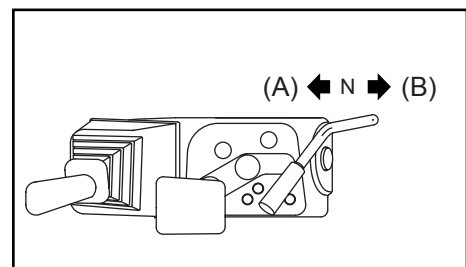

(A) : Down : Push the lever forward.

(B) : Up : Pull the lever backward.

N (Neutral) : When released, the lever will return to the neutral position and the blade is held as it is.

12-15. Fuse

⚠ CAUTION

- When replacing a fuse, be sure to turn off the power by turning the starter switch key to the OFF position.
- Using the wrong fuse or shorting out a fuse holder could damage the gauges, the electrical equipment and the wiring due to overheating.
- If a new fuse blows out immediately after replacement, there may be a problem with the electrical system. Ask your dealer for assistance.

■ The following two types of fuses are used in the electrical wiring circuit :

Blade fuse

- Protect the electrical equipment from overcurrent which exceeds the allowable limit of the electrical equipment.
- Protect the wiring from overcurrent which exceeds the allowable limit of the wiring due to a problem with the electrical equipment.

Slow-blow fuse

- Protect the electrical equipment and the wiring from a burnout caused by overcurrent which flows in the circuit for large-capacity current when a problem occurs (such as short-circuit due to breaking of wire).

■ Position of the fuse

Blade fuse

- It is installed on the front right of the seat mount.

Fusible link

- It is installed on the battery positive cable (red) side of the battery inside the cover.

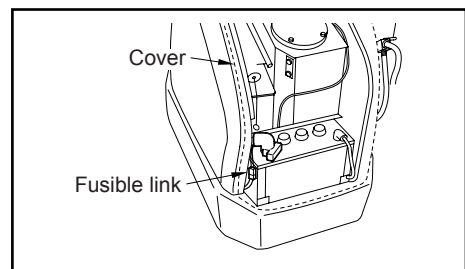
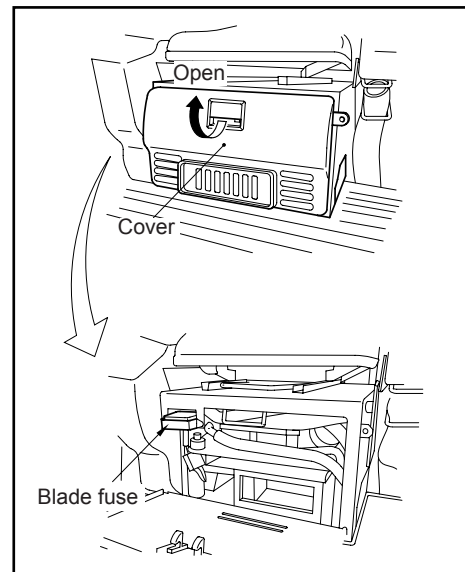

■ **Checking the electrical equipment**

 **CAUTION**

If a fuse blows out frequently, contact your dealer for assistance.

Check fuses for damage, wiring for poor connections or short circuits, and battery terminals for corrosion or loose fits. Take corrective action.

Check the following items after the starter switch is turned to the "ON" position.

1) Check the monitor functions

- Check the fuel gauge, water temperature gauge, and hourmeter.
- Check the engine oil pressure alarm lamp, charge alarm lamp, water temperature alarm lamp.

2) Check that all switches function correctly and all lamps light correctly.

- Check the horn
- Check the cabin (canopy) lights, and boom lights
- Check the one-touch decelerator function
- Check the wiper function. (for cabin)
- Check the room lamp for lighting. (for cabin)
- Check the heater function. (for cabin)

13-5. Steering

13-5-1. Steering (turning the machine)

⚠ WARNING

Always check the position of the blade before operating the travel levers.

When the blade is in the rear, the travel levers operate in reverse of normal operation.

To steer the machine, operate the travel levers.

Do not turn the machine too sharply. Before spin-turning, always stop the machine first.

Operate the two travel levers (1) as follows:

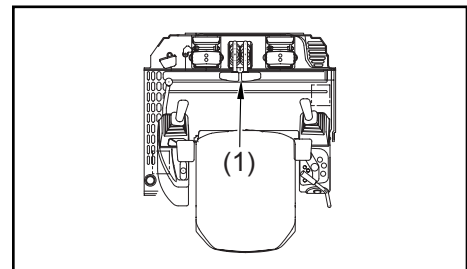

■ Steering the machine when it is not traveling

To turn left, push the right travel lever forward and start traveling forward to the left. Pull the right travel lever back and start traveling in reverse to the left.

Note :

To turn right, operate the left travel lever in the same manner as above.

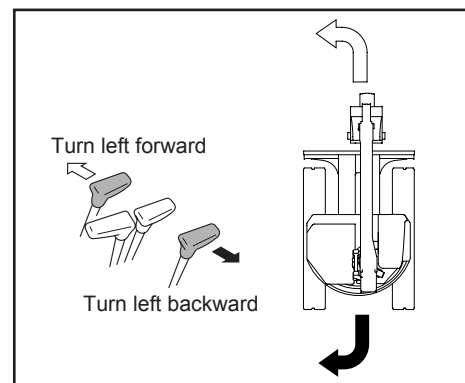

■ Steering the machine while traveling (the left and right travel levers are both tilted in the same direction)

To turn left, return the left travel lever to the neutral position.

Note :

To turn right, return the right travel lever to the neutral position.

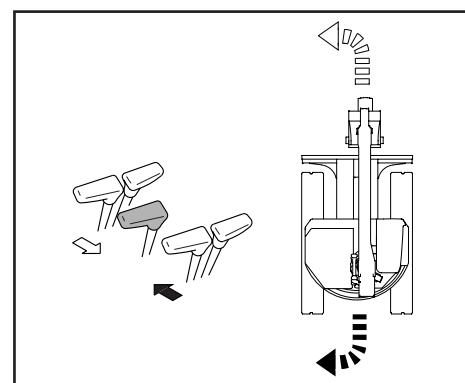

13. Operating Instructions

■ **Braking when going down a slope**

When going down a slope, you can automatically brake the machine by setting the travel levers to the neutral position.

■ **When the crawler is slipping**

If you cannot climb a slope by operating the travel levers because the crawler is slipping, retract the arm and use the pull-back power of the implement to help you climb the slope.

■ **When the engine stops**

If the engine stops while climbing a slope, set the travel levers to the neutral position, stop the machine, and restart the engine.

■ **Precautions for traveling on a slope**

Do not open or close the cabin side door on a slope.

Doing this may cause the door to swing open or closed very rapidly.

Be sure to lock the cabin side door in either the open or closed position.

CLICK HERE TO **DOWNLOAD** THE COMPLETE MANUAL

- Thank you very much for reading the preview of the manual.
- You can download the complete manual from: www.heydownloads.com by clicking the link below



- Please note: If there is no response to CLICKING the link, please download this PDF first and then click on it.

CLICK HERE TO **DOWNLOAD** THE COMPLETE MANUAL

13. Operating Instructions

13-19. Inspection requirements after stopping the engine

- 1) Check oil and water for leaks, and visually inspect the implement, the machine, and the undercarriage by walking around them.
If there are any leaks of oil or water, or any observed abnormality, take corrective action.
- 2) Completely fill the fuel oil tank.
- 3) Confirm that the engine compartment is free of any foreign matter.
Combustibles or dust in the engine compartment may cause a fire. Remove them, if any.
- 4) Remove mud adhering to the undercarriage of the machine.

13-20. Locking

Make sure that you lock the following parts :

(1) Engine hood

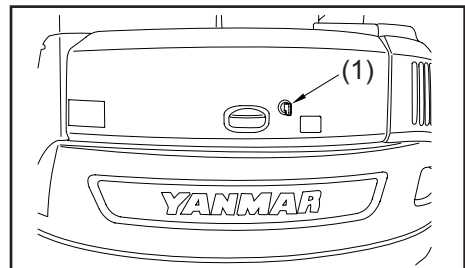

(2) Bonnet B

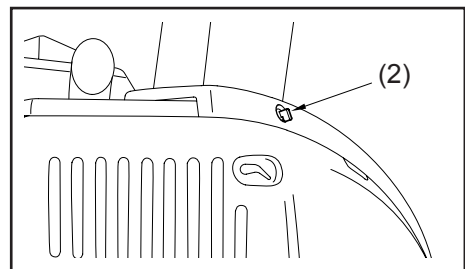

(3) Side door (for cabin)

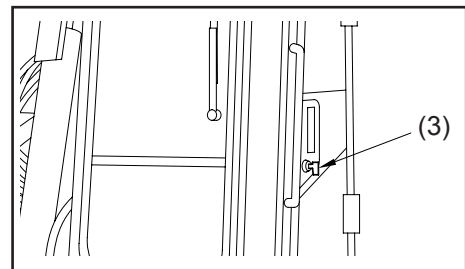

Note :

The starter switch key is used to lock all of the items mentioned above.

13. Operating Instructions

■ Precautions

- Make sure the P.T.O. selector valve is in the double acting position.
Refer to Section "13-22-1. Description of stop valve, P.T.O. selector valve, P.T.O. pedal and pedal lock".
- Always use the general attachments in accordance with the handling instructions in the operation manuals provided by the manufacturers of the general attachments.

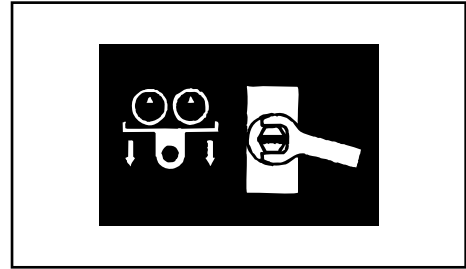

13-22-4. Long-term storage

If a hydraulic tool will not be connected, clean it before use again.

Operating the P.T.O. pedal when no attachment is mounted may cause system overheating.

13-22-5. Specification

Hydraulic oil pressure specification

- Oil flow rate : 18.5 GPM (70 L / min) at 0 bar.
- (Depends from the pressure).

16. Long-term Storage

16-1. Before storing

IMPORTANT

When storing the machine, set up the machine as illustrated in the figure at the right, to protect the hydraulic cylinder rods from becoming corroded.

When storing the machine for a long period, do the following:

- Clean all parts and store the machine indoors. If you have to store the machine outdoors, park the machine on level ground and cover it with a protective sheet.
- Apply lube oil and grease to the machine and replace the engine oil.
- Apply a small amount of antirust to exposed parts of the hydraulic cylinder rods.
- Fill the battery with distilled water up to the upper level mark. After the battery has fully recharged, disconnect the negative terminal, and cover the battery or remove the battery from the machine to store it.
- Add an anti-freeze to the cooling water if the air temperature can fall below 32°F (0°C).

Because a YANMAR genuine long-life coolant (LLC) is added to the cooling water, you need not change it until the temperature falls below -31°F (-35°C).

If the temperature falls below -31°F (-35°C), refer to Section "25-2. Nonperiodic services" to control the density of the cooling water.

- Lock the control levers and pedals with the lock levers and pedal guards respectively.
- Antirust

When stored near the sea or in a place exposed to sea breezes, the machine easily becomes rusty. Carefully apply an antirust to all exposed parts of the piston rods and cover the machine with a polyethylene sheet or oil paper.

Recommended antirust	Manufacturer
P-1300 (Solvent cutback rust preventive oil)	Nihon Sekiyu
P-3 (Solvent cutback rust preventive oil)	Japan Energy
P-300 (Solvent cutback rust preventive oil)	Cosmo Sekiyu

Some antirust solvent damages rubber materials. Be sure to use the recommended antirust or its equivalent.

- To prevent condensation inside the fuel tank, either drain the fuel tank or fill the tank completely.

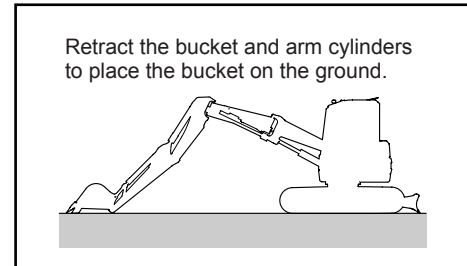

17. Troubleshooting

17-4-2. Machine body

- Contact your dealer for assistance, regarding the measures indicated in parentheses in the list below.
- If any abnormalities or troubles are encountered that are not included among those shown below, ask your dealer for assistance.

Trouble		Cause	Measure
Machine body	Power or speed of moving part is low.	<ul style="list-style-type: none"> • Deteriorated function caused by worn hydraulic pump • Pressures at system relief valve or circuit relief valve of control valve have dropped below set values • Damaged hydraulic cylinder • Insufficient amount of hydraulic oil • Clogged filter 	<ul style="list-style-type: none"> (• Replace hydraulic pump.) (• Check and repair valves.) (• Check and repair.) • Replenish hydraulic oil up to specified level. • Clean or replace filter.
	Upperstructure does not swing or does not swing smoothly.	<ul style="list-style-type: none"> • Insufficient amount of grease • Defective swing brake valve • Defective swing motor • Swing brake has not released 	<ul style="list-style-type: none"> • Check and grease. (• Check and repair.) (• Check and repair.) (• Check and repair.)
	Temperature of hydraulic oil is too high.	<ul style="list-style-type: none"> • Insufficient amount of hydraulic oil • Overload 	<ul style="list-style-type: none"> • Replenish hydraulic oil up to specified level. • Lower load.
	Machine does not move straight.	<ul style="list-style-type: none"> • Improperly adjusted crawler or trapped foreign material • Damaged hydraulic motor • Defective hydraulic pump • Defective control valve • Damaged sprocket, idler or track roller 	<ul style="list-style-type: none"> • Adjust or clean. (• Check and repair.) (• Check and repair.) (• Check and repair.) (• Check and repair.)

19-1-4. Grease

- Grease ensures smooth operation of moving parts such as connectors and prevents operating noises.
- The nipples not listed on the pages for periodic service are those used for overhaul purposes. Normally it is not necessary to refill them.
Grease them if any abnormal condition arises after long term use.
- Wipe away all excess grease after greasing.
Carefully wipe the excess grease from all moving parts which might be easily worn by adhered sand or grit.

19-1-5. Storing the oil and fuel

- Store the oil and fuel indoors so that they will not be contaminated by impurities such as water or dust.
- When you store oil or fuel in drums for a long period, position them so that their outlets align in a straight line (to prevent moisture absorption).
When storing the oil or the fuel outdoors, cover the drums with a waterproof sheet.
- To avoid deterioration caused by long-term storage, use the oil on a first-in first-out basis.

19-1-6. Filter

- The filters are very important parts which prevent impurities from getting into critical devices through the lube oil, fuel and air systems.
Replace the filter elements periodically according to the instructions of the Operation Manual.
Under difficult conditions, you need to replace the filter elements earlier than suggested in the Operation Manual depending on the type of oil and fuel (sulfur content).
- Never reuse the filter elements (cartridge type) by cleaning them.
- When replacing a filter element, confirm that no metallic dust or foreign solids are present on the old filter.
If they are found to be present, contact the nearest dealer.
- Do not unpack the filter element before use.
- Use YANMAR genuine filter elements.

24. Maintenance Table

Check and service points	Page
■ Every 50 hours	
Greasing the swing gear and the swing bearing	3-48
Draining the water and deposits in the fuel tank	3-48
Cleaning the water separator element	3-49
■ Every 100 hours	
(Perform the same maintenance as indicated for every 50 service hours)	3-49
■ Every 250 hours	
Replacing the engine oil and the engine oil filter element	3-50
Checking and cleaning the air cleaner	3-52
Checking and replenishing the lube oil for the travel reduction gearbox	3-54
Checking and replenishing the lube oil for the swing reduction gearbox	3-55
Checking and cleaning the radiator fin	3-56
■ Every 500 hours	
Replacing the fuel filter element	3-57
Replacing the air cleaner element	3-59
Replacing the hydraulic oil return filter element	3-60
■ Every 1000 hours	
Replacing the lube oil for the travel reduction gearbox	3-61
Replacing the lube oil for the swing reduction gearbox	3-62
Replacing the hydraulic oil and cleaning the suction filter element	3-63
Checking and adjusting the intake/exhaust valve clearances	Ask your dealer
Checking and adjusting the fuel injection valve	Ask your dealer
■ Every 2000 hours	
Checking and replacing fuel piping, cooling water piping	Ask your dealer
Lapping the intake/exhaust valves	Ask your dealer
Checking and adjusting fuel pump	Ask your dealer

25-2-3. Replacing the rubber crawler

! WARNING

- To replace the rubber crawler with a new one, work with a partner. You must operate the machine in response to signs from your partner.
- Because the rubber crawler is replaced with the machine in a raised position, there is a danger that the machine may accidentally fall. Do not move any parts other than the rubber crawler to be replaced in doing the job.
- The high internal pressure of the grease can cause the nipple valve to eject.
When you loosen the nipple valve (1), do not loosen it more than one turn.
At this point, do not loosen any parts other than the nipple valve (1). Also, do not turn your face toward the nipple valve (1).
- If the tension of the rubber crawler cannot be loosened by the procedure described here, ask your dealer to repair the rubber crawler.

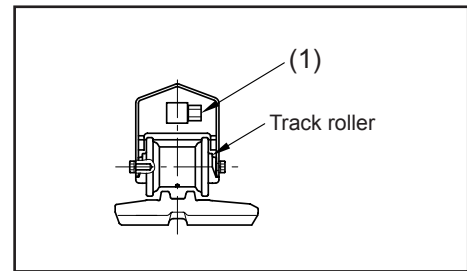

■ Replacing the rubber crawler

- Prepare a grease gun and steel pipes.

25. Procedures for Maintenance

■ How to clean the inside of the cooling system

■ Things to prepare

- Container for cooling water
Capacity : 9.20 Qts. (8.7 L) or more
- Hose for supplying the water

- 1) Swing the upper structure so that the drain plug is positioned in the middle of the right and left crawlers.
- 2) Put the container for cooling water under the drain plug.
- 3) Open the bonnet B, slowly remove the radiator cap, pour in the washing agent and mount the cap.

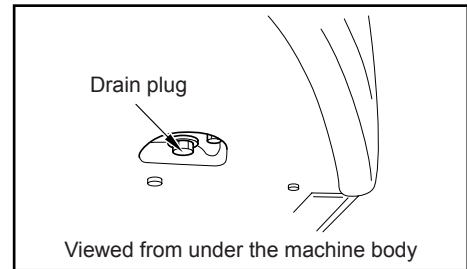

IMPORTANT

Washing methods vary depending on the manufacturer of the washing agent.

Follow the instructions of the manufacturer.

- 4) Start the engine until the water temperature rises to 176 °F (80°C) or more and idle the engine for 10 to 15 minutes. Then stop the engine.
- 5) After the engine has cooled down, slowly loosen the drain plug to drain the water, and remove the radiator cap.
When the drain plug is removed, the water in the radiator is completely discharged.
- 6) After the water is completely discharged, reinstall the drain plug and pour tap water into the water supply port of the radiator.
- 7) When the cooling system is filled with water, remove the drain plug, idle the engine and flush the cooling system with running water until clean water comes out.
While flushing with running water, always keep the cooling system completely filled with water by regulating the amounts of water to be drained out and poured in.
Hold the water supply hose securely while flushing with running water.

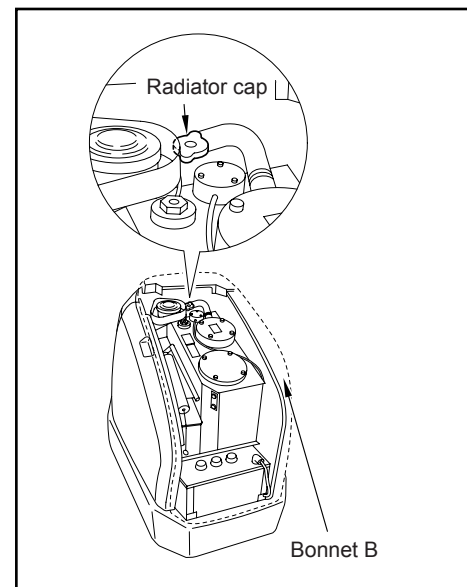

25-4. Maintenance every 50 service hours

25-4-1. Greasing the swing gear and the swing bearing

⚠ WARNING

**Do not swing the upperstructure while greasing.
Swing the upperstructure after each stage of greasing is completed to avoid serious bodily injury.**

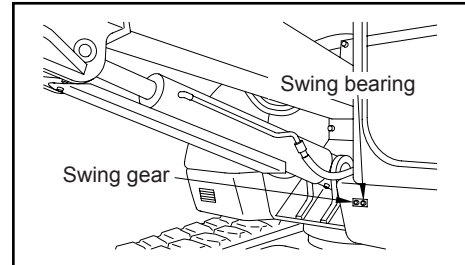

- 1) Grease the swing gear and bearing through the grease nipples indicated with arrows in the figure at the right, using a grease gun.
- 2) Swing the upperstructure in small increments and grease after each stop, until the upperstructure has made a full revolution.

25-4-2. Draining the water and deposits in the fuel tank

⚠ WARNING

Keep sparks, flames and lit cigarettes away.

■ Things to prepare

- Container for fuel waste
- 1) Swing the upperstructure so that the drain plug under the fuel tank is positioned in the middle of the right and left crawlers.
 - 2) Loosen the bolts to move the under cover in the arrowed direction.
 - 3) Put the container for fuel waste under the hose for the drain cock.
 - 4) Open the drain cock to discharge the water and dirt deposits in the fuel tank.
Take care that the fuel does not contact your body.
 - 5) When clean fuel starts coming out, close the drain cock and close the under cover.

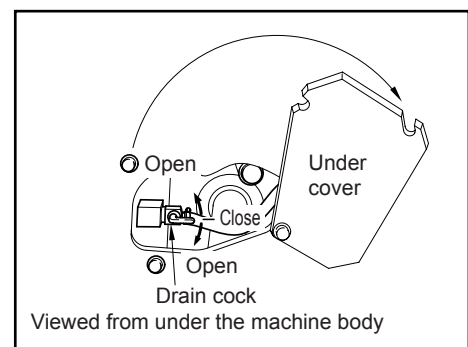

25. Procedures for Maintenance

How to release air:

This machine is equipped with an automatic air release device (solenoid pump). Release air according to the procedure.

- 1) Fill up the fuel tank.
- 2) Set the lock lever to the "LOCK" position and the accelerator lever to the "RUN" position.
- 3) Turn the starter switch to the "ON" position to turn on electricity for approximately 10 to 15 seconds. (Air is normally released in 10 to 15 seconds automatically.)
- 4) Turn the starter switch to the "START" position to start the engine.

IMPORTANT

If the engine does not start within 10 seconds, wait at least a minute before again attempting to restart the engine.

Whenever you refuel, release air in the same way. After the engine starts, sometimes it will revolve irregularly. In that case, turn the starter switch to the "OFF" position, wait for one minute or more and turn the starter switch to the "START" position again.

SPECIFICATIONS AND DIMENSIONAL DIAGRAMS

CLICK HERE TO **DOWNLOAD** THE COMPLETE MANUAL

- Thank you very much for reading the preview of the manual.
- You can download the complete manual from: www.heydownloads.com by clicking the link below



- Please note: If there is no response to CLICKING the link, please download this PDF first and then click on it.

CLICK HERE TO **DOWNLOAD** THE COMPLETE MANUAL