Operation & Maintenance Instructions

Model

111-F60L
111AT-F60L
112AT-FRE60L
113AT-FRC60L
114AT-TOW

Serial No.s:

6400 and Up
(See attached sheet
for exceptions)

PDMM#

0014

Date:

12/5/89

CLICK HERE TO **DOWNLOAD** THE COMPLETE MANUAL

- Thank you very much for reading the preview of the manual.
- You can download the complete manual from: www.heydownloads.com by clicking the link below



- Please note: If there is no response to CLICKING the link, please download this PDF first and then click on it.

CLICK HERE TO **DOWNLOAD** THE COMPLETE MANUAL

WALKIE:
GENERAL INDEX

Subject **Page**

CHAPTER 5 - MAINTENANCE (cont'd)

ELECTRICAL MAINTENANCE (cont'd)	
Contactor Table	5.59
Contactor Maintenance	5.60
Contactor Coil Replacement	5.60
Replacement Of Contactor Tips, Insulation and/or Core and Rod Assembly	5.61
Disassembly/Reassembly	5.61
Checking Components	5.63
Diodes	5.63
Testing Other Electrical Components	5.64
Throttle Potentiometer Setting	5.65
Welding Precautions	5.66

CHAPTER 6 - TROUBLESHOOTING

OVERVIEW	6.1
Suggestions	6.1
RESISTOR CONTROLS	6.3
Listing of Problems	6.3
ADVANCED TRANSISTOR CONTROLS (AT)	6.7
Listing of Problems	6.7
COMMON PROBLEMS FOR ALL TRUCKS	6.25

CHAPTER 7 - APPENDIX

ELECTRICAL SYMBOLS	7.1
ELECTRICAL SCHEMATICS	7.2
Electrical Schematic - Model 111-F60L (Resistor)	7.2
Legend - Electrical Schematic (Model 111-F60L)	7.3
Electrical Schematic - Model 111AT-F60L (Transistor)	7.4
Electrical Schematic - Model 112AT-FRE60L (Transistor)	7.5
Electrical Schematic - Model 113AT-FRC60L (Transistor)	7.6
Electrical Schematic - Model 114AT-TOW (Transistor)	7.7
Legend - AT Electrical Schematics	7.8
WIRING DIAGRAMS	7.9
Wiring Diagram - Model 111-F60L (Resistor)	7.9
Wiring Diagram - Model 111AT-F60L (transistor) Sheet 1 of 2	7.11
Wiring Diagram - Model 112AT-FRE60L (transistor) Sheet 1 of 2	7.13
Wiring Diagram - Model 113AT-FRC60L (transistor) Sheet 1 of 2	7.15
Wiring Diagram - Model 114AT-TOW (transistor) Sheet 1 of 2	7.17
HYDRAULIC	7.19

RAYMOND PRODUCTS
GLOSSARY

GRADE CLEARANCE PERCENTAGE: The maximum slope whose crest can be negotiated due to the structural limitations imposed by the underclearance and wheel base of a truck.

GRAVITY STORAGE: **1.** A storage method that allows pallets, boxes or cases to flow from rear to front in a storage system. **2.** Storage involving flow to move pallets or cases for automatic replenishment of pick slot.

GUIDEPATH: The path of wire in the floor that wire guided vehicles track.

HAND CONTROLLER: A hand held, plug-in controller that is used to operate the ELECTOTE vehicle while off the guideway. The controller enables two-direction travel with steering.

HEAD LENGTH: The dimension from the rear bumper of the truck to the vertical face of the fork carriage.

HI-RISE PICKING: A method of picking orders from storage levels above the normal pick height (above 18 feet) which requires either man aboard or AS/RS equipment.

HIGH LIFT PLATFORM TRUCK: A truck equipped with an elevating mechanism designed to permit tiering.

HOLD: An ELECTOTE traffic control feature that temporarily holds a vehicle while a specific situation occurs: i.e. blocking access of one vehicle to an intersection while a second vehicle passes through.

HOLDING AREA: A defined temporary area for staging of products during various warehouse functions.

HONEY COMBING: Creation of unoccupied space resulting from withdrawal of unit loads. Empty slots created by removal of unit loads.

HORIZONTAL TRANSPORT: A category of industrial truck designed to effectively transport material in the horizontal direction. The Electote, Walkie and 40 Low Lift are Raymond Corporation products in this category.

HOT PICK: An incoming order that takes priority over all orders presently being worked.

HOUSEKEEPING: Maintaining uniformity of unit loads, appropriate load clearances, clear aisles & general maintenance. Maintaining a clean facility.

HYDROMETER: A device used to measure density or specific gravity of the sulfuric acid-water electrolyte solution.

HY-DRIVE™ REACH: A truck that has the capability to perform both orderpicking and normal unit load reach handling.

HYR: HY-DRIVE Reach model designator.

IDENTIFY AND SORT: Separation of goods by their identification formats. Placing the proper items with the appropriate order.

INDUSTRIAL BATTERY: General term used to differentiate between batteries for heavy-duty industrial applications and those for automotive starting-lighting-ignition (SLI). (See also Motive Power Batteries)

INDUSTRIAL TRUCK ASSOCIATION (I.T.A.): An organization of industrial truck manufacturers that formalizes and publishes industry statistics. Also forms committees to address issues such as safe truck use.

INTERSECTION: A crossing or junction point of ELECTOTE guideways. Intersections may have traffic controls to allow safe merging and passing of vehicles.

INVENTORY LEVELS: **1.** Current level of each SKU in stock. **2.** Average amount of a given SKU in stock at any time. **3.** Optimum amount of a specific product maintained in inventory.

INVENTORY PROVISIONS: Proper and necessary inventory on hand.

INVENTORY TURNS: Accounting principle based on the number of times the entire inventory is used up and replenished in a given period of time.

JUST IN TIME (JIT): Controlling incoming merchandise so as to minimize inventory required to support production.

KILOWATT (KW): One thousand watts.

KILOWATT HOUR (KWH) CAPACITY: The total amount of power (volts x amps x hours divided by 1,000) that can be drawn from a battery. A battery's kilowatt hour rating is a direct measure of how much work the battery is capable of performing.

KIT: **1.** A designation given to parts that are assembled or grouped together. **2.** To bring together different units that have to be merged together.

WALKIE: DESCRIPTION
CHAPTER 1 INDEX

<u>Subject</u>	<u>Page</u>
OVERVIEW	1.1
Vehicle Specifications	1.3
Description	1.3
MECHANICAL	1.4
Drive Unit	1.4
Handle Assembly	1.4
Drum Brake	1.4
HYDRAULIC SYSTEM	1.5
General	1.5
Relief Valve	1.5
Flow Control Valve	1.5
Lowering Solenoid	1.5
Lift Cylinders	1.5
Hydraulic Reservoir	1.6
Breather Cap	1.6
Hydraulic Pump Motor	1.6
Hydraulic Pump	1.6
Check Valve	1.6
ELECTRICAL SYSTEM	1.7
Battery	1.7
Lift Limit Switch	1.7
Drive Motor	1.7
Resistor Control	1.7
Advanced Transistor Control	1.7

WALKIE: OPERATING INSTRUCTIONS

SAFETY

SAFETY

The safe operation of the truck depends upon:

- Operator application of his knowledge and skill
- Equipment care
- The operator's high regard for his safety and safety of others.

Most accidents are caused by the failure of some individual to follow simple and fundamental safety rules or precautions. For this reason **MOST ACCIDENTS CAN BE PREVENTED** by recognizing the real cause and doing something about it before the accident occurs.

Safety Guidelines List

All the following safety guidelines must be observed for maximum safe operation of the truck.

- Do not operate this truck unless you have been authorized and trained to do so. Read all warnings and instructions contained in the Operator's Manual or balance of this Chapter for the Operating Instructions.
- Do not operate this truck until you have checked all systems (all safety guards or covers must be in place and safety interlock switches operative). Report any unsafe conditions immediately. Do not operate the truck until it is corrected.
- Never check the water level in an industrial storage battery with a match or lighter. Use a flashlight. The gas given off by batteries is hydrogen, which is highly explosive.
- Operate the truck only from a designated operating position.
- Do not carry passengers.
- Do not overload the truck. Check the nameplate for capacity (load weight and load center information).
- The truck should be operated slowly and in an open area until the operator becomes thoroughly familiar with the truck controls.

WALKIE: OPERATING INSTRUCTIONS

CONTROLS

PLUGGING

Description

Plugging is the recommended method of retarding travel speed and changing direction during operational maneuvers. Plugging may also be used to stop the vehicle. This method will not stop the vehicle as quickly as braking, but will provide the operator an alternative to bring the vehicle to a smooth controlled stop.

Activation

1. Rotate the directional/speed control back through neutral to the direction opposite of vehicle travel.
2. The truck will slow down, come to a stop, then start traveling in the opposite direction. The farther past neutral the control is moved, the greater the plugging force.

FORWARD/ REVERSE DIRECTIONAL CONTROLS

Description

The operator controls the three speeds forward and reverse with convenient, thumb actuated butterfly levers on each side of the handle.

Function

Turning the butterfly switch actuates a directional contactor. The contactor applies power to the drive motor while the Advanced Transistor Control and the Multi-function Module control the amount of current flow through the drive motor. Motor speed is proportional to the amount of butterfly lever rotation.

Activation

1. Turn KEY switch to ON.
2. Pull handle down to "Power On" position.
3. To travel in the direction of the forks, rotate the lever toward the forks. To travel in the direction of the control handle, rotate the lever toward the forward end of the truck. To travel at slow speed rotate the lever slightly. Rotating the lever half-way will result in mid-range speed. For high speed rotate the lever as far as possible. The lever returns to neutral when thumb pressure is released.

STEERING

Description

The control handle is used to steer the truck.

Function

The control handle is mechanically attached to the drive unit. Pushing the handle to the left or right causes the drive unit and drive wheel to rotate.

Activation

To turn left move the handle to the left and to turn right move the handle to the right. The handle is able to rotate through a 180⁰ horizontal arc for good maneuverability.

WALKIE: INSTALLATION
CHAPTER 3 INDEX

<u>Subject</u>	<u>Page</u>
SETUP	3.1
Checking the Battery	3.1
Connecting the Battery	3.2
Lubrication	3.3
Checking the Hydraulic System	3.3
OPERATIONAL CHECKS	3.4
Drum Brake	3.4
Fork/Lift Linkage	3.4
Emergency Reverse Switch	3.4
Receiving Inspection Guide	3.4
BREAK-IN PERIOD	3.5
Introduction	3.5
Motors	3.5
Pump	3.5
Battery	3.5

WALKIE: THEORY OF OPERATION

OPERATION OF THE TRAVEL SYSTEM - RESISTOR

Battery Plugged IN/
Keyswitch S1 ON

When keyswitch S1 is turned ON the following occurs: (Refer to Figure 4.2)

Battery potential (B+) goes to:

1. The positive side of the lift (S4A) and lower (S4B) switches, both open.
2. The battery discharge meter and heater options as installed on the particular truck.
3. The positive side of brake switch (S2).

WALKIE: THEORY OF OPERATION

OPERATION OF THE TRAVEL SYSTEM - RESISTOR

Plugging - Resistor Control

Introduction

When the truck is traveling in the forward direction and the butterfly lever (directional/speed control) is rotated through neutral to the opposite direction (reverse) to slow the truck and change direction, plugging occurs.

Process

1. During normal plugging, as the butterfly lever is rotated to the opposite direction, the following occurs: (refer to Figure 4.7)
 - A. Forward switch MS1 is opened while reverse switch MS2 is closed.
 - B. Contactor M2 is closed while M1 is opened.
2. The current flow through the motor's field windings is reversed and is attempting to turn the armature in the opposite direction. However, the inertia of the truck causes the armature to continue rotating in the original direction.

NOTE: As the directional/speed control lever is rotated farther in the opposite direction both the drive motor current and torque increase. The greater the torque applied, the quicker the truck will slow and change direction.

WARNING

DO NOT PLUG THE TRUCK AT FULL SPEED IN THE OPPOSITE DIRECTION OF TRAVEL. ALTHOUGH PLUGGING IS USER SELECTABLE, THE RECOMMENDED SEQUENCE IS TO ONLY USE PLUGGING IN FIRST SPEED UNTIL THE TRUCK STOPS. THE OPERATOR MAY THEN RAMP UP TO THE REQUIRED SPEED IN THE OPPOSITE DIRECTION.

WALKIE: THEORY OF OPERATION

OPERATION OF THE TRAVEL SYSTEM - TRANSISTOR

OPERATION OF THE TRAVEL SYSTEM - TRANSISTOR

Battery Plugged IN When a properly charged battery is connected to the vehicle, battery potential (B+) goes to: (see Figure 4.13)

1. The lift motor contactor tips. (P)(open)
2. M1 and M2 contactor tips. (open)
3. The auxiliary horn control. (S18-2)
4. B+ side (S33-02) of the horn switch.
5. B+ side of the keyswitch.
6. B+ side of the Advanced Transistor Control.
7. A2 side of the Advanced Transistor Control.
8. Positive side (AA) of the drive motor.

WALKIE: THEORY OF OPERATION

OPERATION OF THE TRAVEL SYSTEM - TRANSISTOR

Emergency
Reverse Switch -
Transistor Control

If the truck direction of travel is quickly reversed by the emergency reverse switch, the AT control system will provide a rapid deceleration and an immediate acceleration in the reverse direction.

When traveling in the forward direction; if the emergency reverse switch (S25-momentary pushbutton switch) is activated: (see Figure 4.18)

1. The K1 relay is energized and contacts K1-7 and K1-1 open. This opens the circuit to M1 and M2.
2. Diode DA1-2 and DA1-3 conducts sending positive voltage to M2 (reverse).
3. Contacts K1-5 and K1-8 close momentarily activating M2.
4. An internal relay in the Multifunction module opens to activate accelerated plugging (by passes normal plugging mode) for faster direction reversal.
5. Multifunction module P19-09A activates fixed full speed resistance switches. The switches are latched for speed selection regardless of throttle input, and remain in that condition until reset by actuating the deadman switch.

NOTE: Once the emergency reverse switch is activated, the Multifunction Module locks out the M1 (Forward) contactor by opening the negative circuit (internally) at P112-33. To reset the truck for normal travel, the handle must either be set to the full vertical or full horizontal position. Turning the keyswitch OFF and then ON will also reset the Multifunction Module.

CLICK HERE TO **DOWNLOAD** THE COMPLETE MANUAL

- Thank you very much for reading the preview of the manual.
- You can download the complete manual from: www.heydownloads.com by clicking the link below



- Please note: If there is no response to CLICKING the link, please download this PDF first and then click on it.

CLICK HERE TO **DOWNLOAD** THE COMPLETE MANUAL

WALKIE: MAINTENANCE

SCHEDULED MAINTENANCE

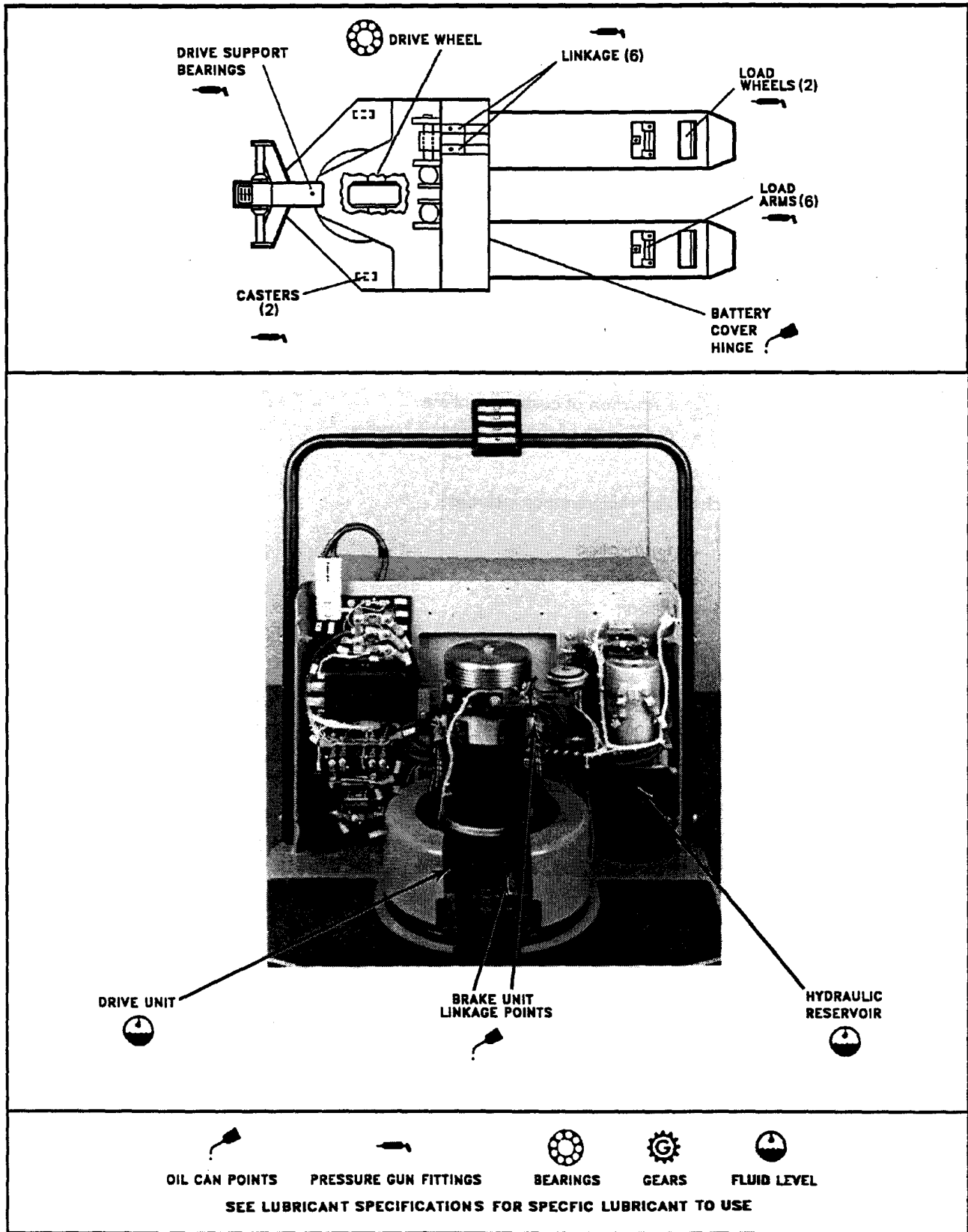

Figure 5.1 Lubrication Chart

WALKIE: MAINTENANCE

DRIVE UNIT

Drive Housing Support Bearing

After each 50 hours of operation, the support bearing should be lubricated along with all the other pressure gun fittings. After 1,000 hours of operation, or when steering becomes sloppy or stiff, check the bearing and the snap ring securing the bearing to the drive housing.

1. To gain access to the support bearing proceed as follows:

- Remove the drain plug and vent plug. Allow oil to drain.
- Disconnect the motor cables from the motor and handle harness from the terminal block.
- Block the frame.
- Attach a hoist of suitable capacity to the drive unit.
- Remove the capscrews which secure the drive unit to the frame.
- Remove the drive unit.
- Remove the snap ring that secures the bearing to the drive housing, then remove the bearing and steering ring assembly. (Refer to Figure 5.5)

2. To reassemble the support bearing proceed as follows:

- Install the bearing.
- Replace the snap ring that secures the bearing to the drive housing.
- Replace the drive unit with the hoist.
- Replace the capscrews which secure the frame to the unit and reconnect the motor cables and handle harness to the terminal block.

CAUTION

Do not remove the hoist until the capscrews are in place and torqued.

3. Replace the oil. (Refer to page 5.10 for details).

4. Replace the drain plug.

5. Replace the vent plug and the level plug.

CAUTION

Make certain the key switch is off and the battery is disconnected.

Disassembly

1. Remove the drain plug and the vent plug. Allow sufficient time for the oil to drain.

2. Disconnect the motor cables and handle harness from the terminal block.

3. Block the frame.

4. Attach a hoist of suitable capacity to the drive unit. (See Figure 5.8)

5. Remove the capscrews which secure the drive unit to the frame.

6. Remove the drive unit.

7. Separate the drive housing just above the support bearing by removing the bolts that hold the two (2) castings together. Remove the snap ring that secures the bearing to the drive housing, then remove the bearing.

8. With the housing separated, inspect the helical gears. Remove the cover on the back of the drive unit. Inspect the bevel gear teeth.

NOTE: AT THIS POINT, IF IT IS NECESSARY TO CONTINUE WITH THE DISASSEMBLY OF THE TRUCK, REMOVE THE DRIVE TIRE.

DRUM BRAKE

Brake Adjustment

1. Loosen nuts A and B. Back off nuts to provide a .50" clearance between nut B and the spring retaining bracket as shown. (See Figure 5.12)
2. Disconnect link end item C.
3. Raise handle to vertical (brake on) position.
4. Compress load spring item D by turning nuts B and F until the compressed length of the spring is 2.00" as shown.
5. Locknuts A, B, E and F.
6. Position the handle in the normal (brake off) operating position. (See Figure 5.10)
7. Connect link end item C.
8. Loosen nuts items G and H.
9. Rotate brake rod item J until brake drum drag is minimal, i.e., drum rotates freely by hand. Do not over extend rod J.
10. Tighten nuts G and H.
11. Adjust microswitch K if required. (Refer to Handle Assembly Adjustment)

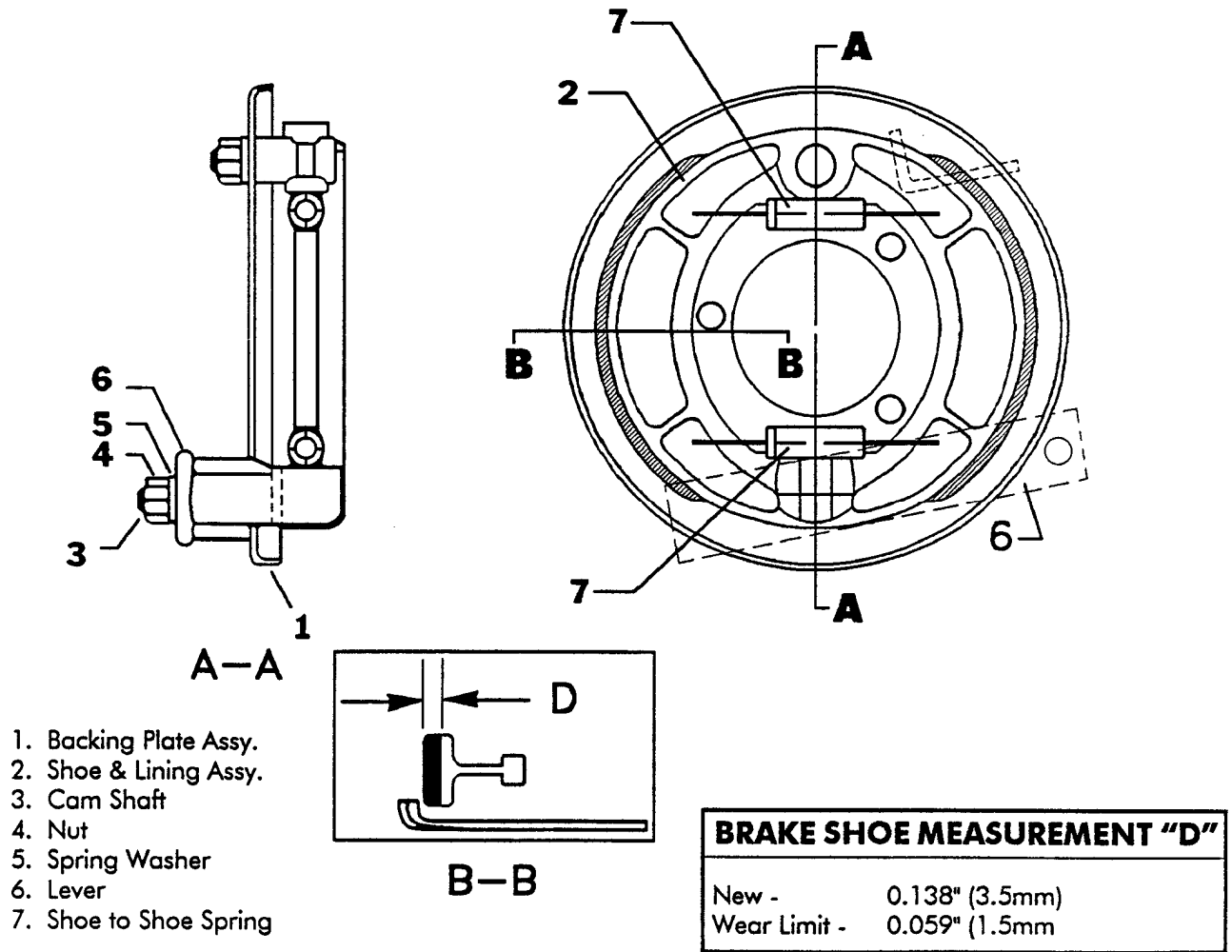

Figure 5.11 Drum Brake Unit

WALKIE: MAINTENANCE

FORK AND LINKAGE

FORK AND LINKAGE

After Every 50
Hours of Operation

Lubricate all fork and linkage pressure gun fittings.

NOTE: If fittings must be replaced, install them so that they are accessible for greasing.
Inspect the forks for proper height adjustment. Adjust if necessary.

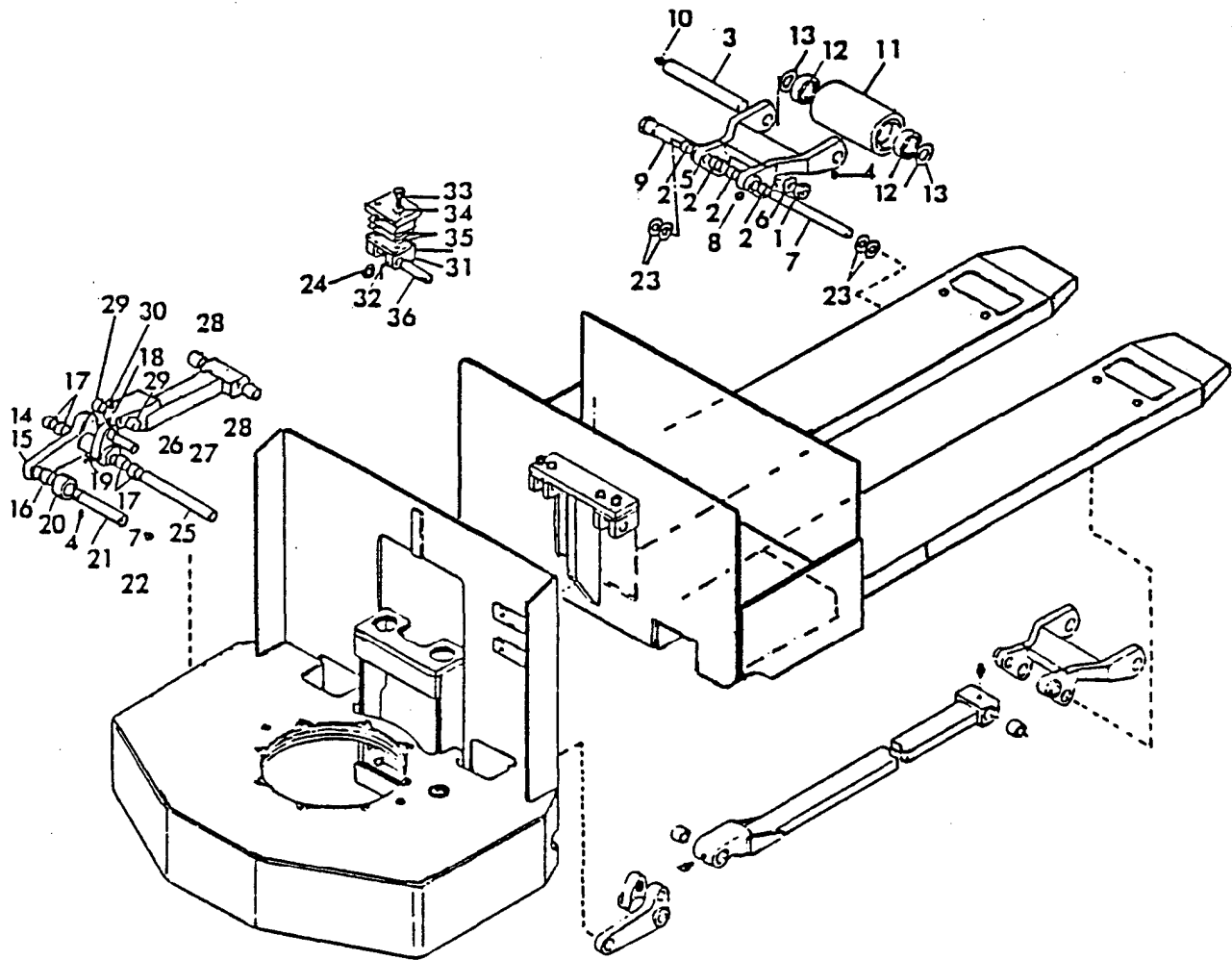

- | | | | |
|-------------------|------------------------|-------------------------|----------------------|
| 1. NUT | 10. GREASE FITTING | 19. GREASE FITTING | 28. BUSHING |
| 2. BUSHING | 11. LOAD WHEEL | 20. SPACER | 29. BUSHING |
| 3. WHEEL SHAFT | 12. BEARING | 21. FRAME LINK SHAFT | 30. GREASE FITTING |
| 4. SET SCREW | 13. WASHER | 22. GREASE FITTING | 31. CYLINDER BRACKET |
| 5. LOAD ARM | 14. ELEVATING LINK (R) | 23. SPACER | 32. SET SCREW |
| 6. LOCK WASHER | 15. ELEVATING LINK (L) | 24. WASHER | 33. BOLT |
| 7. LOAD ARM SHAFT | 16. BUSHING | 25. LINK PULL ROD SHAFT | 34. LOCK WASHER |
| 8. GREASE FITTING | 17. BUSHING | 26. PULL ROD SHAFT | 35. SHIM |
| 9. ECCENTRIC PIN | 18. SET SCREW | 27. PULL ROD ASSY. | 36. CYLINDER PIN |

Figure 5.19 Fork and Linkage

WALKIE: MAINTENANCE

HYDRAULIC MAINTENANCE

Hydraulic Reservoir (Cont'd)

Inspection Every
1,000 Hours (Cont'd)

12. Install the hydraulic unit on the mounting bracket (frame).
13. Install the hydraulic lines on the hydraulic unit.
14. Fill the reservoir with the specified hydraulic oil. Use a funnel with a flexible neck. Fill the reservoir only until oil can be seen at the bottom of the elbow.
15. Connect all wires and cables to the pump motor. Connect the battery.
16. Install the breather cap. Raise and lower the forks and inspect all hoses and fittings for leaks.

NOTE: Make sure that the oil is free of tiny air bubbles which may be seen only under close inspection.

17. Fully lower the forks.
18. Check the hydraulic oil level in the reservoir.
19. Raise and lower the forks to check for leaks.

Lift Cylinders Service

After each 50 hours of operation check the lift cylinder hoses and fittings for leaks. Repair if needed. Check the cylinder mounting. Make sure that the retainer ring at the bottom of the cylinders are tight against the frame. (Refer to Figure 5.25)

Oil Leakage Wiper Seal

Check for oil leakage at the wiper seal. Slight oil leakage at the seal indicates that the wiper seal and/or "O" rings are getting worn. When leakage becomes excessive, disassemble and inspect the complete assembly. Replace any components which are worn or broken. (Refer to Figure 5.25)

NOTE: When reassembling the cylinder, insert the retainer ring (12) thru the slot in the cylinder barrel (4) and into the hole in the cylinder head, then rotate the cylinder head clockwise until the lock ring is in place.

WALKIE: MAINTENANCE

ELECTRICAL MAINTENANCE

ELECTRICAL MAINTENANCE

24 VOLT UNIT

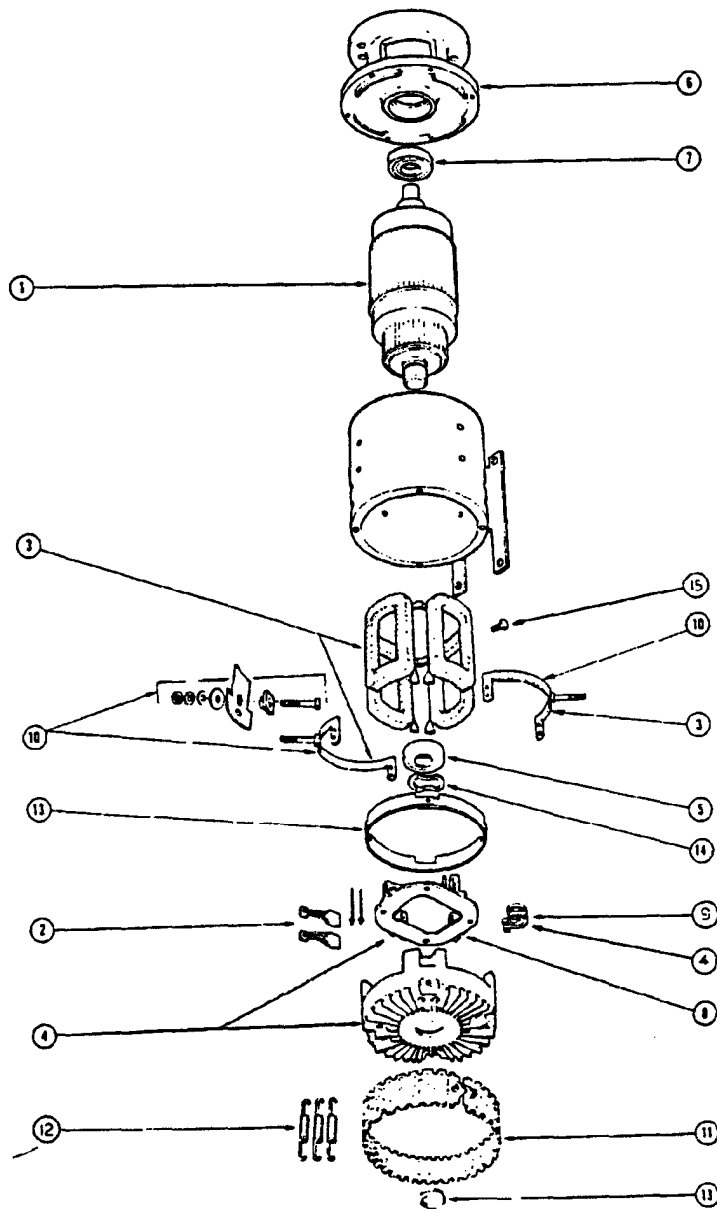

- | | | |
|-------------------------|-------------------------|-----------------------------|
| 1. ARMATURE | 6. DRIVE END HEAD ASSY. | 11. COVER BAND |
| 2. BRUSH SET | 7. DRIVE END BEARING | 12. BAND SPRING PKG. |
| 3. FIELD COIL SET | 8. BRUSH HOLDER SET | 13. COMM. END BEARING COVER |
| 4. COMM. END HEAD ASSY. | 9. BRUSH SPRING SET | 14. COMM. END SPRING WASHER |
| 5. COMM. END BEARING | 10. TERMINAL STUD PKG. | 15. POLE SHOE SCREW PKG. |

Figure 5.30 Drive Unit Motor (Exploded View)

ELECTRICAL MAINTENANCE

- 1. Frame & Core Assembly
- 2. Side Plate
- 3. Side Plate
- 4. Non-Metallic Washer
- 5. Coil
- 6. Front End Plate
- 7. Return Spring
- 8. Movable Core & Rod Assembly
- 9. Top Frame Screw
- 9A. Bottom Frame Screw
- 10. Insulating Clip
- 11. Nut
- 12. Screw
- 13. Switch (Interlock)
- 14. Actuator
- 15. Mounting Plate
- 16. Interlock Kit
- 17. Detent
- 18. Insulation
- 19. Insulation
- 20. Screw
- 21. Insulation
- 22. Stationary Buss Bar
- 23. Screw
- 24. Screw
- 25. Bridge Guide
- 26. Screw
- 27. Washer
- 28. Bushing
- 29. Contact Bar
- 30. Contact Spring
- 31. Bushing
- 32. Non-Metallic Washer
- 33. Nut
- 34. Suppressor Assembly

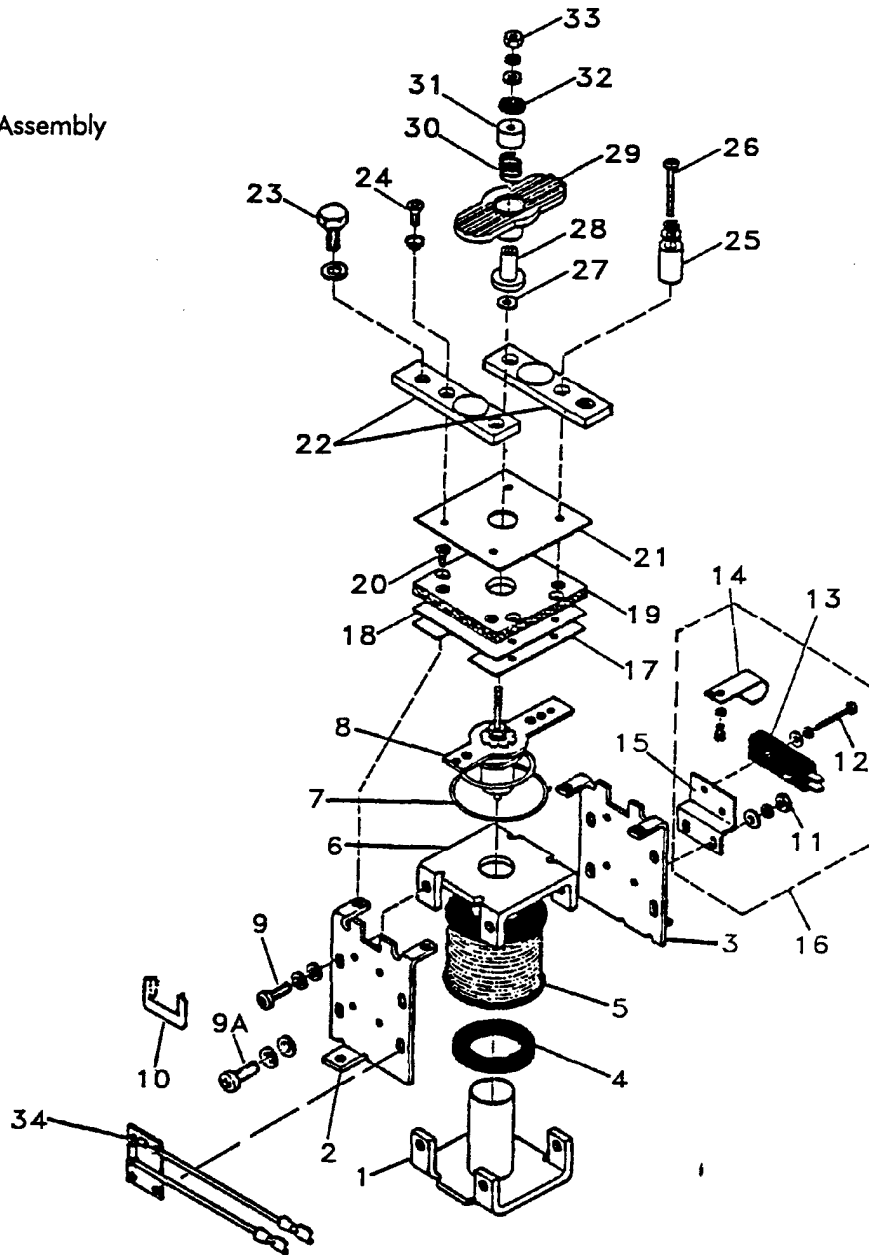

Figure 5.37 Typical Contactor Exploded View

WALKIE: TROUBLESHOOTING

RESISTOR CONTROLS

TEST A

TRUCK DOES NOT RUN

Directional contactors do not close in both directions.

Check Test Point 1 (S1 and S2 - closed).

Correct BV*:

1. Check Test Point 2 (MS1 or MS2 - closed)

Incorrect:

1. Check battery terminals.
2. Check fuses F2 and F3.
3. Check key switch (S1).
4. Check brake switch (S2).

Correct BV:

1. Check contactors M1 and M2.

Incorrect:

1. Check microswitches S25, MS1 and MS2.

TEST B

TRUCK DOES NOT RUN

Directional contactors close simultaneously.

1. Check microswitch MS1 or MS2.
2. Check wiring for shorted condition.

TEST C

TRUCK RUNS IN ONE DIRECTION ONLY

Contactor for one direction does not close.

Check Test Point 2.
S1 and S2 - closed.
MS1 or MS2 - closed.

Correct BV:

1. Check contactors M1 or M2.

Incorrect:

1. Check microswitches MS1, MS2 and S25 .

*BV = Battery Volts as referenced to battery negative.

WALKIE: TROUBLESHOOTING

ADVANCED TRANSISTOR CONTROLS (AT)

TEST G

TRUCK RUNS IN ONE DIRECTION ONLY

Directional contactors (M1 and M2) work normally.

Check test point - 6 .

Check continuity through M1 and M2 contactor tips.

Incorrect:

1. Check contactor tips - Replace.
2. Check contactor buss bars - Replace.

Correct:

0 Ohms.

Check wiring and connections.

WALKIE: TROUBLESHOOTING

COMMON PROBLEMS FOR ALL TRUCKS

COMMON PROBLEMS FOR ALL TRUCKS

- | | | |
|---|-------|---|
| 1. Control handle will NOT return to the Neutral position unassisted. | YES → | Handle needs adjustment. Refer to Chapter 5 for procedure.
Defective spring(s) within the handle. Refer to Chapter 5 for service. |
| 2. Drive wheel bumps and/or very noisy. | YES → | Replace defective drive wheel. Refer to Chapter 5. |
| 3. Load wheels badly worn with excessive breaks or missing sections. | YES → | Replace both load wheels and wheel bearings. Refer to Chapter 5. |
| 4. Casters badly worn, will not turn or caster. | YES → | Replace worn parts as required. Refer to Chapter 5. |
| 5. Drum brake does NOT stop truck travel. | YES → | Check drive motor cut out switch for proper operation.
Adjust drive motor cut out switch if required.
Check brake operation and repair or adjust as required. |

Items below do not apply to:
Model 114-TOW.

- | | | |
|-------------------------------------|-------|---|
| 6. Fork height incorrect or uneven. | YES → | Adjust forks per instructions in Chapter 5.
Check and if required, adjust the lift limit switch per Chapter 5. |
| 7. Hydraulic system leaks. | YES → | Locate defective component and repair or replace as required. Refer to Chapter 5. |

NOTE: Refer to Chapter 5 for all of the above.

END OF CHAPTER

WIRING DIAGRAMS

Wiring Diagram - Model 111-F60L (Resistor)

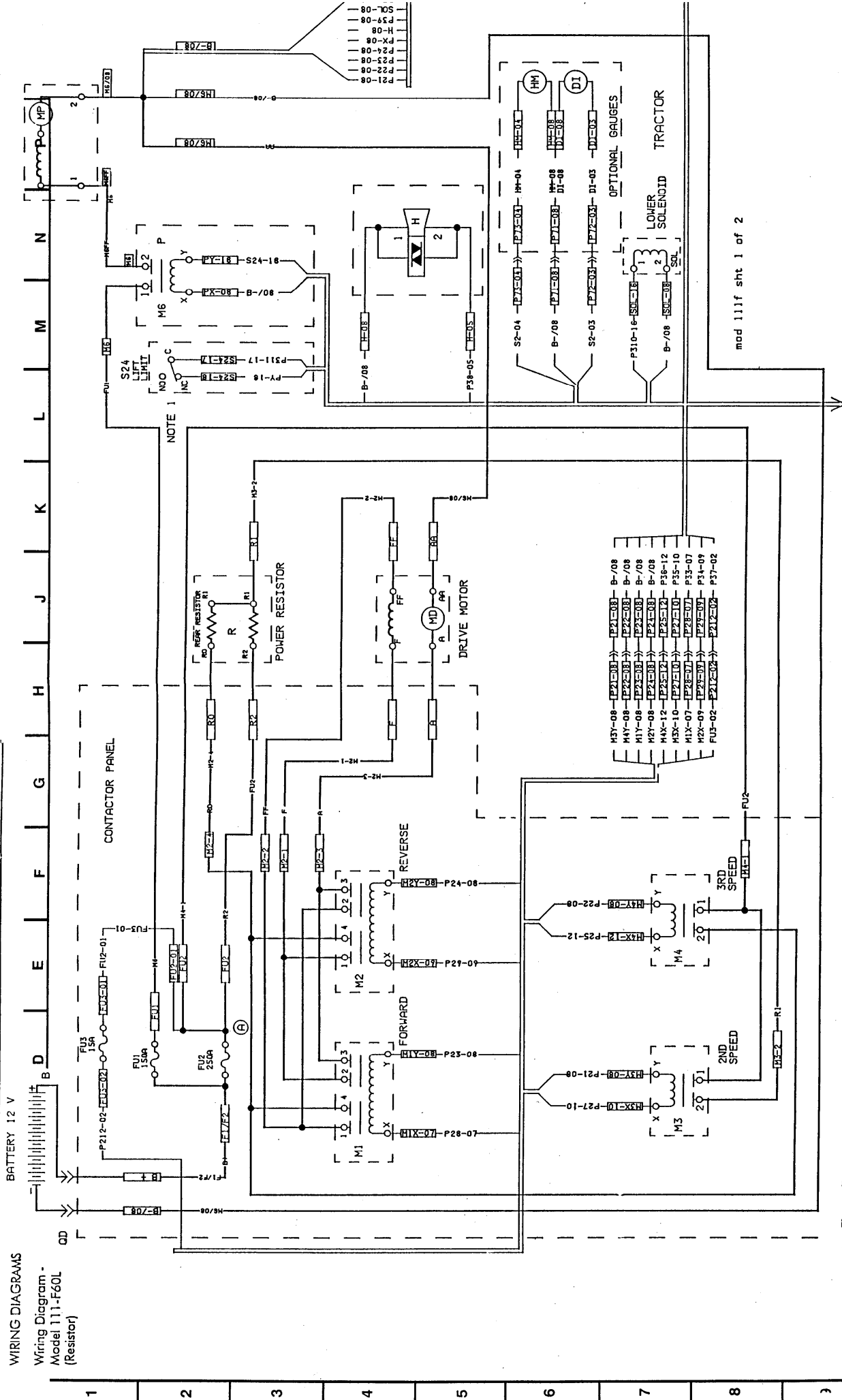

Figure 7.6 Wiring Diagram for Model 111-F60L (Resistor) Sheet 1 of 2

CLICK HERE TO **DOWNLOAD** THE COMPLETE MANUAL

- Thank you very much for reading the preview of the manual.
- You can download the complete manual from: www.heydownloads.com by clicking the link below



- Please note: If there is no response to CLICKING the link, please download this PDF first and then click on it.

CLICK HERE TO **DOWNLOAD** THE COMPLETE MANUAL