

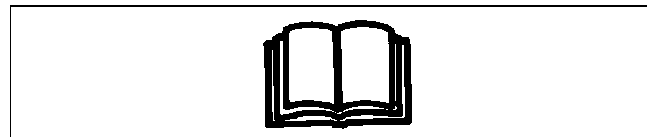

## Safety instructions

	<b>WARNING</b>
<p>Operator must have instructions before running the machine. Untrained operators can cause injury or death.</p>	



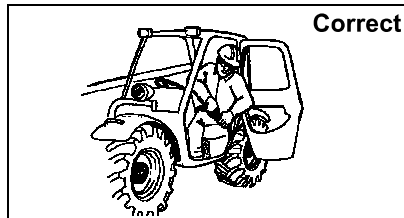

 Never use the telescopic handler without instructions. See the machine signs (decals), Operation & Maintenance Manual, and data sheets located in the cab.

	<p><b>Safety Alert Symbol:</b> This symbol with a warning statement means: "Warning, be alert! Your safety is involved!" Carefully read the message that follows.</p>
---	---

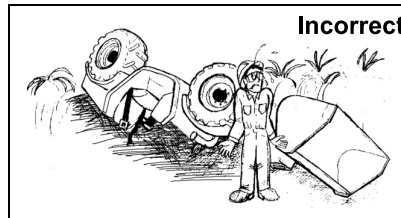

 Always fasten seat belt securely. Do not have any part of your body outside the cab.



 Never use the telescopic handler without operator cab (ROPS & FOPS).

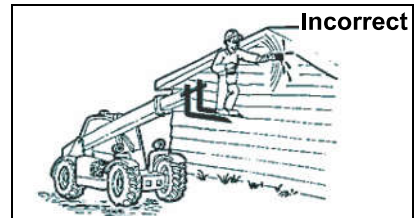

 Never use the machine as a working platform or an elevator.

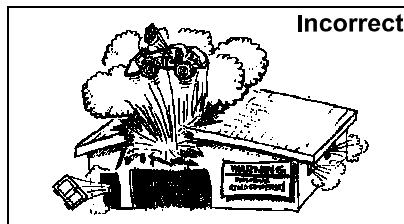

 Do not use the machine where exhaust can contact flammable material, explosive dust or gases.

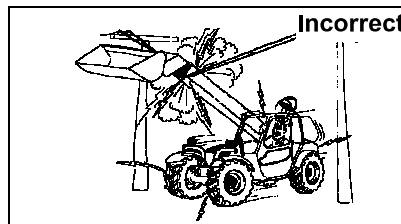

 Check for underground or overhead lines in the area before operating the machine.  
Keep a minimum distance of 8 m between the nearest line and the machine arm, attachment, or load.

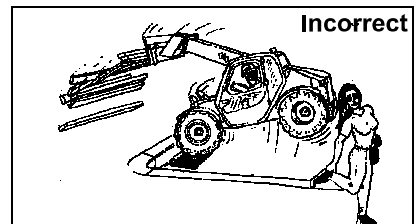

 Never transport a load when raised. Do not travel or turn with the lift arms up. Load, unload and turn on flat level ground.

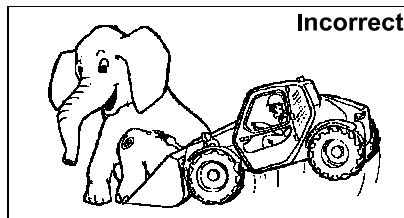

 Never exceed rated operating capacity. Keep to the limits of the machine's load chart and/or the attachment's nominal capacity.

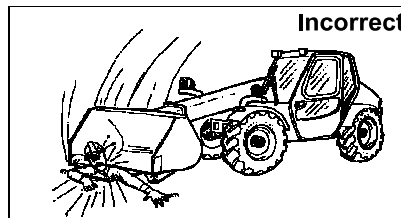

 Never leave telescopic handler with engine running or with lift arms up. To park, engage parking brake and put attachment flat on the ground.

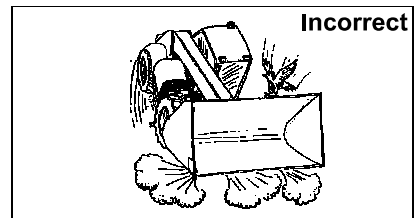

 Never modify equipment. Only use attachments that are approved by Massey Ferguson for this type of telescopic handler.

### SAFETY EQUIPMENT

The Massey Ferguson telescopic handler must be equipped with safety systems necessary for each job. Ask your dealer for information on the safe use of attachments and accessories.

- **SEAT BELT:** Check belt fasteners and check for damaged strap or buckle.
- **OPERATOR CAB (ROPS & FOPS):** It must be on the machine with all fasteners tight. Never use the machine without the right side window.
- **OPERATOR'S HANDBOOK:** Must be in cab.
- **MACHINE SIGNS (Decals):** Replace if Damaged
- **SAFETY TREADS:** Replace if Damaged
- **GRAB HANDLES:** Replace if Damaged
- **PARKING BRAKE**
- **WINDOWS AND MIRRORS:** Clean and check for broken window or mirror. Replace if Damaged

CLICK HERE TO **DOWNLOAD** THE COMPLETE MANUAL

- Thank you very much for reading the preview of the manual.
- You can download the complete manual from: [www.heydownloads.com](http://www.heydownloads.com) by clicking the link below



- Please note: If there is no response to CLICKING the link, please download this PDF first and then click on it.

CLICK HERE TO **DOWNLOAD** THE COMPLETE MANUAL

## Fire Prevention

The machines and some attachments have components that are at high temperatures under normal operating conditions. The primary source of high temperatures is the engine and exhaust system. The electrical system, if damaged or incorrectly maintained, can be a source of arcs or sparks.

- Stop the engine and let it cool before adding fuel. No smoking!
- Use the procedure in the Operation & Maintenance Manual for connecting the battery and for jump starting.
- Know where fire extinguishers and first aid kits are located and how to use them. Replacement fire extinguishers are available from your Massey Ferguson dealer.

## Instructions for maintenance

- Read the maintenance instructions carefully.
- Machine maintenance and compliance are obligatory.
- For any intervention other than normal maintenance, consult your Massey Ferguson dealer.
- Clean the machine or at least the relevant area before any maintenance work. Protect against water, steam or cleaning agents any components likely to be damaged (particularly electric components) during this operation.
- Only wear suitable clothing, avoid loose clothing. Tie back and protect your hair, if necessary.
- Turn off the engine before any maintenance work. If any maintenance work requires the engine to be running, take all the necessary safety measures and precautions. There may be moving parts, high temperatures, hydraulic circuits under pressure, electric circuits under voltage. Such operations must be carried out by trained, qualified personnel.
- Make sure that the area is adequately ventilated before starting the engine.
- Clean up all traces of fuel, oil, grease or impurities.
- Make any necessary repairs immediately even if they do not seem important.
- Immediately repair any leaks, even if they do not seem important.
- Do not run the engine without complete fuel and exhaust systems, without oil or coolant, or in case of fuel leaks.
- Do not operate the machine without hydraulic fluid in the hydraulic system.
- Use only recommended lubricants. Do not use polluted lubricants or lubricants whose filtration state is not precisely known.
- Wait until the engine coolant has dropped to a temperature of less than 20°C before opening the surge tank plug or carrying out work on the engine cooling system.
- Do not take apart, tighten or loosen any connections, hoses or any hydraulic component when the system is under pressure. Such operations must be carried out by trained, qualified personnel.
- Do not smoke or approach the machine with a bare flame if the fuel tank is open or when filling it. Fill the tank in a suitable place. Do not fill the tank while the engine is running.

**Multi-function dial**

This multi-function dial comprises 16 lights and 5 indicators. The indicator lights are visible only when they are on. The indicators are lighted when the side-lights are on.

**Figure 11**

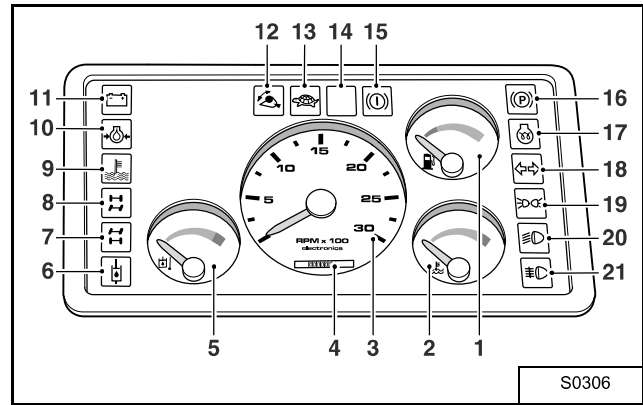

Reference	Icon	Description	Function
1		<b>Fuel gauge</b>	Shows the fuel level.
2		<b>Engine coolant temperature gauge</b>	Shows the temperature of the engine coolant in the thermostat box. The beginning of the red zone corresponds to a temperature of 103°C. <b>If the meter hand reaches the red zone, turn the engine off immediately and find out the reasons for this abnormal operating temperature. Consult your Massey Ferguson dealer.</b>
3		<b>RPM counter</b>	Shows the diesel engine's RPM.
4		<b>Hourmeter</b>	Shows the total operating hours of the machine. Use these indicators for planning and carrying out maintenance operations.
5		<b>Hydraulic oil temperature gauge</b>	Shows the temperature of hydraulic oil in the tank. The beginning of the red zone corresponds to a temperature of 95°C. <b>If the meter hand reaches the red zone, turn the engine off immediately and find out the reasons for this abnormal operating temperature. Consult your Massey Ferguson dealer.</b>
6		<b>Hydraulic oil temperature indicator light</b>	Red indicator light with symbol. Lights up when the oil temperature in the tank reaches 95°C. <b>If this indicator light comes on, turn the engine off immediately and find out the reasons for this abnormal operating temperature. Consult your Massey Ferguson dealer.</b>
7		<b>Rear wheel alignment indicator light</b>	Green indicator light with symbol. Comes on when the rear wheels are parallel to the machine's longitudinal axis.
8		<b>Front wheel alignment indicator light</b>	Green indicator light with symbol. Comes on when the front wheels are parallel to the machine's longitudinal axis.
9		<b>Engine coolant temperature indicator light</b>	Red indicator light with symbol. This light comes on when the coolant temperature in the thermostat box reaches 103°C. <b>If this indicator light comes on, turn the engine off immediately and find out the reasons for this abnormal operating temperature. Consult your Massey Ferguson dealer.</b>
10		<b>Engine oil pressure indicator light</b>	Red indicator light with symbol. This light comes on when the lubricating oil pressure in the engine's oil gallery is 0.6 bar. Under normal operation, this indicator light must be: <ul style="list-style-type: none"> <li>• off when the engine is running;</li> <li>• on whenever the ignition switch is on "RUN", "PREHEAT" or "START" and until the engine runs on its own.</li> </ul> <b>If this indicator light comes on, turn the engine off immediately and find out the reasons for this abnormal operating pressure. Consult your Massey Ferguson dealer.</b>

**Left window**

This window is located on the door of the cab and opens 180°.

Opening or closing the window: turn the lever up or down [Figure 28].

Figure 28

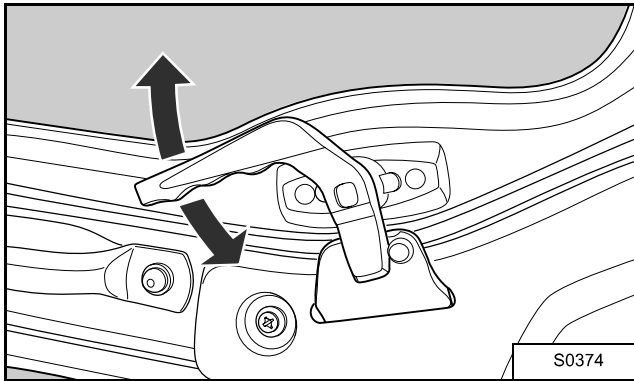

To lock in open position: engage and lock the latch [Figure 29].

Figure 29

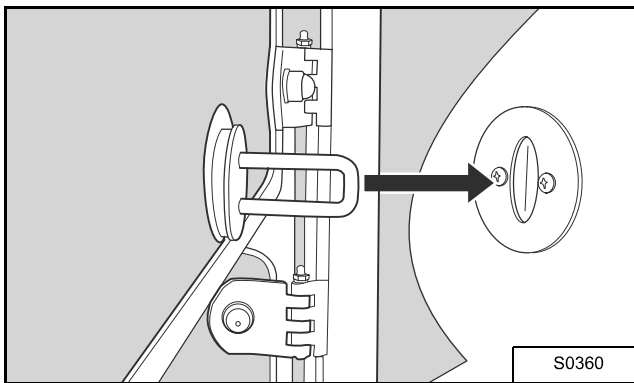

To unlock: turn the lever inside the cab [Figure 30].

Figure 30

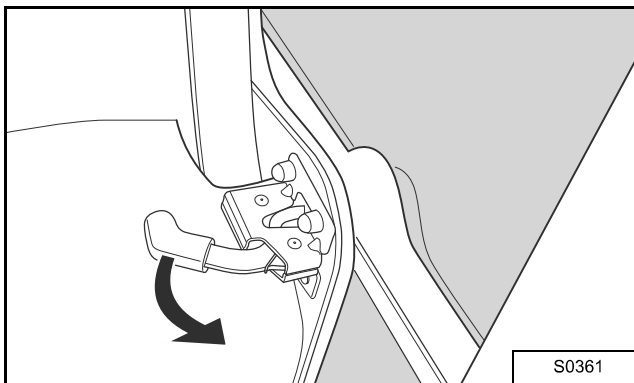

**Circuit breaker**

This circuit breaker (rotary switch with key) is located behind the cab on the left side of the frame. It controls the opening and closing of the ground circuit line between the battery's negative terminal and the frame.

Figure 31

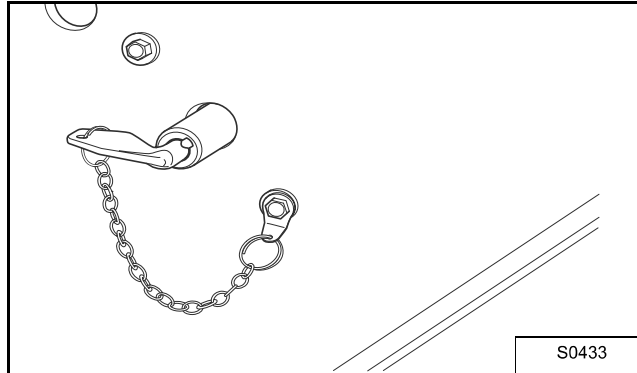

Closing the circuit: insert the key in the switch then turn clockwise until indexing.

Opening the circuit: turn the key counterclockwise then remove it from the switch.

**⚠ WARNING**

**When the engine is running, only open the circuit when absolutely necessary.**

**It is recommended to open the circuit when the machine is stopped for a long period.**

## Driving on public roads

### Warning

The driver must respect the Highway Code when driving the machine on a public road.

The machine must comply with the Highway Code when being driven on a public road.

Before driving the machine on a public road:

1. Install the rotating beacon and make sure that it is working properly.
2. Make sure that the lights and signals are in good condition, are clean and are working properly.
3. Make sure that the windows are clean and that the windscreen washer and wiper are working properly.
4. Make sure that the tyres are properly inflated and that they are not covered with mud, stones or any other impurity.
5. Check the fuel level.
6. Check the rear view mirrors are correctly adjusted.
7. Move the boom to the transport position:
  - telescope fully retracted
  - attachment tilted fully backwards
  - attachment 300 mm above ground-level

 **WARNING**

**The transport of loads is prohibited on public roads. When driving on public roads, attachments that can be fitted to the machine must:**

- **either be fitted with appropriate signs and safety devices**
- **or be removed from the machine**

### Driving in some countries

Before marketing this machine in some countries, Massey Ferguson had to obtain road approval so that it can be driven on public roads. New machines are therefore fitted with special devices and attachments. Make sure you use them or install them before driving on a public road. Take care also to keep them in good working order. Driving on public roads also imposes certain conditions on the machine. Please contact us for further details, if necessary.

## Electrical System

### Description

The telescopic handler has a 12 volt, negative ground alternator charging system.

The electrical system is protected by fuses located in the cab on the right hand side console and those located in the engine compartment. The fuses will protect the electrical system when there is an electrical overload. The reason for the overload must be found before starting the engine again.

### Checking the battery fluid level

Figure 77

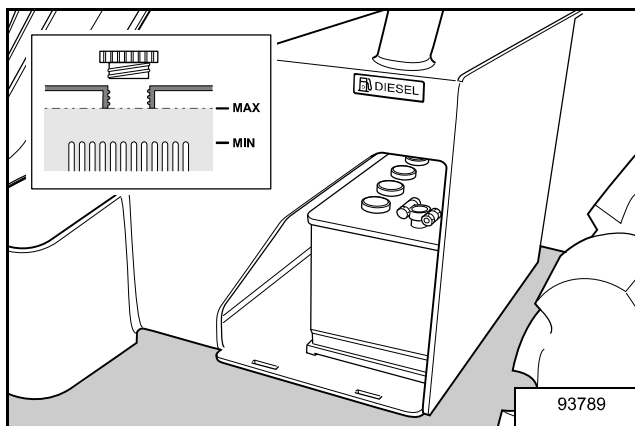

1. Use the cab key to open the battery compartment.
2. Unscrew and remove the caps from the battery cells.
3. To check the level of the liquid: use a small mirror and an electric torch, or remove the battery from the compartment.
4. Top up if necessary by adding distilled water up to the lower edge of the inner tube (see detail on [Figure 77]).

#### IMPORTANT

Use only distilled water to top up the fluid level.

The level of liquid should not exceed the top of the internal elements.



#### WARNING

The battery contains acid.

### Checking the condition of fuses, diodes and relays

The purpose of this operation is to keep the machine properly maintained and to prevent possible damage or accidents. See “Fuses, diodes and relay drawing” on page 49.



#### WARNING

Replace any faulty fuse, diode or relay immediately even if the function that it protects does not seem important. This applies even over and above the recommended frequency.

The fuse box is located beside the seat, under the cover indicated on [Figure 78].

Figure 78

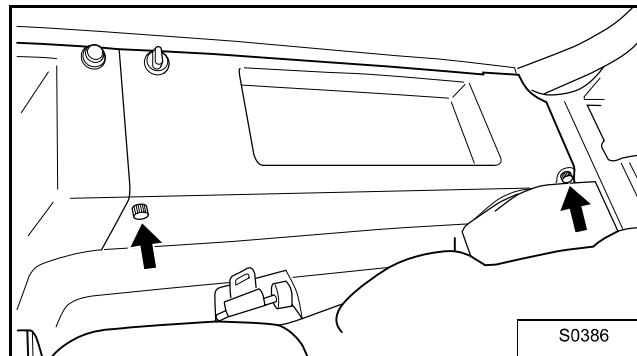

The two fuses and relay for engine preheating and starting are located in the engine compartment, as indicated in the lower part of [Figure 79].

### Checking the working order of controls, lighting and signalling

The purpose of this operation is to keep the machine properly maintained and to prevent possible damage or accidents.



#### WARNING

Replace or repair immediately any faulty component even if its function does not seem “important”. This applies even over and above the recommended frequency.

### Checking the condition of electric connections

The purpose of this operation is to keep the machine properly maintained and to prevent possible damage or accidents.

**Operation**

1. Drive the machine forward, with the telescope fully retracted, so that the hook-up is less than 1 m from the attachment and perpendicular to it.
2. Engage the parking brake and put the transmission lever into neutral.
3. Remove the locking bar safety pin, and remove the bar and place it near the machine.

Figure 99

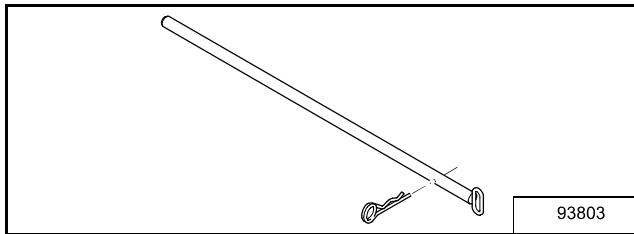

4. Tilt the hook-up forwards so that the hooks are lower than the attachment pipe (1) [Figure 100].

Figure 100

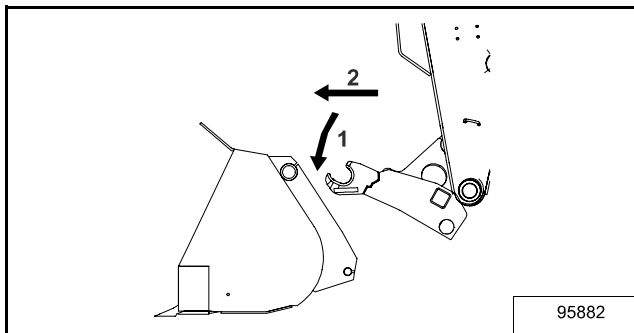

5. Extend the telescope so that the hooks are right below the attachments pipe (2) [Figure 100].
6. Raise the boom in order to engage the attachment pipe in the hooks; tilt the hook-up if necessary (3) [Figure 101].

Figure 101

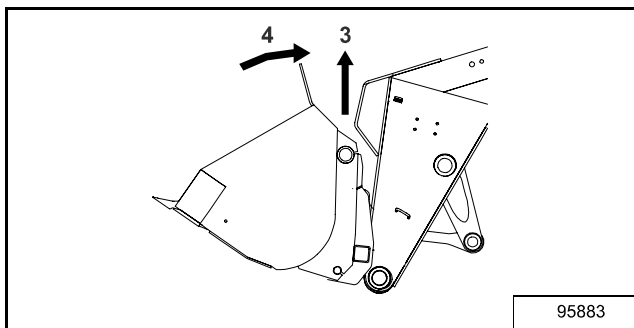

7. When the pipe is properly engaged in the 2 hooks and the attachment is no longer touching the ground, tilt the bracket fully backwards (4) [Figure 101].
8. Reinstall the locking bar and its safety pin.



**WARNING**

**Never operate the machine if the locking bar and its safety pin are not reinstalled properly.**

**Hydraulic lock**

**Description**

The hook-up includes the following:

- two hooks on top.
- A locking bar on each side at the bottom. These bars are kept in place by spring locks. A hydraulic cylinder with two feed hoses retracts the two bars in order to unlock the attachment.

Figure 102

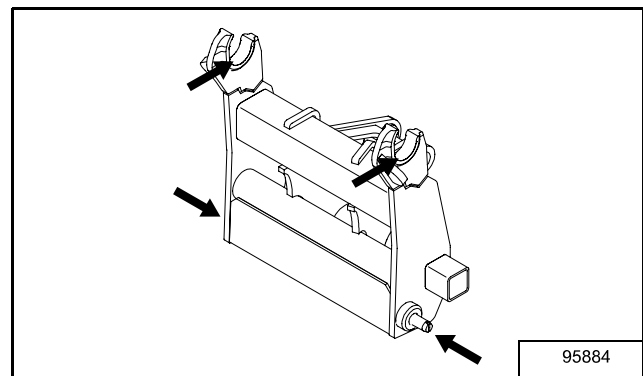

Each attachment includes the following:

- A pipe on top.
- Two bores below.

Figure 103

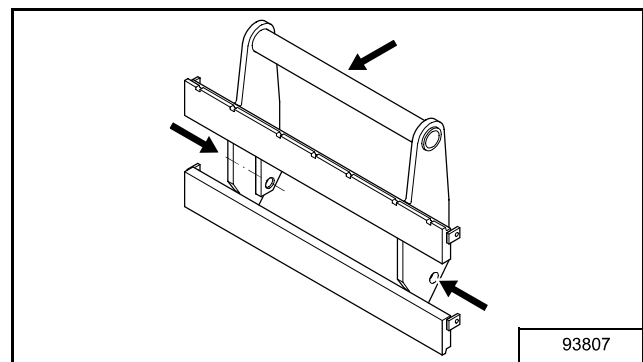

**Tyres**

**WARNING**

- **Observe the load charts for each set of tyres.**
- **Only use the tyres listed below, use of other tyres may cause accidents.**
- **The machine must be fitted with the same 4 tyres.**
- **Observe the recommended tyre pressures.**
- **Replace any tyre showing signs of deterioration immediately.**

**Tyres for 8947**

Four sets are available:

Brand	Dimensions	Pressure (bar)
TITAN (Option)	400/70 - 20 150B 166A2 LIFT RIGGER II	4
DUNLOP (option)	405/70 - 20 MPT 152J 168A2 SP T9	5.5
DUNLOP (option)	400/70 - 20 150B T37 TL	4
DUNLOP (Standard)	400/80 - 24 153B T37 TL	4.25

These tyres are suitable for use on unprepared ground. Tyre pressure is the same at front and rear.

**Cab Air Conditioning**

**Description**

Air conditioning for the cab includes the following:

- the compressor installed in the engine compartment;
- the condenser installed in the engine compartment;
- the evaporator installed behind the seat in the cab.

*Figure 130*

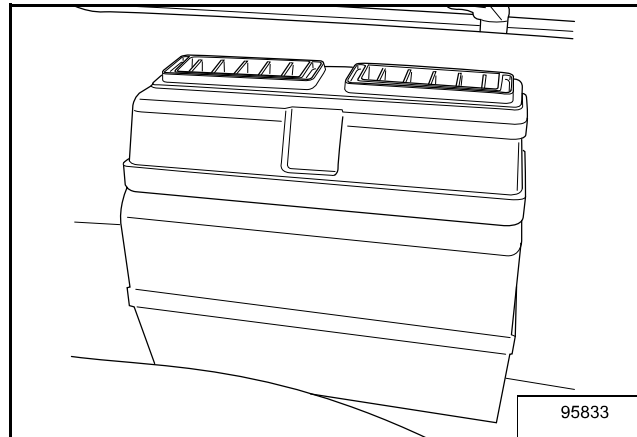

**Operation**

The operator can access the following controls:

- vents;
- fan control switch;
- power switch.

**Vents**

Two adjustable vents are fitted on the upper side of the evaporator and direct the air flow towards the desired direction.

*Figure 131*

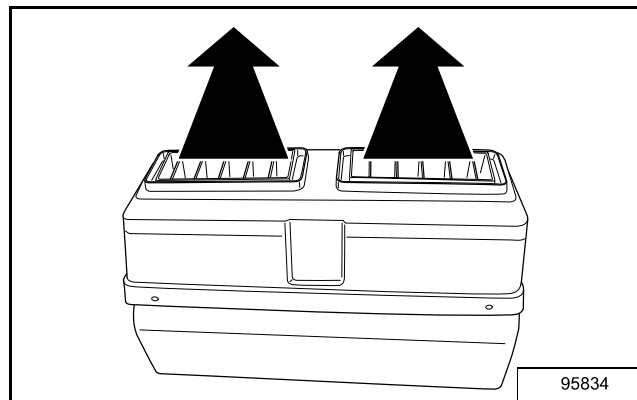

CLICK HERE TO **DOWNLOAD** THE COMPLETE MANUAL

- Thank you very much for reading the preview of the manual.
- You can download the complete manual from: [www.heydownloads.com](http://www.heydownloads.com) by clicking the link below



- Please note: If there is no response to CLICKING the link, please download this PDF first and then click on it.

CLICK HERE TO **DOWNLOAD** THE COMPLETE MANUAL