

Operation and Maintenance Manual

R 964

Litronic

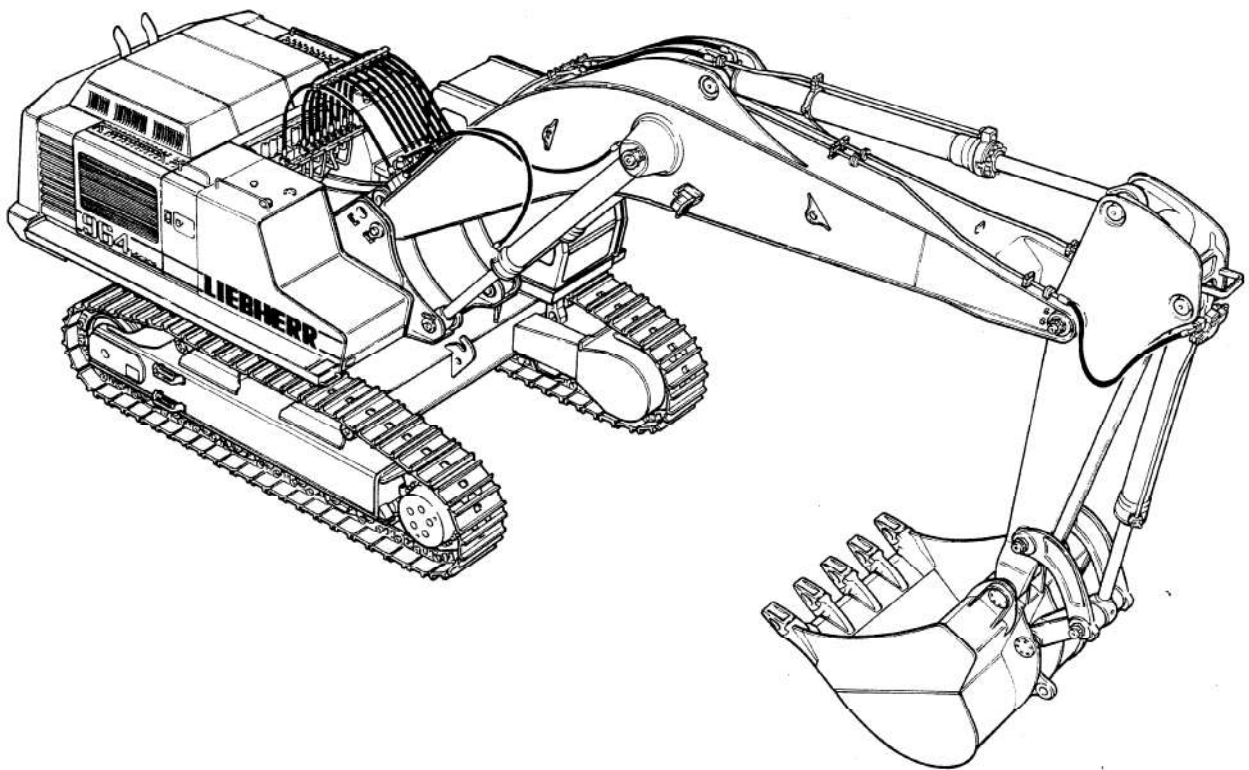

CLICK HERE TO **DOWNLOAD** THE COMPLETE MANUAL

- Thank you very much for reading the preview of the manual.
- You can download the complete manual from: www.heydownloads.com by clicking the link below



- Please note: If there is no response to CLICKING the link, please download this PDF first and then click on it.

CLICK HERE TO **DOWNLOAD** THE COMPLETE MANUAL

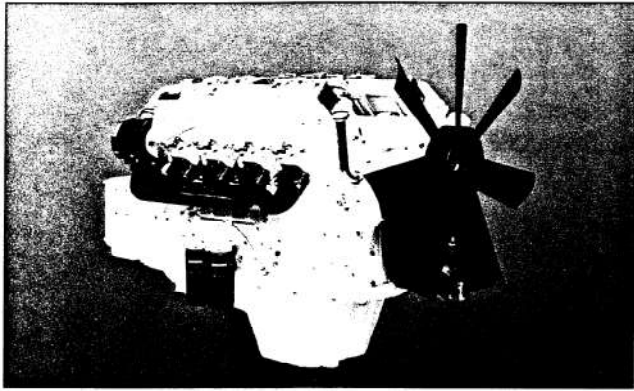

Diesel Engine

The heavy duty, liquid cooled, turbo-charged Liebherr diesel engine, specifically designed for construction machines, delivers superior power and long service life. Its low engine speed results in reduced fuel consumption, low emissions and extended reliability. Highly dependable and maintenance-free gear drive for cooling fan, water pump and auxiliary hydraulic pumps eliminates V-belts. All service points are located on one side of the engine for easy access and reduced maintenance effort.

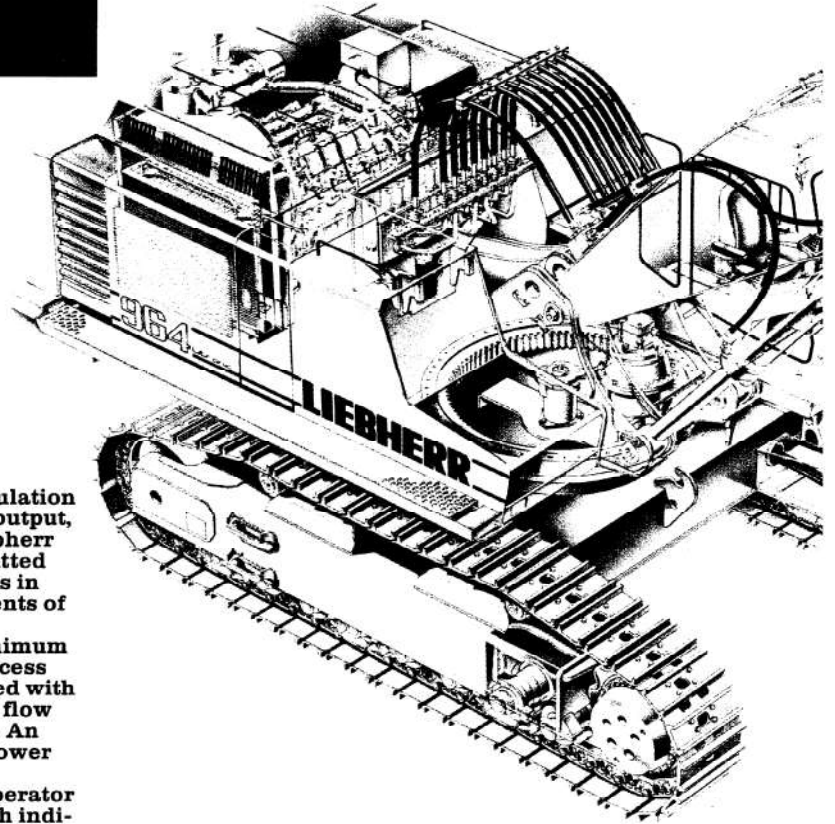

Litronic System

The electronic engine-speed-sensing pump regulation allows full utilization of the engine's available output, independent from external influences. The Liebherr variable displacement axial piston pumps are fitted with an electro-hydraulic regulator which reacts in fractions of a second to the changing requirements of power or speed.

Flow compensation reduces pump flow to a minimum when joystick levers are in neutral, avoiding excess heat and energy loss. The same effect is achieved with pressure compensation which minimizes pump flow prior to reaching maximum operating pressure. An automatic oil flow optimizer assures efficient power distribution to each individual function.

The Liebherr-ECO-control system allows the operator to preselect the machine's performance to match individual application requirements, resulting in significant fuel savings and reduced emissions.

The operator's comfort and efficiency is enhanced by the multicolored LCD display and monitoring system. It monitors all vital machine functions, includes automatic safety features and a diagnostic system.

The Litronic system offers extensive customer benefits, such as improved efficiency, reduced fuel consumption and overall economy.

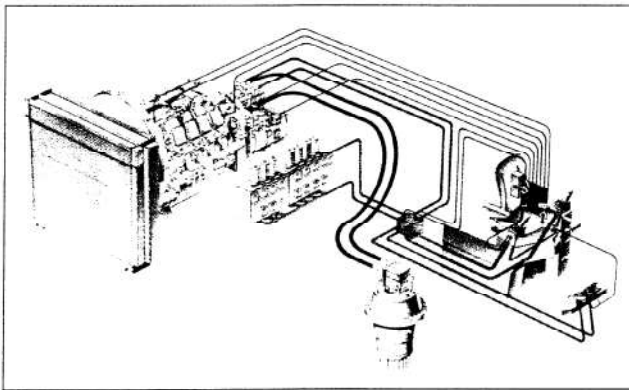

Undercarriage

An overall low center of gravity for the machine is achieved through favorable weight, distribution of the machines undercarriage, upper structure and attachment. This low center of gravity, combined with a wide undercarriage base, provides excellent stability in all operating conditions.

The compact final drives, each consisting of a Liebherr axial piston motor, a Liebherr planetary reduction gear and hydraulic lines, are integrated within the track frame for maximum protection.

More Benefits Through Advanced Techn

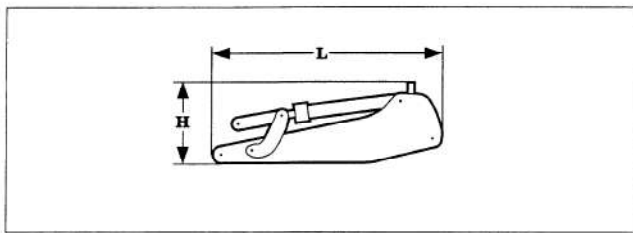

Stick with bucket cylinder

Stick length	m	2,60	3,40	4,20	5,00
L Length	mm	3850	4650	5450	6250
H Height	mm	1350	1350	1100	1100
Width	mm	700	700	700	700
Weight	kg	2600	2700	2950	3100

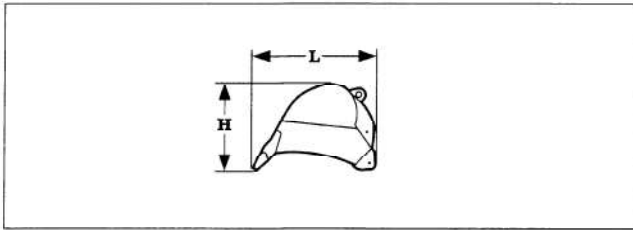

Backhoe buckets

Cutting width	mm	1050	1250	1250	1450	1450	1650	1650
Capacity	m ³	1,40	1,60	1,80	2,00	2,20	2,40	2,60
L Length	mm	2150	2050	2150	2050	2150	2050	2150
H Height	mm	1550	1550	1550	1550	1550	1550	1550
Width	mm	1050	1250	1250	1450	1450	1650	1650
Weight	kg	1850	2250	1950	2580	2200	2800	2400

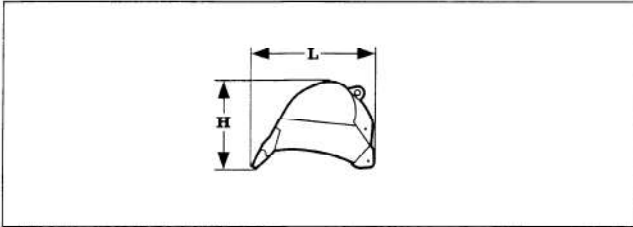

Backhoe buckets

Cutting width	mm	1850	1850	2050	2050	2300	2450
Capacity	m ³	2,80	3,00	3,20	3,50	4,00	5,00
L Length	mm	2050	2150	2050	2150	2200	2200
H Height	mm	1550	1550	1550	1550	1550	1600
Width	mm	1850	1850	2050	2050	2300	2450
Weight	kg	3050	2600	3280	2780	2930	3150

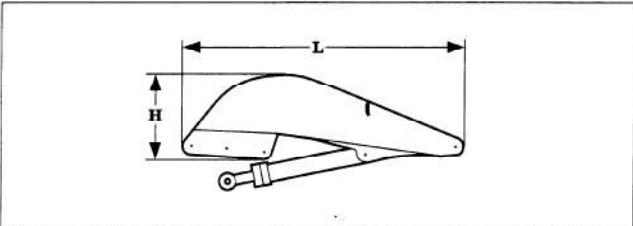

Shovel boom

L Length	mm	4800
H Height	mm	1500
Width	mm	1300
Weight	kg without crowd cylinder	4200
Weight	kg crowd cylinder	600

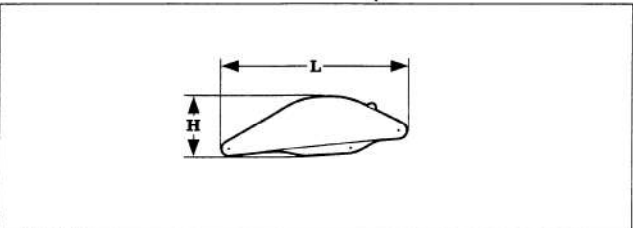

Shovel stick

L Length	mm	3250
H Height	mm	1100
Width	mm	1150
Weight	kg	2200

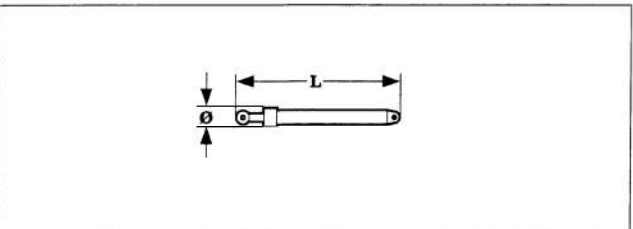

Shovel bucket cylinder (two)

L Length	mm	2550
Ø Diameter	mm	260
Weight	kg	2 x 530

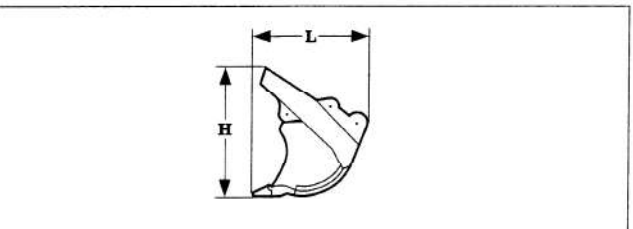

Bottom dump buckets

Cutting width	mm	2250	2500	2500	2750
Capacity	m ³	3,00	3,80	4,20	5,60
L Length	mm	2200	2200	2350	2450
H Height	mm	2200	2200	2350	2450
Width	mm	2250	2500	2500	2750
Weight	kg	-	5200	5600	5600
Wear kit level I		-	5200	5600	5600
Wear kit level II		5200	5650	-	-
Wear kit level III		5900	-	-	-

Components Dimensions and Weights

- Never work underneath the machine if it is raised or propped up with the attachment. The undercarriage must be supported with wooden blocks and supports.
- Always support the raised machine in such a way that any shifting to the weight change will not influence the stability. Do not support the machine with metal on metal support.
- Only qualified, especially trained personnel may work on travel gear, brake and steering systems.
- If it becomes necessary that the machine must be repaired on a grade, block the chains with wedges and secure the uppercarriage to the undercarriage with the lock pin.
- Only qualified, especially trained personnel may work on the hydraulic system.
- Never check for leaks with your bare hands, always wear gloves. Fluid escaping from a small hole can have enough force to penetrate the skin.
- Never loosen or remove lines or fittings before the attachment has been lowered to the ground and the engine has been turned off. Then turn the ignition key to contact position, move all servo controls (joysticks and foot pedals) in both direction to release pressures. Then release the tank pressure as outlined in this Operation and Maintenance Manual.
- Check all lines, hoses and screw connections regularly for leaks and externally visible damage. Fix any damage immediately. Oil escaping from fittings etc. can cause serious injury and fires.
- Before any repairs, always relieve pressures before opening up any system sections and pressure lines (hydraulic lines and air pressure lines).
- Always route and install hydraulic and air pressure lines properly. Do not interchange the connections. The length and quality of hoses must match specifications and requirements.
- Change all hydraulic hoses in specified or appropriate time intervals, even though no damage or defects are visible.
- Always disconnect the battery cable before working on the electrical system or before any arc welding on the machine. Always disconnect the negative (-) cable first and reconnect it last.
- Check the electrical system regularly. Make sure that any problems, such as loose connections, burnt out fuses and bulbs, scorched or chafed cables are fixed immediately by an electrician or qualified personnel.
- Use only Original fuses with the specified amperage. Never use a different size or stronger fuse than the original fuse.
- On machines with electrical medium or high voltage systems:
 - If there is any problem with the electrical energy supply, turn the machine off immediately.
 - Any work on the electrical system may only be performed by a qualified electrician or qualified personnel under the guidance and supervision of an electrician, according to electro - technical regulations.
- If any work is required on any parts which carry current, use a second person to turn off the main battery switch, if necessary. Rope the work area off with a red and white safety rope or chain, and set up warning signs. Use only insulated tools.
- When working on medium and high voltage components, shut off the voltage and connect the supply cable to the ground and ground the components, such as the condensor, with a grounding rod.
- Check all disconnected parts if they are truly free of current, ground them and close them off quickly. Insulate any close-by, current carrying parts.

DIESEL ENGINE OPERATION

IGNITION KEY POSITIONS (Fig. 9).

- 0- Off
- 1- Contact position
- 2- Preheat (must be hold in position)
- 3- Start

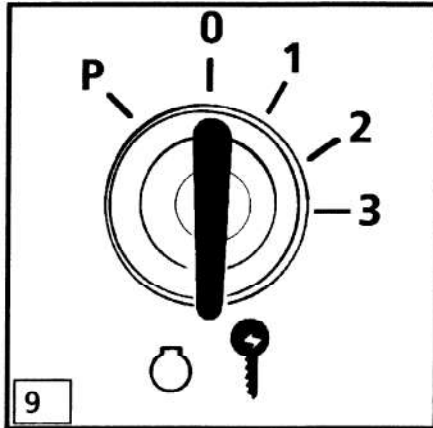

ENGINE SPEED CONTROL LEVER (THROTTLE CONTROL LEVER) :

The speed control lever (Fig. 10, pos. 14) makes it possible to adjust the engine speed to any desired value within the whole RPM range.

The arrow (Fig. 12, pos. 61) on the indicator light lights up, when the engine is running in the ECO-speed range. In this range, the engine runs at somewhat reduced speed and output at utmost fuel efficiency.

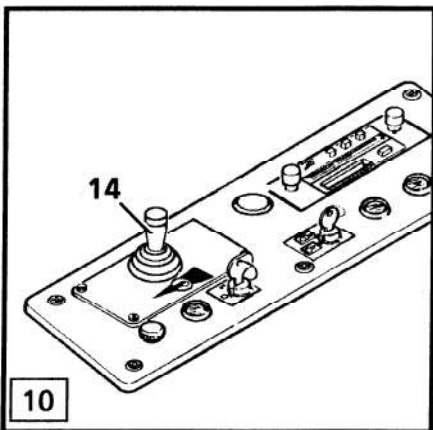

TO ENERGIZE THE ELECTRICAL SYSTEM

Turn the key to pos. 1 .
Check the function of the indicator lights (Fig. 12).

Make sure that all indicator lights and gauges work, this means indicator lights 61 and 70 to 82 should light up about 3 seconds and at the same time, indicators 55 to 58 should actuate.

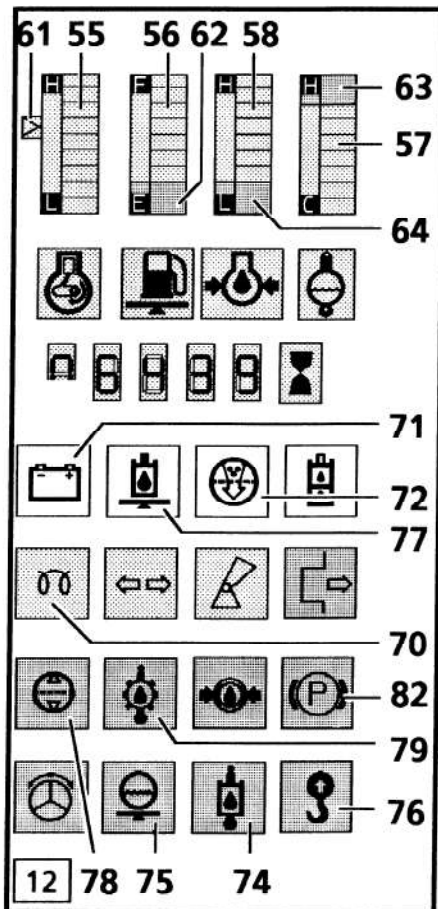

STARTING THE ENGINE AT AMBIENT TEMPERATURES TO -12° C (10° F)

- Increase the engine RPM a little via control lever 14 (fig. 10).
 - Turn the ignition key to starting position 3.
- If the ignition key is longer than 10 seconds in position 1, return the key to 0 position before turning to position 3, or current flow to the starter will be interrupted.
- As soon as the engine is running, release the key and lower the engine RPM.

The engine can not be cranked for more than 10 seconds !

If the engine does not start, repeat the starting procedure at one minute intervals to allow the starter motor to cool off.

STARTING THE ENGINE WITH FLAME GLOW PLUG AT AMBIENT TEMPERATURES BELOW -12° C (10° F)

Starting the engine with the flame glow plug improves starting the engine at low temperatures.

Slightly increase the engine RPM via throttle control lever 14 (Fig. 10).

CLICK HERE TO **DOWNLOAD** THE COMPLETE MANUAL

- Thank you very much for reading the preview of the manual.
- You can download the complete manual from: www.heydownloads.com by clicking the link below



- Please note: If there is no response to CLICKING the link, please download this PDF first and then click on it.

CLICK HERE TO **DOWNLOAD** THE COMPLETE MANUAL

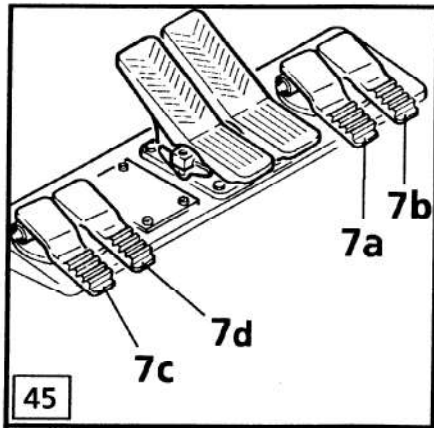

CONTROL OF HYDRAULIC HAMMER
(optional equipment)

The hydraulic hammer is actuated via the pedal either 7c or 7d of the left pilot control (fig. 45).

Notice :

Before using an hydraulic hammer, the three way valve 8 (fig. 52) must be turned to position B and the key switch 93 on the rear control desk must be switched to the position "hammer".

After removing the hydraulic hammer and before using the cylinder of the special equipment, turn the three way valve 8 to position A and the key switch 93 to position "cylinder".

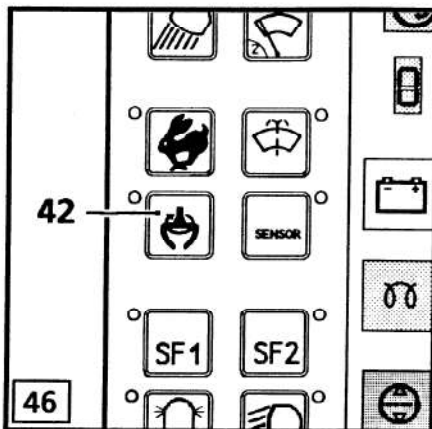

CONTROL OF A ROTATING GRAPPLE
(optional equipment)

The hydraulically rotating grapple is controlled via a solenoid valve using a separate hydraulic circuit.

To actuate this added attachment, switch 42 is used.

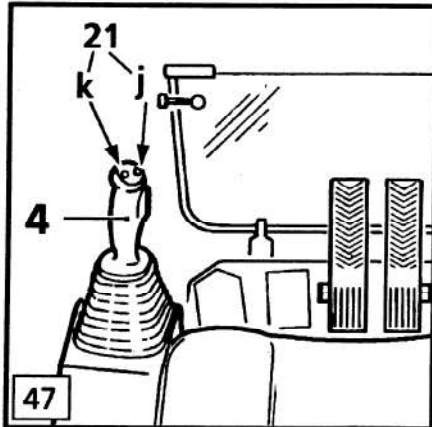

The grapple rotation is controlled via the both push buttons 21 in the left joystick handle 4. *

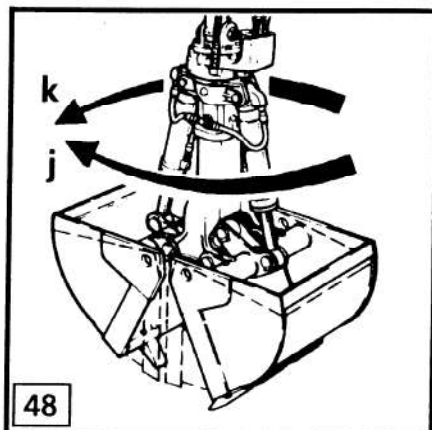

If the right button 21J is pushed, the grapple will rotate clockwise.

If the left button 21K is pushed, the grapple turns counterclockwise.

The grapple rotates until the buttons are released.

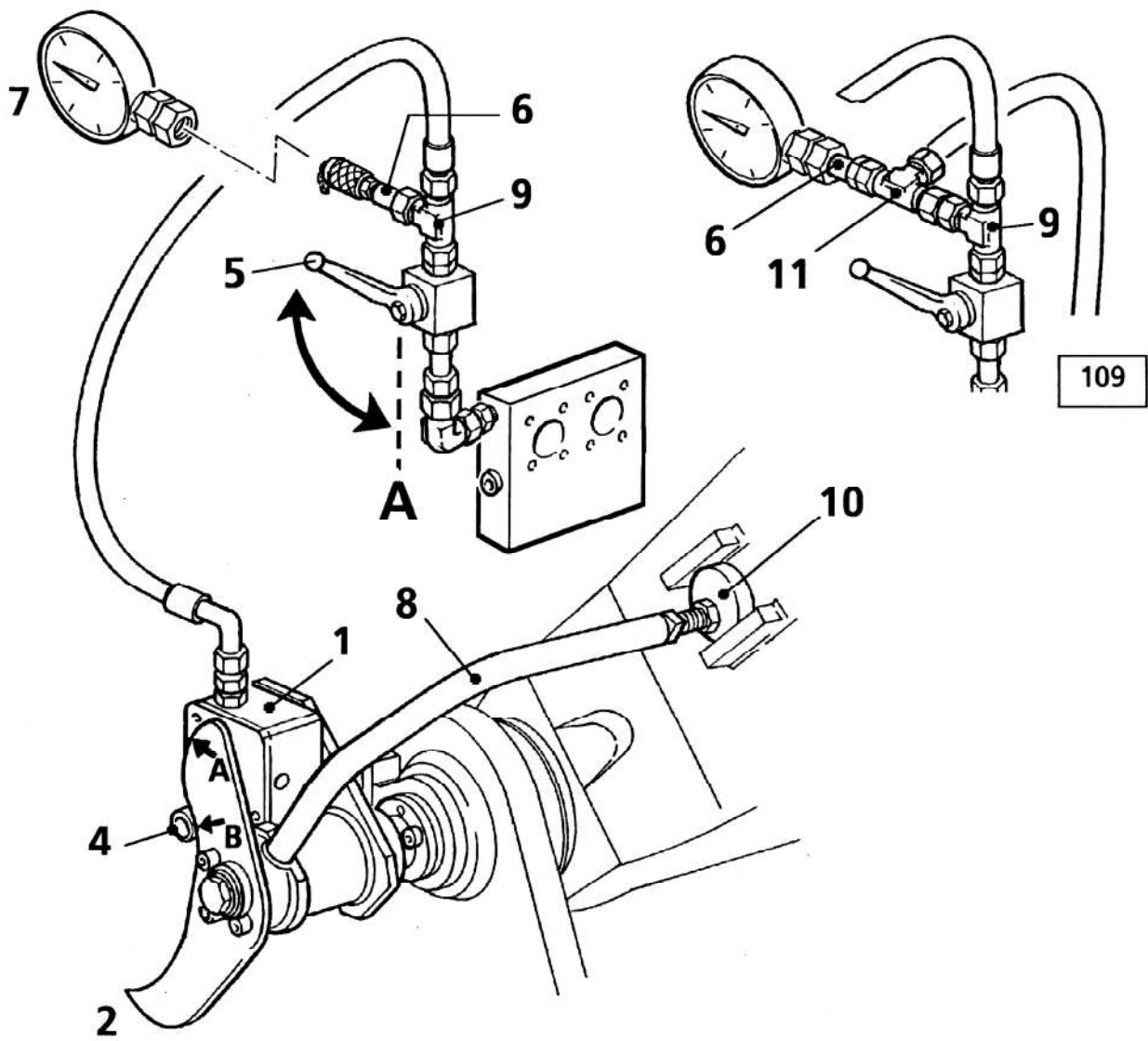

110

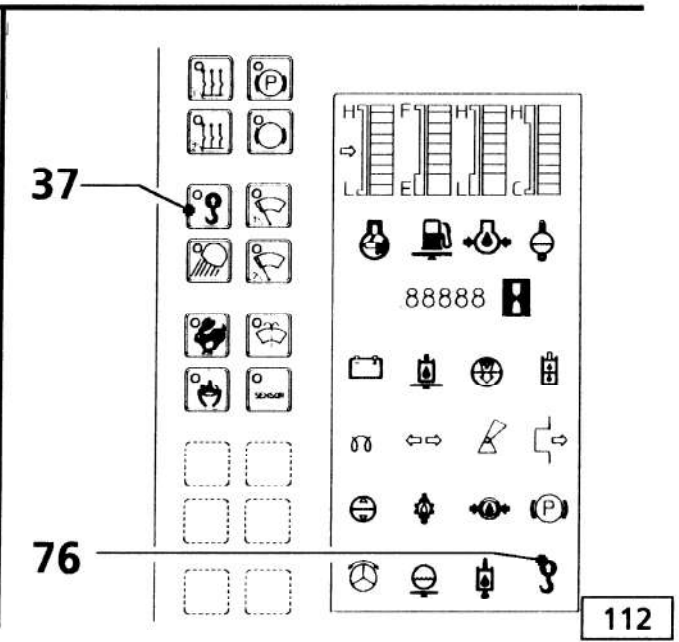
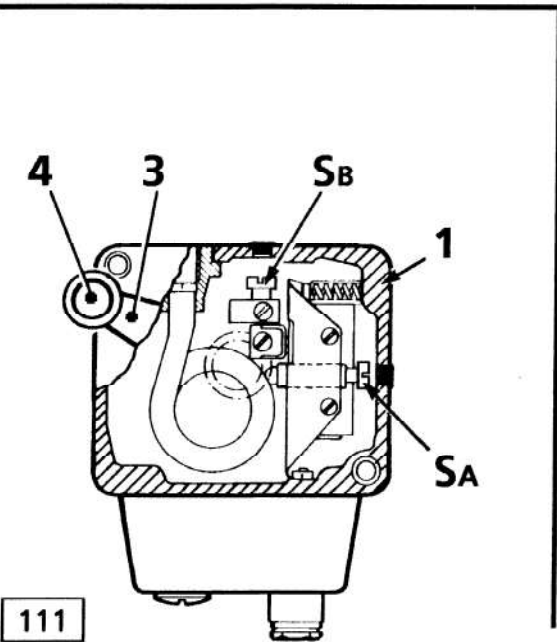

Hydraulic oil change intervals

1. Oil changes in preset intervals

Note: Oil changes in preset intervals are only permitted for mineral oils. When using environmentally friendly hydraulic fluids, oil sample analysis reports must be used to determine the time of the oil change, see §2.

a) In standard applications

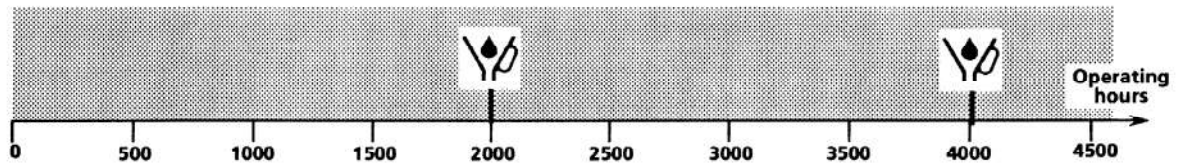

b) In dust intensive applications

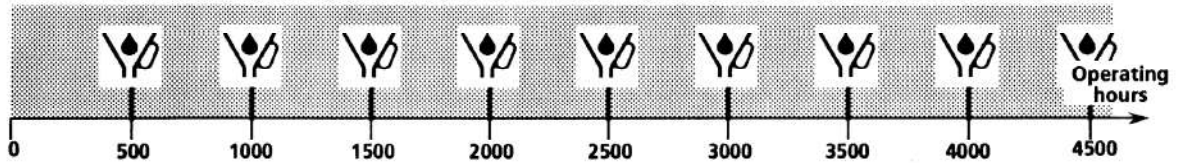

2. Optimized oil change intervals determined through oil sample analysis reports

Use this procedure to take oil samples in preset intervals. The intervals may be extended between two oil changes as long as the properties of the oil are still satisfactory. The time when the oil must be changed is determined by the lab report.

LIEBHERR recommends to submit the oil samples to "WEAR - CHECK" for oil analysis.

A kit for 6 complete analysis at WEAR - CHECK is available : Id. No. 7018368 (The kit contains the sample containers, documentation, shipping container and oil sample hose).

A hand pump is required to take the oil sample, and should be ordered separately (Id. No. 8145666).

a) In standard applications

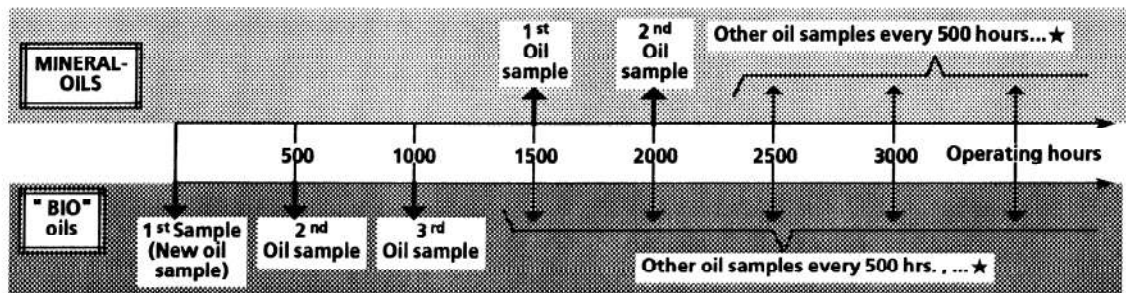

b) In dust intensive applications

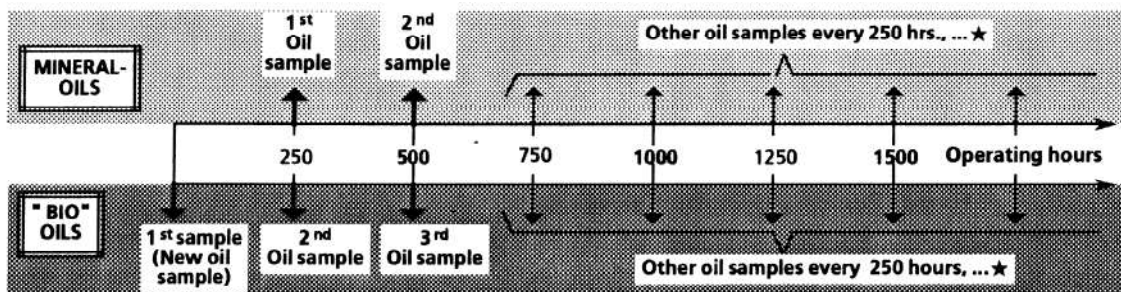

★ ...time for oil change determined by lab report

LUBRICATION OF ATTACHMENT BEARING POINTS

The bearings boom cylinder / upper frame, respectively boom / upper frame (2a) are greased via fittings 1 (fig.30) respec. via the fittings 2 on the lube plate in the upper's middle.

The remaining bearing points in the area boom and stick are combined into both lube fittings 4 (Fig. 30), via two metering devices.

With shovel attachment, the bearing points in the area of the shovel back are connected to the lube fitting 5 via an additional metering device.

These devices distribute a metered amount of grease to each connected bearing, when pressing grease into the fittings 4 and 5.

On the bucket, the different grease fittings are installed separately (fig. 31, pos. 3).

To lubricate the attachment, add grease daily or at every shift change on every grease fitting, until clean grease runs out of the corresponding bearing points.

See the lubricant chart for grease specification

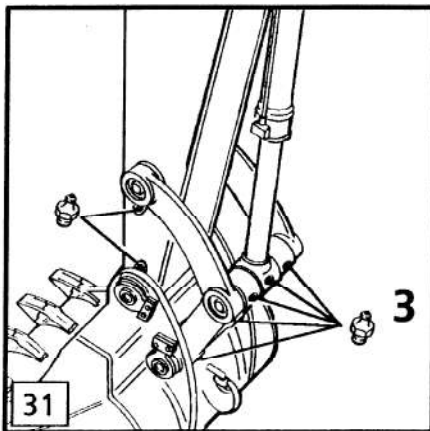
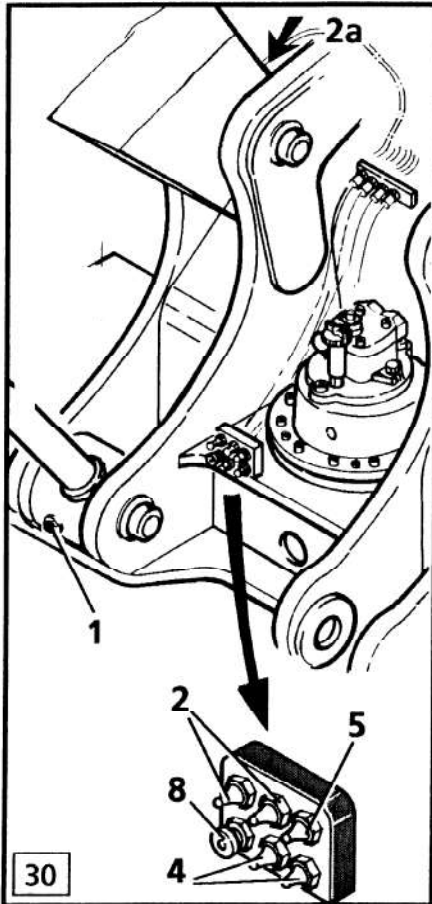

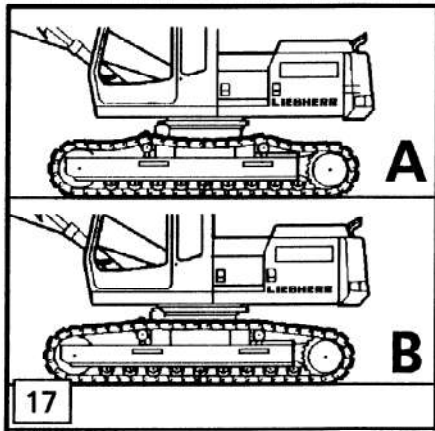

THE TRACK COMPONENTS

The tracks are maintenance free until the track pads or flanges need to be reconditioned or replaced. The lifetime seals in carrier rollers, track rollers and idlers increase the life expectancy of the tracks and protect from dirt and contamination.

However, even though the track is virtually maintenance free, the following points do need to be checked.

TIGHTENING THE TRACK TENSION

Fig. 17 A shows a track, that is not tightened properly, Fig. 17 B shows a track that is tightened properly.

The track tension needs to be checked regularly due to normal wear of the tracks, and tightened, if necessary.

The track chain tension is correct when the slack between both carrier rollers is about 1.2" (30 mm).

To check the chain slack (fig. 18) :

- measure X_1 , distance between running surface of carrier roller and top of sideframe
- measure X_2 , distance between chain link and top of sideframe
- calculate chain slack = $X_1 - X_2$.

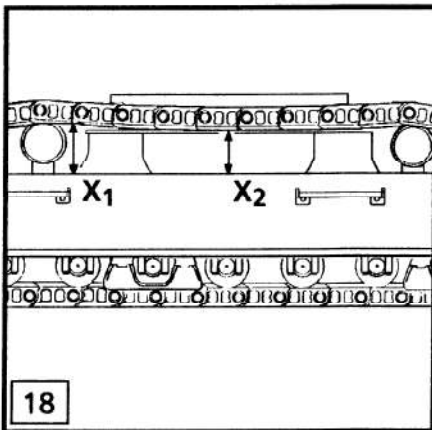

To tighten a track :

Remove the access cover (Fig. 19, pos. 4) on the side frame of the undercarriage.

Attach a special fitting 2 to grease gun 1 (Fig. 20). Connect the grease gun to cylinder 3.

Pump grease into cylinder 3 until the track chain is properly tensioned.

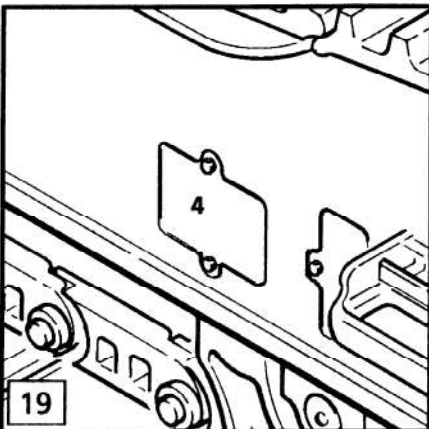

To release track tension, carefully release some grease from the grease cylinder by loosening and turning the grease fitting counterclockwise.

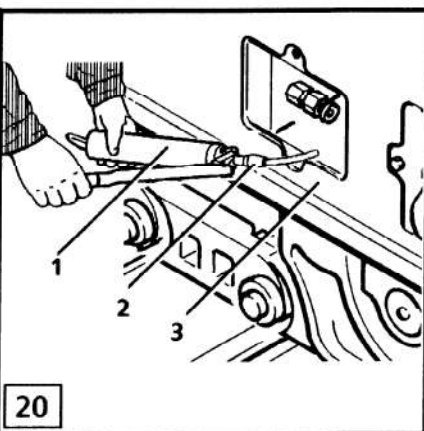

DANGER

When adjusting the chain tension, keep your head clear of the access hole. The grease cylinder is under high pressure and the chain will sag. Grease is under high pressure and might squirt out.

THE ELECTRICAL SYSTEM

To insure troublefree operation of your machine, the electrical system must be in good condition. The gauges, indicators and components of the electrical system should be checked daily for proper function.

Always replace burnt out fuses and bulbs. **DO NOT** repair fuses.

Check for bare and damaged wires which could cause damage to the electrical system or a fire. Check for loose, dirty or corroded connections.

IMPORTANT :

When performing repairs on the electrical system, or before using an arc welder on the machine, the negative battery terminal should be disconnected first and reconnected last.

Cover the electrical components (especially the alternator) when washing the excavator to protect it from water.

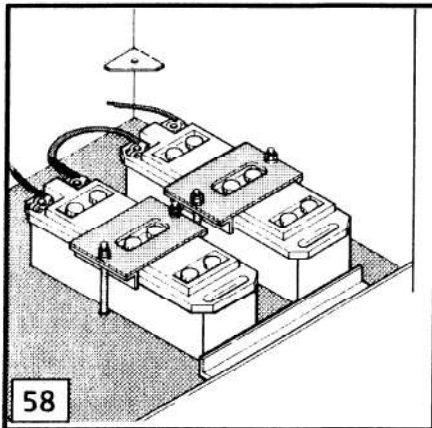

BATTERY MAINTENANCE

In order for the batteries to function properly, it is important to keep them clean at all times.

The battery poles and cable clamps in particular should be cleaned regularly and then coated with acid resistant grease (Fig. 58).

To check the electrolyte level, open battery compartment door, lift up rubber cover and remove caps.

The electrolyte level should be 1/2" (10 - 15 mm) above the plates.

If the electrolyte level is low, add distilled water.

Regularly check the specific gravity with a hydrometer. A fully charged battery should have a value of 1.28 kg/l (31.5°).

Batteries with a lower value should be recharged. Reinstall caps, check mounting security of batteries and close the battery compartment door.

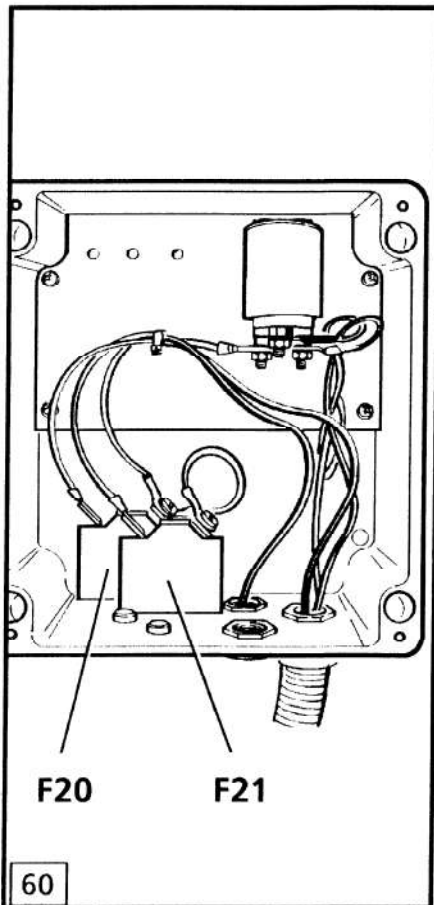

WARNING

Wear protective gloves and safety glasses when handling batteries!
Keep sparks and open flame away from battery.
Battery fumes are highly flammable and explosive.
Batteries contain acid which should not be touched. In case of contact, flush with water and get medical attention.

ARRANGEMENT OF THE CIRCUIT BREAKERS AND FUSES

The circuit breakers F 20 (main circuit), F 21 (starter circuit) and F 22 for the optional fuel pump are located in the electrical box mounted next to the batteries (fig. 60).

All other fuses are located on the printed circuit in the electrical box of the left joystick (Fig. 64). Remove the four screws and lift off the cover to get to the box.



WARNING

Use only original replacement fuses. If fuses blow frequently, the defect in the affected circuit must be checked and corrected. Never repair a blown fuse!

CLICK HERE TO **DOWNLOAD** THE COMPLETE MANUAL

- Thank you very much for reading the preview of the manual.
- You can download the complete manual from: www.heydownloads.com by clicking the link below



- Please note: If there is no response to CLICKING the link, please download this PDF first and then click on it.

CLICK HERE TO **DOWNLOAD** THE COMPLETE MANUAL