

Operation & Maintenance Manual

VEAM100200

WF550-3

TRASH LOADER

SERIAL NUMBERS W089-50001 AND UP

WARNING

Unsafe use of this machine may cause serious injury or death. Operators and maintenance personnel must read this manual before operating or maintaining this machine. This manual should be kept near the machine for reference and periodically reviewed by all personnel who will come into contact with it.

NOTICE

Komatsu has Operation & Maintenance Manuals written in some other languages. If a foreign language is necessary, contact your local distributor for availability.

KOMATSU

CLICK HERE TO **DOWNLOAD** THE COMPLETE MANUAL

- Thank you very much for reading the preview of the manual.
- You can download the complete manual from: www.heydownloads.com by clicking the link below



- Please note: If there is no response to CLICKING the link, please download this PDF first and then click on it.

CLICK HERE TO **DOWNLOAD** THE COMPLETE MANUAL

1.4.3. Position of service meter

On the lower right of maintenance monitor.

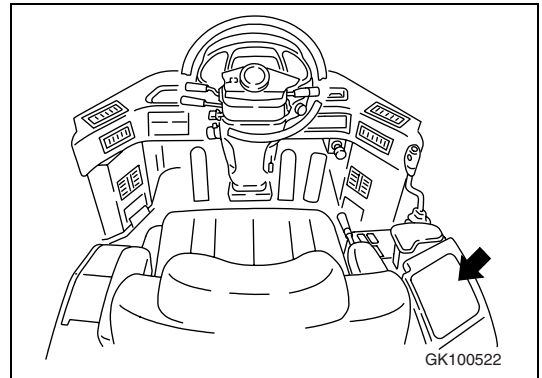

1.4.4. Table to enter serial no. and distributor

Machine serial No.:

Engine serial No.:

Name of Dealer:

Address:

Phone:

Service Personnel for your machine:

2.1.8. Fire prevention and fire fighting

- Fuel, oil, and antifreezing compound are highly inflammable and could cause a fire.
- Do not approach inflammable material with naked light.
- Prior to refuelling, switch off the engine and stop smoking.
- Refuelling and refilling of oil are to be performed in sufficiently ventilated places.
- Store oil and fuel in special places appropriate for this purpose. Ensure that unauthorised persons do not have access to these places.
- Tightly close all cover caps.
- Check the fuel system, the lubrication system, and the hydraulic system for leaks. Have leaks repaired. Remove any excess oil, fuel, or other inflammable substances.
- Carefully and completely remove wooden chippings, leaves, paper, and other highly inflammable materials that may have collected in the engine compartment, since they could cause a fire.
- A fully operational fire extinguisher must be available at hand.
- Do not operate the machine in the vicinity of naked light.

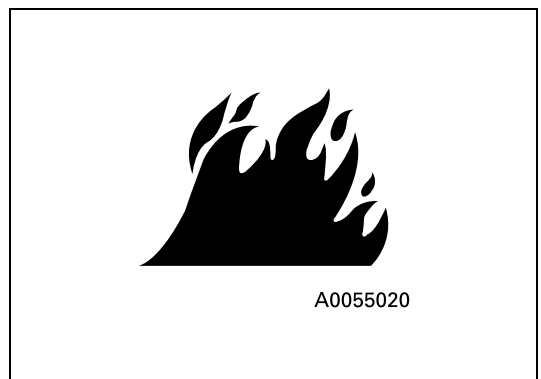
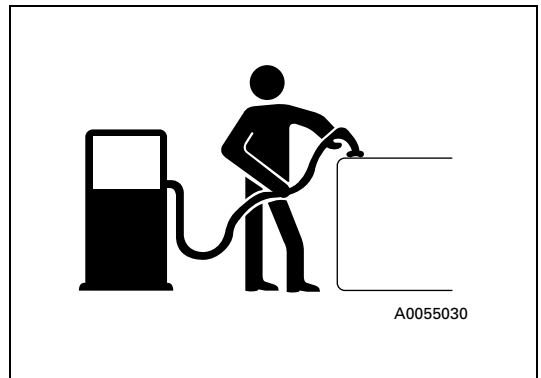

Working close to power lines

- A voltage overspill may occur, if you or the machine get too close to power lines. For this reason, always heed the required safety distance between the machine and the power lines.

Nominal Voltage		Safety Distance
	up to 1000 V	1 m
over 1 kV	up to 110 kV	3 m
over 110 kV	up to 220 kV	4 m
over 220 kV	up to 380 kV	5 m
with unknown nominal voltage		5 m

- The safety distances given here reflect the German safety standards. You can find the safety distances applying to your country in the relevant national regulations.
- Before you start work, obtain information about line voltages from your supply company.
- When estimating the distance, take into account all possible movements of the machine, the work unit, and the line. An uneven surface may result in the machine swaying, or wind may move the lines, etc.
- Should the work unit come into contact with a power line, proceed as follows:
 1. Do not leave the driver's cab. The driver's cab is a "Faraday cage" protecting you from electric shock.
 2. Warn other persons and tell them to stay far away from both the power line and your machine.
 3. Try to move the machine out of the range of influence of the power line by moving it away from the line, moving away the work unit, etc.
 4. Have the power in the line switched off.

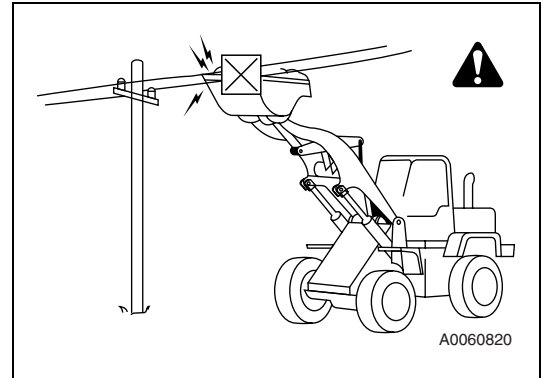

Use of lighting

Always use explosion-proof lighting when checking fuel, oil, coolant, or battery acid.

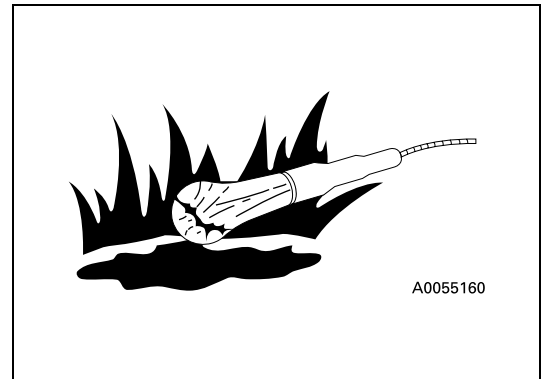

High-pressure hoses

Neither bend high-pressure hoses nor hit them with hard objects. Do not use piping or hoses with fissures, cracks, or bends, since they may burst during operation.

Immediately replace any loose or damaged fuel or oil hoses. Leaking fuel or oil involves danger of fire and slipping.

Replace all hoses every six years at the latest.

Handling high-pressure oil

- Always take into account that the hydraulic lines are subjected to high pressure.
- Do not top up oil, drain oil, or perform maintenance or inspection measures unless the work unit is completely lowered and the system is depressurised.
- If oil comes out under high pressure, this involves danger of an oil jet penetrating the skin or getting into the eyes. For this reason, always wear safety goggles and thick safety gloves, and use a piece of cardboard or wood when checking for oil leaks.
- If you have been hit by an oil jet, immediately go and see a doctor and explain what has happened.

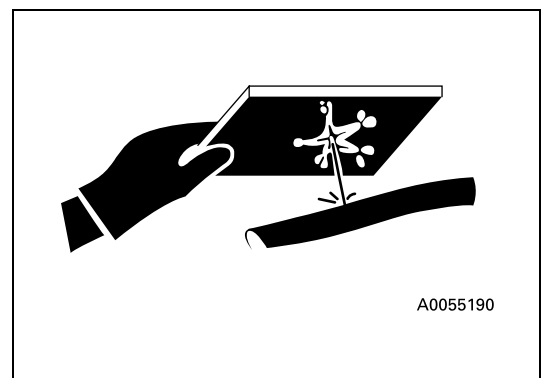

3.2. Description of the individual elements

3.2.1. Control monitor

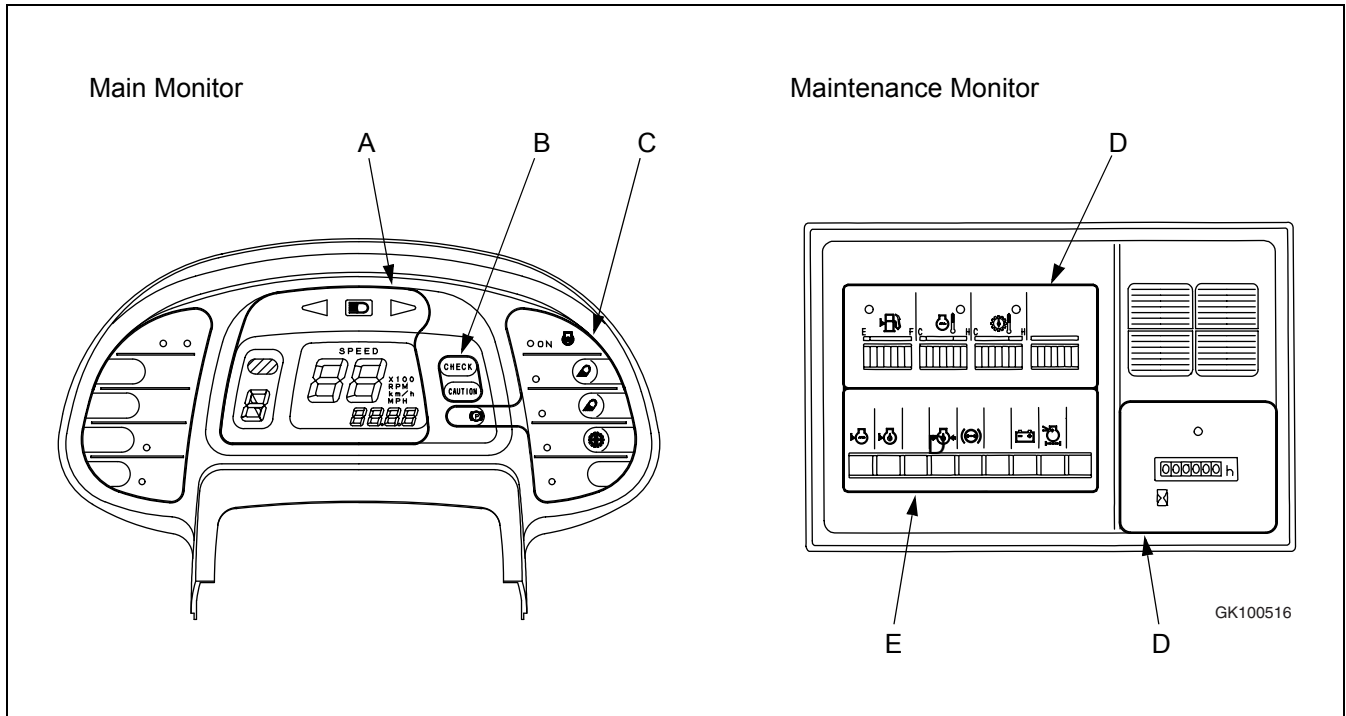

The monitoring system consists of the main monitor and the maintenance monitor. Depending on the function type, the control system can be divided in:

- A, C and D** Control and measurement indicators
- B, E** Alarm indicators

In the following sections you will find an explanation of all devices required for efficient machine operation. To carry out all operations correctly and safely, it is important to fully understand the operating principles of the equipment and the meaning of the indicators/displays.

Control and measurement indicators (A, C and D)

These parts comprise the meters (speedometer, fuel gauge, engine water temperature gauge, torque converter oil temperature gauge, service meter, transmission shift indicator) and the pilot lamps (turn signal indicator, preheating, front working lamp, rear working lamp, transmission cut-off, parking brake).

Alarm indicators (B, E)

These parts comprise the central check lamp (CHECK), the central warning lamp (CAUTION), and warning pilot lamps (engine water level, engine oil level, brake oil pressure, engine oil pressure, battery charge, and air cleaner clogging).

13. Gear shift indicator

This indicator indicates the present speed range of the transmission. When the directional lever is in the N position, N is displayed on the indicator.

When the directional lever is in the F or R position, the gear position of the gear shift lever is displayed as a numeral.

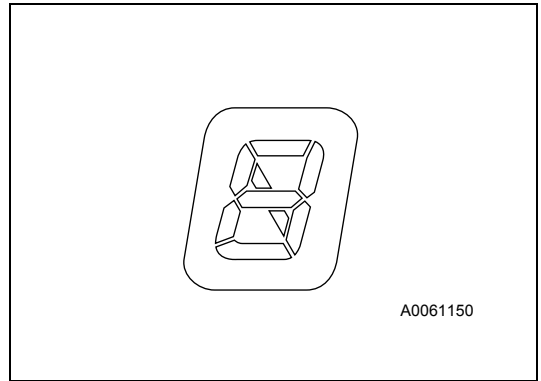

3.2.3. Control levers and pedals

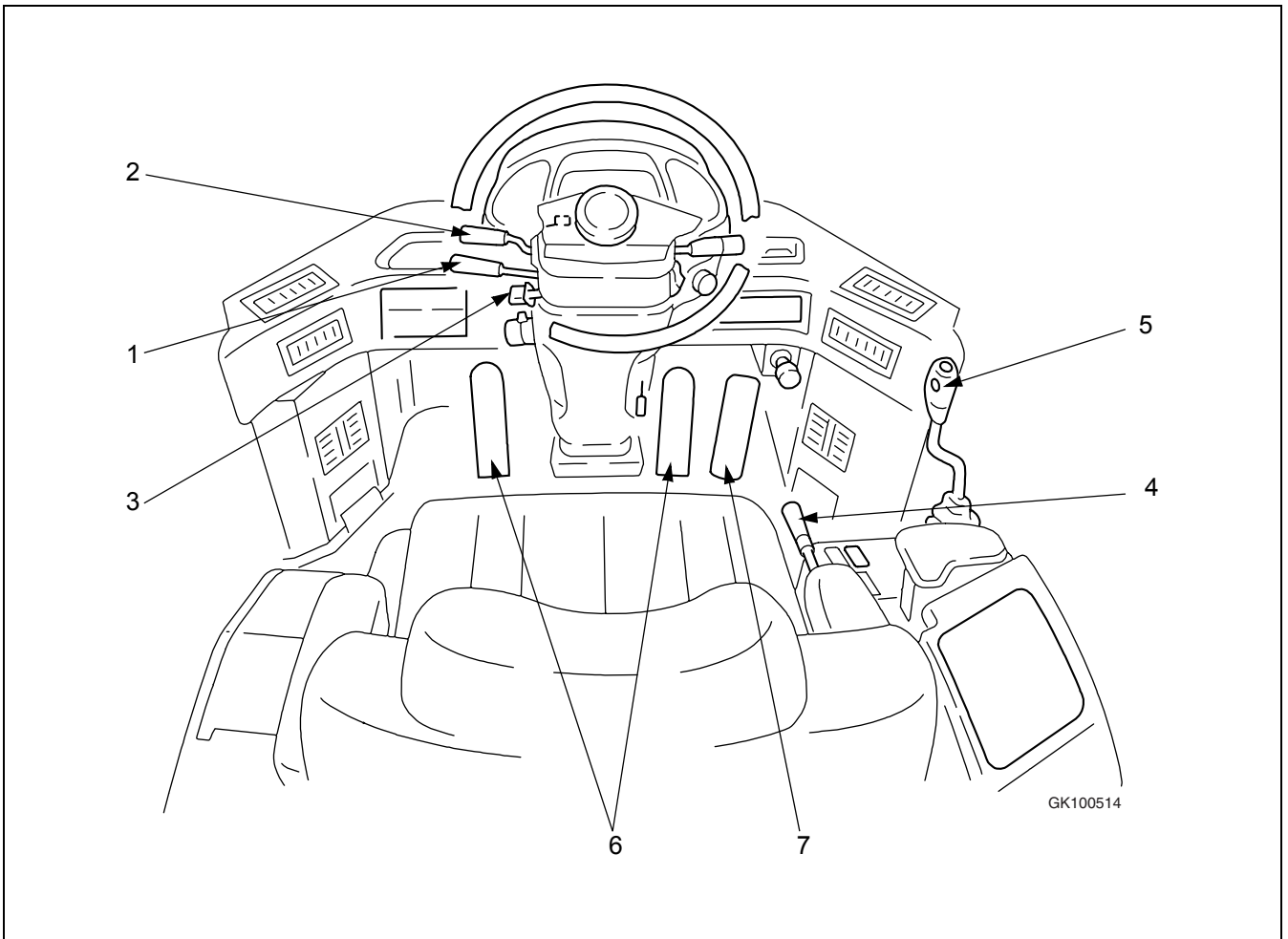

1. Gear lever

This lever controls the travel speed of the machine. The machine is fitted with an automatic transmission with 4 FORWARD and 4 REVERSE GEARS.

Push the gear lever into the position for the required speed range.

- 1st and 2nd gears are used for working.
- 3rd and 4th gears are used for travel.

If the gear lever stop (A) is applied (see item "3. Gear lever stop" on page 3-27), it is not possible to shift into 3rd or 4th gear. Deactivate the gear lever stop before changing gear.

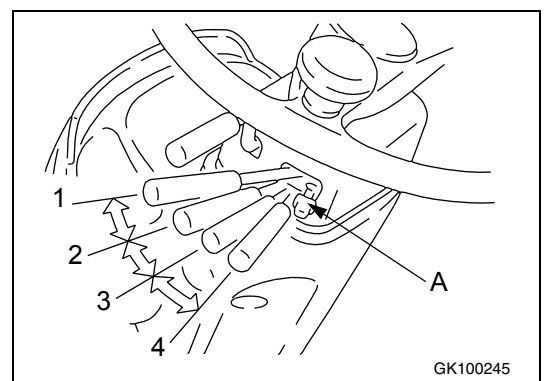

- Position 1 1st gear
- Position 2 2nd gear
- Position 3 3rd gear
- Position 4 4th gear

Fuse box 2

No.	Fuse Capacity	Name of circuit
1	20 A	Front working lamp
2	20 A	Rear working lamp
3	30 A	Air conditioner 1
4	20 A	Air conditioner 2
5	20 A	Wiper, washer
6	10 A	Auto shift (option)
7	10 A	Cigarette lighter, radio
8	10 A	Rotating lamp (option)
9	10 A	Spare
10	10 A	Auto greasing (option)
11	10 A	Spare
12	10 A	Spare
13	10 A	Spare
14	10 A	Spare
15	10 A	Spare

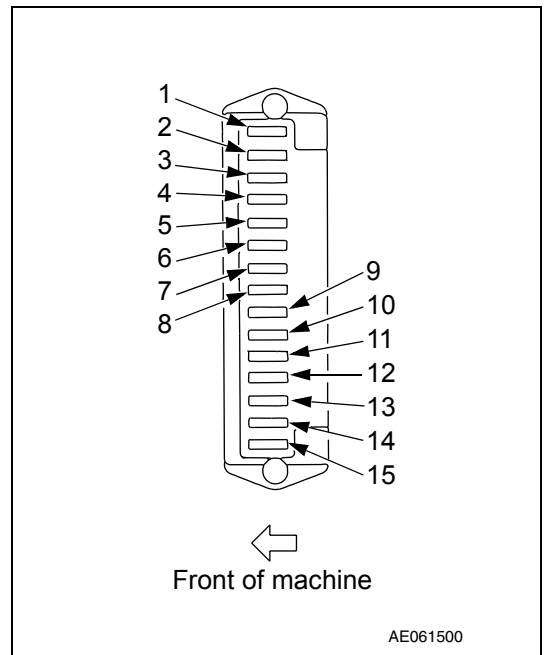

AE061500

3.3. Operation

3.3.1. Pre-start checks

Walk-around check

WARNING

- Always attach the warning tag to control lever (1) in the operator's cab to alert others that you are working on the machine.
- Leaking oil or fuel, or accumulation of flammable material around high temperature parts, such as the engine muffler or turbocharger, may cause fire. Check these points carefully; if any abnormality is found, repair it or contact your Komatsu dealer.

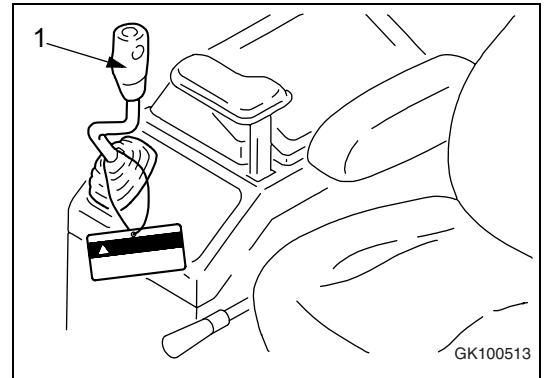

Before starting the engine, look around the machine and under the machine to check for loose nuts or bolts, or leaking oil, fuel, or coolant, and check the condition of the work equipment and hydraulic system. Check also for loose wiring, play, and collection of dust at places which reach high temperatures.

Always carry out the items in this section before starting the engine each day.

1. Check for damage, wear, play in work equipment, cylinders, linkage, hoses

Check that there are no cracks, excessive wear and tear, or play in the work equipment, cylinders, linkage, or hoses. If any abnormality is found, repair it.

2. Remove dirt and dust from around engine, battery, radiator

Check if there is any dirt or dust accumulated around the engine or radiator. Check also if there is any flammable material (dead leaves, twigs, grass, etc.) accumulated around the battery or high temperature engine parts, such as the engine muffler or turbocharger. Remove all such dirt or flammable material.

3. Check for leakage of water or oil around engine

Check that there is no oil leakage from the engine or water leakage from the cooling system. If any abnormality is found, repair it.

Operations and checks before starting the engine

WARNING

- If either the control levers or the multi-function control lever are accidentally touched, the work equipment may move suddenly. When leaving the operator's compartment, always set the safety lever to the LOCK position.
- Before starting the engine, use a damp cloth to wipe off the dust accumulated on top of battery, starting motor and alternator.

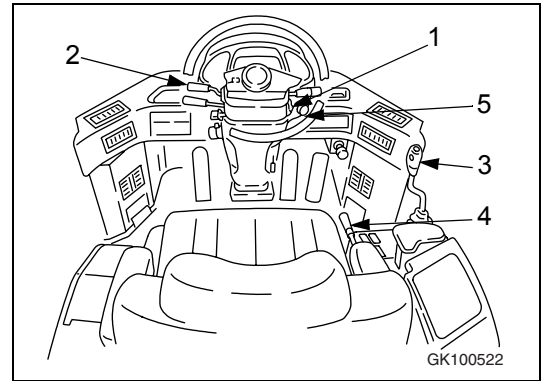

1. Check that parking brake switch (1) is at the ON position.

- Position 1 ON
- Position 2 OFF

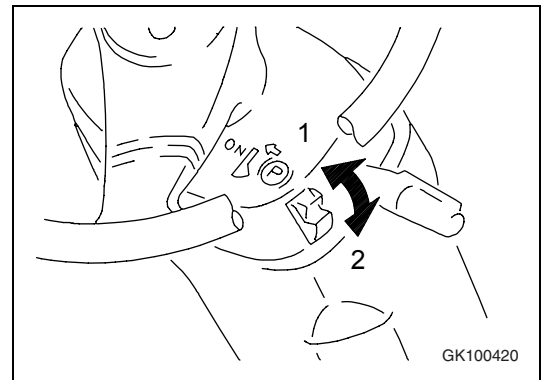

2. Check that either the directional lever (2) is set to the 'N' position.
If directional lever (2) is not set to 'N' the engine will not start.

- Position N Neutral

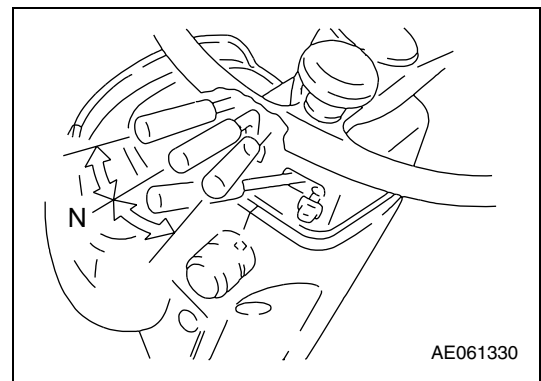

3. Lower the bucket to the ground, then check that work equipment control lever (3) is locked by safety lock (4).

- Position 1 Work hydraulic system locked
- Position 2 Work hydraulic system unlocked

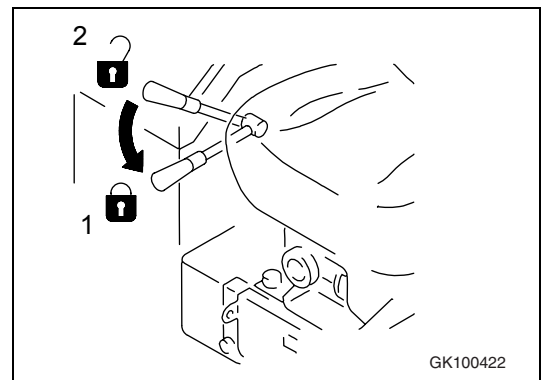

4. Start the engine and press the green switch (4) on the housing of the steering joystick. Joystick steering (5) is activated if the indicator lamp in the switch lights up.

NOTE

Joystick steering (5) is switched off if the indicator lamp in the red switch lights up.

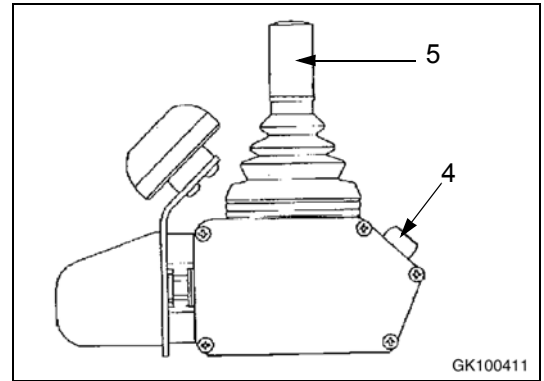

5. Depress right brake pedal (7) and turn parking brake switch (8) to the OFF (RELEASE) position to release the parking brake. Keep right brake pedal (7) depressed.

NOTE

If the parking brake is still actuated when parking brake switch (8) is at the OFF (RELEASE) position, turn the parking brake switch ON, then turn it OFF again.

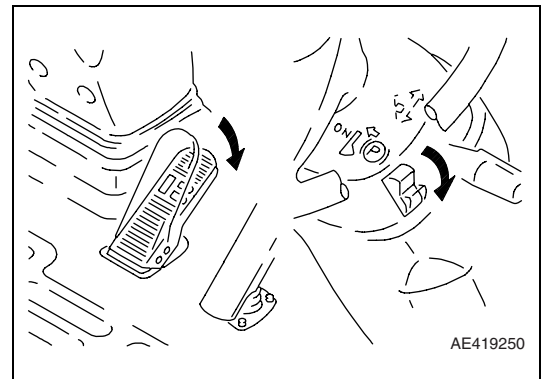

6. Shift the gear lever (9) to the required gear.

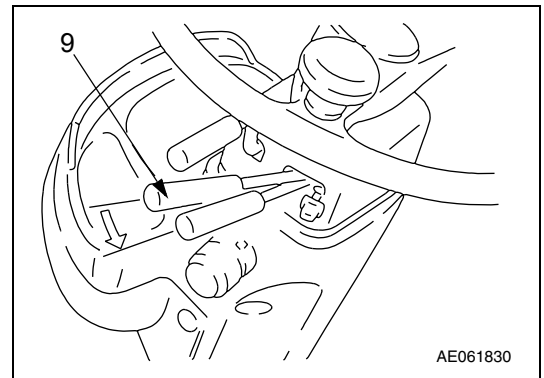

7. Select travel direction using the joystick.

- Position V Forward drive
- Position N Neutral
- Position R Reverse drive

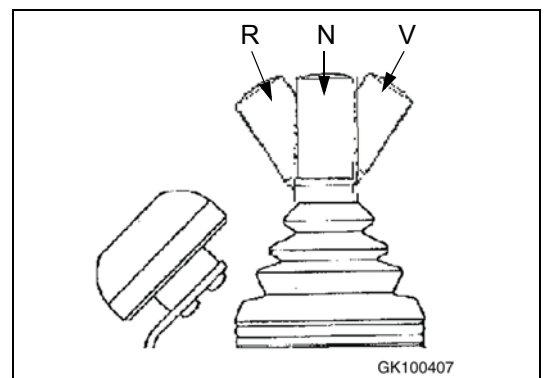

CLICK HERE TO **DOWNLOAD** THE COMPLETE MANUAL

- Thank you very much for reading the preview of the manual.
- You can download the complete manual from: www.heydownloads.com by clicking the link below



- Please note: If there is no response to CLICKING the link, please download this PDF first and then click on it.

CLICK HERE TO **DOWNLOAD** THE COMPLETE MANUAL

Levelling

NOTE

- **Always operate the machine in reverse when carrying out levelling operations.**
 - **If it is necessary to perform levelling works when travelling forward, do not set the bucket dumping angle to more than 20°.**
 - **If the piled soil is viscous, it will stick to the steel wheels and cause them to slip. For this reason, it is more effective to avoid working after rain and operate when there is little moisture and the soil is dry. Insuring good drainage will improve the efficiency by allowing the soil to dry more quickly after rain.**
1. Scoop soil into the bucket. Move the machine backward while spreading soil from the bucket little by little.
 2. Go over the spread soil with the bucket teeth touching the ground and level the ground by back-dragging.
 3. Scoop some more soil into the bucket, set the lift arm to float position, level the bucket at ground level, and smooth the ground by moving backward.

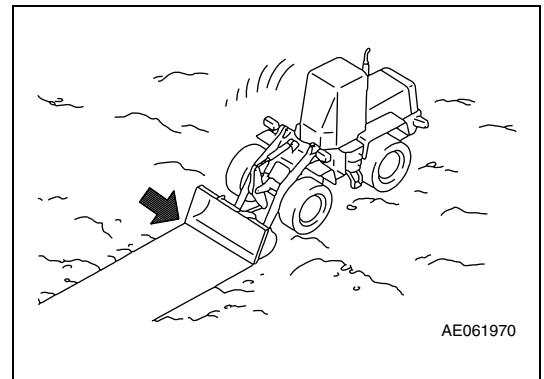

Pushing

NOTE

Never set the bucket to the DUMP position when carrying out pushing operations.

When carrying out pushing operations, set the bottom of the bucket parallel to the ground surface.

3.4. Transport

3.4.1. Loading and securing

Observe all safety instructions carefully in order to prevent accidents with severe injury.

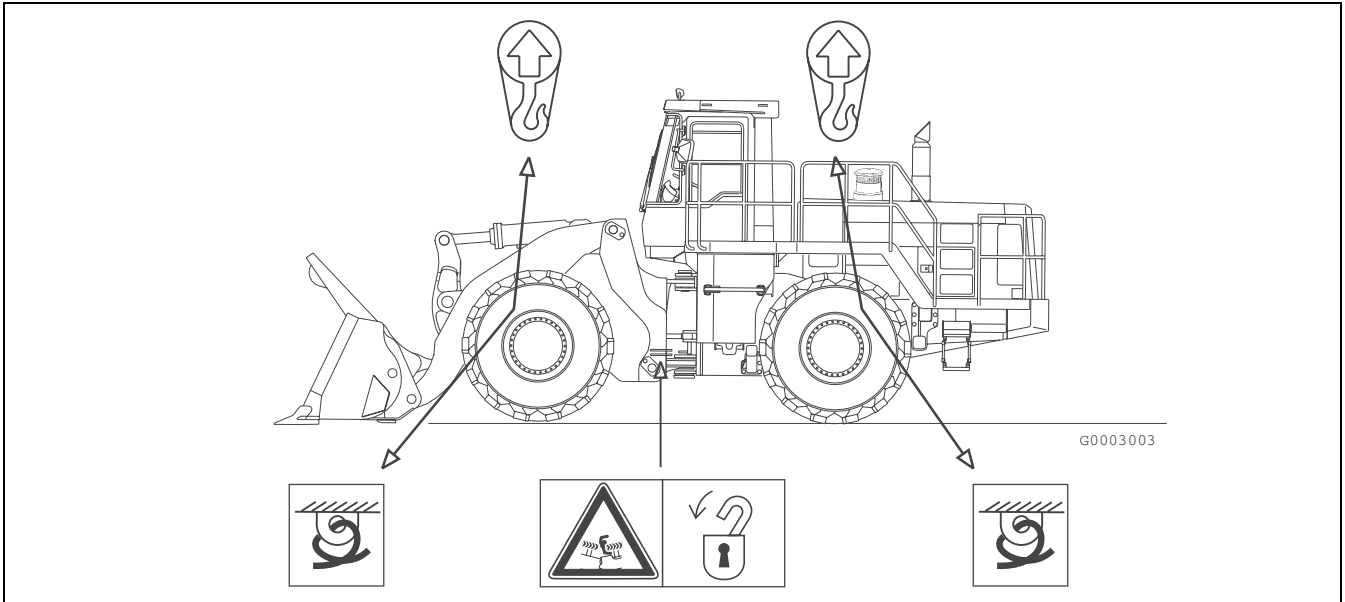

⚠ DANGER

- Always secure articulated joint if maintenance or repair work is to be carried out or if the machine is going to be lifted or transported.
- An articulated joint may jack-knife unexpectedly if not secured. Danger of injury if joint jack-knifes.

Position machine as if driving in forward direction and secure articulated joint against jack-knifing, using the articulated-joint lock. Always secure securing bar in either position using bolt and spring pin.

NOTE

- Remove the rear wheel covers before transporting the machine by crane.
- Due to safety reasons and to avoid consequential damages, it is prohibited to attach other points (such as axles, cardan shafts, articulated joint, bucket teeth) than those specified for lifting and securing. It is also prohibited to attach ropes etc. to the driver's cabin.

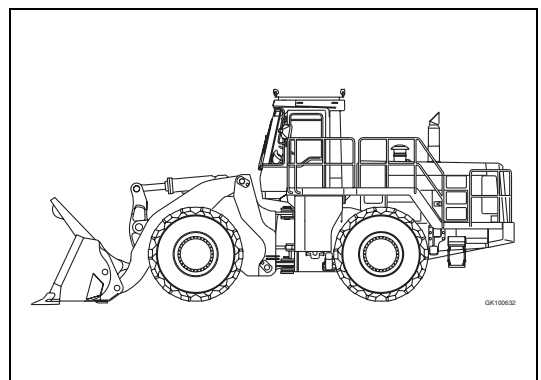
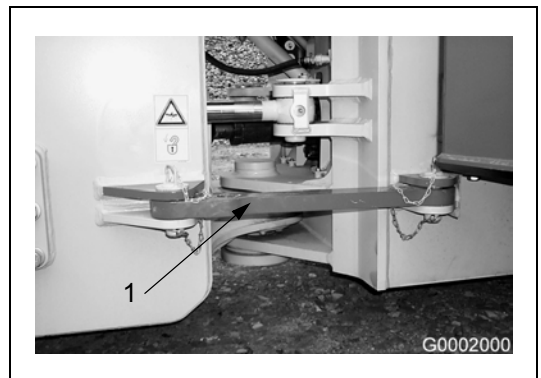

4.1.1. Central lubrication system

4.1.2. No grease emerging at the lubrication points

- Check level of grease in grease reservoir, top up if necessary.
- Start a manual auxiliary lubrication process.
- Switch ignition on and press button (2).
- The stirrer in the grease reservoir rotates when the pump is switched on.
- Check the distribution pipelines for leaks. Tighten any loose connections.

Please contact your local KOMATSU dealer if grease is still not emerging from the lubrication points.

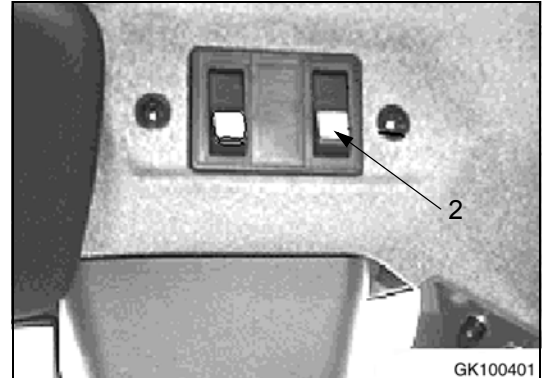

4.1.3. The pump does not switch on

- Check the fuses.
- Check whether the electrical plug on the underside of the pump housing is connected tight with the power socket.
- If necessary, turn bayonet connector clockwise.
- Start a manual auxiliary lubrication process. Switch ignition on and press button (2).

Please contact your local KOMATSU dealer if the pump does not switch on.

4.3.3. Starting the engine with a booster cable

For starting the engine with a booster cable, proceed as follows:

Precautions for connecting and disconnecting the booster cable

The batteries are on both sides at the rear of the machine. The battery used for the ground is on the right side of the machine.

⚠ WARNING

- When connecting the cables, never contact the positive (+) and negative (-) terminals.
- When starting the engine with a booster cable, always wear safety glasses and rubber gloves.
- Be careful not to let the normal machine and defective machine contact each other. This prevents sparks from being generated near the battery which could ignite the hydrogen gas leaking from the battery. If hydrogen gas explodes, it may cause serious injury.
- Make sure that there is no mistake in the booster cable connections. The final connection is made to the engine block of the defective machine, but sparks will be generated when this is done, so connect it to a place as far as possible from the battery.
- Be careful when removing the cables from the machine that has been started. Do not allow the cable ends to contact each other or the machine to avoid hydrogen explosion.

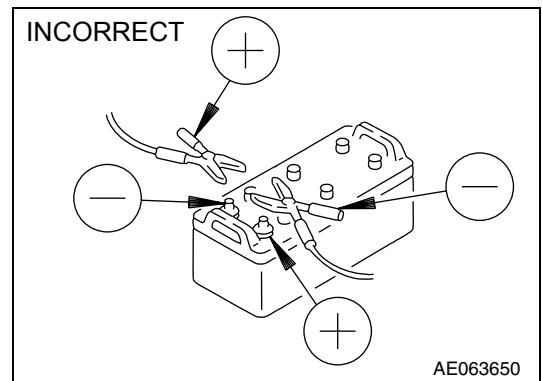

NOTE

- The size of the booster cable and clip should be suitable for the battery size.
- The battery of the normal machine must have the same capacity as that of the engine to be started.
- Check the cables and clips for damage or corrosion.
- Make sure that the cables and clips are firmly connected.
- Check that the safety lock levers and the parking brakes of both machines are at the LOCK position.
- Check that all the levers are at the neutral position.

5. Maintenance

NOTE

- **When fuel sulphur content is less than 0.5%, change oil in the oil pan every periodic maintenance hours described in this manual. Change oil according to the following table if fuel sulphur content is above 0.5%.**

Fuel sulphur content	Change interval of oil in engine oil pan
0.5 to 1.0 %	1/2 of regular interval
Above 1.0 %	1/4 of regular interval

- **When starting the engine in an atmospheric temperature of lower than 0½C, be sure to use engine oil of SAE10W, SAE10W-30 and SAE15W-40, even though an atmospheric temperature goes up to 10½C more or less in the day time.**
- **Use API classification CD as engine oil and if API classification CC, reduce the engine oil change interval to half.**
- **There is no problem if single grade oil is mixed with multigrade oil (SAE10W-30, 15W-40), but be sure to add single grade oil that matches the temperature in the table.**
- **We recommend Komatsu genuine oil which has been specifically formulated and approved for use in engine and hydraulic work equipment applications.**

Specified capacity: Total amount of oil including oil for components and oil in piping.

Refill capacity: Amount of oil needed to refill system during normal inspection and maintenance.

ASTM: American Society of Testing and Material

SAE: Society of Automotive Engineers

API: American Petroleum Institute

- Remove the seal from the outer element after cleaning it.

The outer element must be replaced after 6 times of cleaning or after one year of use. Always replace outer and inner element together.

If the dust indicator displays red immediately after the outer element has been cleaned, replace both the inner and outer element, even if the outer element has not been cleaned 6 times.

Check the inner element mounting nuts for looseness and, if necessary, retighten. Check the inner element mounting nuts for looseness and, if necessary, retighten.

Replace seal washer (5) or wing nut (4) with new parts if they are broken.

NOTE

If small holes or thinner parts are found on the element when checking it with an electric bulb after cleaning and drying, replace the element.

When cleaning the element, do not hit it or beat it against other objects.

Do not use elements with damaged gasket or seal or groove.

- Reinstall the cleaned element.

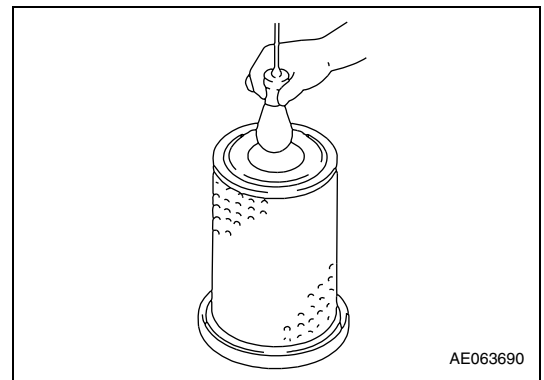
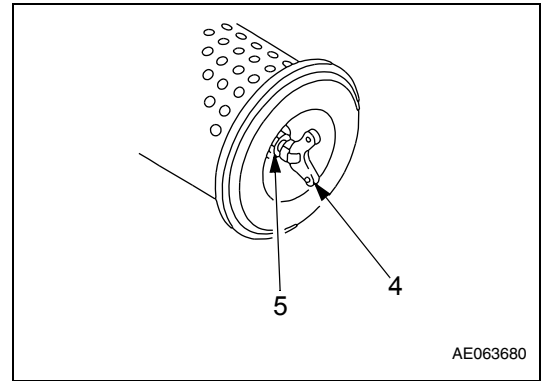

Replacing the internal element

- First remove the outer element of the air cleaner and then the internal protective element.
- To prevent dust from intruding, use a clean cloth or tape to cover the air connector (outlet side).
- Clean the interior of the air cleaner body, then remove the cover installed in step 2.
- Fit a new internal element to the connector and tighten it with nuts. Do not clean and reinstall an inner element.

NOTE

Do not clean the inner element and use it again. When replacing the outer element, replace the inner element at the same time.

- Install the outer element.

NOTE

When installing the inner element and outer element, turn the element lightly so that the seal rubber at the tip of the element fits tightly inside the body, then tighten the nut.

Replacing the bucket teeth

Replace the teeth before they wear down as far as the adaptor.

1. Extract pin (2) fitted to the bucket and then remove tooth (1). When extracting pin (2), strike the part (either the left or right part) with a sharp object. This will enable the pin to be extracted from the opposite side.
2. Insert the new tooth (1) into the adaptor (3), and insert pin (2) partway as shown in the diagram. Then drive it home by means of a hammer.

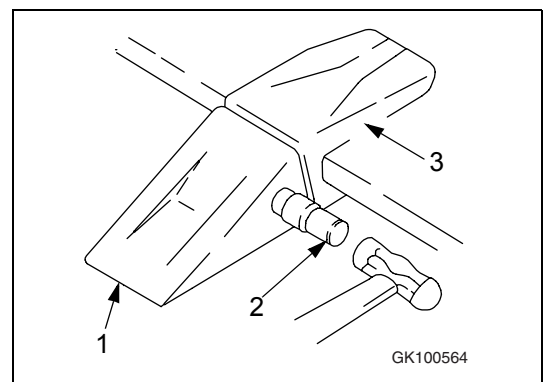
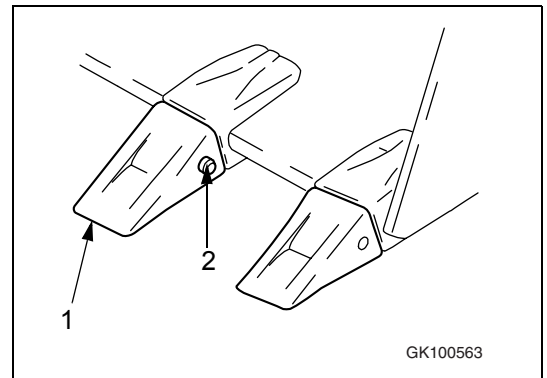

5.9.5. Every 100 hours service

This coincides with the 50 hours service.

Checking the oil level in the hydraulic tank, adding oil

WARNING

- When the oil filler cap is removed, oil may spurt out, so stop the engine and wait for the oil temperature to cool down; then turn the cap slowly to release the internal pressure before removing the cap.
- If oil has been filled up above the H mark, stop the engine and wait for the hydraulic oil to cool down, then drain the excess oil from the drain plug.

1. Lower the bucket horizontally to the ground and stop the engine. Wait for 5 minutes, then check sight gauge (G). The oil level should be between the H and L marks.

NOTE

Do not add oil if the level is above the H line. This will damage the hydraulic equipment and cause the oil to spurt out.

2. If the oil is below the L level, open the inspection cover above the step and add oil through the oil filler port (F).

For details of the oil to be used, see section "5.4. Use of fuel, coolant and lubricants according to ambient temperature" on page 5-10.

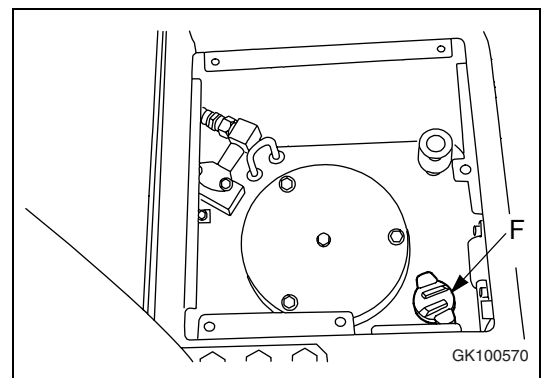
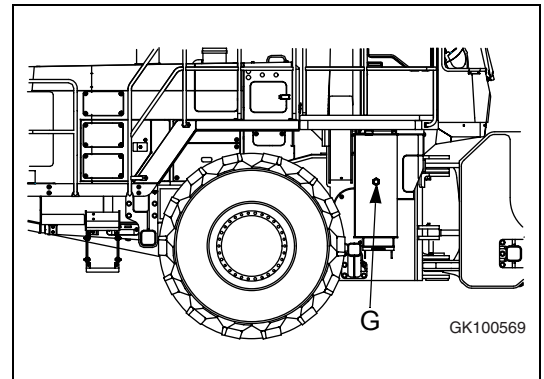

there is any damage or dirt or dust caught in the surface, replace the packing with a new part, then repeat steps 4 to 9 to install again.

20. Check that the hydraulic oil is at the correct level. For details, see section "5.9.5. Every 100 hours service" on page 5-41.
21. Check that there is no leakage of oil from the filter cover mount.

Label at front of protective ventilation unit

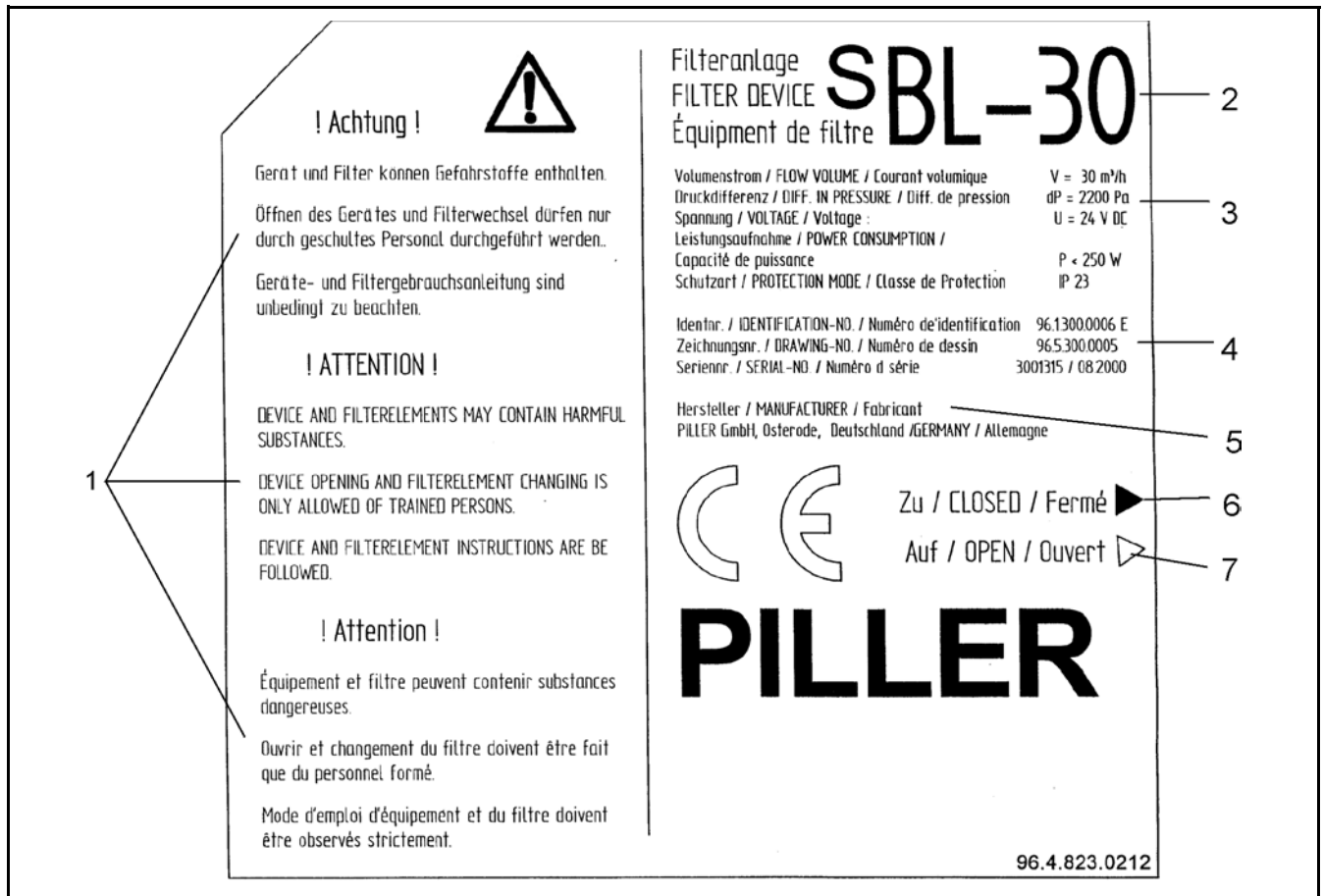

- | | | | | | |
|--|---|---|---|--|------------------------|
| <p>1 ! Attention !
 Device and filter elements may contain harmful substances. Device opening and filter element changing are only allowed of trained persons. Device and filter element instructions are be followed</p> | <p>2 Filter device SBL-30</p> <p>Flow volume V = 30 m³/h
 Difference in pressure dP = 2200 Pa</p> | <p>3 Voltage U = 24 V DC
 Power consumption P < 250 W
 Protection mode IP 23</p> | <p>4 Identification-no. = see label
 Drawing-no. = see label
 Serial-no. = see label</p> | <p>5 Manufacturer: Piller GmbH, Osterode, Germany</p> | <p>6 Closed</p> |
| | | | | | <p>7 Open</p> |

Selection and use

Escape filter units are designed exclusively for self-protection. The selection and use of filter units is up to the operator. Particular attention must therefore be paid to the following:

The AUER MSR 2 protects against organic gas and vapours with a boiling point of + 65 °C, inorganic, acidic and alkaline gases and vapours and particle-shaped pollutants.

 **WARNING**

- **Limited protection exists against low-boilers, i. e. gases and vapours with a boiling point of less than 65 °C and with a high pollutant concentration.**
 - **No protection exists against carbon monoxide and lack of oxygen. Escape filter devices do not supply any oxygen.**
-

Service life of this escape filter device: **15 minutes**.

Application

Escape filter devices are only designed to be used once. In the event of an emergency escape situation, keep calm and do not panic. Breathing may be more difficult because of the breath resistance of the escape filter device.

 **WARNING**

People with beards, long sideburns or anomalies in the region of the mask sealing line have to expect that a tight seat of the mask cannot be achieved. This can also occur in the cases of extreme facial shapes and sizes.

Maintenance and storage

Maintenance should only be carried out by the manufacturer's authorized agents. The escape filter devices are maintenance-free during the storage period. The end of storage life is shown on the equipment (egg-timer symbol).

Do not open the protection bag before using. Replace any damaged or opened devices with fault-free escape filter devices.

CLICK HERE TO **DOWNLOAD** THE COMPLETE MANUAL

- Thank you very much for reading the preview of the manual.
- You can download the complete manual from: www.heydownloads.com by clicking the link below



- Please note: If there is no response to CLICKING the link, please download this PDF first and then click on it.

CLICK HERE TO **DOWNLOAD** THE COMPLETE MANUAL