

Operation & Maintenance Manual

WHEEL LOADER

WD600-6

SERIAL NUMBERS 55012 and up

ecot3

⚠ WARNING

Unsafe use of this machine may cause serious injury or death. Operators and maintenance personnel must read this manual before operating or maintaining this machine. This manual should be kept near the machine for reference and periodically reviewed by all personnel who will come into contact with it.

NOTICE

Komatsu has Operation & Maintenance Manuals written in some other languages. If a foreign language manual is necessary, contact your local distributor for availability.

KOMATSU

CLICK HERE TO **DOWNLOAD** THE COMPLETE MANUAL

- Thank you very much for reading the preview of the manual.
- You can download the complete manual from: www.heydownloads.com by clicking the link below



- Please note: If there is no response to CLICKING the link, please download this PDF first and then click on it.

CLICK HERE TO **DOWNLOAD** THE COMPLETE MANUAL

OTHER TROUBLE	3-183
MAINTENANCE	4- 1
GUIDES TO MAINTENANCE	4- 2
OUTLINES OF SERVICE	4- 4
HANDLING OIL, FUEL, COOLANT, AND PERFORMING OIL CLINIC	4- 4
OUTLINE OF ELECTRIC SYSTEM	4- 8
WEAR PARTS	4- 9
WEAR PARTS LIST	4- 9
RECOMMENDED FUEL, COOLANT, AND LUBRICANT	4- 11
USE OF FUEL, COOLANT AND LUBRICANTS ACCORDING TO AMBIENT TEMPERATURE	4- 12
RECOMMENDED BRANDS, RECOMMENDED QUALITY FOR PRODUCTS OTHER THAN KOMATSU GENUINE OIL	4- 13
STANDARD TIGHTENING TORQUES FOR BOLTS AND NUTS	4- 14
TORQUE LIST	4- 14
PERIODIC REPLACEMENT OF SAFETY CRITICAL PARTS	4- 16
SAFETY CRITICAL PARTS	4- 17
MAINTENANCE SCHEDULE CHART	4- 19
MAINTENANCE SCHEDULE CHART	4- 19
SERVICE PROCEDURE	4- 21
INITIAL 10 HOURS SERVICE (SERVICE FOR FIRST 50 HOURS ON NEW MACHINE)	4- 21
INITIAL 250 HOURS SERVICE	4- 21
WHEN REQUIRED	4- 22
CHECK BEFORE STARTING	4- 50
EVERY 50 HOURS SERVICE	4- 51
EVERY 100 HOURS SERVICE	4- 52
EVERY 250 HOURS SERVICE	4- 58
EVERY 500 HOURS SERVICE	4- 61
EVERY 1000 HOURS SERVICE	4- 69
EVERY 2000 HOURS SERVICE	4- 74
EVERY 4000 HOURS SERVICE	4- 81
EVERY 8000 HOURS SERVICE	4- 86
SPECIFICATIONS	5- 1
SPECIFICATIONS	5- 2
ATTACHMENTS, OPTIONS	6- 1
HANDLING STEERING WHEEL SPECIFICATION MACHINE	6- 2
EXPLANATION OF COMPONENTS	6- 2
FUNCTIONS OF STEERING WHEEL SPECIFICATION MACHINE	6- 12
STARTING IN COLD AREAS	6- 22
ELECTRIC HEATER	6- 22
HANDLING AUTO-GREASING SYSTEM	6- 27
METHOD OF OPERATING AUTO-GREASING SYSTEM	6- 27
PRECAUTIONS WHEN HANDLING AUTO-GREASING SYSTEM	6- 34
TROUBLESHOOTING	6- 34
HANDLING REAR FENDER	6- 35
HANDLING	6- 35
HANDLING FUEL QUICK CHARGE	6- 36
PROCEDURE FOR OPERATING FUEL CHARGE	6- 36
INSPECTION AND MAINTENANCE	6- 37
HANDLING MACHINES EQUIPPED WITH KOMTRAX Plus	6- 38
KOMTRAX Plus INSTALLED, COMMUNICATIONS TERMINAL NOT INSTALLED	6- 38

(4) Caution for going close to electric cables (09801-13001)

VOLTAGE		SAFE DISTANCE
LOW VOLTAGE	100V 200V	2 m
	6,600V	2 m
SPECIAL HIGH VOLTAGE	22,000V	3 m
	66,000V	4 m
	154,000V	5 m
	187,000V	6 m
	275,000V	7 m
	500,000V	11 m

09801-13001

(5) Do not enter

Crush Hazard. Can cause severe injury or death. When machine is being operated, never place yourself in articulated area of machine.

(6) Caution for frame lock bar

If safety bar is unlocked, machine can jackknife unexpectedly when it is being transported or hoisted.

Jackknifing can cause serious injury or death to bystanders.

- Always lock safety bar when machine is being transported or hoisted.
- If necessary, lock safety bar during servicing or maintenance.

(7) Precautions when releasing parking brake (09809-03000)

If the switch is set to RELEASE, a serious accident could result, as this operation releases the parking brake and the machine may move off suddenly. Never set the switch to RELEASE except when towing a disabled machine. Before towing such machine, read its manual carefully and be sure to follow the instructions given therein.

09809-03000

NO PEOPLE ON ATTACHMENTS

Never let anyone ride on the work equipment or other attachments. There is a hazard of falling and suffering serious personal injury or death.

PRECAUTIONS WHEN STANDING UP FROM OPERATOR'S SEAT

Before standing up from the operator's seat, such as when adjusting the position of the seat, always lower the work equipment completely to the ground, set work equipment lock lever (1) and steering lock lever (2) to the lock position (L), turn parking brake switch (3) ON, and stop the engine.

If the control levers are touched by mistake, the machine may suddenly move and cause serious personal injury or death.

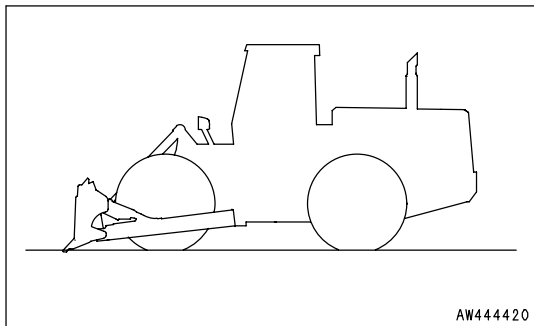

AW444420

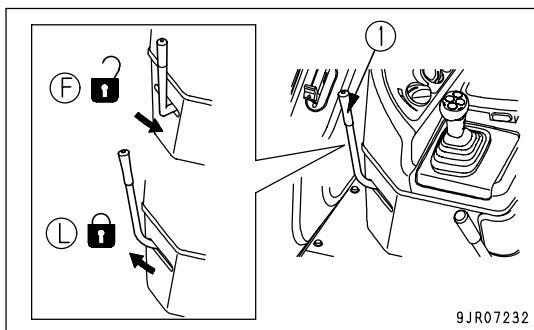

9JR07232

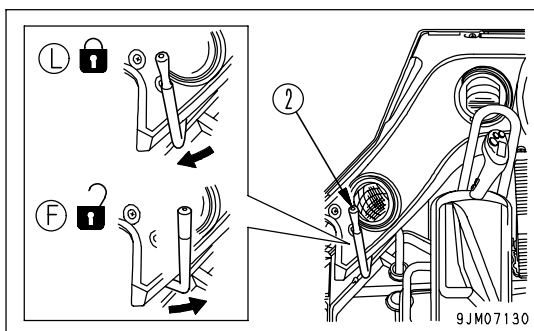

9JM07130

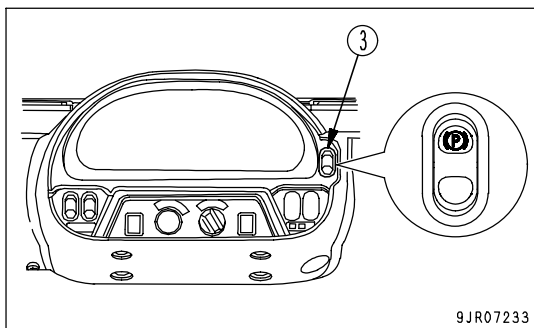

9JR07233

PRECAUTIONS WHEN TRAVELING

- Never turn the key in the starting switch to the OFF position when the machine is traveling. If the engine stops when the machine is traveling, it may be impossible to operate the steering, and this may lead to serious personal injury or death. If the engine stops, depress the brake pedal immediately to stop the machine.
- When traveling or carrying out operations, always keep a safe distance from people, structures, or other machines to avoid coming into contact with them.
- When traveling on flat ground, keep the work equipment at height (A) 50 - 60 cm (20 - 24 in) above the ground. If the work equipment is too close to the ground surface, the work equipment may contact the ground and cause the machine to tip over. It is necessary to operate the work equipment control lever, stop the machine first, then operate the control lever.
- Avoid traveling over obstacles when possible. If the machine has to travel over an obstacle, keep the work equipment close to the ground and travel at low speed. There is more danger of the machine tipping over to the left or right than tipping over to the front or rear, so do not travel over obstacles which make the machine tilt strongly to the left or right sides.
- When traveling on rough ground, travel at low speed and do not operate the steering suddenly. There is danger that the machine may turn over. The work equipment may hit the ground surface and cause the machine to lose its balance, or may damage the machine or structures in the area.
- When using the machine, to prevent personal injury caused by damage to the work equipment or by the machine overturning due to overloading, do not exceed the permitted performance of the machine or the maximum permitted load for the structure of the machine.
- When passing over bridges or structures, check first that the structure is strong enough to support the weight of the machine.
- When operating in tunnels, under bridges, under electric wires, or other places where the height is limited, operate slowly and be extremely careful not to let the machine body or work equipment hit anything.
- If you drive the machine at high speed continuously for a long time, the tires will overheat and the internal pressure will become abnormally high. This may cause the tires to burst. If a tire bursts, it produces a large destructive force, and this may cause serious injury or death.
If you are going to travel continuously, please consult your Komatsu distributor.
- When the machine is traveling on flat ground or down a slope, NEVER set the direction selector switch to the Neutral position. Always set it to a transmission speed range.
 - If the transmission is at neutral, the engine brakes will not work, and this creates a dangerous situation.
 - It may also cause damage to the transmission or other parts of the power train, and this may lead to serious personal injury or death.

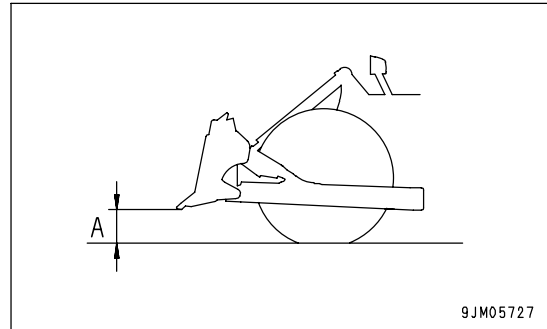

TWO WORKERS FOR MAINTENANCE WHEN ENGINE IS RUNNING

To prevent personal injury, do not carry out maintenance with the engine running. If maintenance must be carried out with the engine running, carry out the operation with at least two workers and do as follows.

- One worker must always sit in the operator's seat and be ready to stop the engine at any time. All workers must maintain contact with the other workers.
- When carrying out operations near the fan, fan belt, or other rotating parts, there is a hazard of being caught in the parts, so be careful not to come close.
- Never drop or insert tools or other objects into the fan, fan belt, or other rotating parts. There is danger that they may contact the rotating parts and break or be sent flying.

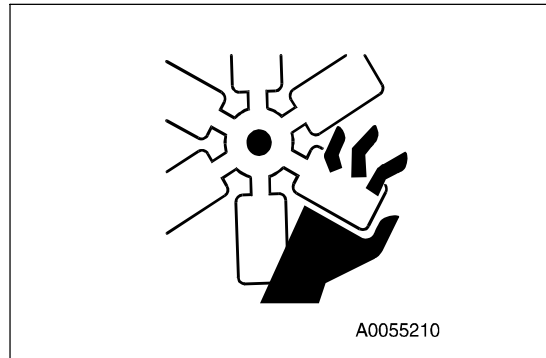

- Lower the work equipment completely to the ground, then set work equipment lock lever (1) and steering lock lever (2) to lock position (L) to prevent the machine from moving.

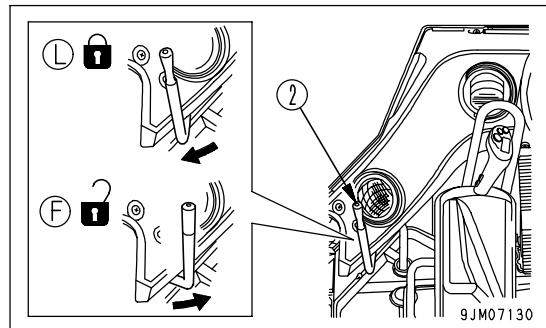
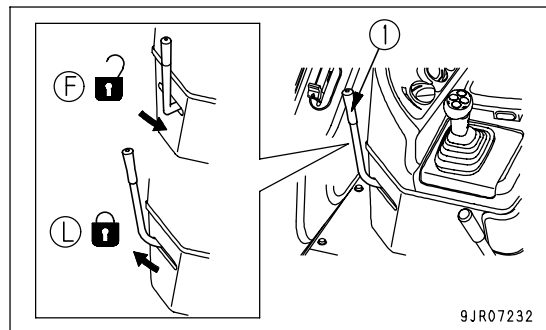

- Turn parking brake switch (3) ON to apply the parking brake, then put blocks in front of and behind the tires to prevent the machine from moving.
- Be careful not to touch the control levers or steering equipment. If the control levers must be operated, always give a signal to your partner and have your partner withdraw to a safe place.

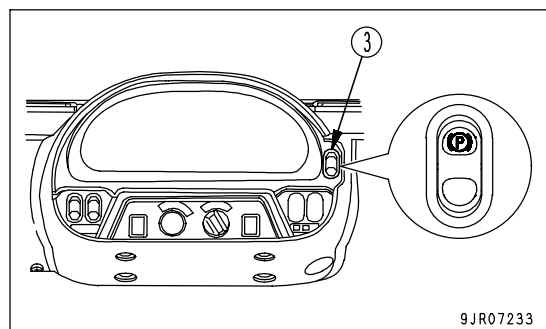

GENERAL VIEW

GENERAL VIEW OF MACHINE

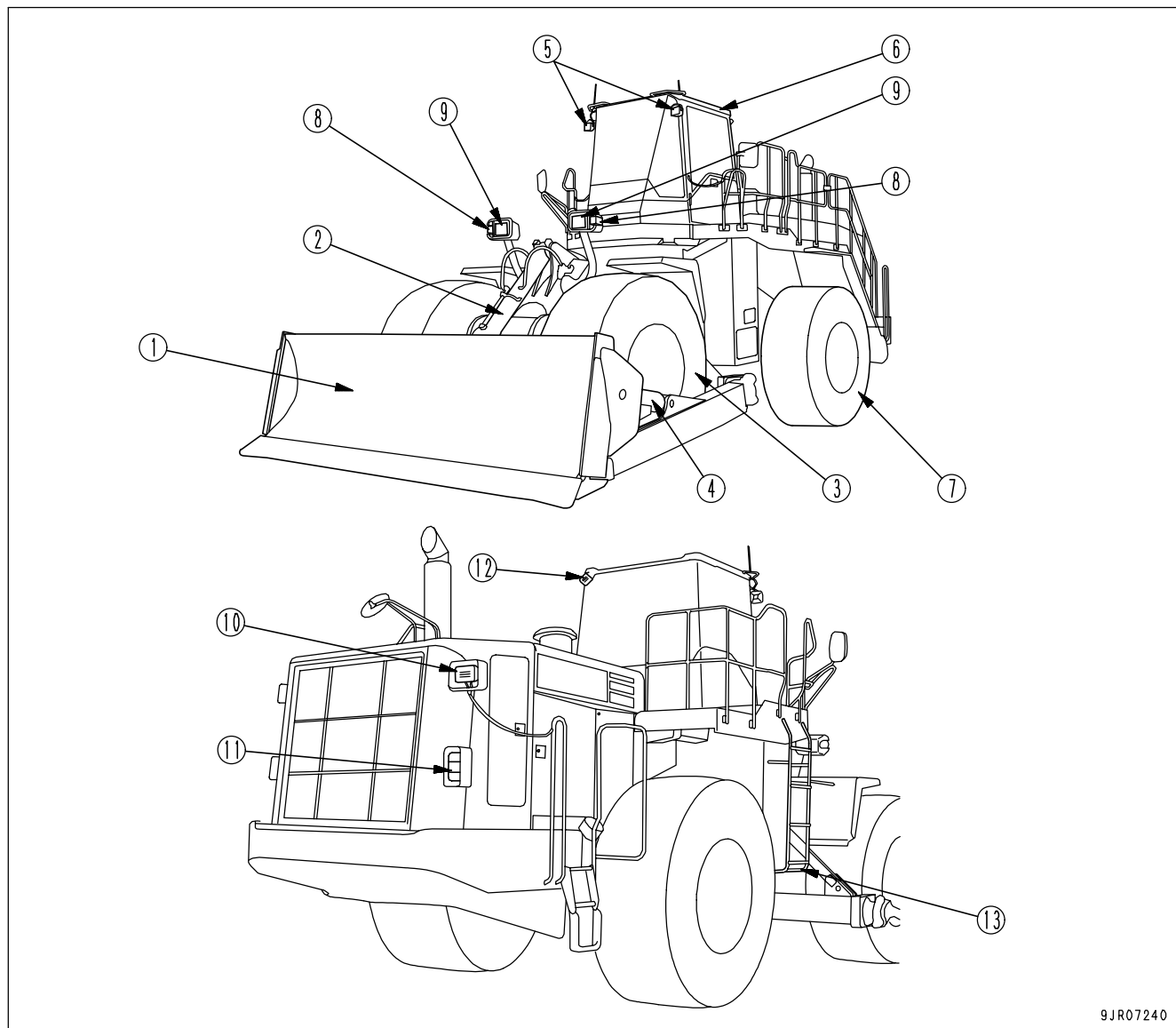

9JR07240

- (1) Blade
- (2) Lift cylinder
- (3) Front wheel
- (4) Tilt/pitch cylinder
- (5) Front working lamp
- (6) ROPS cab
- (7) Rear wheel
- (8) Turn signal lamp
- (9) Head lamp
- (10) Rear working lamp
- (11) Rear combination lamp
- (12) Step lamp
- (13) Emergency escape step

SERVICE METER

This display (1) shows the total number of hours that the machine has been working.

If the engine is running, the service meter advances even if the machine is not being operated.

The service meter advances 1 for every hour of operation, regardless of the engine speed.

Even if the starting switch is OFF, the service meter is displayed on the top line if the top (◇) portion of the machine monitor mode selector switch 1 is kept pressed.

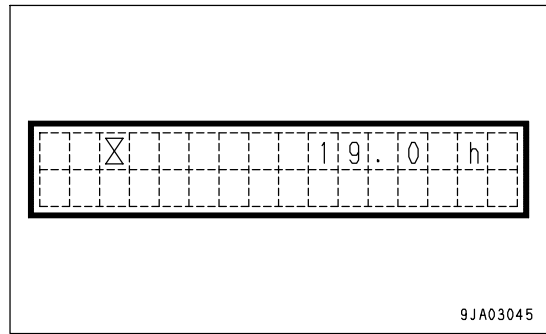

9JA03045

NOTICE

When the starting switch is at the OFF position, if the service meter is displayed even though the top (◇) of machine monitor mode selector switch 1 is not being pressed, there is probably a failure in the machine, so please contact your Komatsu distributor for inspection.

ACTION CODE DISPLAY



If action code E03 is displayed, stop the machine immediately and check the failure code. For details, see "FAILURE CODE DISPLAY (PAGE 3-14)".

Inform your Komatsu distributor of the failure code and ask for repairs.

If there is a failure on the machine, or it is necessary to change the method of operation, or if inspection or maintenance must be carried out, action code E01, E02, or E03 is displayed on the character display in display portion (2).

If different failures occur at the same time, the action code for the more serious problem is displayed.

The level of seriousness is as follows, starting with the most serious: E03, E02, E01.

In the case of action codes E02, and E03, the alarm buzzer sounds intermittently and the central warning lamp lights up.

If action codes E01, E02, or E03 are displayed on the character display, stop operations, check the content of the display, and take the following action.

E03: When this code is displayed, stop the machine immediately, check the failure code, and contact your Komatsu distributor for repairs.

REMARK

- "E03" is displayed on the top line of the character display, and "CHECK RIGHT NOW" and "CALL" are displayed on the bottom line in turn for 3 seconds each.
- The telephone number to call is displayed on the right side of the "CALL" display. If no telephone number has been set, no display is given. For details of the method of inputting the telephone number, see "INPUT METHOD FOR TELEPHONE NUMBER (PAGE 3-38)".

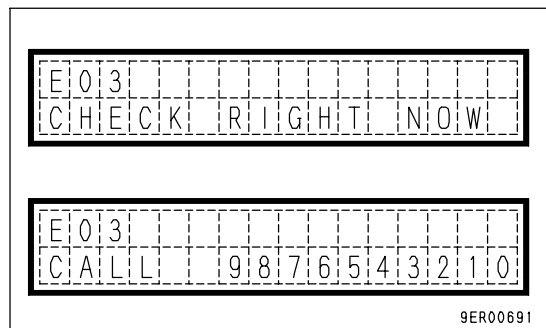

9ER00691

FUEL LEVEL CAUTION LAMP

This lamp (5) lights up when the amount of fuel remaining in the fuel tank goes below approx 120 liters (31.7 US gal).

If the lamp lights up, check the fuel level immediately and add fuel. For details, see "CHECK FUEL LEVEL, ADD FUEL (PAGE 3-126)".

REMARK

Even when the fuel level caution lamp lights up, action code "E02" is not displayed on the character display.

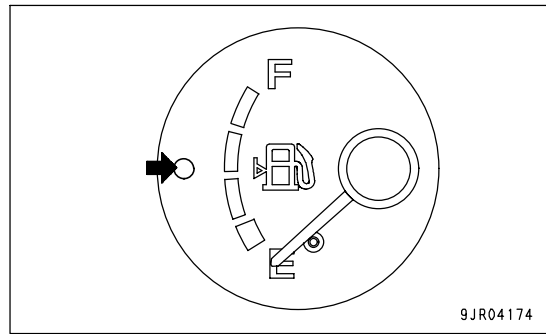
**MODULATION CLUTCH TEMPERATURE CAUTION LAMP**

This lamp (6) warns the operator that the modulation clutch temperature has risen.

When carrying out the check before starting (starting switch at ON position, engine stopped), the lamp does not light up.

During operation (engine running)

If the modulation clutch temperature rises, the modulation clutch temperature caution lamp lights up.

If the temperature rises further, the central warning lamp also lights up and the alarm buzzer sounds intermittently.

The central warning lamp lights up and "E02 MOD/C OVERHEAT" is displayed on the character display, so stop the machine and run the engine under no load at a mid-range speed until the lamp goes out.

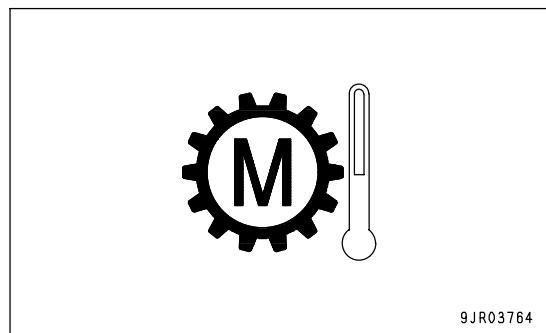
**REMARK**

If the left brake pedal is depressed, the modulation clutch will slip and the temperature will rise because of the friction.

(When the RPM set system is actuated, if the left brake pedal is depressed, the modulation clutch is disengaged, so the modulation clutch does not slip.)

In addition, if the drive force control dial is throttled down, the modulation clutch will slip and the temperature will rise because of the friction.

In particular, if the drive force control dial is throttled down and digging operations are carried out in 1st, carry out the operation from the start of pushing to completion of scooping up within 10 seconds in order to prevent overheating of the clutch.

E.C.S.S. PILOT LAMP

This lamp (16) is not active.

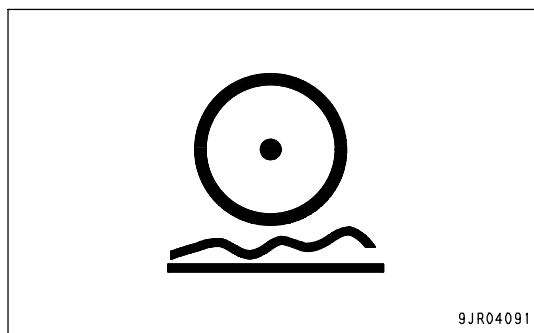
**ECONOMY OPERATION DISPLAY LAMP**

This lamp (17) lights up to show that the economy mode is being used (economy operation).

It does not light up when the setting is power mode.

This lamp is interconnected with the accelerator pedal and lights up or goes out according to the operation of the accelerator pedal, so use it as a guideline for economy operation.

**SEMI AUTO DIGGING PILOT LAMP**

This lamp (18) is not active.

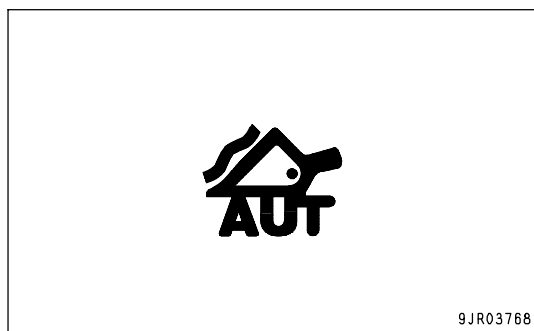

4. Press the (◇) portion of the machine monitor mode selector switch 1. The screen switches to the display shown on the right and it becomes possible to adjust the brightness.
5. Press the (>) or (<) portion of the machine monitor mode selector switch 2 to adjust the brightness between L and H (7 levels).
6. After selecting the desired brightness, press the (■) portion of the machine monitor mode selector switch 1. The brightness is set and the screen returns to the previous screen.
7. After completing the operation, press the (■) portion of the machine monitor mode selector switch 1 twice or turn the starting switch OFF.

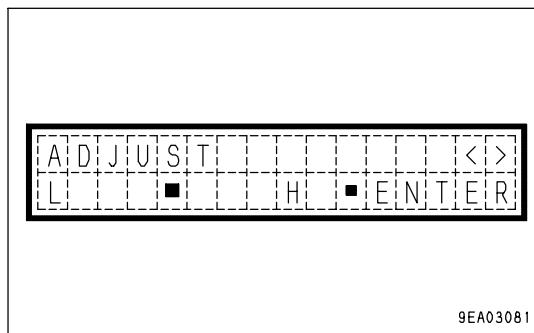

EMERGENCY PARKING BRAKE CANCEL SWITCH



When the emergency parking brake cancel switch is released, the machine may move.

When releasing the emergency parking brake switch, see "METHOD OF RELEASING BRAKE BY USING EMERGENCY PARKING BRAKE CANCEL SWITCH (PAGE 3-176)".

If the engine will not start for some reason, use this switch (14) to release the parking brake. Please contact your Komatsu distributor to have the brake released.

Position (a): Release

Position (b): Normal position

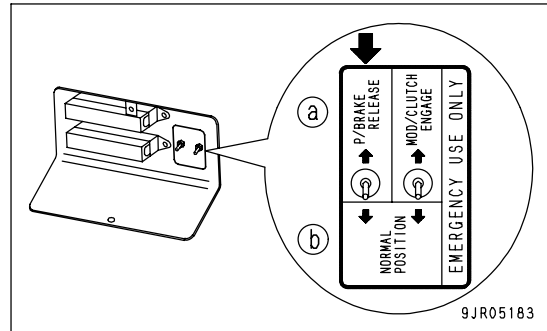

EMERGENCY MODULATION CLUTCH DIRECT CONNECTION SWITCH

If the modulation clutch will not engage for some reason and the machine cannot travel, use this switch (15) to engage the clutch as an emergency measure.

Please contact your Komatsu distributor to have the clutch engaged.

Position (a): Engaged

Position (b): Normal position

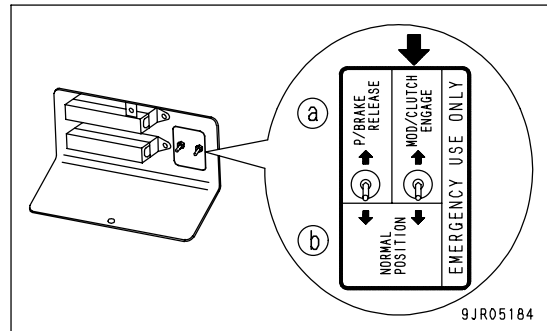

SETP LAMP

Use this switch (3) to turn step lamp (A) ON-OFF when getting on or off the machine.

REMARK

- There are two step lamp switches: one by the steps and one at the top left inside the operator's compartment. Either of these switches can be used to turn the step lamp ON-OFF.
- When the lamp is turned ON from inside the operator's compartment, it is possible to turn it OFF using the switch by the steps after going down the steps.
- The step lamp can be turned ON even when the starting switch is at the OFF position. Leaving the step lamp ON will run the battery down, so always turn it OFF when leaving the machine.

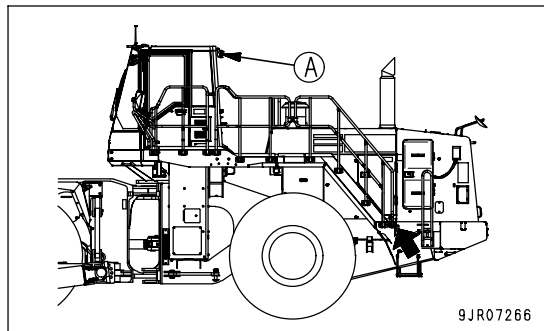
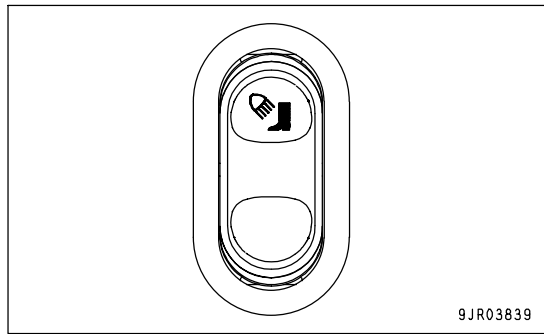

REAR HEATED WIRE GLASS SWITCH

This switch (4) turns the electricity to the heated wire glass at the rear of the operator's compartment ON-OFF when removing the mist from the glass.

Position (a): ON (removes mist from glass)

Position (b): OFF

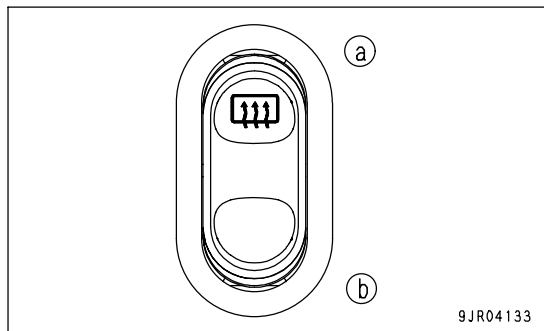

REAR WIPER SWITCH

Use this switch (5) to actuate the rear wiper at the rear of the operator's compartment.

Position (a): Washer liquid is sprayed out, wiper is operated

Position (b): Wiper is operated

Position (c): OFF

The switch automatically returns from position (a) to position (b).

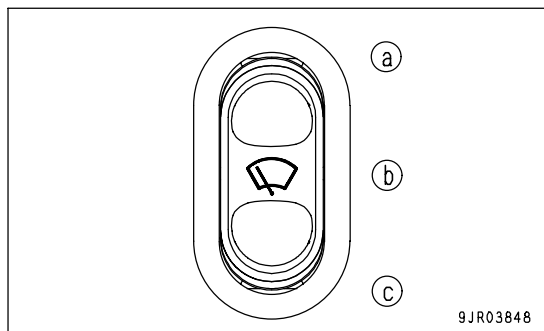

BLADE CONTROL LEVER DIRECTIONAL ADJUSTMENT LEVER



WARNING

When operating the blade control lever directional adjustment lever, be careful not to touch the blade control levers.

Use this lever (7) to move the blade control levers (right console) within a range (a) to the front and rear of 102 mm (4.0 in) (17 mm (0.7 in) x 6 stages).

In addition, when carrying out maintenance, it is also possible to move the blade control lever 52 mm (2.0 in) to the rear. (range (b))
When adjusting the blade control lever (right console), set the lever to FREE position (F) before adjusting.

When the lever is released, it returns automatically to LOCK position (L).

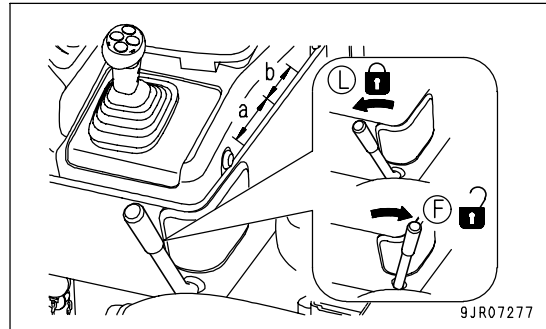

WORK EQUIPMENT LOCK LEVER



WARNING

- Always set the work equipment lock lever securely to the LOCK position when standing up from the operator's seat. If the work equipment lock lever is not securely in the LOCK condition, and blade control lever (A) is touched by mistake, it may cause serious personal injury.
- If the work equipment lock lever is not set securely to LOCK position (L), the blade may move and cause serious personal injury. Check that the work equipment lock lever is at LOCK position (L).
- When operating the work equipment lock lever, be careful not to touch blade control lever (A).

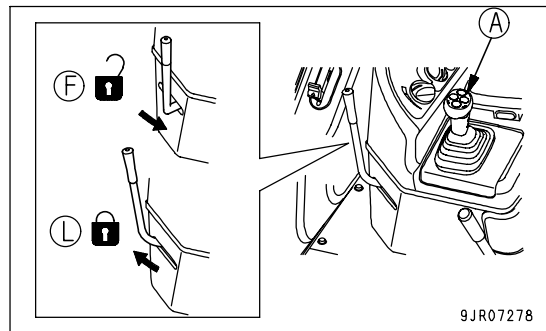

This lever (8) is a device to lock the blade control lever.
Push the work equipment lock lever to the outside to lock it.

REMARK

This lever shuts off the hydraulic circuit for the work equipment, so if it is at LOCK position (L), the blade will not move even if blade control lever (A) is operated.

DUST INDICATOR

The dust indicator is at the front of the engine hood at the rear of the operator's compartment.

The display is given in five stages according to the degree of clogging of the element.

If the air cleaner is clogged, the air cleaner clogging caution lamp on the machine monitor lights up to inform the operator that the air cleaner needs to be cleaned.

After cleaning, press the reset button to cancel the lamp.

For details of the method of cleaning, see "CLEANING OR REPLACING OUTER ELEMENT (PAGE 4-23)".

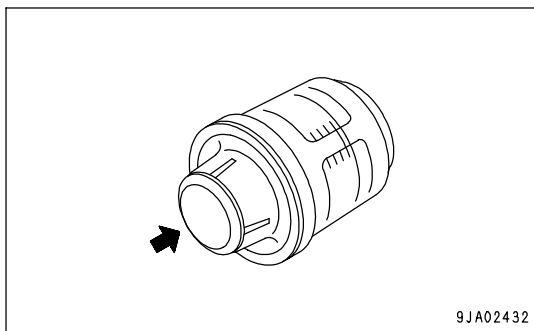
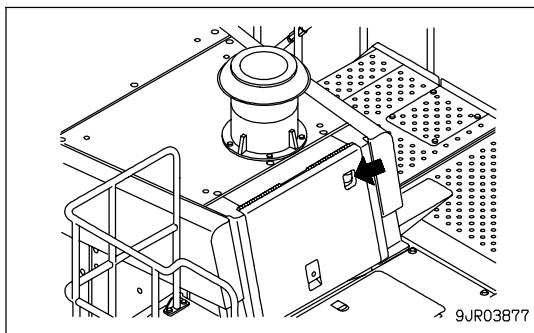

AM/FM RADIO-CASSETTE STEREO

EXPLANATION OF COMPONENTS

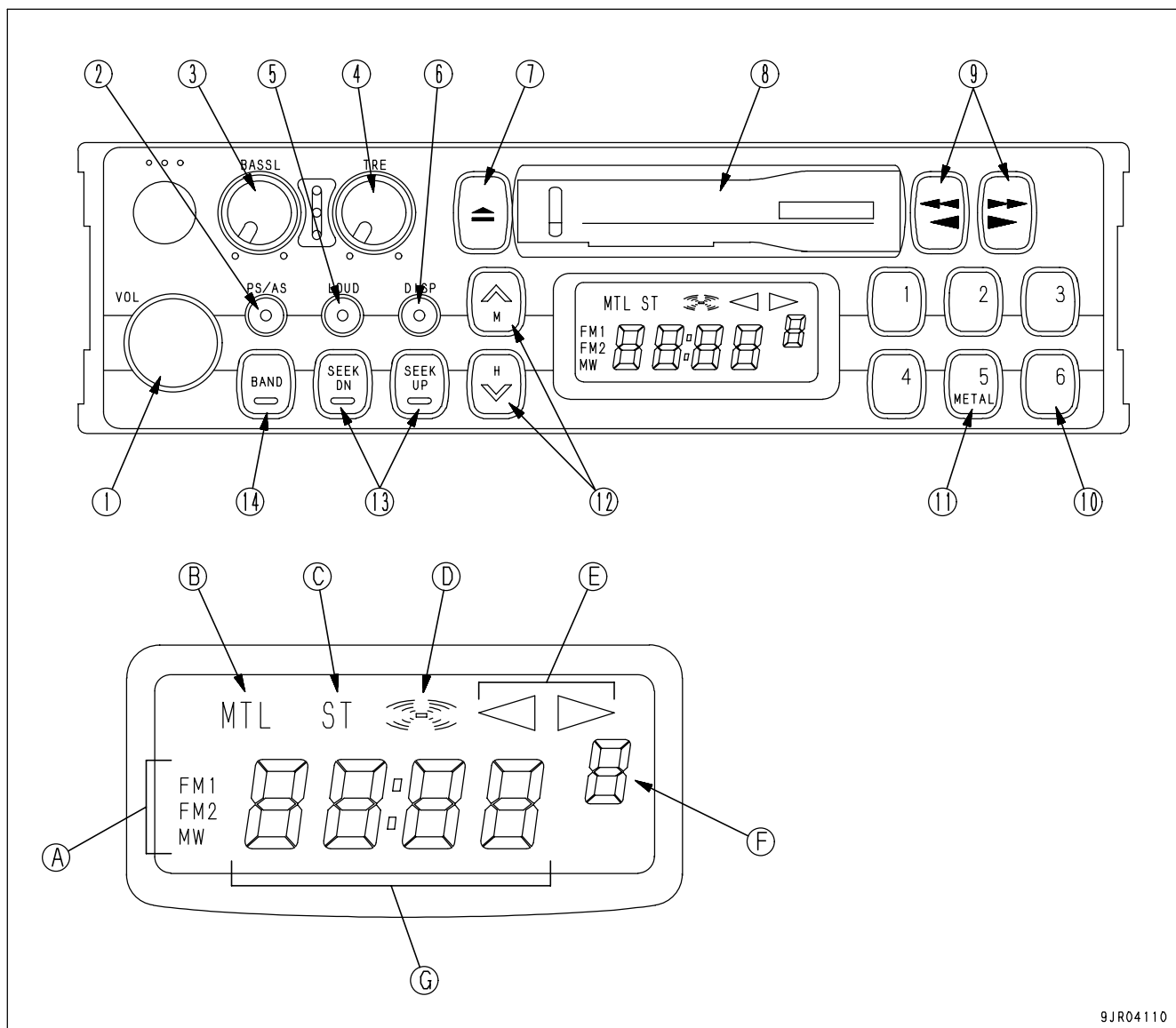

9JR04110

- | | |
|--|---|
| <ul style="list-style-type: none"> (1) Power switch/volume (2) Auto-store/preset scan button (3) Bass control knob (4) Treble control knob (5) Loudness button (6) Time/radio display selector button (7) Tape eject button | <ul style="list-style-type: none"> (8) Cassette door (9) Fast forward, rewind buttons (10) Preset buttons (11) Metal tape button (12) Manual tuning buttons (13) Seek tuning buttons (14) Band selector button |
| <ul style="list-style-type: none"> (A) Band display (B) Metal tape display (C) FM stereo reception display (D) Loudness display | <ul style="list-style-type: none"> (E) Tape direction display (F) Preset channel display (G) Time/frequency display |

FAN SWITCH

Use this switch (2) to regulate the air flow manually.
 When the fan switch is pressed, the lamp at the top of the auto switch goes out to show that operation has changed to manual.
 The air flow can be set to one of six levels.

- Press the "^" switch to increase the air flow; press the "v" switch to decrease the air flow.
 When doing this, it is possible to check the new set air flow on the monitor display.

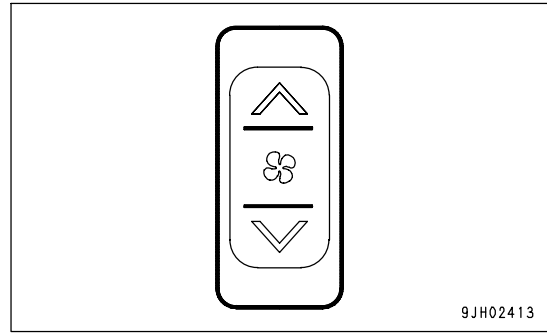

<Monitor display and air flow>

Liquid crystal display	Air flow
	Air flow "low"
	Air flow "medium 1"
	Air flow "medium 2"
	Air flow "medium 3"
	Air flow "medium 4"
	Air flow "high"

TEMPERATURE CONTROL SWITCH

Use this switch (3) to regulate the temperature inside the cab. It can be set to a range from 18°C - 32°C (64.4°F - 89.6°F).

- Press the "^" switch to increase the set temperature; press the "v" switch to decrease the set temperature.
 When doing this, it is possible to check the new set temperature on the monitor display.
- The temperature can be set in stages of 0.5°C (0.9°F).

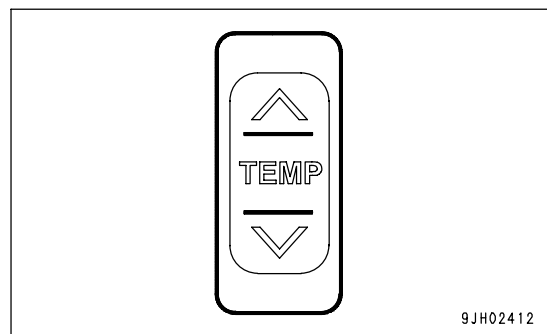

<Monitor display and the function>

Monitor display °C	Set temperature
18.0	Max. cooling
18.5 to 31.5	Adjusts temperature inside cab to set temperature
32.0	Max. heating

During the rainy season or other times of high humidity, if it is desired to carry out dehumidification, turn air conditioner switch (8) ON.

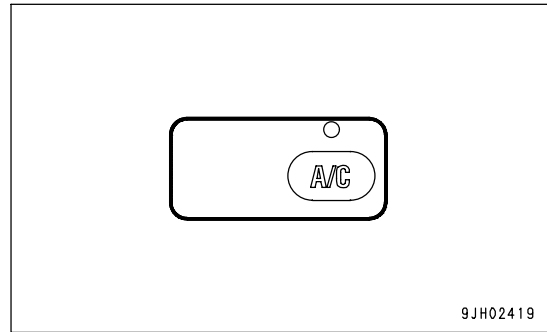

9JH02419

USE AIR CONDITIONER WITH CARE

NOTICE

- When running the air conditioner, always start with the engine running at low speed. Never start the air conditioner when the engine is running at high speed. It will cause failure of the air conditioner.
- If water gets into the control panel or sunlight sensor, it may lead to unexpected failure, be careful not to let water get on these parts. In addition, never bring any flame near these parts.
- For the auto function of the air conditioner to work properly, always keep the sunlight sensor clean and do not leave anything around the sunlight sensor that may interfere with its sensor function.

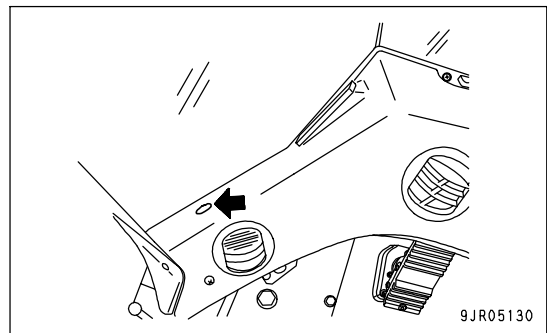

9JR05130

VENTILATION

- If you smoke when the air conditioner is on, the smoke may start to hurt your eyes, so open the window and turn the lever to FRESH for a while to remove the smoke while continuing the cooling.
- When using the air conditioner for a long time, carry out ventilation and cooling once every hour.

TEMPERATURE CONTROL

When the cooler is on, set the temperature so that it feels slightly cool when entering the cab (5 or 6 °C (9 or 10.8 °F) lower than the outside temperature). This temperature difference is considered to be the most suitable for your health, so always be careful to adjust the temperature properly.

AIR CONDITIONER MAINTENANCE

When carrying out inspection and maintenance of a machine equipped with an air conditioner, carry out the inspection and maintenance in accordance with the maintenance schedule chart. For details, see "MAINTENANCE SCHEDULE CHART (PAGE 4-19)".

CLICK HERE TO **DOWNLOAD** THE COMPLETE MANUAL

- Thank you very much for reading the preview of the manual.
- You can download the complete manual from: www.heydownloads.com by clicking the link below



- Please note: If there is no response to CLICKING the link, please download this PDF first and then click on it.

CLICK HERE TO **DOWNLOAD** THE COMPLETE MANUAL

CHECK FUEL PRE-FILTER, DRAIN WATER

**WARNING**

- After the engine has stopped, all parts are at high temperature, so never drain the water or remove the element cup immediately. Always wait for all parts to cool down before carrying out the operation.
- Do not bring any flame or fire close.

1. Open the engine side cover on the right side of the chassis.
2. Check if any water is accumulated in cap (1) at the bottom of the filter.

If water is accumulated in cup (1), drain the water as follows.

Prepare a container to catch the water.

3. Pull drain hose (2) out from clamp (3).
4. Put a container under drain hose (2) to catch the drained water.
5. Loosen plug (4) and drain the water.
6. When fuel starts to come out from drain hose (2), tighten plug (4) immediately.

Tightening torque: 0.2 to 0.45 Nm {0.02 to 0.046 kgm, 0.1 to 0.3 lbft}

7. Return drain hose (2) to clamp (3).
8. After completing the water drain operation, bleed the air. Use the same procedure as when replacing the fuel filter cartridge. For details of the method for bleeding the air, see "BLEEDING AIR FROM FUEL CIRCUIT (PAGE 4-45)".

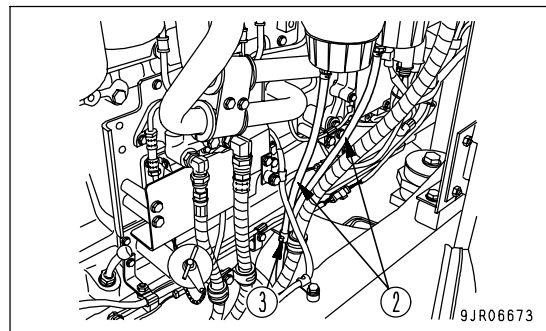
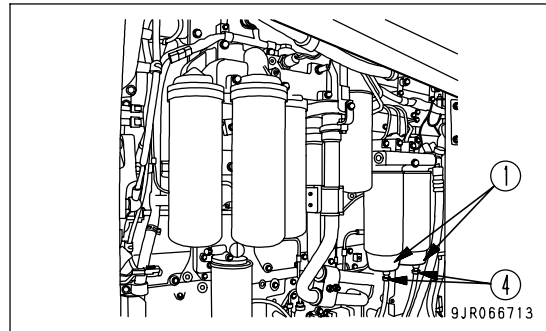

ADJUST SEAT BELT**WARNING**

- Before fitting the seat belt, check that there is no problem in the belt mount bracket or mounting belt. If it is worn or damaged, replace the seat belt.
- Even if there are no signs of damage, replace belts in accordance with the following schedule:
5 years after the date of seat belt manufacture, or every 3 years after the start of actual usage, whichever date comes first.
- Always wear the seat belt during operations.
- Fit the seat belt so that it is not twisted.

REMARK

The date of seat belt manufacture attached to the seat belt is the start of the 5-year period. It is not the start of the 3-year period of actual usage.

FASTENING AND REMOVING BELT

Fasten the belt so that it is tight without being too tight.

1. Sit on the seat, depress the brake pedal fully, and adjust the seat so that your back is pressed against the backrest.
2. Sit on the seat, pull the right belt, then insert tongue (1) securely into buckle (2) until a click is heard. Pull the belt to check that it is firmly locked.
3. When removing the belt, press the red button in buckle (2) to free the belt.

Fit the belt so that it follows your body and is not twisted.

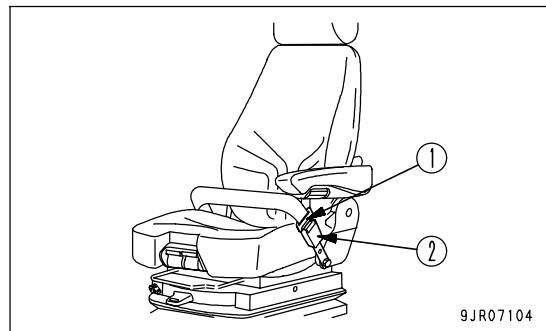

MOVING THE MACHINE (DIRECTIONAL, SPEED), STOPPING THE MACHINE



WARNING

- Always remove the frame lock bar before traveling. If it is not removed, the steering will not work and this may lead to serious personal injury.
- When moving the machine off, check that the surrounding area is safe, then sound the horn and start the machine.
- Do not let any person enter the area around the machine.
- Remove any obstacles from the travel path.
- The rear of the machine is a blind spot, so when traveling in reverse, be particularly careful to check that it is safe.
- When starting the machine off on a slope, depress the left brake pedal, then depress the accelerator pedal and slowly let the left brake pedal back to allow the machine to move off. This will prevent the machine from running back down the slope.

PREPARATIONS FOR MOVING MACHINE

1. Check that warning pilot lamp (1) is not lighted up.

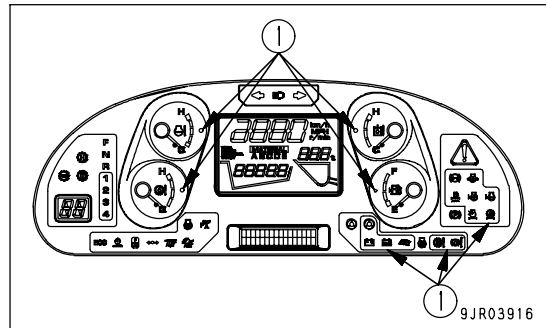
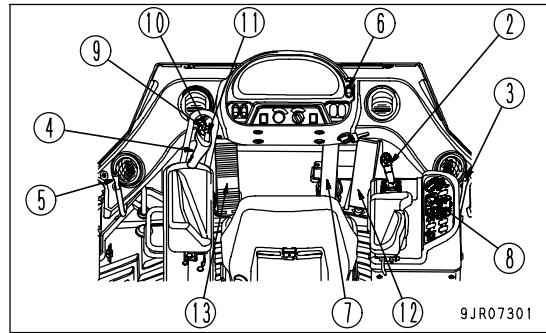

OPERATION OF WORK EQUIPMENT

WARNING

- When standing up from the operator's seat, always set the work equipment lock lever (2) securely to the LOCK position. If the work equipment lock lever (2) is not locked, and blade control lever (1) is touched by mistake, this may lead to serious personal injury.
- If the work equipment lock lever (2) is not set securely to LOCK position (L), the blade may move and cause serious personal injury. Check that the work equipment lock lever (2) is at the position shown in the diagram.
- When pulling the work equipment lock lever (2) up or pushing it down, be careful not to touch blade control lever (1).

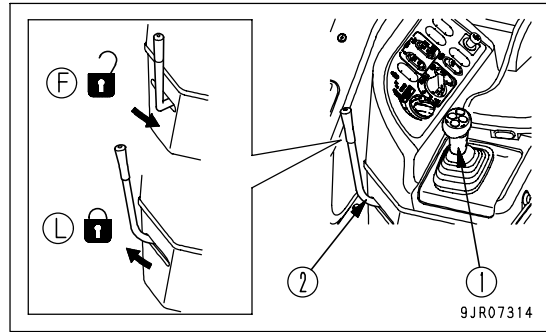

Work equipment lock lever (2) is a lock device for blade control lever (1). Push the work equipment lock lever to the outside to apply the lock.

REMARK

This lever locks the hydraulic circuit for the work equipment electrically, so if it is set to LOCK position (L), the blade will not move even if blade control lever (1) is operated.

Blade control lever (1) can be used to operate the blade as follows.

BLADE LIFT OPERATION

Position (a): RAISE

Position (b): HOLD

The blade is kept in the same position

Position (c): LOWER

Position (d): FLOAT

The blade moves freely under external force.

If the lever is released at this position, it will not return to the HOLD position, so return it manually.

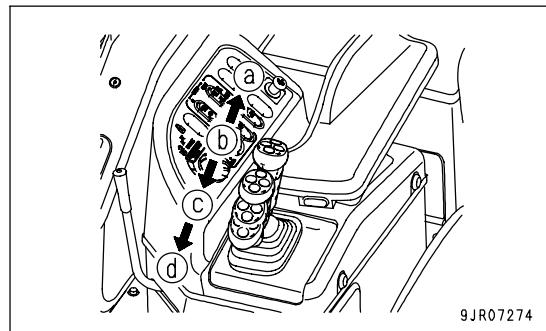

REMARK

If the lever is released at position (a) or (c), the lever will return to the HOLD position.

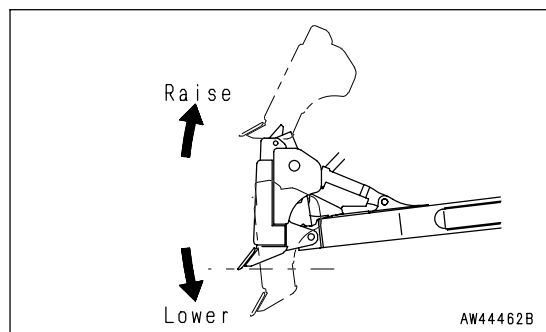

Clearing fallen stones and rocks from the operating area and maintaining the surface will extend the tire life and give improved economy.

- Operations on normal road surface: Set the inflation pressure to slightly higher than the table below.
- Operations on soft ground: Set the inflation pressure to the midpoint in the table below.
- Operations on sandy ground: Set the inflation pressure to slightly lower than the table below.

If the deflection of the tire is excessive, raise the inflation pressure within the limits given in the table to give a suitable deflection (see deflection ratio).

Tire size (Pattern)	H Free Height (mm)	Inflation pressure MPa (kgf/cm ² , PSI)		
		Soft ground (sandy ground)	Normal road	When shipped from factory
35/65-33-24PR (L4 Rock)	529	0.34 - 0.39 (3.5 - 4.0, 49.7 - 56.8)	0.34 - 0.39 (3.5 - 4.0, 49.7 - 56.8)	Front tire: 0.34 (3.5, 49.7) Rear tire: 0.39 (4.0, 56.8)
35/65-33-24PR (L5 Rock)	529	0.34 - 0.39 (3.5 - 4.0, 49.7 - 56.8)	0.34 - 0.39 (3.5 - 4.0, 49.7 - 56.8)	

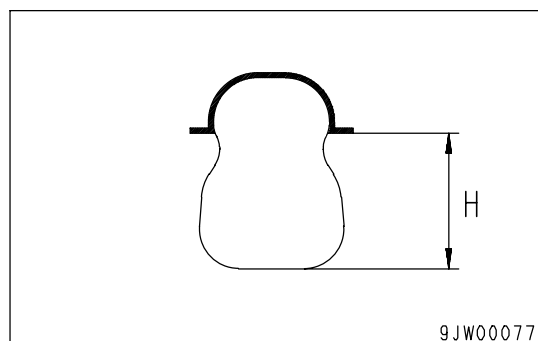

LONG-TERM STORAGE

BEFORE STORAGE

When keeping in long-term storage (more than one month), store as follows.

- Clean and wash all parts, then store the machine indoors. If the machine has to be stored outdoors, select level ground and cover the machine with a sheet.
- Completely fill the fuel tank. This prevents moisture from collecting.
- Lubricate and change the oil before storage.
- Coat the exposed portion of the hydraulic cylinder piston rod with grease.
- After shutting off the engine, wait over one minute, then turn the battery disconnect switch to the OFF position, and take out the battery disconnect switch key. Put a cover on the battery during storage.
- Lock each control lever with the lock lever.
- To prevent rust, fill with COOLANT to give a density of at least 30% for the engine coolant.

DURING STORAGE



WARNING

If it is necessary to perform the rust-prevention operation while the machine is indoors, open the doors and windows to improve ventilation and prevent gas poisoning.

- During storage, operate and move the machine for a short distance once a month so that a new film of oil will coat moving parts. At the same time, also charge the battery.
- When operating the work equipment, wipe off all the grease from the hydraulic cylinder rods.
- If the machine is equipped with an air conditioner, operate the air conditioner for 3 to 5 minutes once a month to lubricate all parts of the air conditioner compressor. Always run the engine at low idle when doing this. In addition, check the refrigerant level twice a year.

AFTER STORAGE

NOTICE

If the machine has been stored without carrying out the monthly rust-prevention operation, consult your Komatsu distributor before using it.

When using the machine after long-term storage, do as follows before using it.

- Wipe off the grease from the hydraulic cylinder rods.
- Add oil and grease at all lubrication points.
- When the machine is stored for a long period, moisture in the air will mix with the oil. Check the oil before and after starting the engine. If there is water in the oil, change all the oil.

METHOD FOR LOWERING WORK EQUIPMENT WHEN ENGINE HAS STOPPED



WARNING

Check that the surrounding area is safe, then lower the work equipment.

1. Turn starting switch key to the ON position.

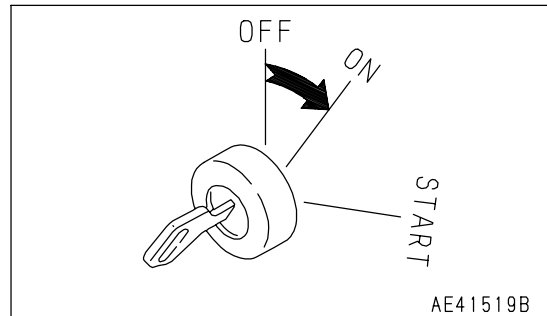

2. Turn the work equipment lock lever to FREE position (F).

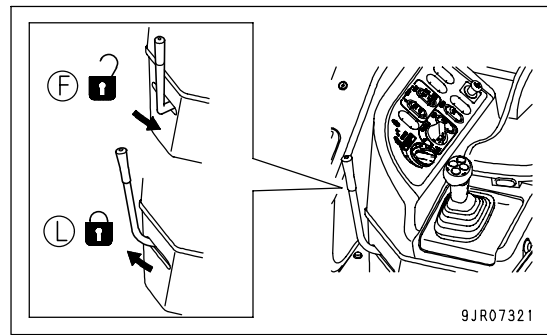

3. Operate the blade control lever to lower the blade to the ground.

4. Set the work equipment lock lever to the LOCK position (L) securely.

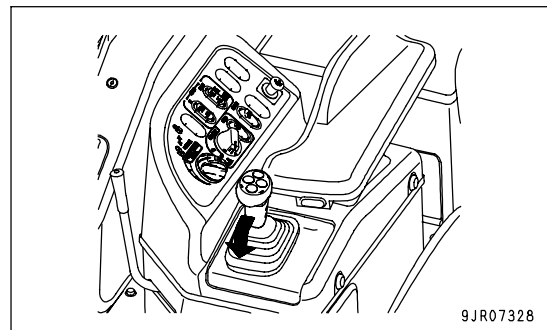

5. Turn the key in the starting switch to the OFF position and stop the engine.

REMARK

Carry out this operation within two minutes after the engine is stopped. If the machine is left after the engine has stopped, the pressure in the accumulator will go down and it will be impossible to lower the work equipment.

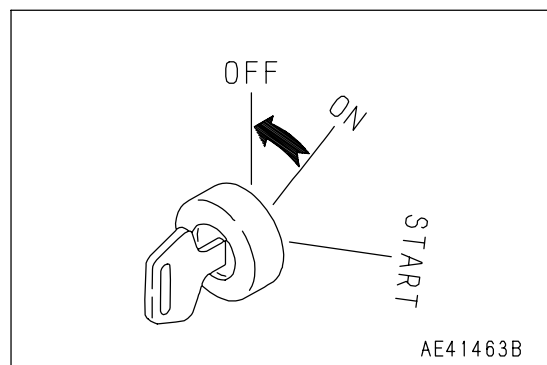

GREASE

- Grease is used to prevent seizure and noises at the joints.
- This construction equipment is used under heavy-duty conditions. Always use the recommended grease and follow the change intervals and recommended ambient temperatures given in this Operation and Maintenance Manual.
- Grease fittings not listed in the inspection and maintenance section are grease fittings that are used at the time of overhaul, so there is no need to grease these points.
When using the machine after it has been in storage for a long time, carry out greasing if there is any stiffness or screeching.
- Always wipe off all of the old grease that is pushed out when greasing.
Be particularly careful to wipe off the old grease in places where sand or dirt sticking in the grease would cause wear of the rotating parts.

PERIODIC REPLACEMENT OF SAFETY CRITICAL PARTS

To ensure safety at all times when operating or driving the machine, the user of the machine must always carry out periodic maintenance. In addition, to further improve safety, the parts in the safety-critical parts list on the next page must also be replaced at the specified interval. These parts are particularly closely connected to safety and fire prevention, so please contact your Komatsu distributor to have them replaced.

Material quality of these parts can change as time passes and they are likely to wear out or deteriorate. However, it is difficult to determine the extent of wear or deterioration at the time of periodic maintenance. Hence, it is required to replace them with new ones regardless of their condition after a certain period of usage. This is important to ensure that these parts maintain their full performance at all times.

Furthermore, should anything abnormal be found on any of these parts, replace it with a new one even if the periodic replacement time for the part has not yet arrived.

If any of the hose clamps show deterioration like deformation or cracking, replace the clamps at the same time as the hoses.

Also perform the checks with hydraulic hoses which need to be replaced periodically. Tighten all loose clamps and replace defective hoses, as required.

When replacing hoses, always replace O-rings, gaskets, and other such parts at the same time.

If the jobsite changes frequently and it is difficult to manage the density of the coolant, a density of up to 50% can be permitted.

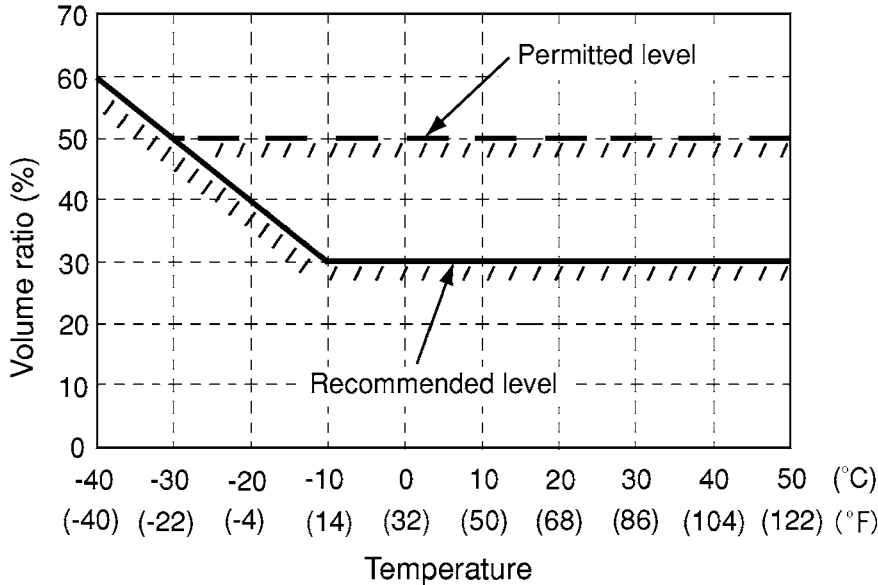

! WARNING

- COOLANT is toxic. When open the drain valve, be careful not to get coolant on you. If it gets in your eyes, flush your eyes with large amount of fresh water and see a doctor at once.
- When changing the coolant or when handling the coolant containing COOLANT that has been drained during repair of radiator, please contact your Komatsu distributor or request a specialist company to carry out the operation. COOLANT is toxic. Do not let it flow into drainage ditches or spray it onto the ground surface.

COOLANT is already diluted with distilled water, so it is not flammable. (For details of the distilled water, see "COOLANT AND WATER FOR DILUTION (PAGE 4-5)"). Check the density with a COOLANT tester. Prepare a container whose capacity is larger than the specified coolant volume to catch drained coolant. Prepare a hose to use when filling with coolant.

1. Stop the machine in a horizontal place.
2. Stop the engine.
3. Open engine inspection cover (1).

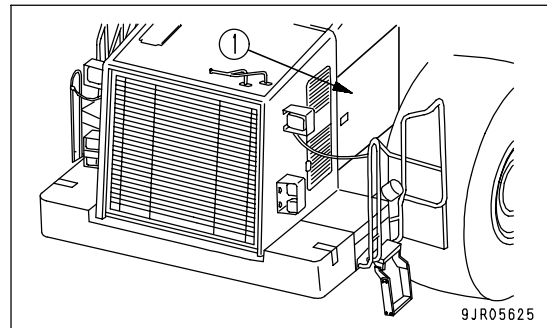

12. Install fan nets (3), then tighten the bolts of the fan nets.
13. Close radiator grill (2), then tighten bolts (1).

REVERSE, REPLACE CUTTING EDGE, END BIT



WARNING

It is dangerous if the blade moves by mistake when the turning or replacing operation is being carried out. Set the blade in a stable condition, stop the engine, then lock the blade control lever securely with the work equipment lock lever.

Reverse or replace end bit (1) and cutting edge (2) before they wear down to the end face of the blade.

1. Raise the blade to a convenient height, and put blocks under the blade to prevent it from coming down. Raise the blade so that the bottom is horizontal.
2. Operate the work equipment lock lever to the LOCK position.
3. Measure the wear of the end bit and cutting edge in accordance with the wear standards given below.

Wear standards

[Unit: mm (in)]

Item		Judgment standard	
No.	Measurement position	Standard dimension	Permissible limit
1	Height of outside of end bit	A	254 (10.0) 215 (8.5)
		B	315 (12.4) 235 (9.3)
2	Width of end bit	A	493 (19.4) 392 (15.4)
		B	492 (19.4) 392 (15.4)
3	Height of inside of end bit	A	254 (10.0) 215 (8.5)
		B	254 (10.0) 215 (8.5)
4	Height of cutting edge (Distance from center of bolt mounting hole to end face)	127 (5.0)	87 (3.4)

A: Straight dozer (straight end bit)
 B: Straight dozer (angle end bit)

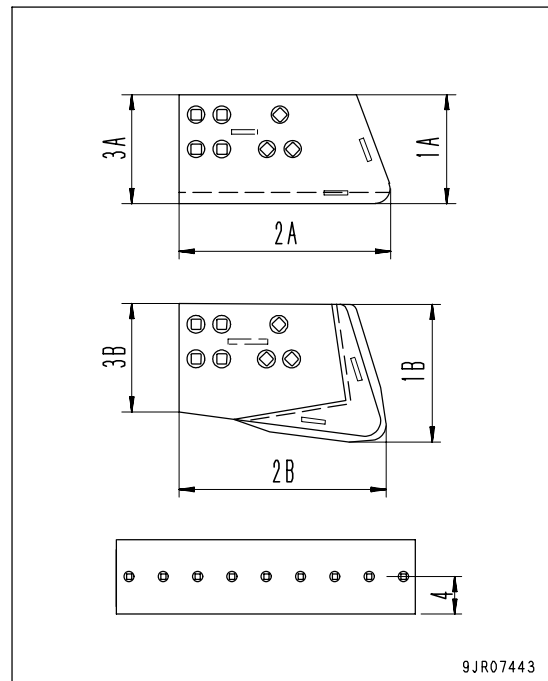

9JR07443

4. Remove bolt (3) and nut (4), then replace end bit (1) with new one. If the bolt and nut are worn out, replace with new one. Tightening torque of mounting bolt: 863 to 941 Nm (88 to 96 kgm , 637 to 694 lbft)

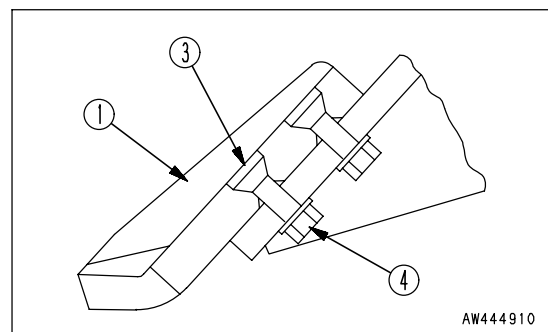

AW444910

REMARK

- The electric priming pump switch has a built-in timer, and this actuates and stops the pump automatically.
- While the lamp is flashing, the electric priming pump will stop, but this does not indicate any abnormality.
- If the switch is turned to the OFF position when the lamp is lighted up, the lamp will go out and the electric priming pump will stop.

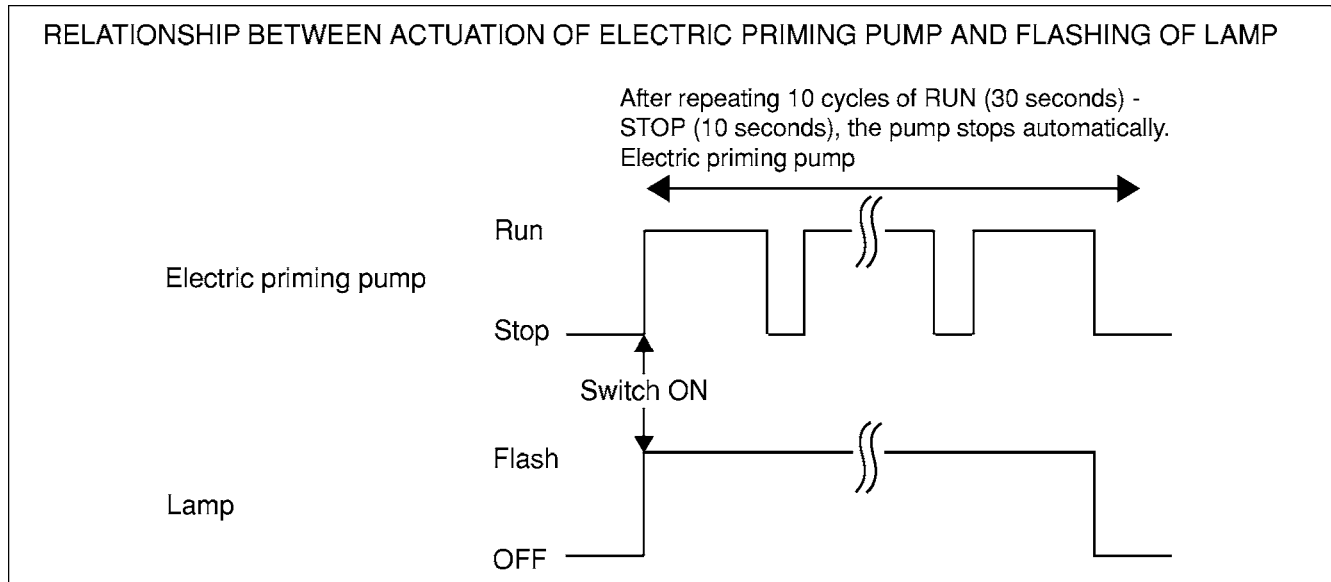

4. When the specified time (approx. 7 minutes) has passed, lamp (3) automatically goes out and the electric priming pump stops.
5. If the fuel has been drained from the fuel circuit, such as when the engine has run out of fuel and stopped, or maintenance has been carried out on the fuel hoses or tubes, or the supply pump has been replaced, turn the switch for the electric priming pump to the ON position again after the electric priming pump stops automatically (lamp goes out).
6. When the lamp goes out, the air bleed operation is completed.

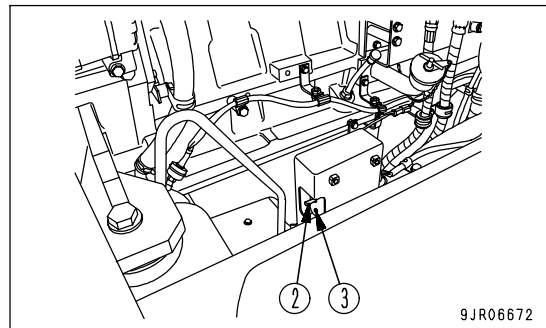

7. Close air bleed valve (1).

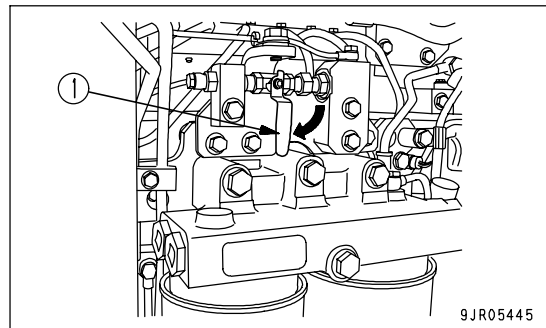

CHECK OIL LEVEL IN HYDRAULIC TANK, ADD OIL

**WARNING**

- The parts and oil are at high temperature immediately after the engine is stopped, and may cause burns. Wait for the temperature to go down before starting the work.
- When removing the oil filler cap, turn it slowly to release the internal pressure, then remove it.

1. Lower the blade to the ground, stop the engine, and wait for approx. 5 minutes.
2. Check the oil level with sight gauge (G) of the hydraulic tank.
The oil level should be near the top of sight gauge (G).

NOTICE

If the oil level is above the top of sight gauge (G), stop the engine, wait for the hydraulic oil to cool down, then drain the excess oil from the drain plug. Using the machine with excess oil in the circuit will cause damage to the hydraulic circuit or cause the oil to spurt out.

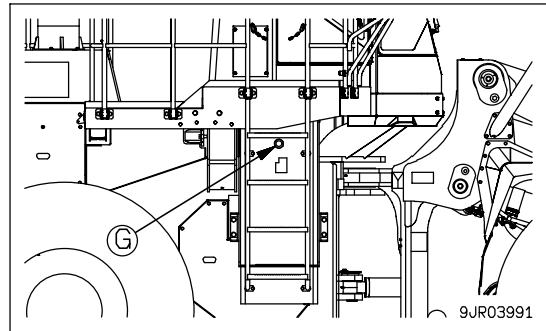

3. If the oil is not up to the top of the sight gauge, open the inspection cover above the step and add oil through oil filler port (F).

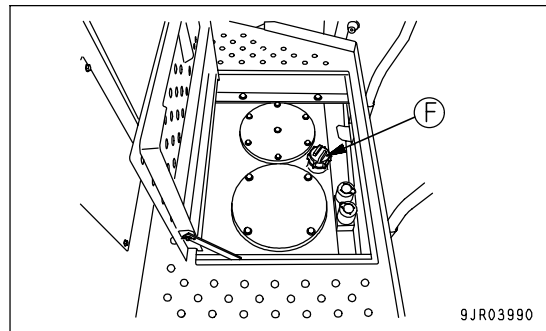

REPLACE TRANSMISSION OIL FILTER ELEMENT

**WARNING**

- The parts and oil are at high temperature after the engine is stopped, and may cause serious burns. Wait for the temperature to go down before cleaning the engine breather.
- When using compressed air, there is a hazard that dirt may be blown up and cause serious injury. Always use safety glasses, dust mask, or other protective equipment.

1. Stop the engine and wait for the temperature at all parts to go down.
2. Loosen 2 bolts at the bottom face of accumulator mount (1) on the left side of the rear frame, then remove the cover.
3. Set a container to catch the drained oil directly under drain plug (3) at the bottom of filter case (2).

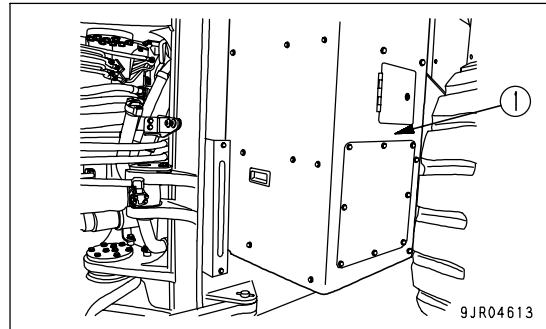

4. Remove drain plug (3) from filter case (2) and drain the oil.
5. After draining the oil, tighten drain plug (3).
6. Loosen hexagon part (4) of case (2), then remove case (2).
7. Take out element, then clean the inside of the case.
8. Replace the filter gasket and O-ring with new parts. Coat the gasket and O-ring thinly with clean engine oil before installing.
9. Assemble the new element, then set the case in position and install it.

Drain mount tightening torque: 49 to 58.8 Nm

(5 to 6 kgm, 36.2 to 43.4 lbft)

Case tightening torque: 58.8 to 78.5 Nm

(6 to 8 kgm, 43.4 to 57.9 lbft)

10. Run the engine for a short time at idling, then check that the oil is at the specified level. For details, see "CHECK TRANSMISSION OIL LEVEL, ADD OIL (PAGE 4-28)".

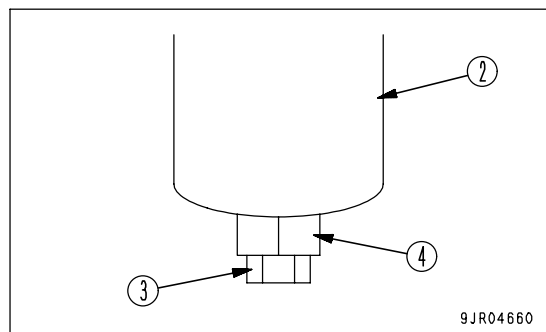
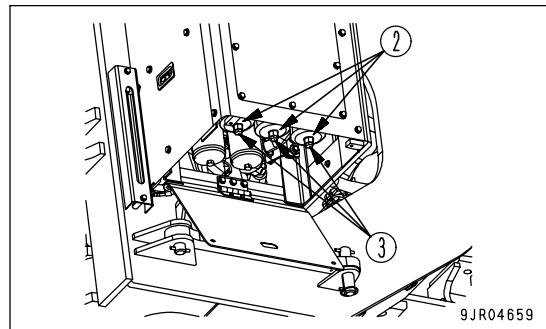

CLEAN HYDRAULIC TANK STRAINER

When changing the oil in the hydraulic tank, drain the oil from the tank and clean the strainer.

1. Lower the blade to the ground, then turn the parking brake ON (applied).
 2. Stop the engine and wait for the temperature at all parts to go down.
 3. Open the cover on the right side of the operator's compartment.
 4. Loosen bolt (1), then remove strainer cover (2).
 5. Remove strainer (5) together with rod (3) and spring (4).
 6. Remove any dirt stuck to strainer (5), then wash it in clean diesel oil or flushing oil. If strainer (5) is damaged, replace it with a new part.
 7. Install rod (3), spring (4), and strainer (5).
 8. Install cover (2).
- Replace the cover O-ring with a new part.
- When doing this, look through the mounting hole of cover (2) and check that the strainer guide pin is fitted into the guide hole.
9. Close the cover on the right side of the operator's compartment.

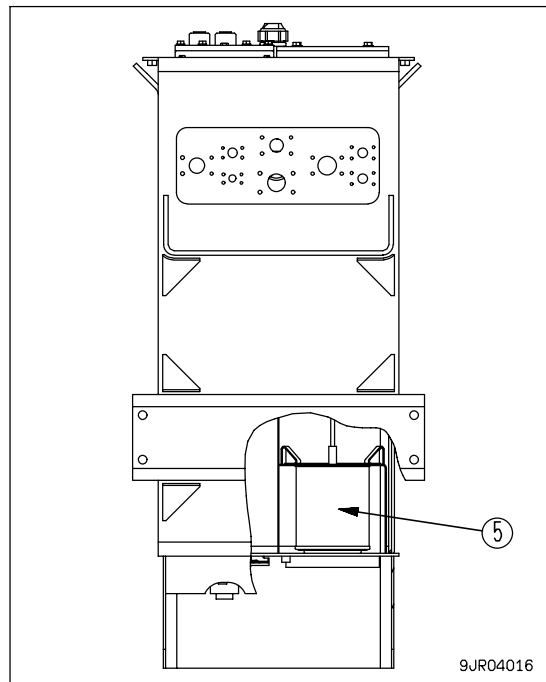
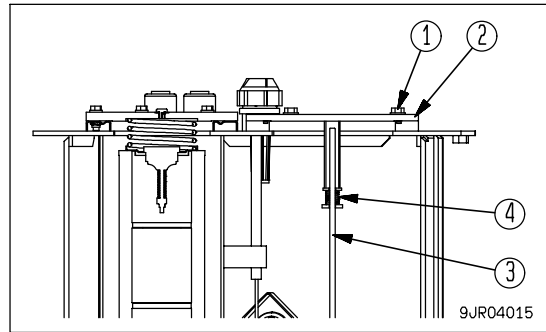

EVERY 8000 HOURS SERVICE

Maintenance for every 50, 100, 250, 500, 1000, 2000 and 4000 hours service should be carried out at the same time.

REPLACE ENGINE HIGH-PRESSURE PIPING CLAMPS

Contact your Komatsu distributor to have the engine high-pressure clamps replaced.

REPLACE FUEL SPRAY PREVENTION CAP

Contact your Komatsu distributor to have the fuel spray prevention cap replaced.

OVERHAUL STARTING MOTOR AND ALTERNATOR

Ask your Komatsu distributor to carry out this work.

RIGHT SWITCH PANEL, CONTROL LEVER SWITCH

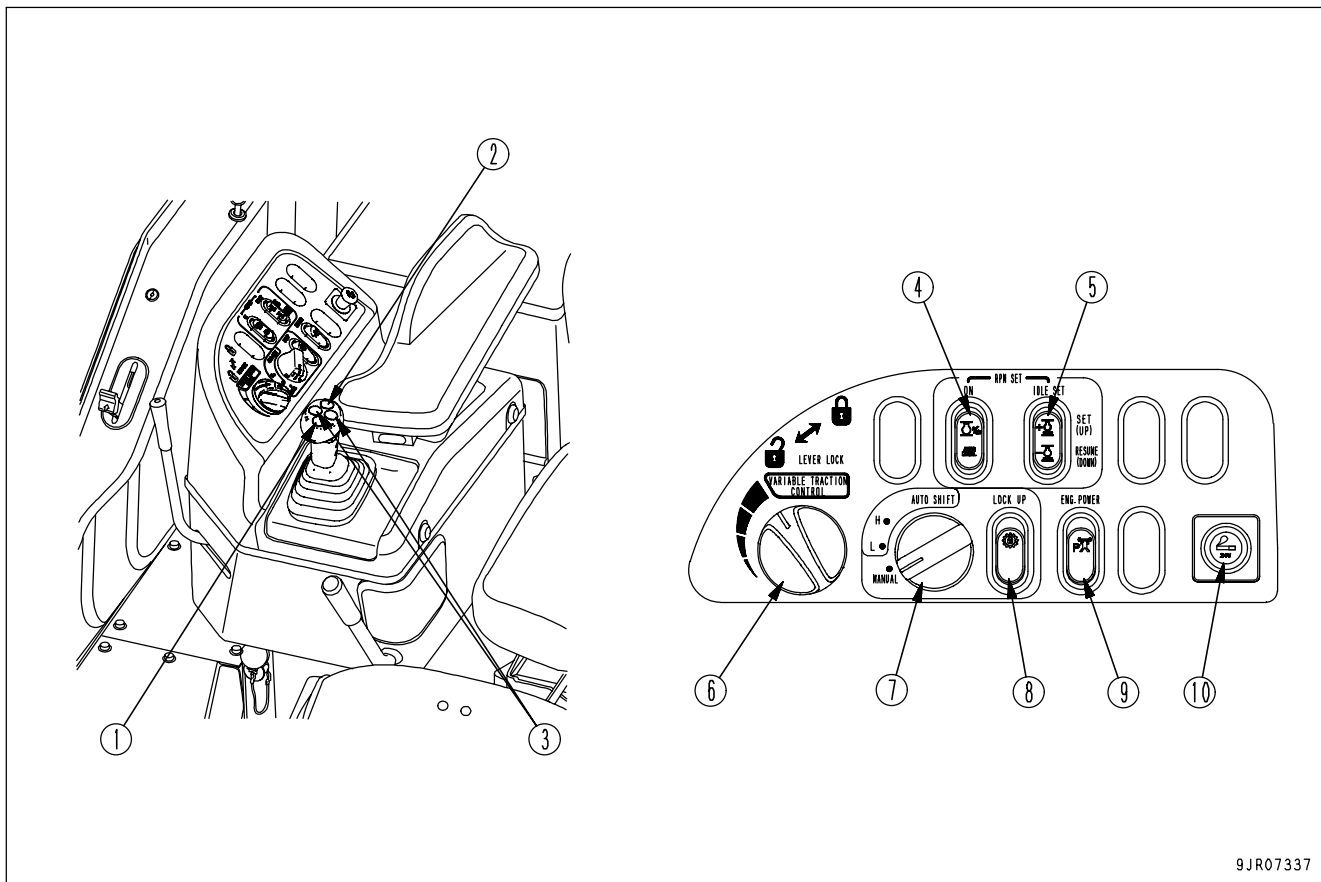

9JR07337

- (1) Kickdown switch
- (2) Hold switch
- (3) Pitch control selector switch
- (4) RPM set ON-OFF switch
- (5) RPM set idling up-down selector switch
- (6) Driving force control dial
- (7) Transmission auto shift/manual shift selector switch
- (8) Torque converter lock-up switch
- (9) Engine power mode selector switch
- (10) Cigarette lighter

For details of switches (1) - (10), see "SWITCHES (PAGE 3-45)" in the OPERATION section.

TURNING

**WARNING**

- Operating the steering wheel suddenly at high speed or operating the steering wheel on steep slopes is dangerous. Do not operate the steering wheel in such situations.
- If the engine stops when the machine is traveling, the emergency steering is actuated. Note that this system is only for steering in emergencies, so never stop the engine.

It is particularly dangerous if the engine stops when the machine is traveling on slopes, so never let the engine stop when traveling on slopes.

If the engine stops, stop the machine immediately at a safe place.

When traveling, use steering wheel (1) to turn the machine.

With this machine, the front frame is joined to the rear frame at the center of the machine by the center pin. The front and rear frames bend at this point, and the rear wheels follow in the same track as the front wheels when turning.

Turn the steering wheel lightly to follow the machine as it turns.

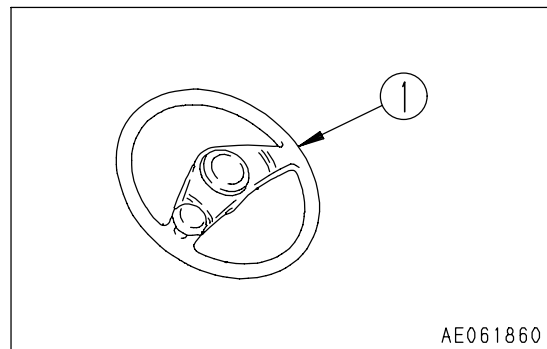
**NOTICE**

Do not attempt to turn the steering wheel any further in an effort to make a sharp turn, when it reaches its stroke end.

Check that steering wheel play (a) is somewhere between 50 to 100mm (2.0 to 3.9 in) and that steering normally functions. If any abnormality is noticed, call your Komatsu distributor for inspection and repair.

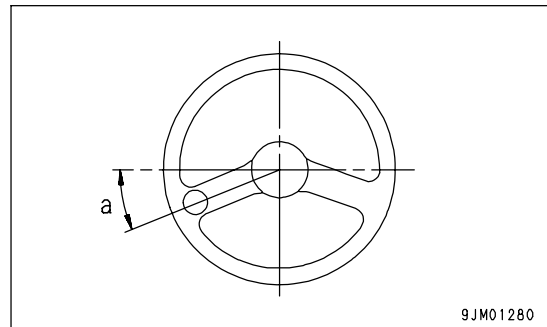

CIRCUIT DIAGRAM FOR EXTERNAL POWER SOURCE TYPE ELECTRIC HEATER

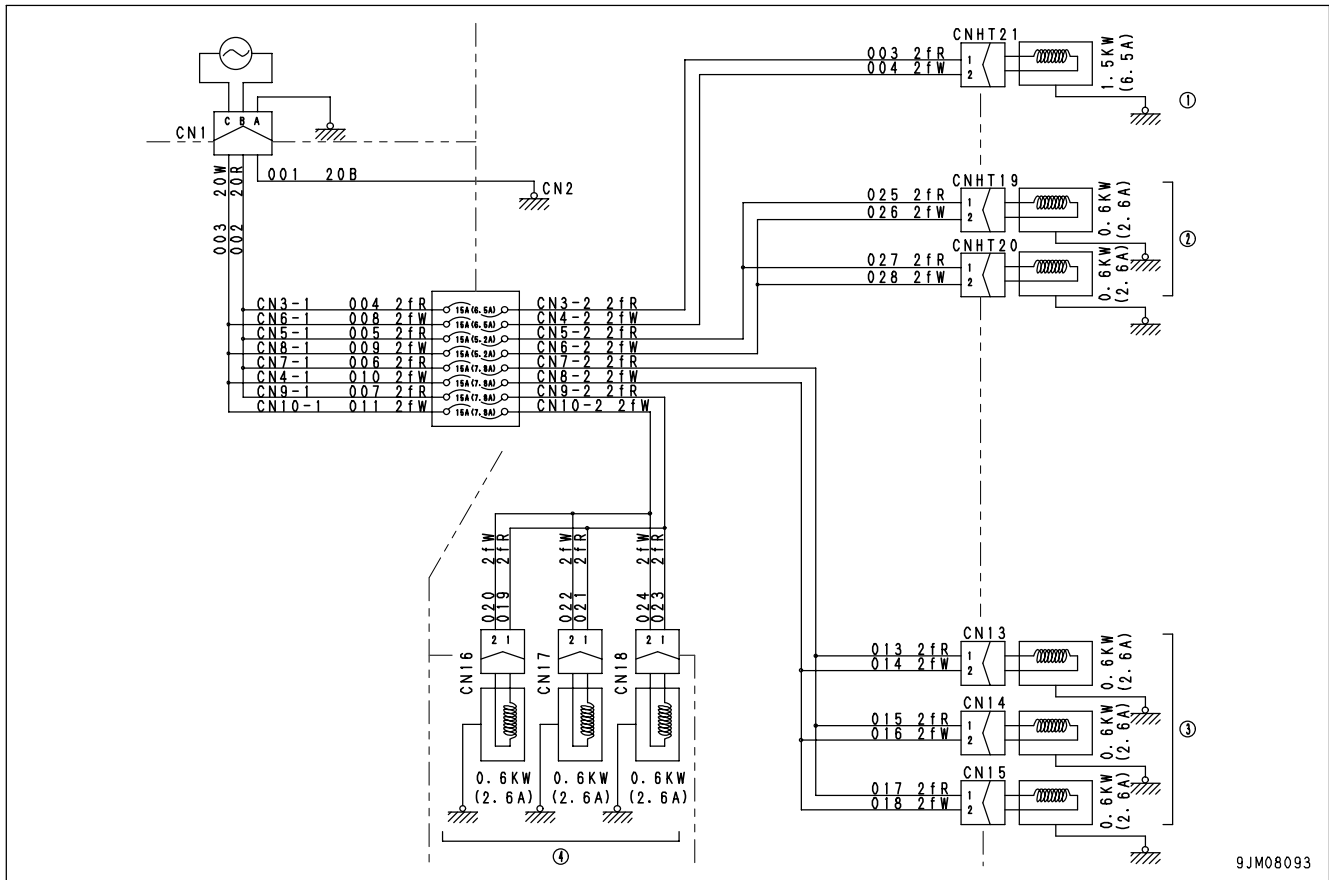

9JM08093

- (1) Cylinder block heater
- (2) Engine oil pan heater

- (3) Hydraulic tank heater
- (4) Transmission oil pan heater

CLICK HERE TO **DOWNLOAD** THE COMPLETE MANUAL

- Thank you very much for reading the preview of the manual.
- You can download the complete manual from: www.heydownloads.com by clicking the link below



- Please note: If there is no response to CLICKING the link, please download this PDF first and then click on it.

CLICK HERE TO **DOWNLOAD** THE COMPLETE MANUAL