

Operation & Maintenance Manual

WHEEL LOADER

WA800-3E0

WA900-3E0

SERIAL NUMBERS

WA800-70001

WA900-60001

and up

WARNING

Unsafe use of this machine may cause serious injury or death. Operators and maintenance personnel must read this manual before operating or maintaining this machine. This manual should be kept near the machine for reference and periodically reviewed by all personnel who will come into contact with it.

NOTICE

Komatsu has Operation & Maintenance Manuals written in some other languages. If a foreign language manual is necessary, contact your local distributor for availability.

KOMATSU

CLICK HERE TO **DOWNLOAD** THE COMPLETE MANUAL

- Thank you very much for reading the preview of the manual.
- You can download the complete manual from: www.heydownloads.com by clicking the link below



- Please note: If there is no response to CLICKING the link, please download this PDF first and then click on it.

CLICK HERE TO **DOWNLOAD** THE COMPLETE MANUAL

POSITION OF SERVICE METER

On the lower right of maintenance monitor.

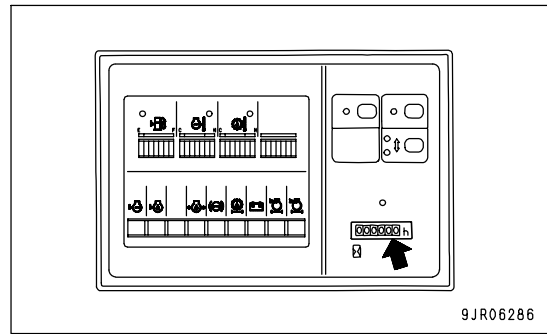

TABLE TO ENTER SERIAL NO. AND DISTRIBUTOR

Machine serial No.	
Engine serial No.	
Product identification number (PIN)	
Distributor name	
Address	-----

Service Personnel	-----
Phone/Fax	-----

NO PEOPLE ON ATTACHMENTS

Never let anyone ride on the work equipment or other attachments. There is a hazard of falling and suffering serious personal injury or death.

PRECAUTIONS WHEN STANDING UP FROM OPERATOR'S SEAT

Before standing up from the operator's seat, such as when adjusting the position of the seat, always lower the work equipment completely to the ground, set work equipment lock lever (1) and steering lock lever (2) to the lock position (L), turn parking brake switch (3) ON, and stop the engine.

If the control levers are touched by mistake, the machine may suddenly move and cause serious personal injury or death.

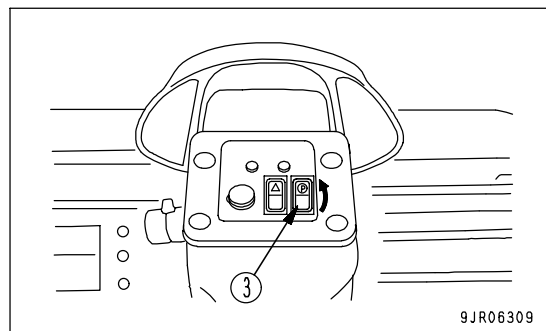
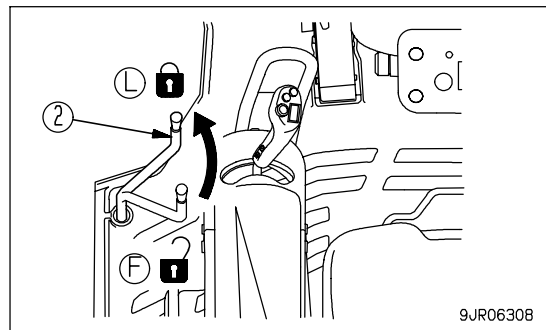
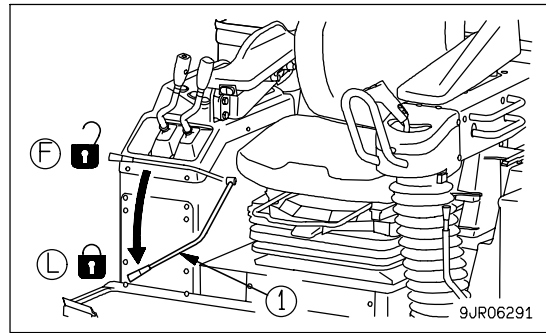
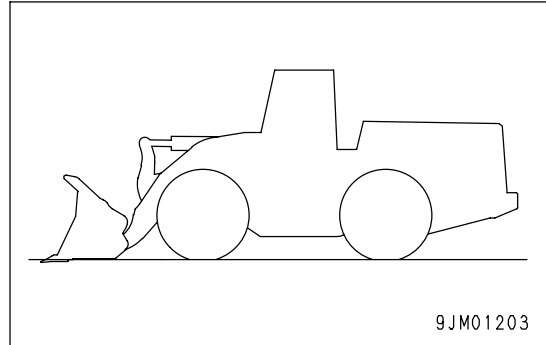

OPERATION

CHECKS BEFORE OPERATION

If the checks before starting are not carried out properly, the machine will be unable to display its full performance, and there is also danger that it may lead to serious personal injury or death.

When carrying out the checks, move the machine to a wide area where there are no obstructions, and pay careful attention to the surrounding area. Do not allow anyone near the machine.

- Always wear the seatbelt. There is danger that you may be thrown out of the operator's seat and suffer serious injury when the brakes are applied suddenly.
- Check the operation of travel, steering and brake systems, and work equipment control system.
- Check for any problem in the sound of the machine, vibration, heat, smell, or gauges; check also that there is no leakage of oil or fuel.
- If any problem is found, carry out repairs immediately.

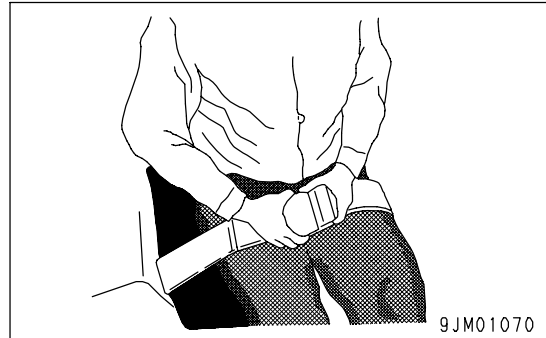

- Before driving the machine or starting operations, check that frame lock bar (1) is securely fixed at the FREE position.

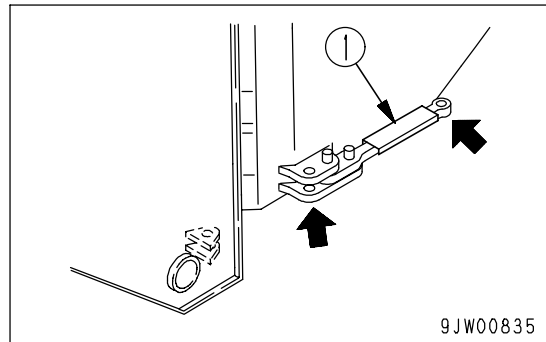

PRECAUTIONS WHEN TRAVELING IN FORWARD OR REVERSE

- Lock the cab door and windows securely, both when they are open and when they are closed.
- Do not allow anyone apart from the operator to ride on the machine.
- If there are any persons in the area around the machine, there is danger that they may be hit or caught by the machine, and this may lead to serious personal injury or death. Always observe the following before traveling.
 - Always operate the machine only when seated.
 - Before moving off, check again that there is no person or obstruction in the surrounding area.
 - Before moving, sound the horn to warn people in the surrounding area.
 - Check that the backup alarm (alarm buzzer when machine travels in reverse) works properly.
 - If there is an area to the rear of the machine which cannot be seen, position a signalman.

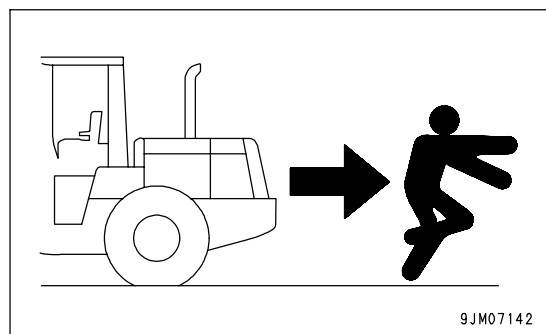

Always be sure to carry out the above precautions even when the machine is equipped with mirrors.

STOP ENGINE BEFORE CARRYING OUT INSPECTION AND MAINTENANCE

- Lower the work equipment completely to the ground and stop the engine before performing any inspection and maintenance.

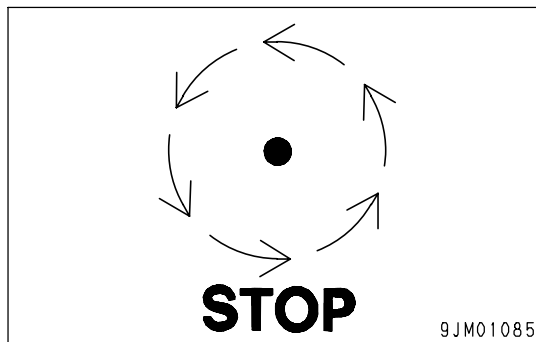

- After stopping the engine, turn the starting switch to the ON position, operate work equipment control lever (1) fully in the RAISE and LOWER directions 2 - 3 times to release the remaining pressure in the hydraulic circuit, then set work equipment lock lever (2) and steering lock lever (3) to LOCK position (L).

After releasing the remaining pressure in the hydraulic circuit, turn the starting switch to the OFF position.

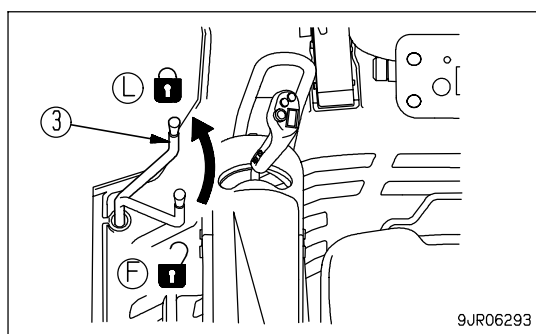
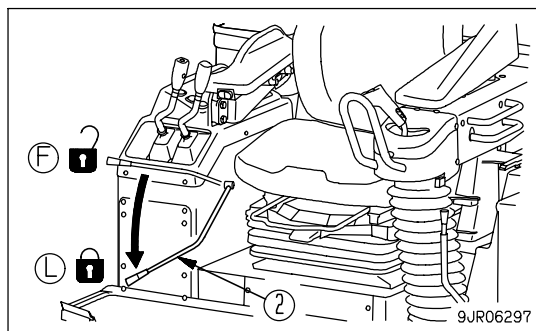
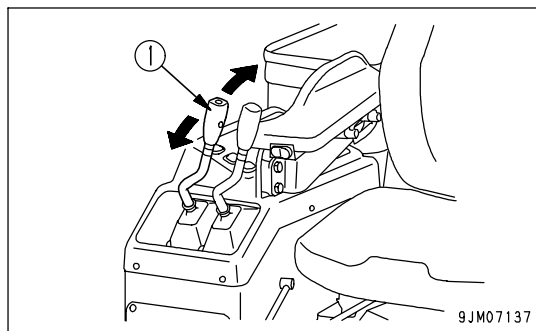

TIRES

HANDLING TIRES

If tires or rims are handled mistakenly, there is danger that the tire may explode or be damaged, or that the rim may fly off and cause serious personal injury or death.

To maintain safety, always do as follows.

- Maintenance, disassembly, repair, and assembly of the tires and rims requires special equipment and special technology, so always ask your Komatsu distributor to carry out these operations.
- Always use the tires specified by Komatsu and maintain the specified inflation pressure.

Suitable tire inflation pressure: see "HANDLING THE TIRES (PAGE 3-143)"

- When pumping up the tires, check that no other person is standing near the tire, and install an air chuck with a clip that can be secured to the air valve.

To prevent the tire inflation pressure from becoming too high, measure the pressure from time to time with an air gauge while pumping up the tire.

- If the tire pressure goes down abnormally or the rim parts do not fit the tire, there is a problem with the tire or rim parts. Always contact your Komatsu distributor for repairs.
- If the rim parts are not fitted properly when the tire is being pumped up, there is danger that the rim parts may fly off, so set up a protective fence around the tire, and do not stand directly in front of the rim. Stand beside the tread when pumping up the tire.
- Do not adjust the tire inflation pressure immediately after traveling at high speed or carrying out operations under heavy load.
- Never carry out welding or light a fire near the tire.
- Always release all pressure from a single tire or from both tires of a dual assembly prior to removing any rim components.
- Before removing the tire from the machine for repairs, remove the valve partially to release the air from the tire, then remove the tire.

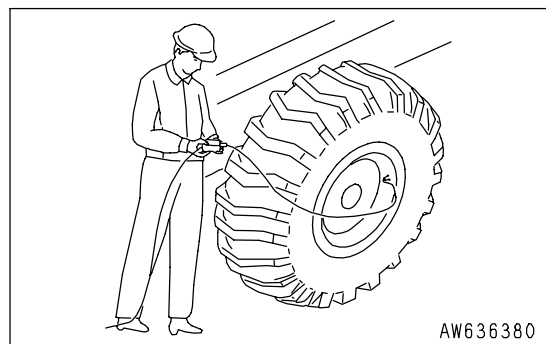
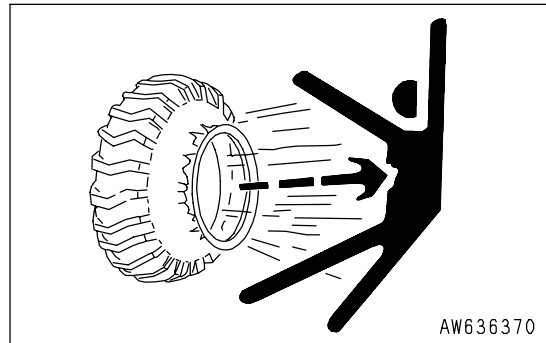

The machine monitor system consists of the main monitor (in front of the operator's seat) maintenance monitor (on the right side of the operator's seat), 1st, 2nd, 3rd speed indicator lamps, engine service monitor, engine warning lamp, and prelube indicator lamp.

These are divided according to function into warning display portions (B, E, H), meter display portions (A, C, D, F, G, J, K), and character display portion (L).



CAUTION

These monitors do not guarantee the condition of the machine.

Do not simply rely on the monitor when carrying out checks before starting (daily inspection). Always get off the machine and check each item directly.

WARNING DISPLAYS

Warning display portions (B, E, H) consist of the following.

(For details, see "WARNING DISPLAY (PAGE 3-10)".)

- Central check lamp (CHECK)
- Central caution lamp (CAUTION)
- Warning pilot lamp
 - Engine water level
 - Engine oil level
 - Brake oil pressure
 - Engine oil pressure
 - Battery charge
 - Air cleaner clogging
 - Transimission oil filter
 - Emergency steering
 - Engine warning lamp

METER DISPLAY PORTION

Meter display portions (A, C, D, F, G, J, K) consist of the following.

(For details, see "METER DISPLAY PORTION (PAGE 3-16)".)

- | | |
|---|---|
| <ul style="list-style-type: none"> • Meter <ul style="list-style-type: none"> • Speedometer • Fuel gauge • Engine water temperature gauge • Torque converter oil temperature gauge • Service meter • Transmission shift indicator | <ul style="list-style-type: none"> • Pilot lamp <ul style="list-style-type: none"> • Turn signal lamp • Preheating • Front and side working lamps • Rear working lamp • Transmission cut-off • Parking brake • Transimssion auto shift/manual selector • 1st, 2nd, 3rd speed indicators • Prelube indicator • Remote positioner RAISE stop • Remote positioner LOWER stop • Remote positioner RAISE set • Remote positioner LOWER set • Auto greasing • Engine low idling selector |
|---|---|

TRANSMISSION CUT-OFF PILOT LAMP

This lamp (5) lights up when the transmission cut-off switch is turned to ON.

If the monitor lamp is ON and the left brake pedal is depressed, the transmission will be returned to neutral.

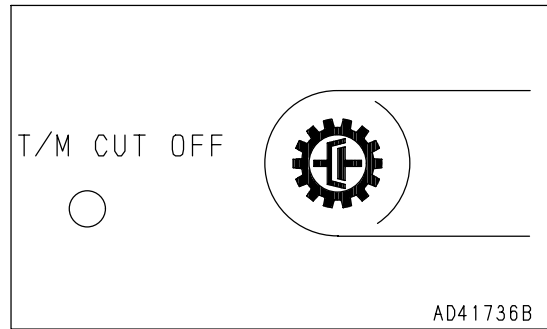
**TURN SIGNAL PILOT LAMP**

When the turn signal lamp flashes, this lamp (6) also flashes.

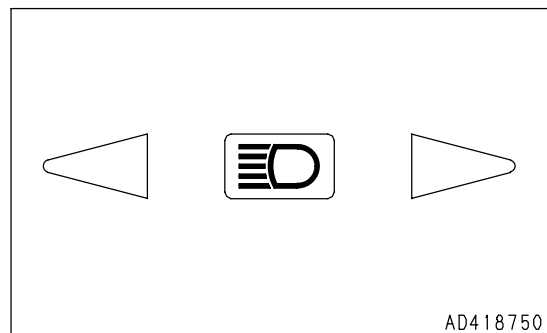
**TRANSMISSION AUTO SHIFT/MANUAL SELECTOR PILOT LAMP**

This lamp (7) lights up when the transmission auto shift/manual selector switch is operated and the transmission shift is changed to manual mode.

When the lamp is lighted up, the speed range can be changed by operating the shift up/shift down switch.

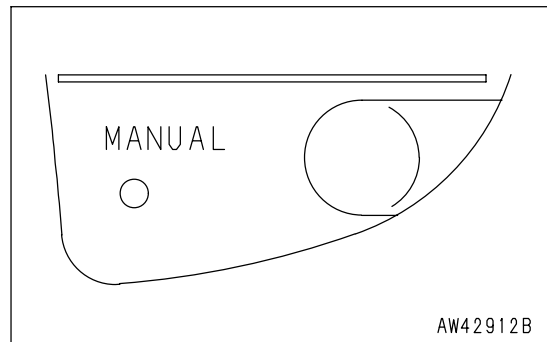
**1ST, 2ND, 3RD SPEED INDICATOR LAMP**

This lamp (8) lights up during auto shift and displays the maximum speed range for automatic shifting of the transmission. The maximum speed range can be selected with the shift up switch and the shift down switch.

- 1 lights up: Transmission speed range is fixed at 1st
- 2 lights up: Transmission speed range is fixed at 2nd
- 3 lights up: Transmission speed range is shifted automatically between 2nd and 3rd

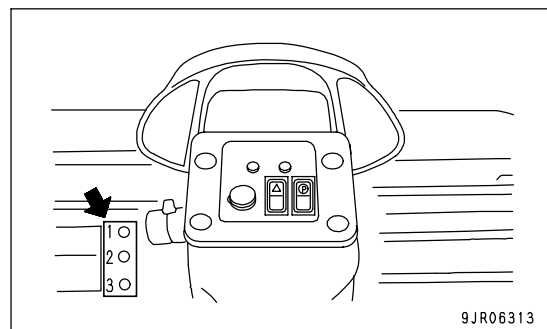

TRANSMISSION AUTO SHIFT/MANUAL SELECTOR SWITCH

Press push button switch (6) to turn the switch ON or OFF.

When the switch is pressed once, the pilot lamp lights up and the lamp is turned ON; when the switch is pressed again, the pilot lamp goes out and the lamp is turned OFF.

Normally, keep the switch at the OFF position.

OFF: System is set to auto shift

The transmission shifts automatically according to the travel speed. The maximum speed range selected for automatic shifting is displayed by the 1st, 2nd, 3rd speed indicator lamp at the bottom of the main monitor.

ON: System is set to manual shift

Use the shift up and shift down switches to select the speed range when traveling.

The 1st, 2nd, 3rd speed indicator lamp go out.

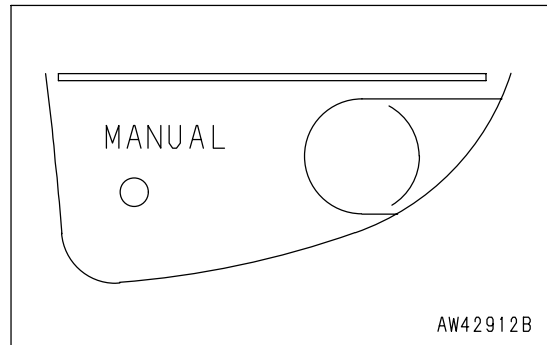

When the switch is set to the ON position, the transmission auto shift/manual selector pilot lamp lights up.

REMARK

- The speed range after turning the starting switch to the ON position is the final speed range selected by the previous operation.
- If the system is shifted from auto shift to manual shift, or from manual shift to auto shift when the machine is stopped, the speed range is automatically set to 2nd.

ACTIVE WORKING SWITCH

Use this switch (7) to switch the condition of the machine to match the purpose of operation.

Powerful Loading position: The drive force when digging becomes larger. When the drive force is large, the work equipment speed is slow, so this is suitable only for loading rocks.

Normal Loading position: The work equipment speed is fast, so this is suitable only for loading products.

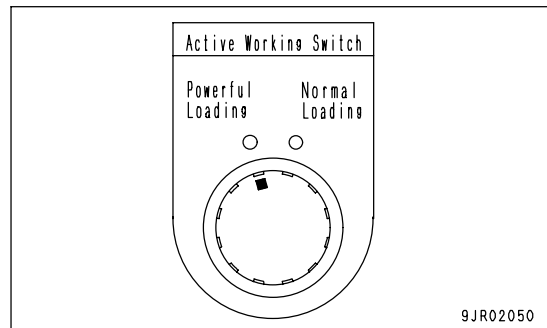

CONTROL LEVERS, PEDALS

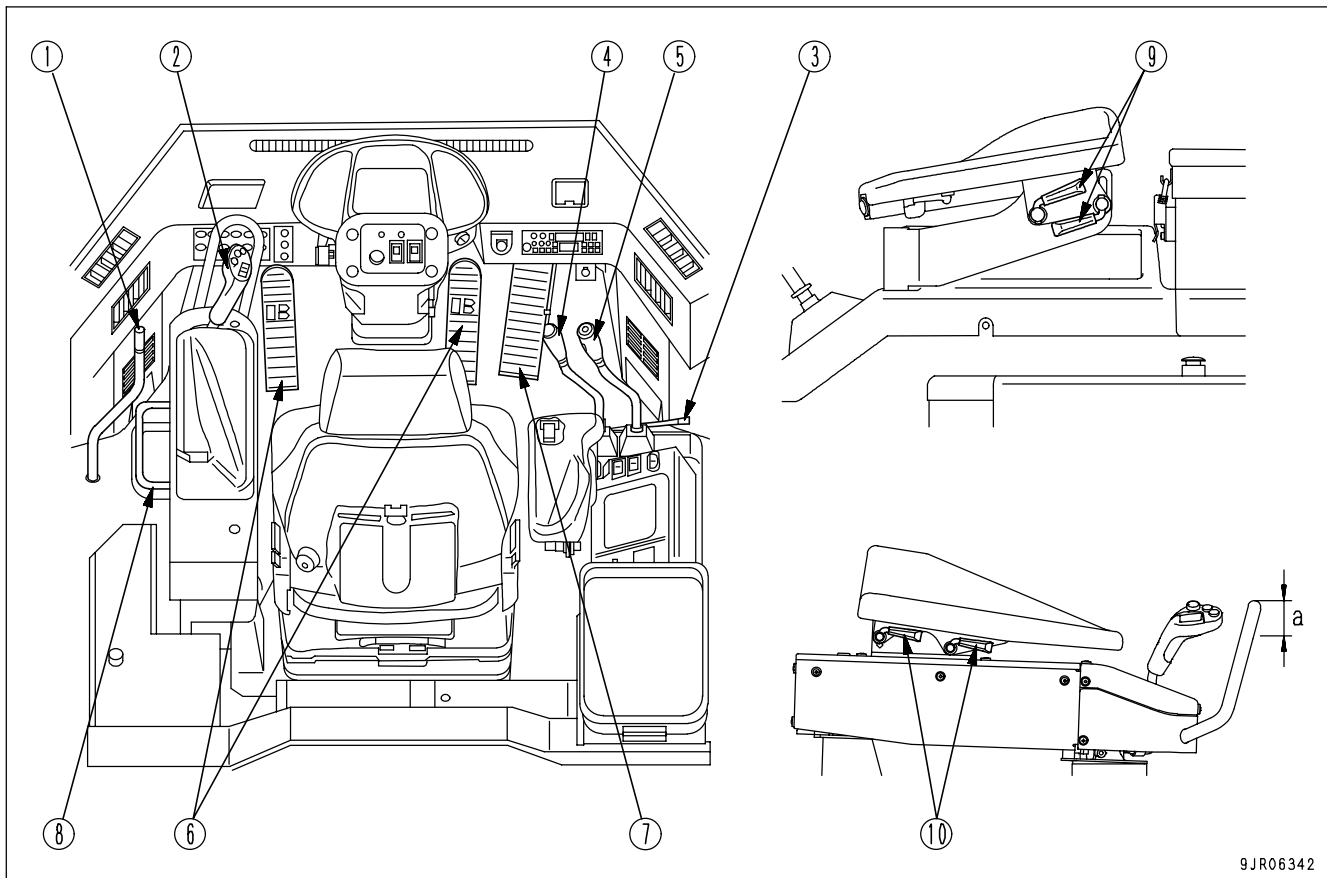

9JR06342

- | | |
|-------------------------------|---|
| (1) Steering lock lever | (6) Brake pedal |
| (2) AJSS lever | (7) Accelerator pedal |
| (3) Work equipment lock lever | (8) AJSS lever front-rear adjustment knob |
| (4) Bucket control lever | (9) Right armrest adjustment lever |
| (5) Lift arm control lever | (10) Left armrest adjustment lever |

CAB DOOR OPEN LOCK

This can be used to hold the door open.

Open the door so that tip (2) of the lever is aligned with groove (1) of the lock, then pull down knob (3) as shown in the diagram.

When using the door-open lock, be sure to apply the lock securely. When releasing the lock and closing the door, push up knob (3) and insert pin (4) securely into the groove.

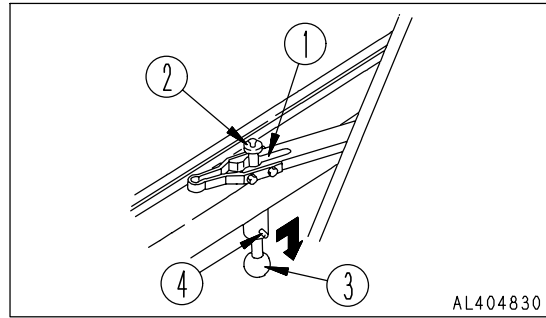

HANDLING CAB WIPER

PREVENTING DAMAGE TO WIPER ARM BRACKET

NOTICE

When angling the wiper arm to the front, check that the wiper blade is hanging free.

When angling the wiper arm to the front, such as when wiping the glass clean, if the wiper arm is angled with the wiper blade locked to the arm (the bottom of the blade is caught on the arm), abnormal force is brought to bear on the mounting bracket and the bracket may break.

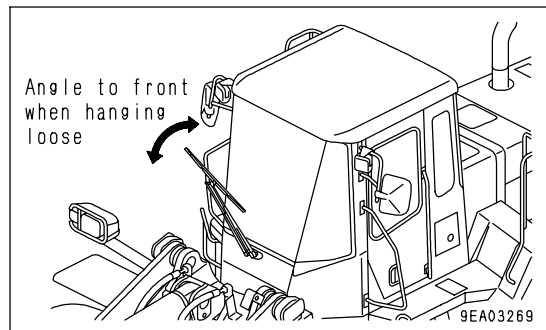

REPLACING CAB WIPER

! WARNING

Do not attempt to replace the cab wiper, standing on the front frame. It is very dangerous to climb on the front frame.

When replacing the cab wiper, articulate the machine 40° to the right, place stand (1) in position, then stand on it and replace the wiper. Be careful not to fall off the stand.

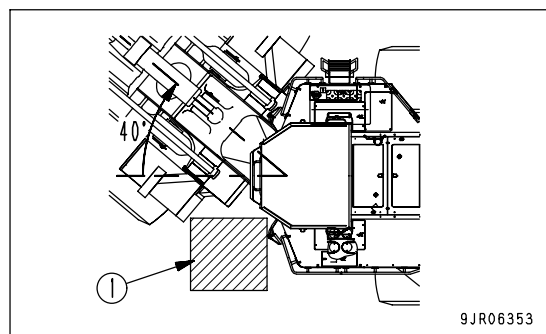

TAPE EJECT BUTTON

This button (7) is used to stop the tape and to eject the cassette. When this button is pressed, the tape is ejected and the radio plays.

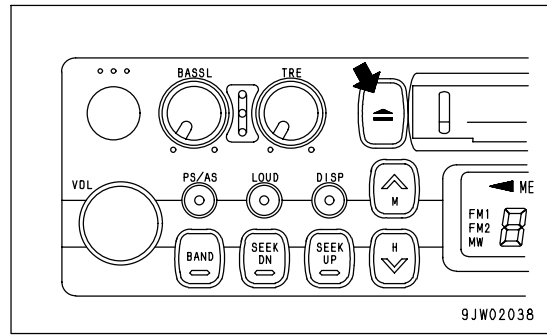

CASSETTE DOOR

Set the cassette with the exposed portion of the tape on the right side and insert it through the cassette door (8).

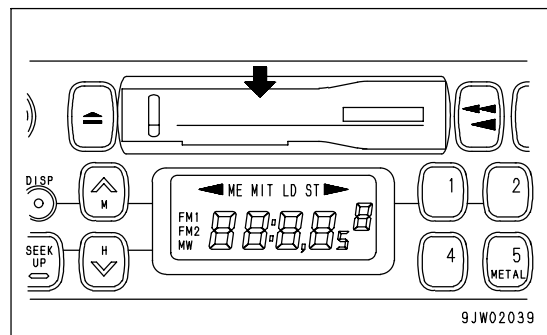

FAST-FORWARD, REWIND BUTTONS

These buttons (9) are used to fast-forward or rewind the tape.

- Fast-forward/rewind

If you press the button pointing in the same direction as the lighted arrow indicating the direction of play, the tape will be fast-forwarded; if you press the button pointing in the opposite direction, the tape will rewind.

To stop the tape, lightly press the button that is not locked. The fast-forward or rewind operation will be canceled.

If the fast-forward and rewind buttons are pressed at the same time, the tape will change sides.

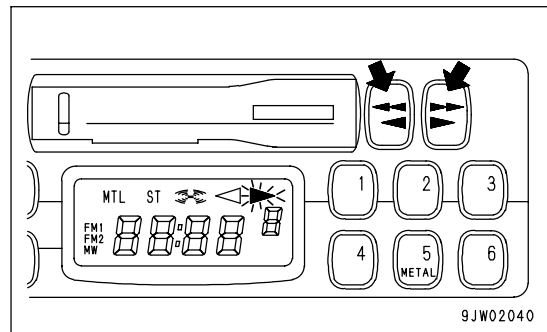

PRESET BUTTONS

These buttons (10) are used to call up the broadcast station frequencies preset in memory for each of buttons No. 1 to No. 6. It is possible to preset 18 stations (FM: 12; AM: 6) with these buttons.

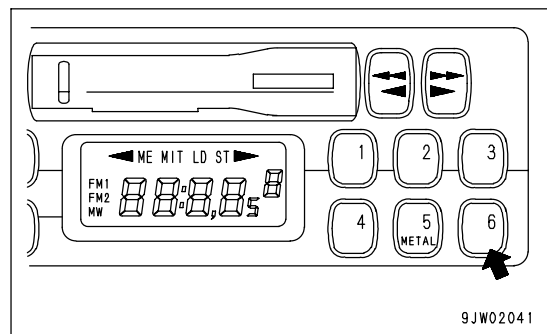

USE AIR CONDITIONER WITH CARE

NOTICE

- When running the air conditioner, always start with the engine running at low speed. Never start the air conditioner when the engine is running at high speed. It will cause failure of the air conditioner.
- If water gets into the control panel or sunlight sensor, it may lead to unexpected failure, be careful not to let water get on these parts. In addition, never bring any flame near these parts.

VENTILATION

- If you smoke when the air conditioner is on, the smoke may start to hurt your eyes, so open the window and turn the lever to FRESH for a while to remove the smoke while continuing the cooling.
- When using the air conditioner for a long time, carry out ventilation and cooling once every hour.

TEMPERATURE CONTROL

When the cooler is on, set the temperature so that it feels slightly cool when entering the cab (5 or 6 °C (9 or 10.8 °F) lower than the outside temperature). This temperature difference is considered to be the most suitable for your health, so always be careful to adjust the temperature properly.

AIR CONDITIONER MAINTENANCE

When carrying out inspection and maintenance of a machine equipped with an air conditioner, carry out the inspection and maintenance in accordance with the maintenance schedule chart. For details, see "MAINTENANCE SCHEDULE CHART (PAGE 4-19)".

COOL BOX

When the cooling is being used, this can be used for keeping drinks and other things cool.

When the heating is being used, it can be used to keep things warm.

When using the box, open the vent grill.

When not using the box, close the grill.

Do not use the cool box for things which smell or leak water or break easily.

Do not use it as a holder for tools or other small objects.

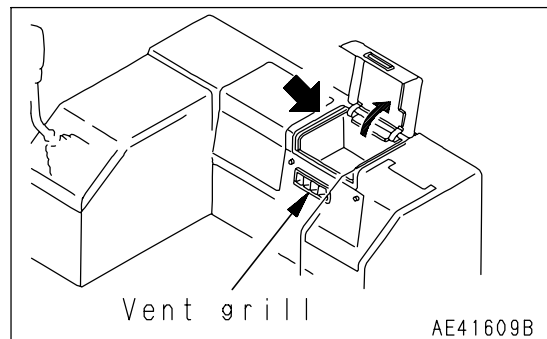

CHECK OIL LEVEL IN ENGINE OIL PAN, ADD OIL

**WARNING**

Parts and oil are at high temperature immediately after the engine is stopped and may cause serious burns. Wait for the oil temperature to go down before performing this operation.

1. Stop the engine and wait for the temperature at all parts to go down.

REMARK

- When checking the oil level after the engine has been operated, wait for at least 15 minutes after stopping the engine before checking.
 - o Checking the oil level with the engine idling may be allowed, if the following precautions are thoroughly satisfied:
 - o Check that the engine water temperature gauge shows green range.
 - o Use the side of the dipstick marked "ENGINE IDLING".
 - o Remove the oil filler cap.
- If the machine is at an angle, make it horizontal before checking.

2. Open the engine side cover at the rear left of the machine.
3. Take out the dipstick (G) and wipe off the oil with cloth.
4. Fully insert dipstick (G) into filler pipe (F), then remove it.
5. The oil level should be between the H and L marks on dipstick (G).

If the oil level is below the L mark, add oil through oil filler (F). The dipstick has level markings on both sides. One side gives the levels for measuring when the engine is stopped (ENGINE STOPPED) and the other side gives the levels for when the engine is idling (ENGINE IDLING).

When measuring the oil level, measure with the engine stopped and use the side of the dipstick marked "ENGINE STOPPED".

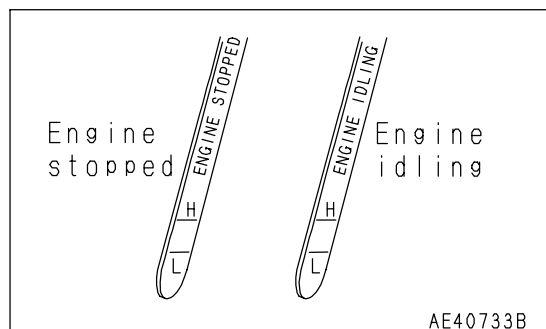
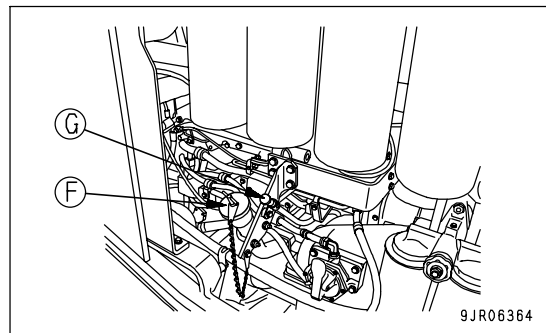

6. If the oil is above the H line, install a hose to the oil drain port of drain plug (P), drain the excess oil, then check the oil level again.
7. If the oil level is correct, tighten oil filler cap (F) securely, then remove the hose and close the engine side cover.

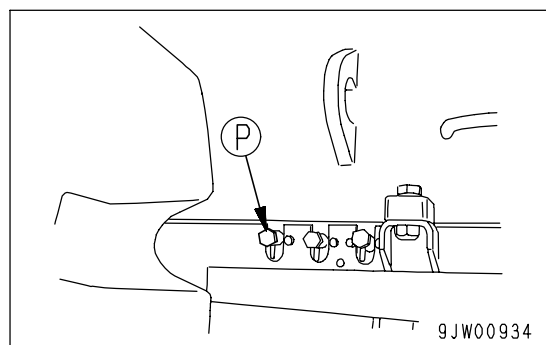

3. Lower the bucket to the ground and check that work equipment lock lever (5) of work equipment control lever (4) is at LOCK position (L). If it is not at LOCK position (L), move it from FREE position (F) to LOCK position (L).

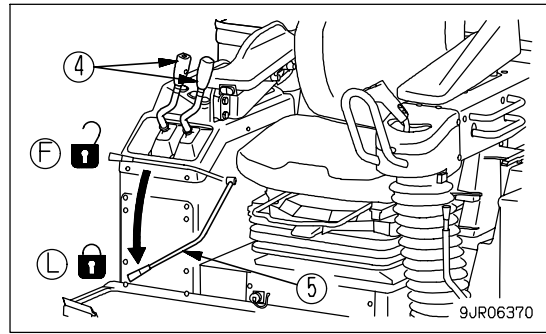

4. Insert the key in starting switch (6), turn the key to the ON position, and check that the machine monitor system works. When the starting switch is turned to the ON position before starting the engine, all monitor lamps, gauges, and central warning lamps will light up for approx. 3 seconds, the central warning lamp will light up and the alarm buzzer will sound for approx. 1 second. When this happens, 88 is displayed on the speedometer, and 8 is displayed on the transmission shift indicator. If the monitor lamps do not light up, there is probably a failure or disconnection, so please contact your Komatsu distributor for inspection.

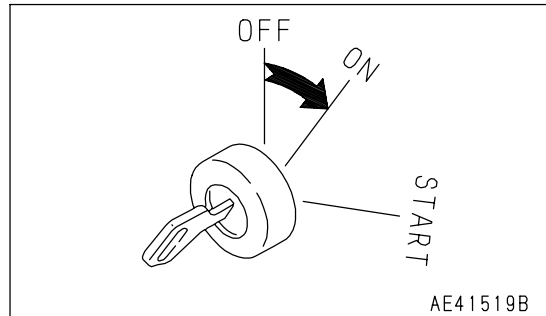

7. Release right brake pedal (8), then depress accelerator pedal (13) to move the machine off.

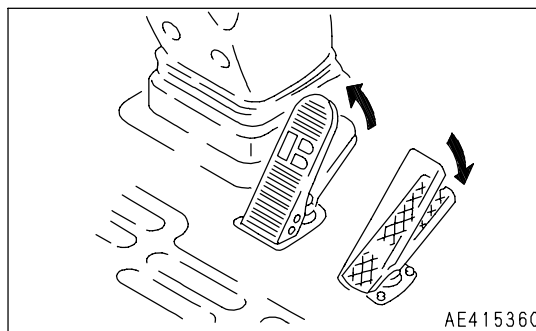
**REMARK**

When moving the machine off on a hill, turn the transmission cut-off switch (14) OFF, depress left brake pedal (15), set directional selector switch (12) to F, then depress the accelerator pedal (3) and gradually release left brake pedal (15) to let the machine move off. This makes it possible to prevent the machine from rolling back.

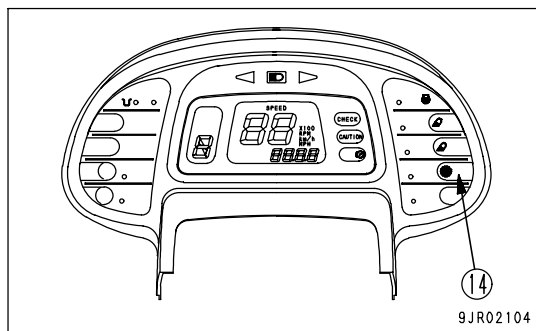

OPERATION OF WORK EQUIPMENT

WARNING

- When standing up from the operator's seat, always set the work equipment lock lever securely to the LOCK position. If the work equipment lock lever is not locked, and work equipment control lever (A) is touched by mistake, this may lead to serious personal injury.
- If the work equipment lock lever is not set securely to LOCK position (L), the work equipment may move and cause serious personal injury. Check that the work equipment lock lever is at the position shown in the diagram.
- When pulling the work equipment lock lever up or pushing it down, be careful not to touch work equipment control lever (1).

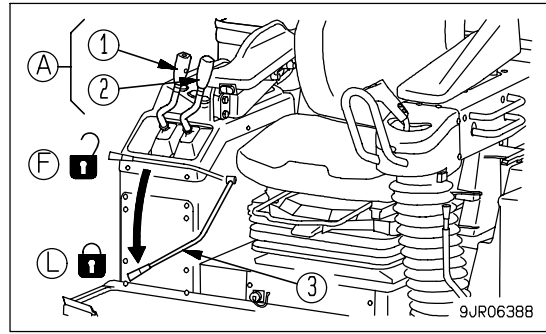

Work equipment control lock lever (3) is the locking device for work equipment control lever (A). Lower the work equipment lock lever to set it to the LOCK position.

Lift arm control lever (1) and bucket control lever (2) can be used to operate the lift arm and bucket as follows.

LIFT ARM CONTROL LEVER

Set the work equipment lock lever to the FREE position before operating the control lever.

Position (A): RAISE

Position (B): HOLD

The lift arm is stopped and held in position.

Position (C): LOWER

Position (D): FLOAT

The lift arm moves freely under external force.

When the lift arm control lever is pulled further from the raise position, the lever is stopped in this position until the lift arm reaches the preset kick-out position, and the lever is return to the hold position.

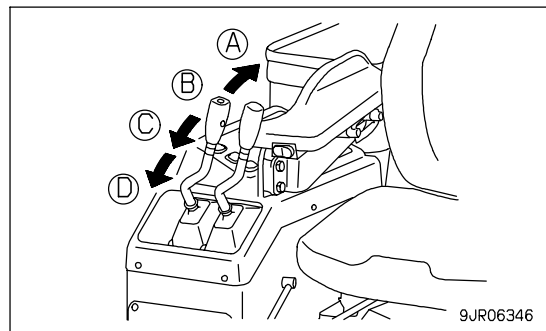

NOTICE

Do not use the FLOAT position when lowering the bucket. Use the FLOAT position when leveling, see "LEVELING OPERATIONS (PAGE 3-116)".

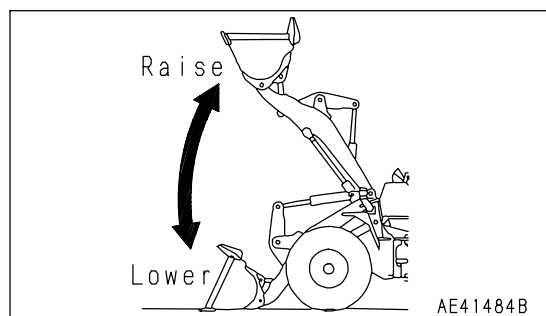

CLICK HERE TO **DOWNLOAD** THE COMPLETE MANUAL

- Thank you very much for reading the preview of the manual.
- You can download the complete manual from: www.heydownloads.com by clicking the link below



- Please note: If there is no response to CLICKING the link, please download this PDF first and then click on it.

CLICK HERE TO **DOWNLOAD** THE COMPLETE MANUAL

V-SHAPE LOADING

Position the dump truck so that the direction of approach of the wheel loader is approx. 60 degrees from the direction of approach to the stockpile. After loading the bucket, drive the wheel loader in reverse, then turn it to face the dump truck and travel forward to load the dump truck.

The smaller the turning angle of the wheel loader is, the more efficient the operation becomes.

When loading a full bucket and raising it to the maximum height, first shake the bucket to stabilize the load before raising the bucket. This will prevent the load from spilling to the rear.

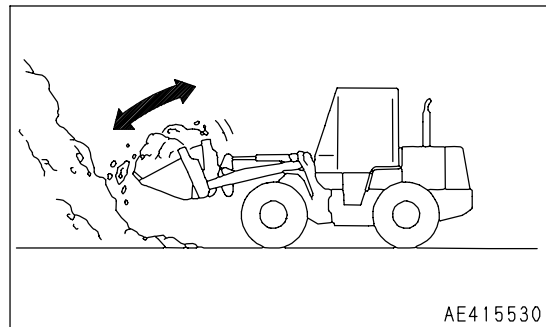
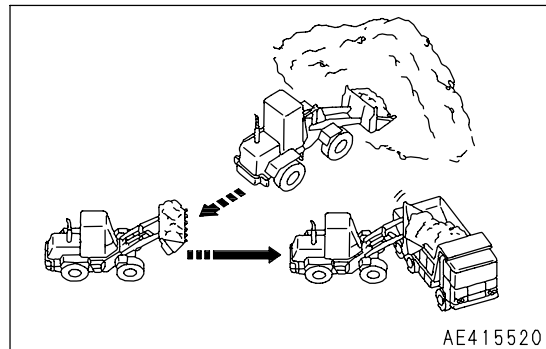
**PRECAUTIONS WHEN PILING UP LOADS**

When forming products into a pile, be careful not to let the rear counterweight come into contact with the ground. Do not set the bucket to the DUMP position when piling-up loads.

REMARK

As far as possible, do not use the transmission cut-off function during scraping-up operation. This will prevent the machine from rolling back.

TRAVELING IN REVERSE AFTER EXCAVATING

NOTICE

- Do not operate the steering immediately after starting to travel in reverse. The bucket is still thrust into the rocks, so if the steering is operated, excessive force will be brought to bear on the bucket or frame, and there is danger of damage to the frame.
- After shifting the transmission, operate the accelerator pedal slowly. If the accelerator pedal is operated suddenly, the tires will slip and this will cause wear or cutting of the tires.

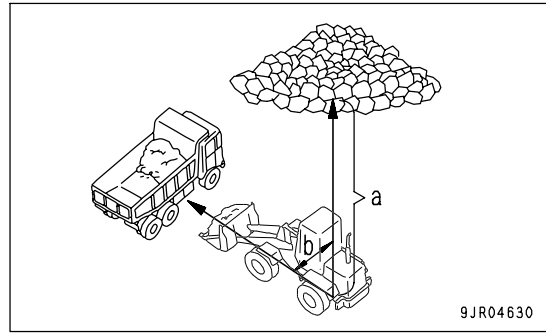

1. After completing the excavation, shift to R2 and travel in reverse without operating the steering.
2. As a guideline, reverse travel distance (a) should be 1.2 -1.5 times the length of the machine. At this distance, the rolling of the tires can prevent wear to the tires.
In addition, keep an angle (b) of 60° at the intersection between the straight line from the dilution and the straight line from the dump truck.

REMARK

Decide the steering procedure to match the stopping point of the dump truck and the condition of the dilution. When doing this, decide the stopping point for the dump truck so that the operating angle for the steering is less than 20°.

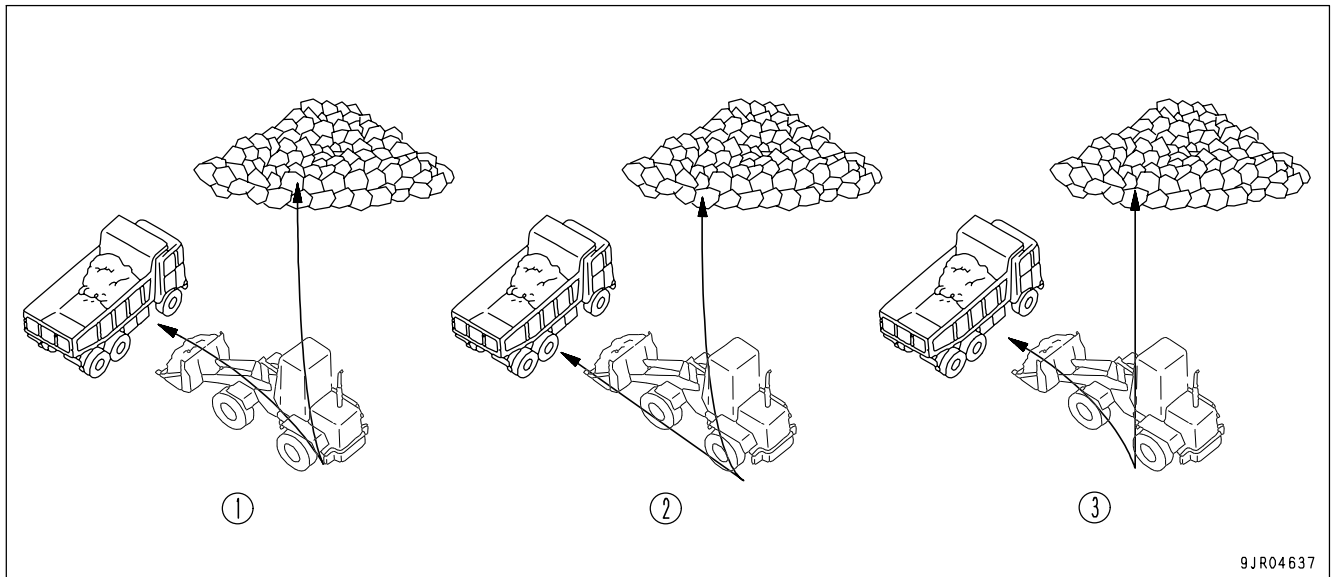

- (1) Gradual steering to left or right
- (2) Gradual steering to dilution
- (3) Direct line to dilution

3. When driving in reverse, do not raise the bucket more than necessary.
Consider the position of the dump truck, the condition of the road surface, the travel speed, and the speed of the work equipment when deciding the height of the bucket. However, do not raise the bucket so that the top of the load is higher than the horizontal line of sight from the operator.

INSTALLING THE BUCKET

Before installing the bucket, remove all grease, mud, or sand and clean the pin, pin hole, and area around the boss. (If there is any rust or dirt on the inside surface of the pin hole, use sandpaper and remove it carefully.)

After cleaning, coat the pin and inside surface of the pin hole with fresh grease.

1. Set cord ring (2) on top of lift arm boss (1) as shown in the diagram.

After completing assembly of the bucket and adjustment with shims in step 8, move the cord ring down to the groove.

2. Coat dust seal lip portion (3) with grease.

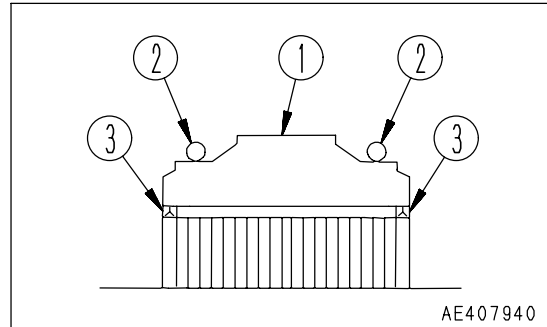

3. Align the left and right bucket pin holes.

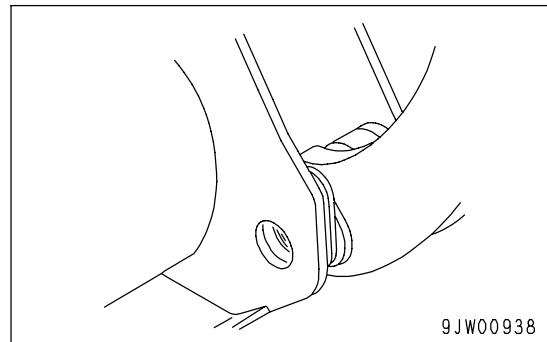

4. Select the number of shims so that clearance A between bucket hinge boss (4) and lift arm boss (1) are less than 1.0 to 1.5 mm (0.04 to 0.06 in).

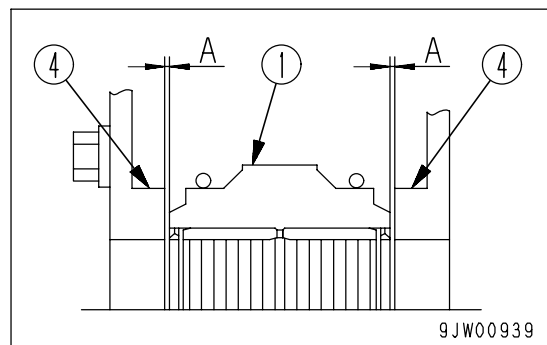

5. Assemble the shims selected in Step 4, align the pin holes, then insert bucket hinge pin (5).

Coat with grease to prevent damage to the dust seal when inserting the bucket hinge pin.

Use a bucket hinge pin that has a grease hole.

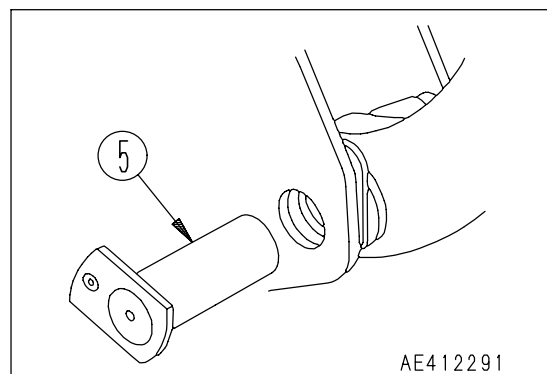

METHOD OF LIFTING MACHINE

When lifting the machine at a port or any other place, always use the following procedure to lift it.



WARNING

- The operator carrying out the lifting operation using a crane must be a properly qualified crane operator.
- Never raise the machine with any worker on it.
- Always make sure that the wire rope is of ample strength for the weight of this machine.
- When lifting, keep the machine horizontal.
- When lifting the machine, always stop the engine, apply the parking brake, and set the safety lock lever to the LOCK position. Lock with the safety bar to prevent the front frame from articulating, and take steps to prevent the machine from moving unexpectedly.
- Never enter the area around or under the machine when it is raised.

Never try to lift the machine in any posture other than the posture given in the procedure below or using lifting equipment other than in the procedure below.

There is a hazard that the machine may lose its balance.

NOTICE

This method of lifting applies to the standard specification machine.

The method of lifting differs according to the attachments and options installed.

For details of the procedure for machines that are not the standard specification, please consult your Komatsu distributor.

For the weight of the standard specification machine, see "WEIGHT TABLE (PAGE 3-149)".

NOTICE

- Use protectors to prevent the wire rope from being cut on sharp corners and to prevent the wire rope from cutting into the machine bodywork.
- When using a spreader bar, select an ample width to prevent contact with the machine.

Please consult your Komatsu distributor before carrying out lifting work.

METHOD OF TOWING MACHINE



WARNING

Injury or death could result if a disabled machine is towed incorrectly or if there is a mistake in the selection of the wire rope or drawbar.

- Always confirm that the wire rope or drawbar used for towing has ample strength for the weight of the machine being towed.
- Never use a wire rope which has cut strands (A), reduced diameter (B), or kinks (C). There is danger that the rope may break during the towing operation.
- Always wear leather gloves when handling wire rope.
- Never tow a machine on a slope.
- Never go between the towing machine and the towed machine during the towing operation.
- If the machine moves suddenly, a load is applied suddenly to the towing wire rope or drawbar, and the towing wire or drawbar may break. Move the machine gradually to a constant speed.
- Be extremely careful if there is a failure in the engine or brake system: the brakes will not work.
- If the steering and the brakes on the disabled machine cannot be operated, do not let anyone ride on the disabled machine.

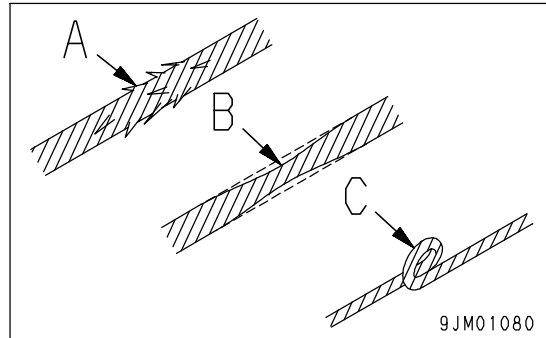

NOTICE

- The permissible towing capacity for this machine is as shown below. Do not tow any load greater than this.
WA800: 498940N (50910kg)
WA900: 524910N (53560kg)
- The machine should be towed only to a position where it is possible to carry out inspection and maintenance. This operation is only for towing short distances. Do not tow the machine for long distances.
- Please consult your Komatsu distributor for information about towing a disabled machine.

2. When starting the engine without carrying out the prelube operation, remove the two sets of connectors and connect the PRE1 and PRE2 connectors in their place.
3. Turn the key in starting switch (1) to the START position to crank the starting motor without carrying out the prelube operation.

REMARK

- Even when starting the engine without carrying out the prelube operation, when starting in cold areas, turn the key in starting switch (1) to the ON position and carry out preheating.
- When the preheating pilot lamp goes out, turn the key in starting switch (1) to the START position and start the engine.

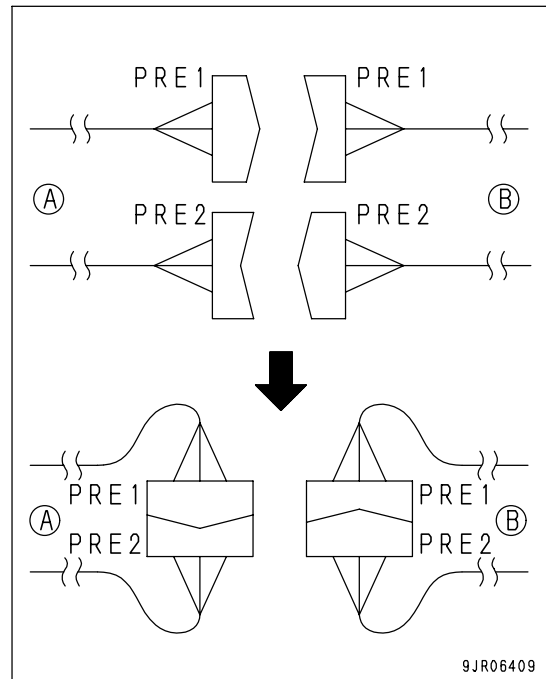

GUIDES TO MAINTENANCE

Do not perform any inspection and maintenance operation that is not found in this manual.

CHECK SERVICE METER:

Check the service meter reading every day to see if the time has come for any necessary maintenance to be performed.

KOMATSU GENUINE REPLACEMENT PARTS:

Use Komatsu genuine parts specified in the Parts Book as replacement parts.

KOMATSU GENUINE OILS:

For lubrication of the machine, use the Komatsu genuine lubricants. Moreover use oil of the specified viscosity according to the ambient temperature.

ALWAYS USE CLEAN WASHER FLUID:

Use automobile window washer fluid, and be careful not to let any dirt get into it.

ALWAYS USE CLEAN OIL AND GREASE:

Use clean oil and grease. Also, keep the containers of the oil and grease clean. Keep foreign materials away from oil and grease.

CHECKING FOR FOREIGN MATERIALS IN DRAINED OIL AND ON FILTERS:

After oil is changed or filters are replaced, check the old oil and filters for metal particles and foreign materials. If large quantity of metal particles or foreign materials are found, always report to the person in charge, and carry out suitable action.

FUEL STRAINER:

If your machine is equipped with a fuel strainer, do not remove it while fueling.

WELDING INSTRUCTIONS:

- Turn off the engine starting switch.
- Do not apply more than 200 V continuously.
- Connect grounding cable within 1 m (3.3 ft) of the area to be welded. If grounding cable is connected near instruments, connectors, etc., the instruments may malfunction.
- If a seal or bearing happens to come between the part being welded and grounding point, change the grounding point to avoid such parts.
- Do not use the area around the work equipment pins or the hydraulic cylinders as the grounding point.
- Remove the negative (-) terminal of the battery to stop the flow of electric current.

DO NOT DROP THINGS INSIDE MACHINE:

- When opening inspection windows or the oil filler port of the tank to carry out inspection, be careful not to drop nuts, bolts, or tools inside the machine.
If such things are dropped inside the machine, it may cause damage and/or malfunction of the machine, and will lead to failure. If you drop anything inside the machine, always remove it immediately.
- Do not put unnecessary things in your pockets. Carry only things which are necessary for inspection.

Capacity \ Reservoir		Engine oil pan	Transmission case	Hydraulic system	Brake oil tank	Front axle
Specified	Liters	140	164	1065	42	360
	US gal	36.96	43.3	281.16	11.09	95.0
Refill	Liters	130	140	725	31	360
	US gal	34.35	36.96	191.4	8.18	95.0

Capacity \ Reservoir		Rear axle	Pins	Fuel tank	Cooling system
Specified	Liters	360	-	1555	337
	US gal	95.0	-	410.83	89.0
Refill	Liters	360	-	-	-
	US gal	95.0	-	-	-

NOTICE

Use only diesel fuel.

The engine mounted on this machine employs electronic control and a high-pressure fuel injection device to obtain good fuel consumption and good exhaust gas characteristics. For this reason, it requires high precision for the parts and good lubrication. If kerosene or other fuel with low lubricating ability is used, there will be a big drop in durability.

Always use the fuel specified for the temperature in the Operation and Maintenance Manual.

- If the fuel is used at temperatures lower than the specified temperature (particularly at temperatures below -15° C (5°F)), the fuel will solidify.
- If the fuel is used at temperatures higher than the specified temperature, the viscosity will drop, and this may result in problems such as a drop in output.

Note 1: HTHS (High-Temperature High-Shear Viscosity 150°C), specified by ASTM D4741 must be equal to or higher than 3.5 mPa-S. Komatsu EOS0W30 and EOS5W40 are the most suitable oils.

Note 2: Powertrain oil has different properties from engine oil. Be sure to use the recommended oils.

Note .3: Axle oil AXO80 has the function of preventing squealing from the brakes and LSD (Limited Slip Differential). If only AXO80 is recommended, use Komatsu genuine AXO80 or equivalent.

Note .4: When the ambient temperature is higher than 45°C (113°F) and the machine operation hour is longer than 12 hours/day, then the use of EO50-CD instead of AXO80 is recommended. Squealing of the brakes may occur with EO50-CD, but there is no problem with the brake performance or durability.

Note. 5: If the machine is equipped with automatic greasing system, see "HANDLING AUTO-GREASING SYSTEM (PAGE 6-3)".

Note .6: Hyper grease (G2-T, G2-TE) has a high performance. When it is necessary to improve the lubricating ability of the grease in order to prevent squeaking of pins and bushings, the use of G2-T or G2-TE is recommended.

WHEN REQUIRED

CHECK, CLEAN, OR REPLACE AIR CLEANER ELEMENT

WARNING

- If inspection, cleaning, or maintenance is carried out with the engine running, dirt will get into the engine and damage it. Always stop the engine before carrying out these operations.
- When using compressed air, there is danger that dirt may be blown around and cause serious injury. Always use protective glasses, dust mask, and other protective equipment.

CHECKING

If air cleaner clogging caution pilot lamps (left, right) (1) on the maintenance monitor flash, clean the air cleaner element.

NOTICE

Do not clean the air cleaner element before the air cleaner clogging caution lamp flashes.

If the air cleaner element is cleaned frequently before the air cleaner clogging caution lamp flashes, the proper performance of the air cleaner is not provided and the cleaning efficiency is lowered.

In addition, dust sticking to the cleaner element falls on the inner element side while cleaning the element.

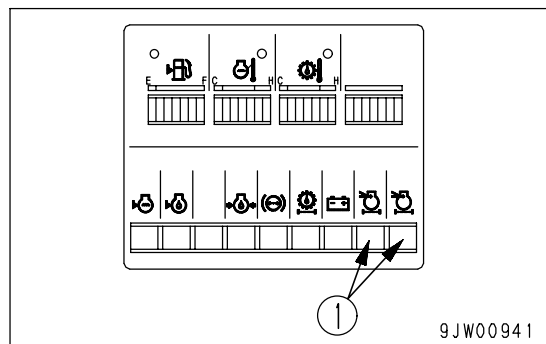

REMARK

A dust indicator (with 5-stage display) is installed to the side of the air cleaner. This displays the condition of the clogging of the air cleaner.

This makes it possible to check the clean status of the element and the replacement time.

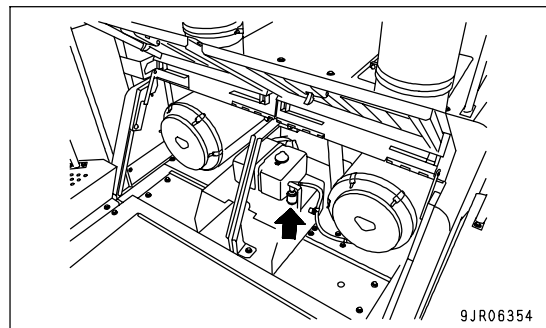

CLEAN RADIATOR, OIL COOLER, AFTERCOOLER FINS

! WARNING

If compressed air, high-pressure water, or steam hits your body directly or dirt is sent flying by the compressed air, high-pressure water, or steam, there is danger of personal injury. Always wear protective glasses, dust mask, and other protective equipment.

Carry out cleaning if any dirt or mud is seen stuck to the radiator, oil cooler, or aftercooler fins.

1. Stop the machine on horizontal ground and turn the parking brake switch ON.
2. Stop the engine.
3. Open door (1) at the side of the radiator guard, insert the nozzle between oil cooler (2) and radiator assembly (3), and use compressed air to blow out the mud or dirt out to the front and rear of the machine.
4. If the mud or dirt cannot be removed from aftercooler (4), open door (5) of the engine hood and use compressed air to blow the mud and dirt off.
5. Finally, use water to flush out the mud or dirt collected inside radiator assembly (3).

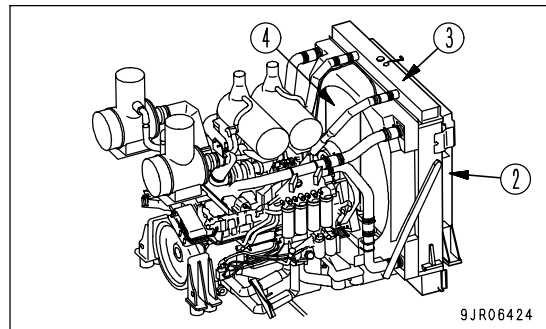
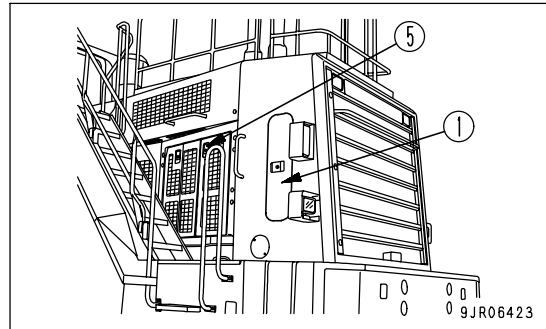

NOTICE

If steam jet nozzle (6) is brought too close to fins (7) of the radiator, oil cooler, or aftercooler, there is danger that the fins may be damaged, so keep a good distance away when cleaning.

Use the following conditions as a guideline when washing.

Jet pressure (A): Max. 9.8 MPa {100 kg/cm², 1420 PSI}

Nozzle diameter (B): Max. diameter 2 mm {0.1 in}

Distance (C) between nozzle and fin: Min. 100 mm {3.9 in}

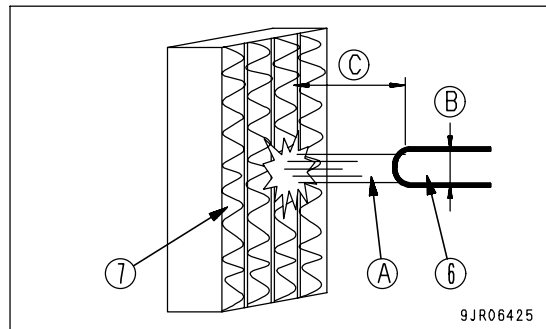

REMARK

Steam or water can be used instead of compressed air.

SELECTION AND INSPECTION OF TIRES

! WARNING

If a tire or a rim is handled improperly, the tire may burst or may be damaged and the rim may be broken and scattered, and that can cause serious injury or death.

- Since maintenance, disassembly, repair and assembly of the tires and rims require special equipment and skill, be sure to ask a tire repair shop to do the work.
- Do not heat or weld the rim to which the tire is installed. Do not make a fire near the tire.

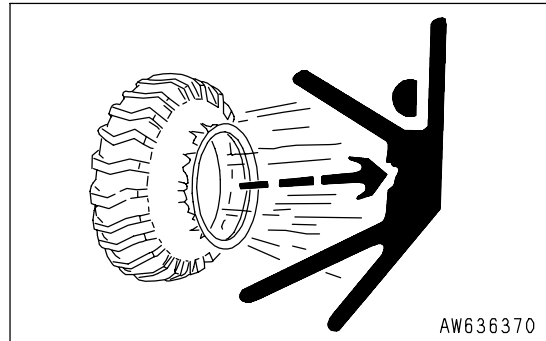

SELECTION OF TIRES

! WARNING

Select the tires according to the conditions of use and the weight of the attachments on the machine. Use only specified tires and inflate them to the specified pressure.

Select the tires according to the conditions of use and the weight of the attachments of the machine. Use the following table.

Since the travel speed indicated on the speedometer varies with the tire size, consult your Komatsu distributor when using optional tires.

WA800-3E0

	Maximum load [kg (lb)]	Tire size	Remarks
Front wheel	42865 (94517)	45/65-45-46PR (L5) (standard)	Type 3 for construction equipment
	45210 (99688)	45/65-45-50PR (L5) (if equipped)	
Rear wheel	42865 (94517)	45/65-45-46PR (L5) (standard)	
	45210 (99688)	45/65-45-50PR (L5) (if equipped)	

WA900-3E0

	Maximum load [kg (lb)]	Tire size	Remarks
Front wheel	49900 (110030)	45/65-45-58-PR (L5) (Standard)	Type 3 for construction equipment
	47500 (104737)	45/65R45☆☆ (L5) (if equipped)	
Rear wheel	49900 (110030)	45/65-45-58-PR (L5) (Standard)	
	47500 (104737)	45/65R45☆☆ (L5) (if equipped)	

CHECK ALTERNATOR BELT TENSION, ADJUST

Carry out the inspection and adjustment work after removing cover (1).

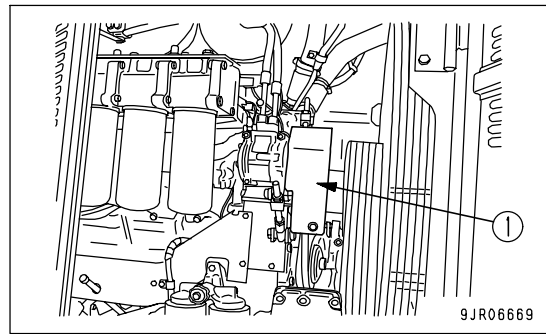

CHECKING

The belt should normally deflect by about 20 mm (0.79 in) when pressed with the finger (with a force of approx. 58.8 N (6 kg) at a point midway between the drive pulley and alternator pulley.

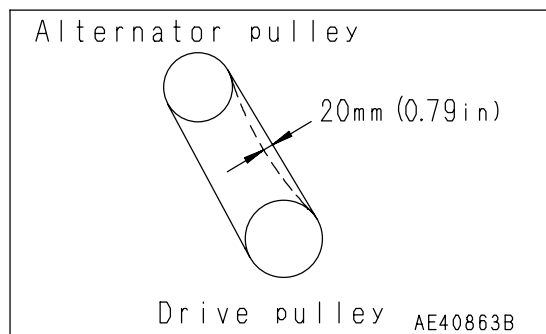
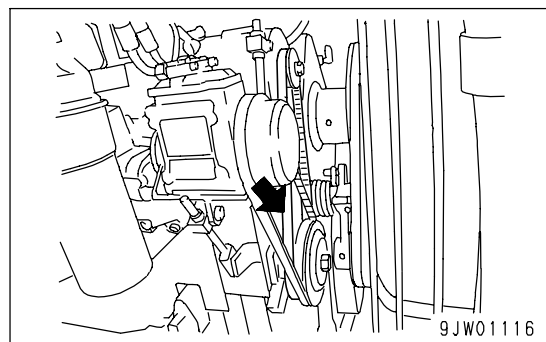

ADJUSTING

1. Loosen bolt (1) and lock nut (2).
2. Turn adjustment nut (3) to adjust the belt tension so that the deflection is approx. 20mm (0.8 in) when pressed with a finger force of approx. 58.8 N {6 kg}.
3. After adjusting, tighten locknut (2) and bolt (1).
4. Check each pulley for damage, wear of the V-groove, and wear of the V-belt. Be particularly careful to check that the V-belt is not in contact with the bottom of the V-groove.
5. If the belt has elongated and there is no more allowance for adjustment, or if the belt is cut or cracked, replace the belt. If the V-belt has been replaced with a new part, there will be initial elongation, so inspect and adjust it again after one-hour of operation.

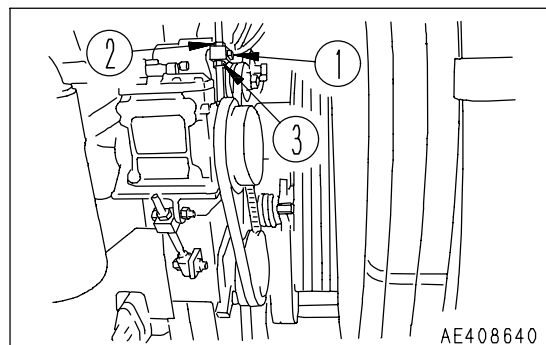

7. Remove bolt (6), then remove cover (7) and take out strainer (9) together with spring (8).
8. Remove any dirt stuck to strainer (9), then wash it in clean diesel oil or flushing oil. If strainer (9) is damaged, replace it with a new part.
9. Install spring (8) and strainer (9) to cover (7) .
Replace the O-ring on the cover with a new part, then install the cover.

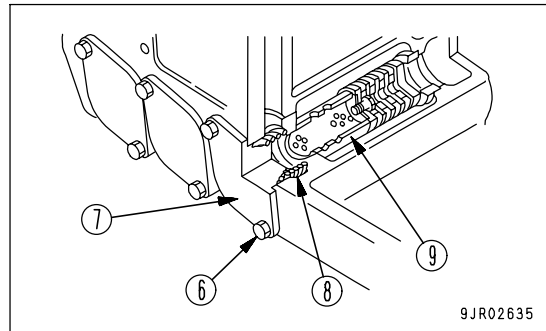
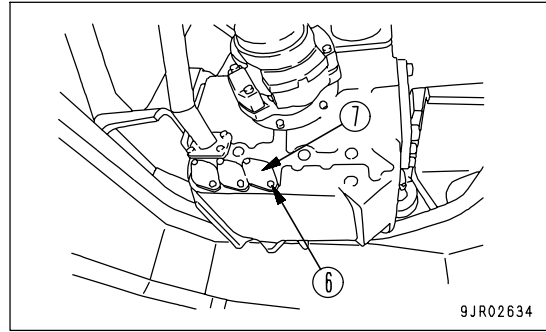

10. Pour in the specified amount of engine oil from oil filler (F).
11. After filling with oil, check that the oil is at the specified level.
For details, see "CHECK TRANSMISSION OIL LEVEL, ADD OIL (PAGE 4-29)".
12. Check that there is no leakage of oil from the transmission case or oil filter.

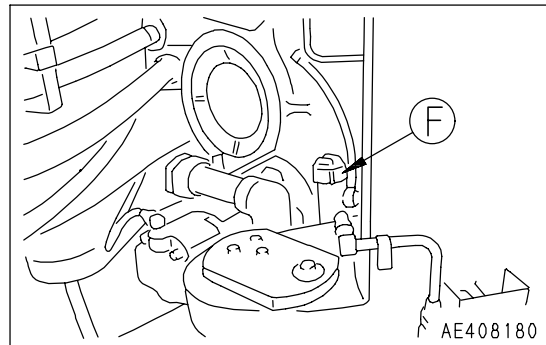

CLEAN TRANSMISSION CASE BREATHER

1. Stop the engine and wait for the temperature at all parts to go down.
2. Remove all mud and dirt from around the breather.
3. Remove the breather and fit a cover to the breather mounting hole to prevent dirt from entering.
4. Soak the breather in flushing liquid and wash it.
5. Install the breather.

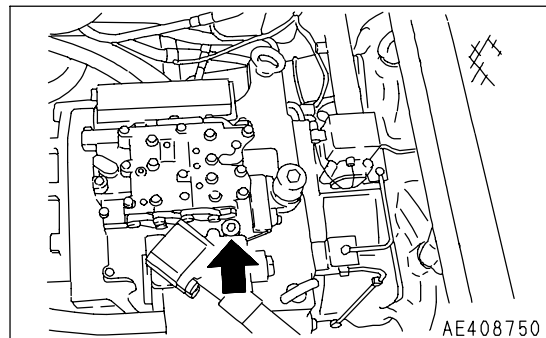

18. Loosen plug (9) installed above the tube on the suction side of the piston pump, and also loosen plug (10) installed on the elbow in the upper part of the piston pump.

There is a plug on each pump, so loosen all 6 plugs.

19. Tighten plug (9) and (10) after air is so completely bled that oil begins to run out of both plugs.
20. Check the oil level. If the oil level is low, add oil to the specified level. For details, see "CHECK OIL LEVEL IN HYDRAULIC TANK, ADD OIL (PAGE 4-48)".

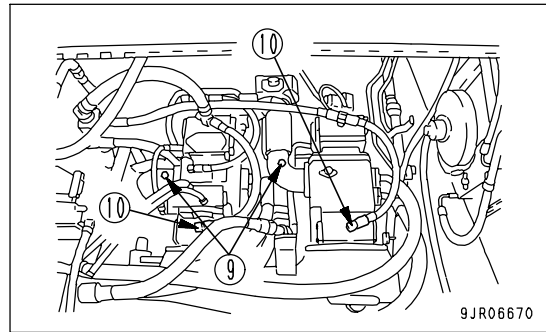

21. Fix the cap of the hydraulic tank filler port (F).
22. Run the engine at low idle, and extend and retract the steering, bucket, and lift arm cylinders 4 to 5 times. Be careful not to operate the cylinder to the end of its stroke (stop approx. 100 mm (3.9 in) before the end of stroke).

NOTICE

If the engine is run at high speed immediately after startup or a cylinder is pushed up to its stroke end, air taken inside the cylinder may cause damage to the piston packing.

23. Next, operate the steering, bucket, and lift arm cylinders to the end of their stroke 3 to 4 times, then stop the engine and loosen vent plug (1) to bleed the air from the hydraulic tank. After bleeding the air, tighten plug (1) again.

24. Check the hydraulic oil level and add oil to the specified level. For details, see "CHECK OIL LEVEL IN HYDRAULIC TANK, ADD OIL (PAGE 4-48)".

25. Next, increase the engine speed and repeat the procedure in Step 21 to bleed the air. Continue this operation until no more air comes out from plug (1).

26. After completely bleeding the air, tighten plug (1).

Tightening torque: 9.83 to 12.77 Nm (1.0 to 1.3 kgm, 7.2 to 9.4 lbft)

27. Lower the bucket horizontally to the ground and stop the engine.

28. Check that the hydraulic oil is at the standard level. For details, see "CHECK OIL LEVEL IN HYDRAULIC TANK, ADD OIL (PAGE 4-48)".

29. Check that there is no leakage of oil from the filter cover mount.

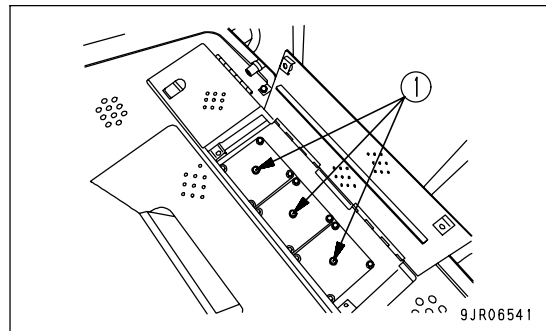

EVERY 4000 HOURS SERVICE

Maintenance for every 50, 100, 250, 500, 1000 and 2000 hours service should be carried out at the same time.

CHECK WATER PUMP

Check that there is no play in the pulley or any grease leakage, water leakage, or clogging of the drain hole. If any problem is found, contact your Komatsu distributor for disassembly and repair or replacement.

CHECK STARTING MOTOR

The brush may be worn or have no grease on the bearing, so contact your Komatsu distributor for inspection or repair.

If the engine is started frequently, carry out inspection every 1000 hours.

CHECK FAN PULLEY AND TENSION PULLEY

Check the pulley for play and leakage of grease. If there is any abnormality, please contact your Komatsu distributor for disassembly and repair or replacement.

SELECTING BUCKET AND TIRES

Select the most suitable bucket and tires for the type of work and the ground conditions on the jobsite.

WA800-3E0

(Only machines with standard 11.0m³ (14.4 cu.yd) specification)

Type of work	Bucket	Ground conditions	Tire
Loading materials and blasted rock	Straight edge rock bucket (11.0m ³ (14.39 cu.yd))	General ground conditions	45/65-45-46PR (L5)
		Hard ground	45/65-45-50PR (L5)
Loading blasted rock	Spade nose bucket (11.0m ³ (14.39 cu.yd))	General ground conditions	45/65-45-46PR (L5)
		Hard ground	45/65-45-50PR (L5)
		Ground with many boulders	45/65-45-46PR (L5)
		Soft ground with many boulders	45/65-45-50PR (L5)
			Use tire chains as a tire protector
Loading and carrying blasted rock	Spade nose bucket (11.0m ³ (14.39 cu.yd))	General ground conditions	45/65-45-46PR (L4 or L5)
		Hard ground	45/65-45-50PR (L4 or L5)
			45/65R45 ☆ ☆ (L5)
		Ground with many rocks	45/65-45-46PR (L4 or L5)
		Soft ground with many rocks	45/65-45-50PR (L4 or L5)
			45/65R45 ☆ ☆ (L5)
		Soft ground	Use tire chains as a tire protector

WA900-3E0

Type of work	Bucket	Ground conditions	Tire
Loading materials and blasted rock	Straight edge rock bucket (13.0m ³ , (17.0 cu.yd))	General ground conditions	45/65-45-58PR (L5)
		Hard ground	
Loading blasted rock	Spade nose bucket (13.0m ³ , (17.0 cu.yd))	General ground conditions	45/65-45-58PR (L5)
		Hard ground	
		Ground with many boulders	45/65-45-58PR (L5)
		Soft ground with many boulders	Use tire chains as a tire protector(*)
Loading and carrying blasted rock	Spade nose bucket (13.0m ³ , (17.0 cu.yd))	General ground conditions	45/65-45-58PR (L-5)
		Hard ground	45/65R45 ☆ ☆ (L5)
		Ground with many rocks	45/65-45-58PR (L-5)
		Soft ground with many rocks	45/65R45 ☆ ☆ (L5)
		Soft ground	Use tire chains as a tire protector(*)

The displayed travel speed changes according to the tire size, so when installing optional tires, please contact your Komatsu distributor.

On jobsites where there are boulders or sharp rocks, install tire protectors (mesh chain).

(*): In the case of WA900-3E0, do not fit a tire protector (mesh chain type) to the rear wheels.

(For further details, see "PRECAUTIONS RELATED TO PROTECTIVE STRUCTURES (PAGE 2-19)".)

Check the chain for cuts or sagging before starting operation.

Be careful not to let the tires and chain slip during operation.

2. Injector (SL11)

- 1) The injector is operated by the pressure from the pump, and it feeds grease of the specified quantity to the bearing.
- 2) To see if the injector works normally, check the operation of indicator pin (4) on its head. If the injector is normal, the pin is retracted first. If the pump stops and the pressure is lost, the pin returns and it is reset for the next greasing.
- 3) Adjust the discharge from the injector with adjustment screw (6) on its head.

- 1] To reduce the discharge, loosen lock nut (5) and turn adjustment screw clockwise. If the adjustment screw stops (at the stopper), the discharge is minimized.
- 2] If the adjustment screw is returned by 10 turns from the fully tightened position (minimum discharge) in 1] above, the discharge is maximized (8.2 cc/st).

After adjusting the discharge from the injector, be sure to tighten lock nut.

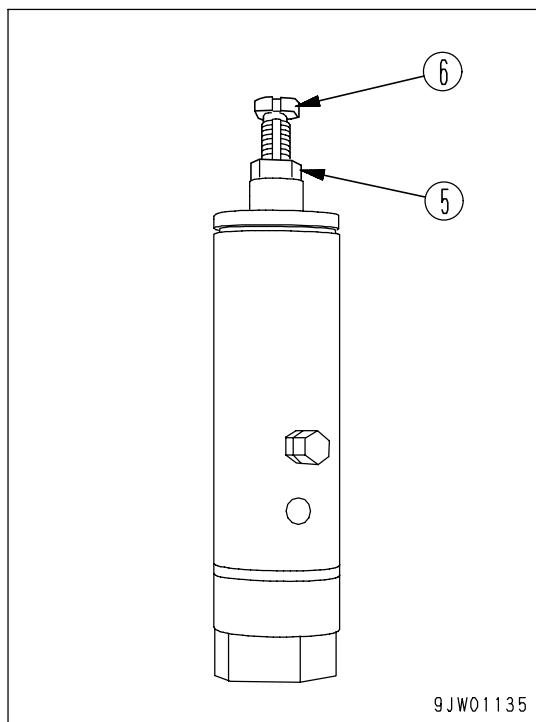

- 4) Although the injector can be overhauled and repaired, replace it with a spare one, if possible, when it has any trouble.

- Discharge adjusting procedure for large-sized injector (SL-11) (Added to bucket pin)
Loosen lock nut (5) and turn adjustment screw (6) to adjust the discharge of grease made each time.

	Discharge (cc/cycle)
Turn clockwise to stopper (Min. discharge)	0.82
Turn counterclockwise by 10 turns from above position (Max. discharge)	8.2

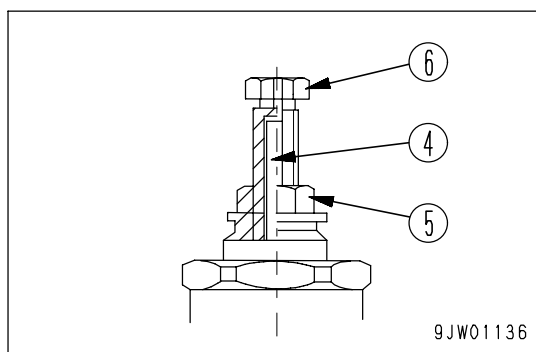

One turn between the maximum and minimum positions change the discharge by 0.82 cc.
After adjusting the discharge, be sure to tighten the lock nut.

EMERGENCY ENGINE STOP SWITCH

WA900-3E0

An emergency engine stop switch is provided in the operator's cab and two other spots on the machine's periphery (3 spots total). If any one of them is pressed, the engine stops. Use this switch only in emergency, and for normal starting and stopping of the engine, use the engine starting switch.

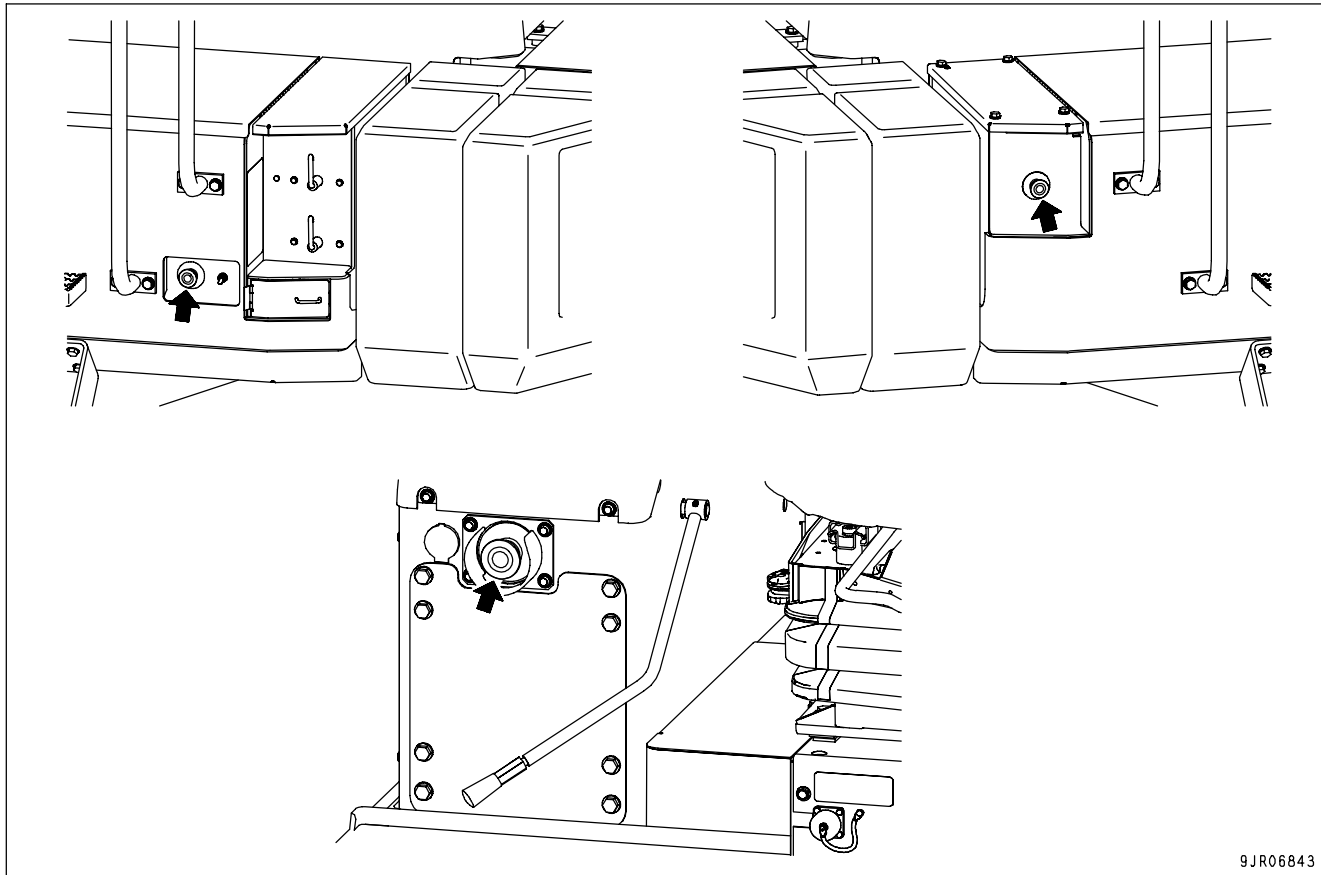

9JR06843

1. Press the nearest emergency engine stop switch, and the engine stops.

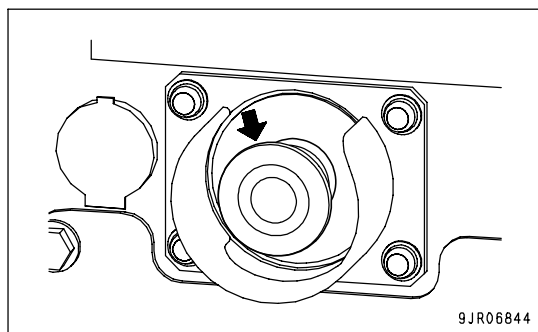

9JR06844

2. If the engine remains in a standstill for a while, turn off the engine starting switch in the operator's cab.
(If any of the lights is kept on, the battery can run down.)
3. Remove the cause that necessitated the engine to stop all of sudden.

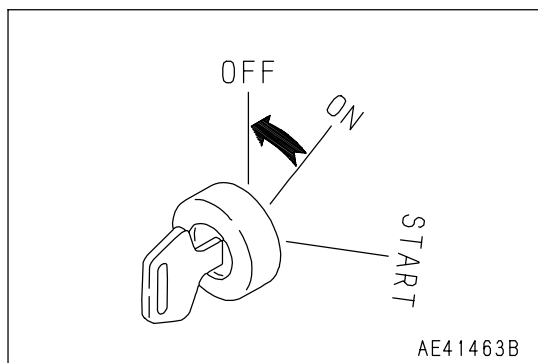

AE41463B

CLICK HERE TO **DOWNLOAD** THE COMPLETE MANUAL

- Thank you very much for reading the preview of the manual.
- You can download the complete manual from: www.heydownloads.com by clicking the link below



- Please note: If there is no response to CLICKING the link, please download this PDF first and then click on it.

CLICK HERE TO **DOWNLOAD** THE COMPLETE MANUAL