

Operation & Maintenance Manual

WA700-3

WHEEL LOADER

SERIAL NUMBERS **WA700-3 - 50001** and up

This material is proprietary to Komatsu America International Company and is not to be reproduced, used, or disclosed except in accordance with written authorization from Komatsu America International Company.

It is our policy to improve our products whenever it is possible and practical to do so. We reserve the right to make changes or add improvements at any time without incurring any obligation to install such changes on products sold previously.

Due to this continuous program of research and development, periodic revisions may be made to this publication. It is recommended that customers contact their distributor for information on the latest revision.

CLICK HERE TO **DOWNLOAD** THE COMPLETE MANUAL

- Thank you very much for reading the preview of the manual.
- You can download the complete manual from: www.heydownloads.com by clicking the link below



- Please note: If there is no response to CLICKING the link, please download this PDF first and then click on it.

CLICK HERE TO **DOWNLOAD** THE COMPLETE MANUAL

6. GENERAL PRECAUTIONS

⚠ WARNING: For reasons of safety, always follow these safety precautions.

SAFETY RULES

- Only trained and authorized personnel can operate and maintain the machine.
- Follow all safety rules, precautions and instructions when operating or performing maintenance on the machine.
- Do not operate the machine if you are not feeling well, or if you are taking medicine which will make you sleepy, or if you have been drinking. Operating in such a condition will adversely affect your judgement and may lead to an accident.
- When working with another operator or with a person on worksite traffic duty, be sure that all personnel understand all hand signals that are to be used.
- Always follow all rules related to safety.

SAFETY FEATURES

- Be sure all guards and covers are installed in their proper position. Have guards and covers repaired immediately if damaged.
Proper position → See "12.1.1 WALK-AROUND CHECK"
- Use safety features such as safety lock lever ① and seat belts properly.
- NEVER remove any safety features. ALWAYS keep them in good operating condition.
Safety lock lever → See "12.13 PARKING MACHINE"
Seat belts → See "12.1.3 ADJUSTMENT BEFORE OPERATION"
- Improper use of safety features could result in serious bodily injury or death.

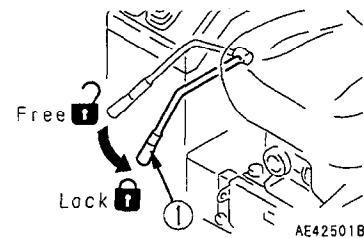

CLOTHING AND PERSONAL PROTECTIVE ITEMS

- Avoid loose clothing, jewelry, and loose long hair. They can catch on controls or in moving parts and cause serious injury or death.
- Also, do not wear oily clothes, because they are flammable.
- Wear a hard hat, safety glasses, safety shoes, mask or gloves when operating or maintaining the machine. Always wear safety goggles, hard hat and heavy gloves if your job involves scattering metal chips or minute materials particularly when driving pins with a hammer and when cleaning the air cleaner element with compressed air. Check also that there is no one near the machine.
- Check that all protective equipment functions properly before using.

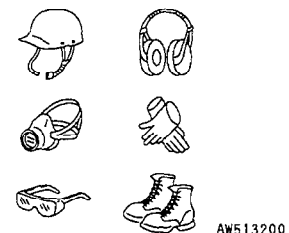

PRECAUTIONS WHEN TRAVELING

- Never turn the key in the starting switch to the OFF position when traveling. It is dangerous if the engine stops when the machine is traveling, because the steering becomes heavy. If the engine stops, apply the brake immediately to stop the machine.
- It is dangerous to look around you when operating. Always concentrate on your work.
- It is dangerous to drive too fast, or to start suddenly, stop suddenly, turn sharply, or zigzag.
- If you find any abnormality in the machine during operation (noise, vibration, smell, incorrect gauges, air leakage, oil leakage, etc.), move the machine immediately to a safe place and look for the cause.
- Set the work equipment to a height of 72 – 85 cm (28.3 – 33.5 in) from the ground level and travel on level ground.
- When traveling, do not operate the work equipment control levers. If the work equipment control levers have to be operated, stop the machine first, then operate the levers.
- Do not operate the steering wheel suddenly. The work equipment may hit the ground surface and cause the machine to lose its balance, or may damage the machine or structures in the area.
- When traveling on rough ground, travel at low speed, and avoid sudden changes in direction.
- Avoid traveling over obstacles as far as possible. If the machine has to travel over an obstacle, keep the work equipment as close to the ground as possible and travel at low speed.
- When traveling or carrying out operations, always keep your distance from other machines or structures to avoid coming into contact with them.
- NEVER be in water which is in excess of the permissible water depth.
Permissible water depth → See "12.11 PRECAUTIONS FOR OPERATION".
- When passing over bridges or structures on private land, check first that the structure is strong enough to support the mass of the machine. When traveling on public roads, check first with the relevant authorities and follow their instructions.
- Always obey the traffic regulations when traveling on public roads. This machine travels at a lower speed than normal automobiles, so keep to the side of the road and be careful to leave the center of the road free for other vehicles.
- If you drive the machine at high speed continuously for a long time, the tires will overheat and the internal pressure will become abnormally high. This may cause the tires to burst. If a tire bursts, it produces an extremely large destructive force, and this may cause serious injury or accident.
- If you are going to travel continuously, please consult your Komatsu distributor.

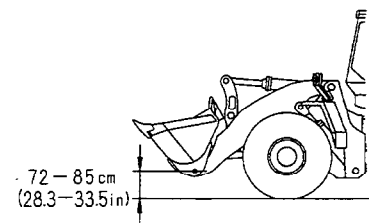

8. PRECAUTIONS FOR MAINTENANCE

⚠ WARNING: For reasons of safety, always follow these safety precautions.

8.1 BEFORE CARRYING OUT MAINTENANCE

NOTIFICATION OF FAILURE

Carrying out maintenance not described in the Komatsu operation and maintenance manual may lead to unexpected failures.
Please contact your Komatsu distributor for repairs.

WARNING TAG

- If others start the engine or operate the controls while you are performing service or lubrication, you could suffer serious injury or death.
- ALWAYS attach the WARNING TAG to control lever ① in the operator's cab to alert others that you are working on the machine. Attach additional warning tags around the machine, if necessary.
- These tags are available from your Komatsu distributor. (Part No. 09963-03000)

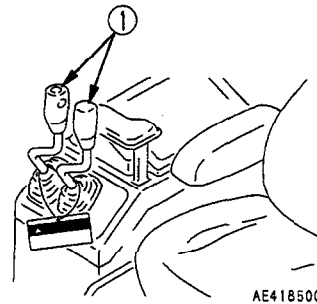
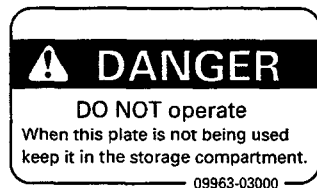

AE418500

CLEAN BEFORE INSPECTION AND MAINTENANCE

- Clean the machine before carrying out inspection and maintenance. This will ensure that dirt does not get into the machine and will also ensure that maintenance can be carried out safely.
- If inspection and maintenance are carried out with the machine still dirty, it will be difficult to find the location of problems, and there is also the danger that you will get dirty or mud in your eyes, and that you will slip and injure yourself.
- When washing the machine, always do as follows.
 - Wear non-slip shoes to prevent yourself from slipping on the wet surface.
 - When using high-pressure steam to wash the machine, always wear protective clothing. This will protect you from being hit by high-pressure water, and cutting your skin or getting mud or dust into your eyes.
 - Do not spray water directly on to the electrical system (sensors, connectors) ①. If water gets into the electrical system, there is danger that it will cause defective operation and malfunction.

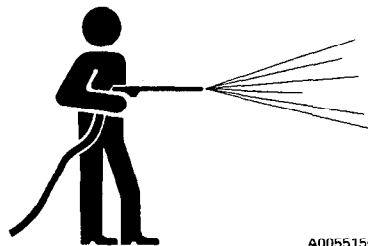

A0055150

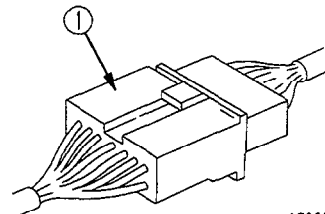

AE305820

TIRE MAINTENANCE

Disassembly, repair, and assembly of tires requires specialist equipment and skill, so please ask your specialist tire repair shop to carry out repairs.

CHECKS AFTER INSPECTION AND MAINTENANCE

Failure to carry out inspection and maintenance fully, or failure to check the function of various maintenance locations may cause unexpected problems and may even lead to personal injury or damage, so always do as follows.

- Checks when engine is stopped
 - Have all the inspection and maintenance locations been checked?
 - Have all the inspection and maintenance items been carried out correctly?
 - Have any tools or parts dropped inside the machine? It is particularly dangerous if they get caught in the lever linkage.
 - Has water and oil leakage been repaired? Have bolts been tightened?
- Checks when engine is running

For details of checks when the engine is running, see "8.2 DURING MAINTENANCE, MAINTENANCE WITH ENGINE RUNNING", and be extremely careful to ensure safety.

 - Do the inspection and maintenance locations work normally?
 - Is there any oil leakage when the engine speed is raised and load is applied to the hydraulic system?

WASTE MATERIALS

To prevent pollution, particularly in places where people or animals are living, always follow the procedures given below.

- Never dump waste oil in a sewer system, rivers, etc.
- Always put oil drained from your machine in containers. Never drain oil directly on the ground.
- Obey appropriate laws and regulations when disposing of harmful objects such as oil, fuel, coolant, solvent, filters, batteries, and others.

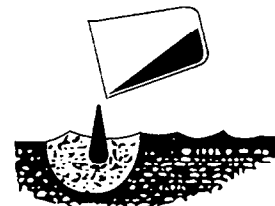

A0055220

MAINTENANCE OF AIR CONDITIONER

If the air conditioner refrigerant gets into your eyes or touches your skin, it may cause blindness or frostbite.

- When handling the refrigerant, follow the precautions given on the container.
- To prevent the refrigerant from leaking into the atmosphere, use a recovery recycling system.
- Never touch the refrigerant.

10.2 GENERAL VIEW OF CONTROLS AND GAUGES

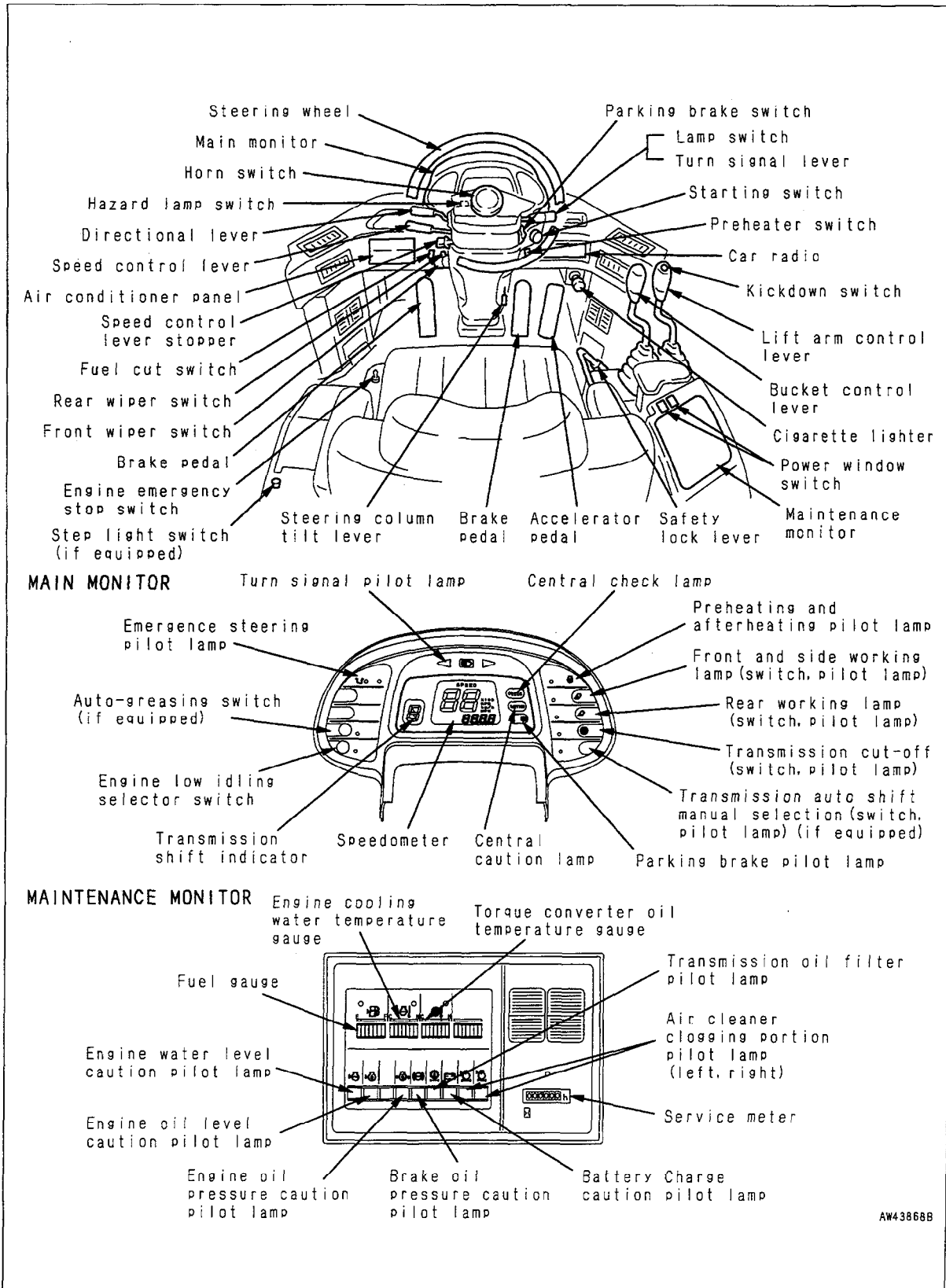

11. SERVICE METER

This meter shows the total operation hours of the machine.
 The service meter advances while the engine is running - even if the machine is not traveling.

While the engine is running, green pilot lamp on the service meter flashes to show the service meter advances.

The service meter progresses by 1 when the engine is operated for one hour, regardless of the engine speed.

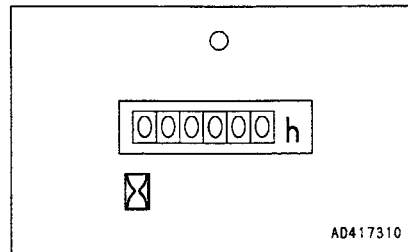

12. SPEEDOMETER

This meter indicates the travel speed of the machine.

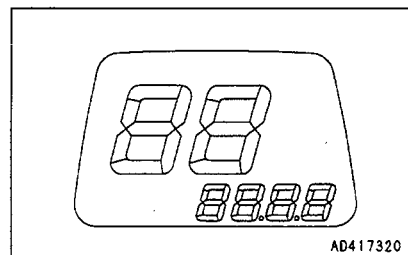

13. TRANSMISSION SHIFT INDICATOR

This indicates the present speed range of the transmission.

When the directional lever is at the N position, N is displayed on the indicator.

When the directional lever is at the F or R position, the shift position of the speed lever is displayed as a numeral.

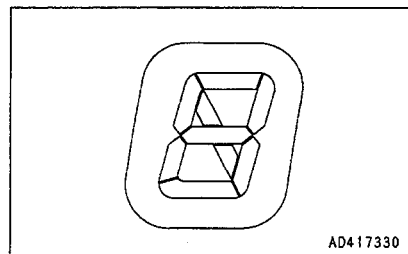

WHEN USING JOYSTICK STEERING SYSTEM (if equipped)

This indicates the transmission speed range. When the N button of the FNR buttons on the head of the joystick lever is pressed, the indicator displays N.

When the F (FORWARD) or R (REVERSE) buttons of the FNR buttons on the head of the joystick lever are pressed, F or R is displayed at the bottom of the speedometer and the shift indicator displays the transmission speed range and N.

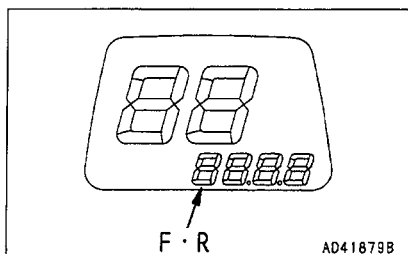
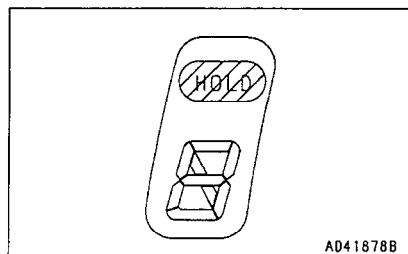

11.3 CONTROL LEVERS, PEDALS

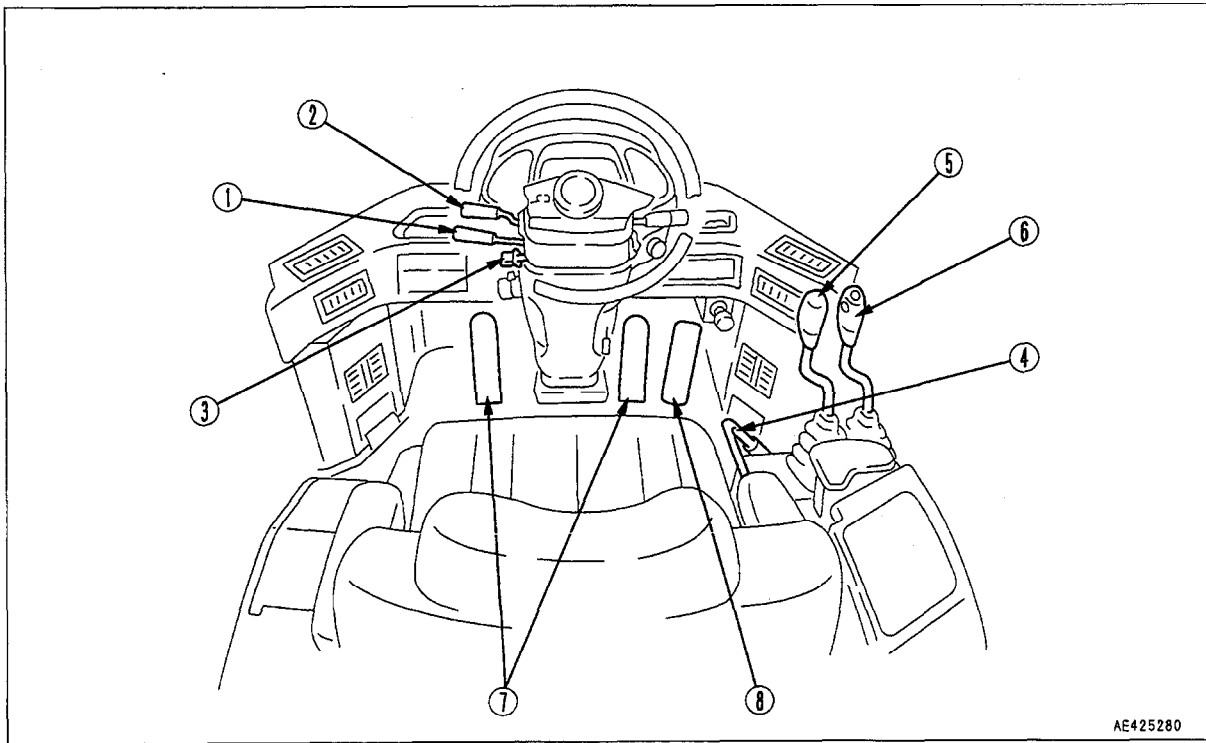

AE425280

1. SPEED CONTROL LEVER

This lever controls the travel speed of machine.

MANUAL SHIFT SYSTEM

This machine has a 4-FORWARD, 4-REVERSE speed transmission.

Place the speed control lever in a suitable position to obtain the desired speed range.

1st and 2nd speeds are used for working.

3rd and 4th speeds are used for traveling.

However, when the speed control lever stopper is being used, it is impossible to shift to 3rd or 4th. Disengage the speed control lever stopper before trying to shift gear.

- Position ①: 1st
- Position ②: 2nd
- Position ③: 3rd
- Position ④: 4th

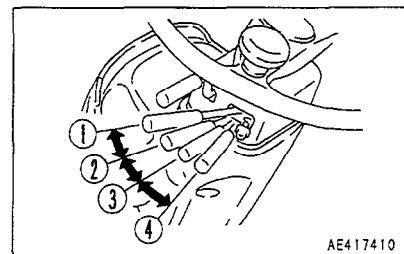

AE417410

REMARK

The length of the lever can be adjusted to 3 stages (positions A, B, C). To adjust the length, remove the screw at the bottom of the lever knob, slide the knob to the desired position, then tighten the screw again.

(The lever is installed to position B when it is shipped from the factory.)

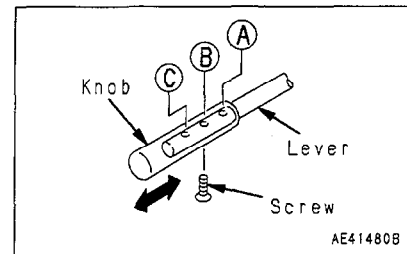

AE414808

Fuse box II

No.	Fuse capacity	Name of circuit
①	20A	Front working lamp
②	20A	Rear working lamp
③	30A	Air conditioner 1 (if equipped)
④	20A	Air conditioner 2 (if equipped)
⑤	20A	Wiper, washer
⑥	20A	Side working lamp
⑦	10A	Cigarette lighter, radio (if equipped)
⑧	10A	Rotating lamp (if equipped)
⑨	30A	APS
⑩	10A	Auto-greasing (if equipped)
⑪	20A	L.H. power window
⑫	20A	R.H. power window
⑬	10A	Air suspension seat
⑭	10A	Spare
⑮	10A	Engine controller

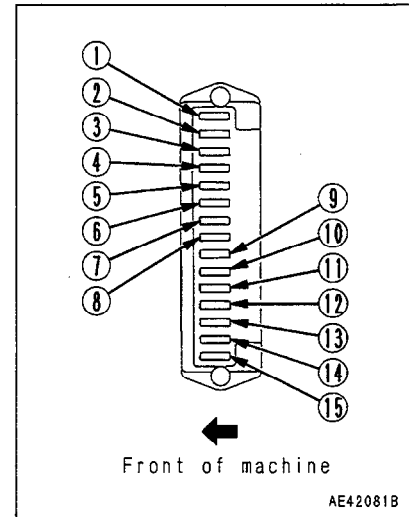

11.14 SLOW-BLOW FUSE

If the power does not come on when the starting switch is turned ON, the slow-blow fuse may be blown, so check and replace it.

The slow blow fuse is beside the engine on the right side of the machine.

SLOW-BLOW FUSE

- ① 80A: Main power
- ② 30A: Battery power (starting switch, hazard)

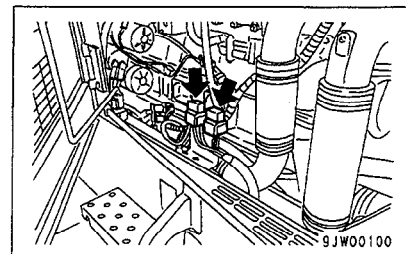

11.19.2 OPERATION METHOD

PRESETTING TO SELECTED STATIONS

When listening to a preset station, select one of the AM, FM1, FM2 and FM3 bands using band select switch ①, then simply press the number key corresponding to the preset selected station.

The system can memorize 6 stations in AM band and 18 stations in FM bands (FM1: 6 stations, FM2: 6 stations and FM3: 6 stations).

1. If the system is playing a cassette tape, press the eject button to stop the tape.
2. Tune to the desired station for presetting:
First, select one of the MW (AM), FM1, FM2 and FM3 bands with band select switch ①, then tune to the frequency of the desired station using the TUNING buttons.
3. Press memory switch ②.
4. While memory switch ② is flashing, press the preset switch ③ of the number to be preset. (The preset channel and frequency will be indicated. This concludes presetting.)
5. Repeat the above procedure Steps 2 to 4 to preset to other desired stations.

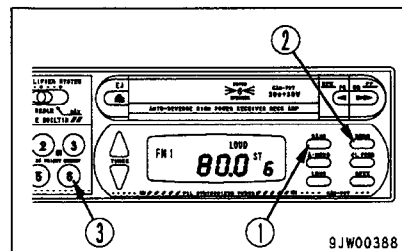

REMARK

- To change the station in a preset switch, repeat the above procedure Steps 2 to 4.
- If the main power supply is interrupted, such as when exchanging the machine battery, all presetting will be erased. Repeat the presetting procedure in such cases.

AUTO-MEMORY

When the auto-memory switch ① is pressed, the system tunes itself to stations receivable in the area where the machine is currently located, one after another, and memorizes the frequencies in its preset-memory, all automatically.

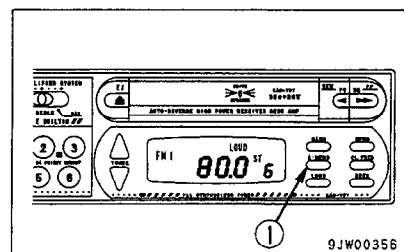

11.22 PRECAUTIONS WHEN HANDLING ACCUMULATOR

WARNING

The accumulator is charged with high-pressure nitrogen gas, which is extremely dangerous, so read the following items and be careful to handle the accumulator properly.

- If any problem or failure occurs with the accumulator, please contact your Komatsu distributor immediately.
- The gas must be charged only by a serviceman from your Komatsu distributor or by a person licensed to handle high-pressure gas.
- Do not strike or bring any flame or heat close to the accumulator when it is charged with gas.
- Do not make any hole or weld any boss to the accumulator.
- Always release the gas before disposing of the accumulator or disassembling it for maintenance.
- Use the air bleed valve to release the gas.
- Every 2000 hours or once a year, please contact your Komatsu distributor to have the gas pressure checked.

The accumulator for the brake is installed on the side of the brake component box on the left side of the rear frame.

The accumulator for the PPC valve is installed to the inside under the center platform.

When handling the accumulators, be extremely careful.

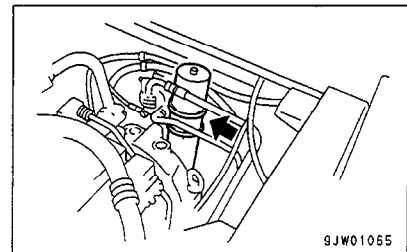
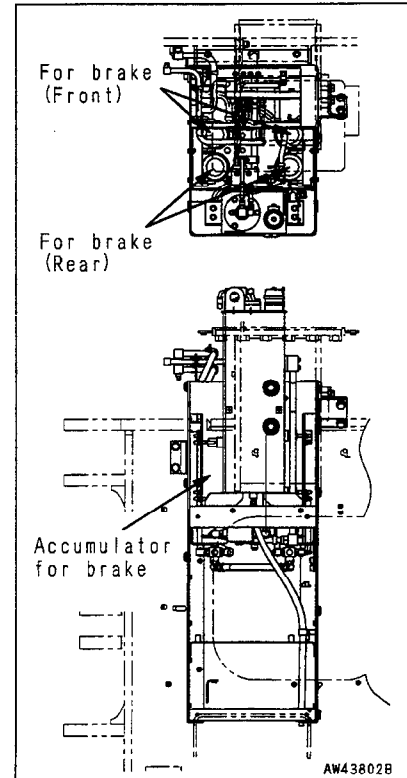
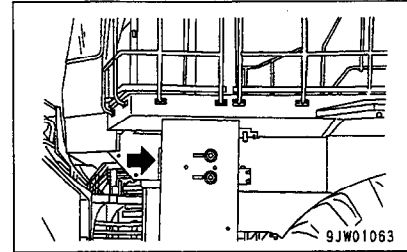

CHECK EFFECT OF PARKING BRAKE**⚠ WARNING**

Even if the parking brake switch is turned ON, there is danger until the parking brake pilot lamp lights up, so keep the brake pedal depressed.

Measurement conditions

- Tire inflation pressure: Specified pressure
- Road surface: Dry paved surface with 1/5 (11°20') grade
- Machine: Operating condition

Method of measurement

1. Turn the key in the starting switch to the ON position and start the engine, set the machine facing straight to the front, then drive the machine up a 1/5 grade with the bucket empty.
2. Depress the brake pedal, stop the machine, return the directional lever to the neutral position, then stop the engine.
3. Press the parking brake switch to the ON position, release the brake pedal slowly, and check that the machine is held in position.

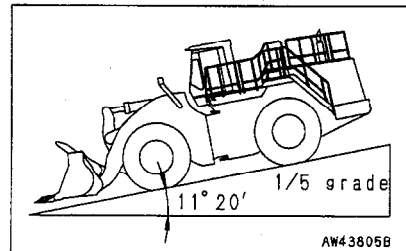
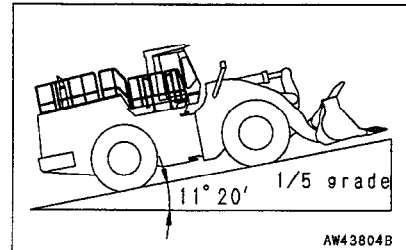
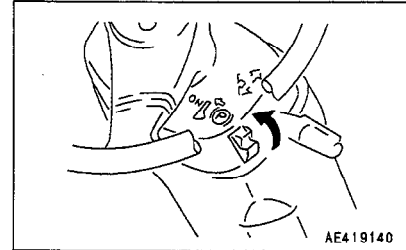
**CHECK EFFECT OF BRAKE**

Drive the machine at a speed of 20 km/h (12.4 MPH) on a dry flat concrete road surface, and check that the stopping distance is less than 6.5 m (21 ft 4 in).

CHECK SOUND OF HORN AND BACKUP BUZZER**CHECK FLASHING OF LAMPS, CHECK FOR DIRT OR DAMAGE****CHECK DIRECTION OF REAR VIEW MIRROR, CHECK FOR DIRT OR DAMAGE****CHECK ENGINE EXHAUST COLOR AND SOUND****CHECK OPERATION OF GAUGES****CHECK PLAY OF STEERING WHEEL, CHECK OPERATION OF STEERING****CHECK FOR WATER AND SEDIMENT IN WATER SEPARATOR, DRAIN WATER (IF EQUIPPED)**

The water separator separates water mixed in the fuel. If float ② is at or above red line ①, drain the water.

For the draining procedure, see section "24.2 WHEN REQUIRED".

Even if a water separator is installed, be sure to check the fuel tank to remove water and sediment in the fuel.

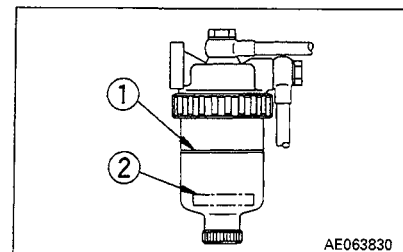

5. After starting, put preheater switch ② in OFF position.

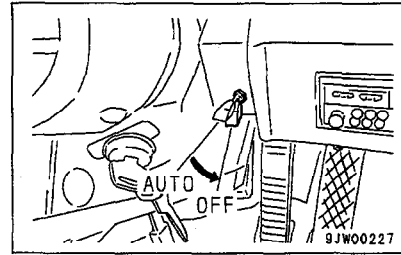

The standard specification machine is designed to work in ambient temperature from -20 to 40°C .

When operating the machine at temperatures below -20°C , special equipment is needed. Contact your Komatsu distributor for details.

For machines where the air dryer is installed as an option, in cold temperatures below -10°C , when operating the machine after it has been stopped for several hours, run the engine for at least 10 minutes after starting before moving the machine.

- When digging and loading on level ground, set the bucket edge facing down slightly as follows and drive the machine forward. Always be careful not to load the bucket on one side and cause an unbalanced load.

This operation should be carried out in 1st gear.

⚠ WARNING

Do not set the bucket facing down more than 20°.

1. Set the edge of the bucket facing slightly down.

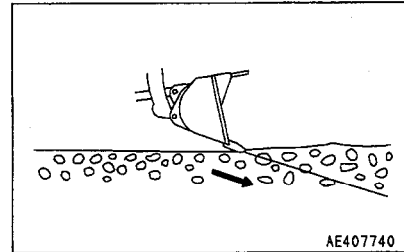

2. Drive the machine forward and operate the lift arm control lever forward to cut a thin layer of the surface each time when excavating the soil.

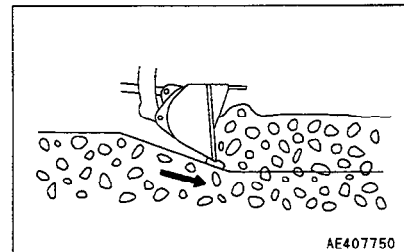

3. Operate the lift arm control lever slightly up and down to reduce the resistance when driving the machine forward.

When digging with the bucket, avoid imposing the digging force onto only one side of the bucket.

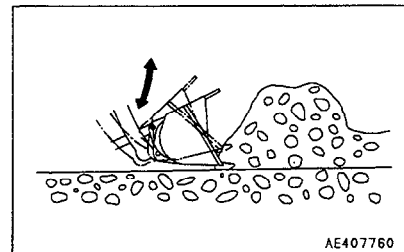

CLICK HERE TO **DOWNLOAD** THE COMPLETE MANUAL

- Thank you very much for reading the preview of the manual.
- You can download the complete manual from: www.heydownloads.com by clicking the link below



- Please note: If there is no response to CLICKING the link, please download this PDF first and then click on it.

CLICK HERE TO **DOWNLOAD** THE COMPLETE MANUAL

12.18 HANDLING THE TIRES

12.18.1 PRECAUTIONS WHEN HANDLING TIRES

CAUTION

If a tire has reached any of the following service limits, there is danger that the tire may burst or cause an accident, so to ensure safety, replace it with a new tire.

- **Service limits for wear**
 - When the remaining depth of the groove on construction equipment tires (at a point approx. 1/4 of the tread width) is 15% of the groove depth on a new tire.
 - When the tire shows marked uneven wear, stepped wear or other abnormal wear, or when the cord layer is exposed.
- **Service limits for damage**
 - When there is external damage extending to the cord or when the cord is broken
 - When the cord is cut or there is dragging
 - When the tire is peeling (there is separation)
 - When the bead is damaged
 - For tubeless tires, when there is air leakage or improper repair

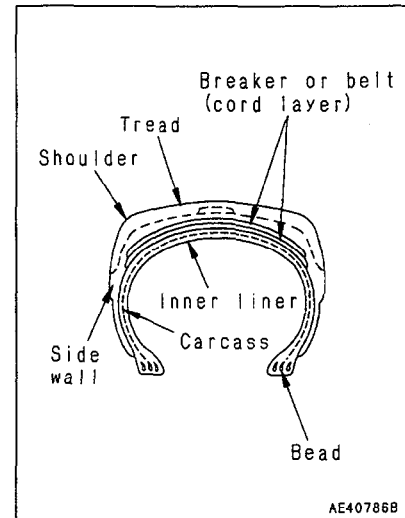

Please contact your Komatsu distributor when replacing the tires. It is dangerous to jack up the machine without taking due care.

12.18.2 TIRE PRESSURE

Measure the tire pressure before starting operations, when the tires are cool.

If the tire inflation pressure is too low, there will be overload; if it is too high, it will cause tire cuts and shock burst. To prevent these problems, adjust the tire inflation pressure according to the table on the next page.

$$\text{Deflection ratio} = \frac{H - h}{H} \times 100$$

The diagram shows a cross-section of a tire. The total height is labeled H, and the height of the deflected portion is labeled h. The deflection ratio is calculated as (H - h) / H x 100.

As a guideline that can be checked visibly, the deflection ratio of the front tire (deflection/free height) is as follows.

When carrying normal load (lift arm horizontal): Approx. 10 – 15%

When digging (rear wheels off ground): Approx. 15 – 20%

When checking the tire inflation pressure, check also for small scratches or peeling of the tire, for nails or pieces of metal which may cause punctures, and for any abnormal wear.

Clearing fallen stones and rocks from the operating area and maintaining the surface will extend the tire life and give improved economy.

- For operations on normal road surfaces, rock digging operations:
 - High end of range in air pressure chart
- Stockpile operations on soft ground:
 - Average pressure in air pressure chart
- Operations on sand (operations not using much digging force)
 - Low end of range in air pressure chart

14.4 WARMING-UP OPERATION FOR STEERING HYDRAULIC CIRCUIT IN COLD WEATHER

⚠ WARNING

If the steering wheel is turned and stopped while the oil temperature is low, it may take some time for the vehicle to stop turning. In this case, perform the warm-up operation in a wider place, secure safety with the safety bar. Do not relieve the hydraulic oil in the circuit continuously for more than 5 seconds.

When the temperature is low, do not start the operation of the vehicle soon after starting the engine.

Warming up the steering hydraulic circuit

Slowly turn the steering wheel to the right and left to warm up the oil in the steering valve. (Repeat this operation for about 10 minutes to warm up the oil.)

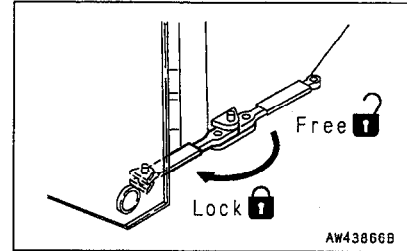

NOTICE

Turn the steering wheel a little and stop there. Then, confirm that the vehicle is steered by the angle equivalent to the turning angle of the steering wheel.

● **Recommended oil**

Select the oil depending on the temperature as shown in the following table.

	Type of oil	Temperature						
		-30	-20	-10	0	10	20	30°C
Hydraulic oil	Engine oil			SAE10WCD				
			SAE5W-20CD					

Even if SAE5W-20CD is used in low-temperature areas, always carry out the warming-up operation without fail.

If SAE5W-20CD is used in a cold season, replace it with SAE10WCD after the cold season.

16.4 OTHER TROUBLE

16.4.1 ELECTRICAL SYSTEM

- (): Always contact your Komatsu distributor when dealing with these items.
- In cases of abnormalities or causes which are not listed below, please contact your Komatsu distributor for repairs.

Problem	Main causes	Remedy
Lamp does not glow brightly even when the engine runs at high speed	<ul style="list-style-type: none"> ● Defective wiring ● Defective adjustment of alternator belt tension 	<ul style="list-style-type: none"> ● Check, repair loose terminals, disconnections ● Adjust alternator belt tension For details, see EVERY 250 HOURS SERVICE
Lamp flickers while engine is running		
Even when the engine is rotating, the charge caution pilot lamp does not go out	<ul style="list-style-type: none"> ● Defective alternator ● Defective wiring 	<ul style="list-style-type: none"> ● Replace ● Check, repair
Abnormal noise is generated from alternator	<ul style="list-style-type: none"> ● Defective alternator 	<ul style="list-style-type: none"> ● Replace
Starting motor does not turn when starting switch is turned to ON	<ul style="list-style-type: none"> ● Defective wiring ● Insufficient battery charge ● Defective starting motor 	<ul style="list-style-type: none"> ● Check, repair ● Charge ● Replace
Pinion of starting motor keeps going in and out	<ul style="list-style-type: none"> ● Insufficient battery charge 	<ul style="list-style-type: none"> ● Charge
Starting motor turns engine sluggishly	<ul style="list-style-type: none"> ● Insufficient battery charge ● Defective starting motor 	<ul style="list-style-type: none"> ● Charge ● Replace
Starting motor disengages before engine starts	<ul style="list-style-type: none"> ● Defective wiring ● Insufficient battery charge 	<ul style="list-style-type: none"> ● Check, repair ● Charge
Preheating pilot lamp does not light up	<ul style="list-style-type: none"> ● Defective wiring ● Defective controller ● Defective monitor 	<ul style="list-style-type: none"> ● Check, repair ● Replace ● Replace
Even when engine is stopped, charge caution pilot lamp does not light up (starting switch at ON position)	<ul style="list-style-type: none"> ● Defective wiring ● Defective monitor 	<ul style="list-style-type: none"> ● Check, repair ● Replace
Outside of glow plug is not warm when touched by hand	<ul style="list-style-type: none"> ● Defective wiring ● Disconnection in glow plug ● Defective operation of heater relay switch 	<ul style="list-style-type: none"> ● Check, repair ● Replace ● Replace

Fire prevention:

Use nonflammable cleaner or light oil for cleaning parts. Keep flame or cigarette light away from light oil.

Clamp faces:

When O-rings or gaskets are removed, clean the clamp faces and replace the O-rings and gaskets with new ones. Be sure to fit O-rings and gaskets when assembling.

Objects in your pockets:

Keep your pockets free of loose objects which can fall out and drop into the machinery; especially when you work on the machinery while bending over it.

Checking undercarriage:

When working in rocky areas, check for damage to the undercarriage and for looseness, flaws, wear and damage in bolts and nuts.

Precautions when washing machine:

- Never spray steam or water directly at the radiator.
- Do not allow water to get on any electrical component.

Pre-and post-work checks:

Before starting work in mud, rain, snow or at the seashore, check plugs and valves for tightness.

Wash the machine immediately after the work to protect components from rusting.

Lubricate components more frequently than usual. Be sure to lubricate work equipment pins daily if they are submerged in water.

On jobsites where heavy-duty operations are common, reduce the maintenance intervals and carry out greasing more frequently.

Dusty worksites:

When working at dusty worksites, do as follows:

- Clean the radiator core frequently to avoid clogging.
- Clean and replace the fuel filter frequently.
- Clean electrical components, especially the starting motor and alternator, to avoid accumulation of dust.

Avoid mixing oils:

Never mix oils of different brands. If you have only oil which is a different brand from the one that is used in the machine, do not add it but replace all the oil.

Greasing the rod end:

Because the rod end is of the oilless type, no greasing is required, although a grease nipple is fit to the rod end on the lever linkage.

The rod end should be greased only when it becomes stiff after using it for long span of time.

Controller:

The controller for the machine monitor may be mistakenly actuated by interference from external electric waves. For this reason, when installing a radio or other such device, please consult your Komatsu distributor.

21. STANDARD TIGHTENING TORQUES FOR BOLTS AND NUTS

21.1 INTRODUCTION OF NECESSARY TOOLS

The following tools are provided with the machine.

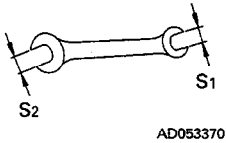
No.	Name of tool	Part No.	Remarks
1	Wrench set	09000-30006	Applicable width across flats (S_1 - S_2) 8mm – 10mm, 12mm – 14mm 13mm – 17mm 19mm – 22mm 24mm – 27mm 30mm – 32mm
			 <p style="text-align: right; margin-right: 50px;">AD053370</p>
2	Socket wrench set	09020-10284	
3	Screwdriver	09033-00190	Crosshead/flat head interchangeable type
4	Wrench	09014-10200	
5	Pliers	09036-00150	
6	Wrench	09001-03600	36 jaw
7	Filter wrench	09019-08035	For filter cartridge
8	Bar	424-98-11130	Extension bar
9	Gauge	09289-10000	
10	Thickness gauge	09054-00009	
11	Grease pump	07952-80003	For greasing work
12	Nozzle	07951-31400	Hose nozzle for grease pump
13	Grease cartridge	07950-90403	(Lithium base grease: 400 g)
14	Nipple	424-98-11110	For hydraulic oil drain
15	Hose	424-98-11120	
16	Hammer	09039-00150	
17	Plate	09963-03000	Warning tag

If any of the above tools are broken, please order them from your Komatsu distributor.

NOTICE

If small holes or thinner parts are found on element when it is checked with an electric bulb after cleaning and drying, replace the element.

When cleaning the element, do not hit it or beat it against anything.

Do not use element whose folds or gasket or seal are damaged.

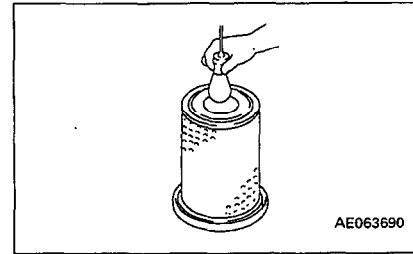

4. Install the cleaned element.

REPLACING INNER ELEMENT

1. First remove the outer element, and then remove the inner element.
2. To prevent dust from getting in, use a clean cloth or tape to cover the air connector (outlet side).
3. Clean the air cleaner body interior, then remove the cover installed in Step 2.
4. Fit a new inner element to the connector and tighten it with nuts. Do not clean and reinstall an inner element.
5. Install the outer element.

REMARK

When installing both the inner element and outer element, move the elements lightly while tightening the nut to bring the seal rubber at the tip of the element into tight contact with the inside of the body.

24.2.10 REPLACE BUCKET TEETH

⚠ WARNING

It is dangerous if the work equipment moves by mistake when the teeth are being replaced. Set the work equipment in a stable condition, then stop the engine, apply the parking brake and locks securely to the work equipment control levers.

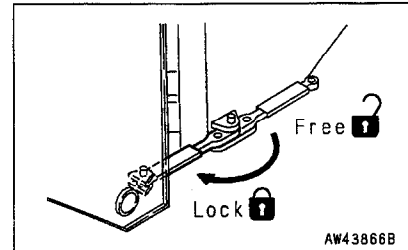
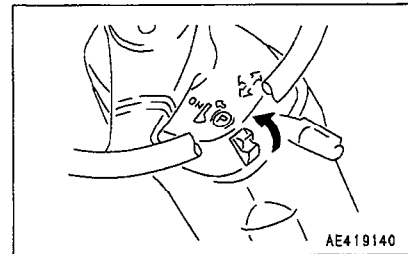

If the bucket equipped with tip tooth.

Replace the teeth before they wear down as far as the adaptor.

1. Extract pin ② fitted to the bucket and then remove tooth ①. When extracting pin ②, strike the part (either the left or right part) with a sharp object. This will enable the pin to be extracted from the opposite side.
2. Insert the new tooth ① into the adaptor ③, and insert pin ② partway as shown in the diagram. Then drive it home by means of a hammer.
3. After operating the machine for a few hours, check that the pin does not come out.

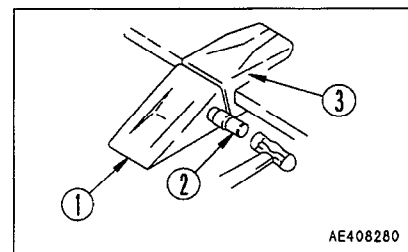
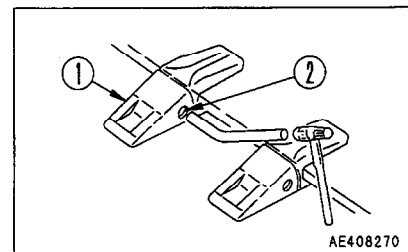

CHECK OF INFLATION PRESSURE OF TIRES AND INFLATION OF THEM

⚠ WARNING

When inflating a tire, check that no one will enter the working area and use an air chuck which has a clip and which can be fixed to the air valve.

- While inflating the tire, check the inflation pressure occasionally so that it will not rise too high.
- If the rim is not fitted normally, it may be broken and scattered while the tire is inflated. To ensure safety, place a guard around the tire and do not work in front of the rim but work on the tread side of the tire.
- Abnormal drop of inflation pressure and abnormal fitting of the rim indicate a trouble in the tire or rim. In this case, be sure to ask a tire repair shop to carry out repairs.
- Be sure to observe the specified inflation pressure.
- Do not adjust the inflation pressure of the tires just after high-speed travel or heavy-duty work.

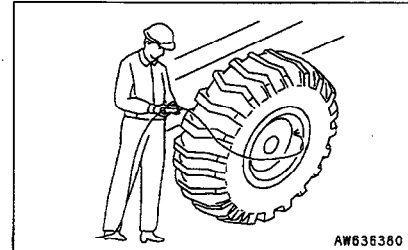

Check

Measure the inflation pressure with a tire pressure gauge while the tires are cool before starting work.

Inflation of tires

Adjust the inflation pressure properly.

When inflating a tire, use an air chuck which can be fixed to the air valve of the tire as shown in the figure. Do not work in front of the rim but work on the tread side of the tire.

The proper inflation pressure is shown below.

Tire size	Inflation pressure
40/65-39-36PR (L5) (standard)	0.44 MPa (4.5 kgf/cm ² , 63.9 PSI)
41.25/70-39-34PR(L5)(if equipped)	0.44 MPa (4.5 kgf/cm ² , 63.9 PSI)

NOTICE

The appropriate tire inflation pressure differs according to the type of work, so see "12.18 HANDLING THE TIRES".

24.2.20 DRAIN WATER FROM WATER SEPARATOR (IF EQUIPPED)

When float ② is at or above red line ①, drain the water according to the following procedure:

1. Loosen drain plug ③ and drain the accumulated water until the float reaches the bottom.
2. Tighten drain plug ③.
3. If the air is sucked into fuel line when drain the water, be sure to bleed air in the same manner as for the fuel filter.
See Fuel Filter Cartridge in "24.7 EVERY 500 HOURS SERVICE" section.

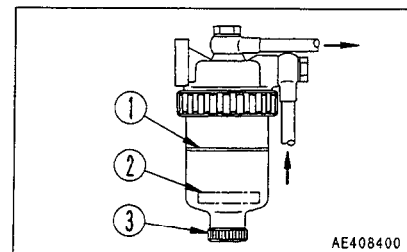

24. SERVICE PROCEDURE

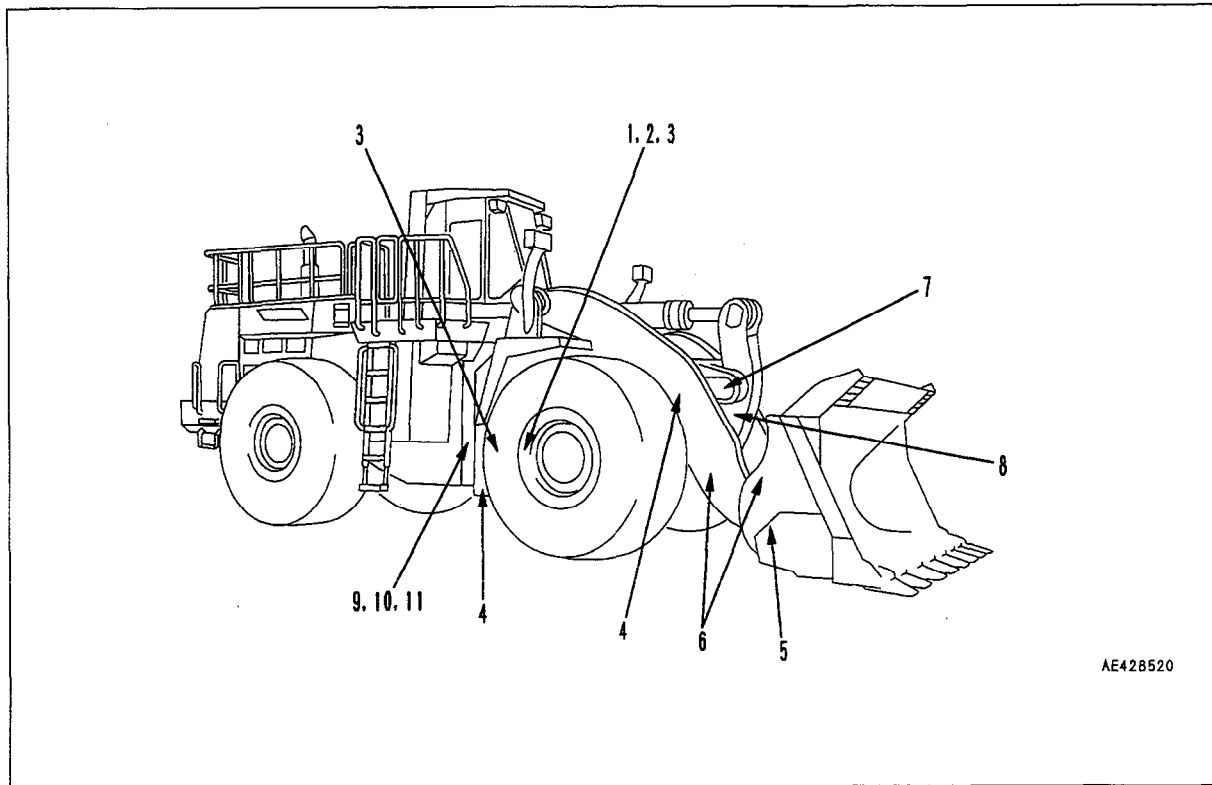

AE428520

- 1. Bucket cylinder bottom pin (1 point)
- 2. Lift arm hinge pin (2 points)

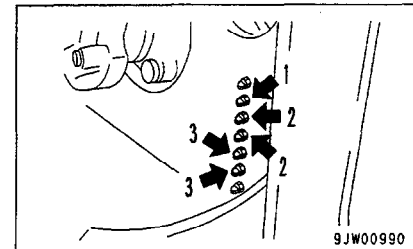

9JW00990

- 3. Steering cylinder pin (4 points)

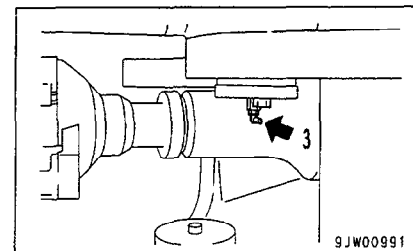

9JW00991

- 4. Lift cylinder pin (4 points)

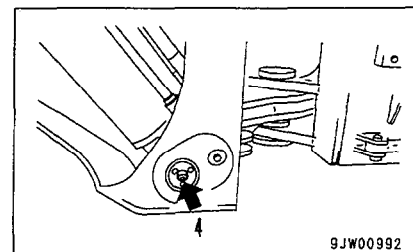

9JW00992

⚠ WARNING

When cranking the engine, confirm the safety around the engine, as the engine may start.

11. After replacing the filter cartridge, turn the key in the starting switch to the START position. When the engine starts, check for any leakage from the filter seal surface. If there is any leakage, check the tightening of the filter cartridge. If there is still any leakage, follow the procedure in Steps 2 and 5 to remove the filter cartridge, and check the packing surface. If there is any damage or any dirt or dust caught in the surface, replace the packing with a new part, then repeat Steps 6 to 10 to install again.

When the engine is started after it has run out of fuel, if the engine misfires or black smokes comes out, bleed the air from the fuel line as follows.

12. Loosen air bleed plug ⑤ of the injection pump, then repeat Steps 8 to 10 and operate the priming pump to bleed the air.

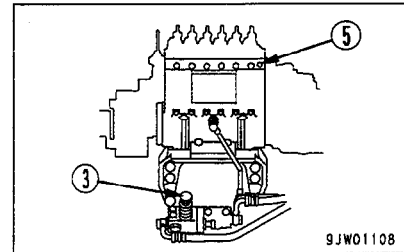

24.9 EVERY 2000 HOURS SERVICE

⚠ WARNING

Be sure to put a warning tag on work equipment control levers ①.

Maintenance for every 50, 100, 250, 500 and 1000 hours should be carried out at the same time.

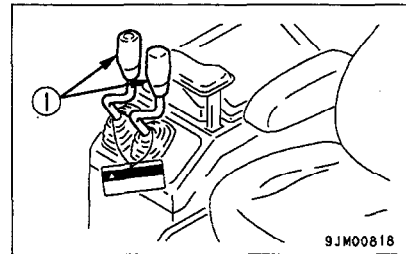

24.9.1 CHANGE OIL IN HYDRAULIC TANK, REPLACE HYDRAULIC FILTER ELEMENT

⚠ WARNING

The oil is at high temperature immediately after the machine has been operated. Wait for the oil to cool down before changing the oil. When removing the oil filler cap, turn it slowly to release the internal pressure, then remove it carefully.

Prepare the following.

- Container to catch drained oil: min. 490 l capacity
- Refill capacity: 490 l (129 US gal, 108 UK gal)

1. Lower the bucket horizontally to the ground and apply the parking brake, then stop the engine.
2. Remove the bolt, then remove the cover.
3. Remove the cap of oil filler (F) and air bleed plug (1) on filter case.

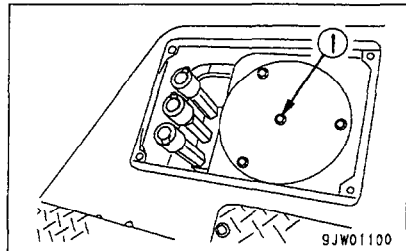
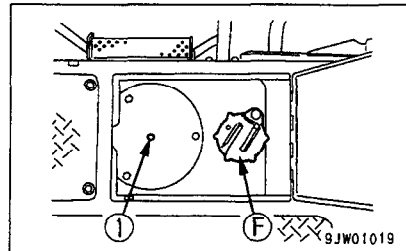
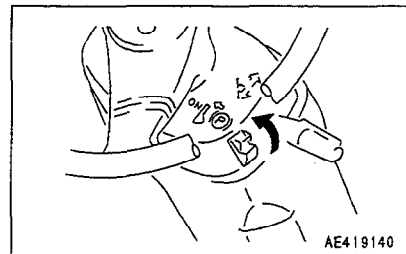

4. Set a container to catch the oil under drain plug ②.
5. Remove drain plug ②.
6. Loosen drain valve ③, then gradually pull it out to drain the oil.
7. After draining the oil, close drain valve ③, then tighten drain plug ②.

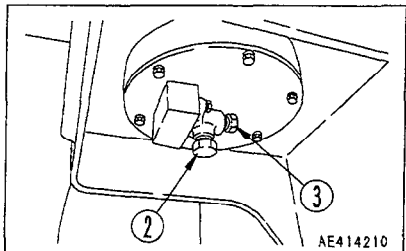

SPECIFICATIONS



29. HANDLING JOYSTICK STEERING SYSTEM

- 1) Change the transmission to the manual mode (ON/OFF) with the manual switch (push-button switch).
When the switch is pressed once, the pilot lamp lights up and the system is turned ON; when the switch is pressed again, the pilot lamp goes out and the system is switched OFF.

OFF: Automatic gear shifting
ON: Gear shifting using transmission control lever, or shift up or shift down switch (joystick steering machine only)

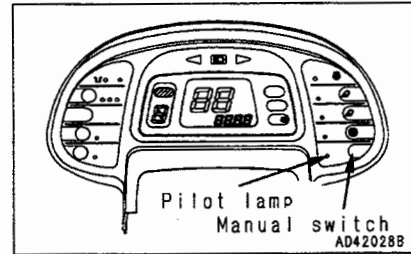

- 2) When the joystick steering is ON (operated with joystick lever), if the manual switch is turned ON, it is possible to shift the speed range between 1 and 4 with shift up switch ② or shift down switch ③ as shown in the table below.

Gear shift lever position	Shift range			
	1	2	3	4
Ⓐ 1st	○			
Ⓑ 2nd	○ ←→ ○			
Ⓒ 3rd	○ ←→ ○ ←→ ○			
Ⓓ 4th	○ ←→ ○ ←→ ○ ←→ ○			

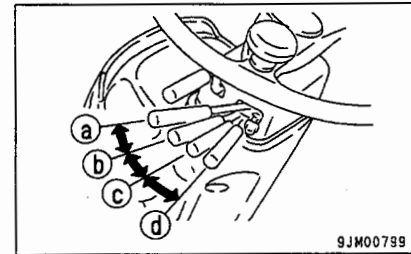
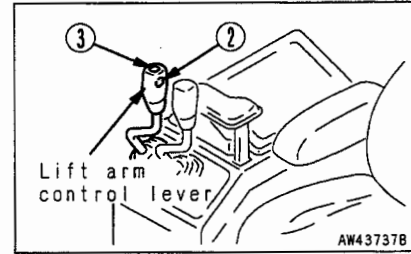

When the gear shift lever is at the 2nd or 3rd position, if the speed range is shifted from the 2nd to the 1st with shift down switch and the travel direction is changed between FORWARD and REVERSE, the speed range is shifted up from the 1st to the 2nd automatically.

- The combination of functions for switches ② and ③ is as shown in the table below.

Function	Steering Transmission Lift arm control lever switch	Steering wheel		Joystick		
		Auto- matic	Manual	Automatic		Manual
				Manual switch OFF	Manual switch ON	
②		Hold	-	Hold	Shift up	Shift up
③		Kick down	Kick down (Only from 2nd)	Kick down	Shift down	Shift down

The auto mode of the transmission is effective only when the vehicle is equipped with the automatic shift function (if equipped).

30. MAIN MONITOR FAILURE DISPLAY

JOYSTICK CONTROL SYSTEM

(Including joystick unit and machine body harness system)

Error Code	Item	Problem system	
		Short circuit	Disconnection
56	Joystick caution relay	○	(*1)
57	Steering R (right) Sol (Detected when power is output)	○	○
58	Steering L (left) Sol (Detected when power is output)	○	○
59	Steering R (right) short circuit at Sol HOT end	○	X
60	Steering L (left) short circuit at Sol HOT end	○	X
61	Steering Sol cut relay	○	○
62 in	Abnormality in joystick neutral switch	○	○
63 in	Abnormality in joystick potentiometer	○	○

If a trouble is detected, the joystick caution system operates.

(*1) : Since E56 is kept turned ON, breakage of its wire cannot be judged actually.

- Since E59 and E60 cannot be distinguished from each other for the reason of design of the hardware, the alarms for them are turned on simultaneously.

ELECTRONIC GOVERNOR CONTROL SYSTEM

Error Code	Item
90	Abnormality inside controller
91	Abnormality governor servo system
92	Abnormality rack sensor system
93	Abnormality No. 1 Ne sensor system
94	Abnormality No. 2 Ne sensor system
95	Abnormality water temperature sensor system
97	Abnormality acceleration sensor system
99	Abnormality engine overrun

CLICK HERE TO **DOWNLOAD** THE COMPLETE MANUAL

- Thank you very much for reading the preview of the manual.
- You can download the complete manual from: www.heydownloads.com by clicking the link below



- Please note: If there is no response to CLICKING the link, please download this PDF first and then click on it.

CLICK HERE TO **DOWNLOAD** THE COMPLETE MANUAL