

Operation & Maintenance Manual

WHEEL LOADER

WA600-6

SERIAL NUMBERS 60361 and up

ecot3

⚠ WARNING

Unsafe use of this machine may cause serious injury or death. Operators and maintenance personnel must read this manual before operating or maintaining this machine. This manual should be kept near the machine for reference and periodically reviewed by all personnel who will come into contact with it.

NOTICE

Komatsu has Operation & Maintenance Manuals written in some other languages. If a foreign language manual is necessary, contact your local distributor for availability.

KOMATSU

CLICK HERE TO **DOWNLOAD** THE COMPLETE MANUAL

- Thank you very much for reading the preview of the manual.
- You can download the complete manual from: www.heydownloads.com by clicking the link below



- Please note: If there is no response to CLICKING the link, please download this PDF first and then click on it.

CLICK HERE TO **DOWNLOAD** THE COMPLETE MANUAL

POSITION OF SERVICE METER

The service meter is displayed on the character display at the bottom center of the machine monitor.

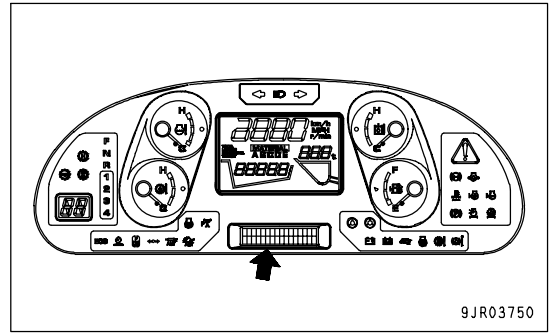

TABLE TO ENTER SERIAL NO. AND DISTRIBUTOR

Machine serial No.	
Engine serial No.	
Product identification number (PIN)	
Distributor name	
Address	-----

Service Personnel	-----
Phone/Fax	

SAFETY LABELS

The following safety labels are used on this machine. Be sure that you fully understand the correct position and content of these safety labels.

To ensure that the content of these safety labels can be read properly, be sure that they are in the correct place and always keep them clean. When cleaning them, use soap and water. Do not use organic solvents or gasoline. These may cause the safety labels to peel off.

If the safety labels are damaged or lost, or cannot be read, replace them with new parts. For details of the part numbers, see this manual or check on the actual part, and order the new part from your Komatsu distributor.

There are also other labels in addition to the safety labels. Handle these labels in the same way.

KEEP MACHINE CLEAN

- If you get on or off the machine or carry out inspection and maintenance when the machine is dirty with mud or oil, there is a hazard that you will slip and fall. Wipe off any mud or oil from the machine. Always keep the machine clean.
- If water gets into the electrical system, there is a hazard that it will cause malfunctions or misoperation. If there is any misoperation, there is danger that the machine may move unexpectedly and cause serious personal injury or death. When washing the machine with water or steam, do not allow the water or steam to come into direct contact with electrical components.

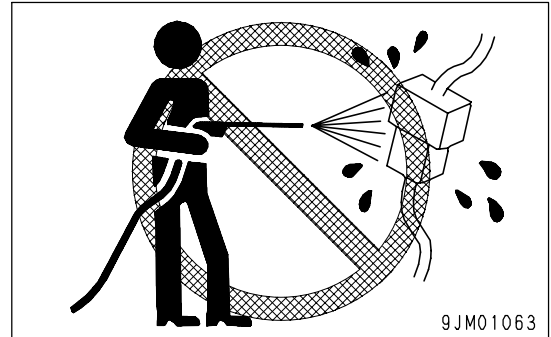
**PRECAUTIONS INSIDE OPERATOR'S COMPARTMENT**

- When entering the operator's compartment, always remove all mud and oil from the soles of your shoes. If you operate the pedal with mud or oil affixed to your shoes, your foot may slip and this may cause a serious accident.
- Do not leave tools or a machine parts lying around inside the operator's compartment. If tools or parts get into the control devices, it may obstruct operation and cause the machine to move unexpectedly, resulting in serious personal injury or death.
- Do not stick suction pads to the window glass. Suction pads act as a lens and may cause fire.
- Do not use a cell phone when driving or operating the machine. This may lead to mistakes in operation, which could cause serious personal injury or death.
- Never bring any dangerous objects such as flammable or explosive items into the operator's compartment.

PROVIDE FIRE EXTINGUISHER AND FIRST AID KIT

Always follow the precautions below to prepare for action if any injury or fire should occur.

- Be sure that fire extinguishers have been provided and read the labels to ensure that you know how to use them in emergencies.
- Carry out periodic inspection and maintenance to ensure that the fire extinguisher can always be used.
- Provide a first aid kit in the storage point. Carry out periodic checks and add to the contents if necessary.

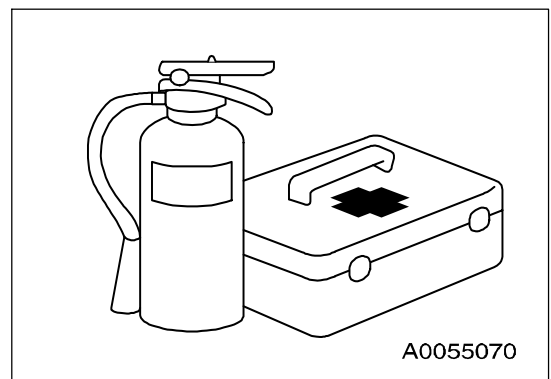
**IF ANY PROBLEM IS FOUND**

If you find any problems in the machine during operation or maintenance (noise, vibration, smell, incorrect gauges, smoke, oil leakage, etc., or any abnormal display on the warning devices or monitor), report to the person in charge and have the necessary action taken. Do not operate the machine until the problem has been corrected.

INSPECTION AND MAINTENANCE BEFORE STARTING ENGINE

Carry out the following checks before starting the engine at the beginning of the day's work to ensure that there is no problem with the operation of the machine. If this inspection is not carried out properly problems may occur with the operation of the machine, and there is danger that this may lead to serious personal injury or death.

- Remove all dirt from the surface of the window glass to ensure a good view.
- "WALK-AROUND CHECK (PAGE 3-118)" is surely executed.
- Remove all dirt from the surface of the lens of the front lamps, working lamps, and rear combination lamp, and check that they light up correctly.
- Check the coolant level, fuel level, and oil level in engine oil pan, check for clogging of the air cleaner, and check for damage to the electric wiring.
- Check that there is no mud or dust accumulated around the movable parts of the accelerator pedal or brake pedal, and check that the pedals work properly.
- Adjust the operator's seat to a position where it is easy to carry out operations, and check that there is no damage or wear to the seat belt or mounting clamps.
- Check that the gauges work properly, check the angle of the mirror, and check that the control levers are all at the Neutral position.
- Before starting up the engine, check that the work equipment lock lever is in the LOCK position.
- Adjust the mirrors so that the rear of the machine can be seen clearly from the operator's seat. See "ADJUSTING MIRRORS (PAGE 3-133)".
- Check that there are no persons or obstacles above, below, or in the area around the machine.
- Check that the parking brake switch is at the ON position.
- Check that frame lock lever (1) is securely fixed at FREE position(F).

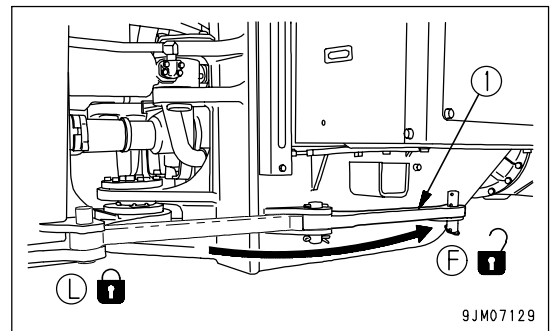
**PRECAUTIONS WHEN STARTING ENGINE**

- Start and operate the machine only while seated.
- When starting the engine, sound the horn as a warning.
- Do not allow anyone apart from the operator to ride on the machine.
- Do not attempt to start the engine by short-circuiting the engine starting circuit. This may cause fire, serious personal injury or death.
- Check that the backup alarm (alarm buzzer when machine travels in reverse) works properly.

PRECAUTIONS IN COLD AREAS

- Carry out the warming-up operation thoroughly. If the machine is not thoroughly warmed up before the control levers are operated, the reaction of the machine will be slow, and this may lead to unexpected accidents.
- If the battery electrolyte is frozen, do not charge the battery or start the engine with a different power source. There is a hazard that this will ignite the battery and cause the battery to explode. Before charging or starting the engine with a different power source, melt the battery electrolyte and check that there is no leakage of electrolyte before starting.

TOWING

PRECAUTIONS WHEN TOWING

Always use the correct towing equipment and towing method. Any mistake in the selection of the wire rope or towing bar or in the method of towing a disabled machine may lead to serious personal injury or death.

For details of the procedure for towing, see the "METHOD OF TOWING MACHINE (PAGE 3-201)"

- Always confirm that the wire rope or drawbar used for towing has ample strength for the weight of the machine being towed.
- Never use a wire rope which has cut strands (A), reduced diameter (B), or kinks (C). There is danger that the rope may break during the towing operation.
- Always wear leather gloves when handling wire rope.
- Never tow a machine on a slope.
- During the towing operation, never stand between the towing machine and the machine being towed.

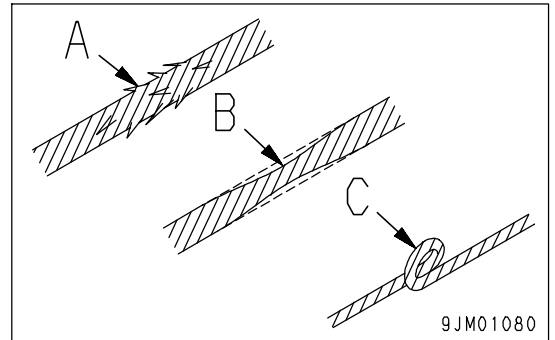

HANDLING ACCUMULATOR AND GAS SPRING

This machine is equipped with an accumulator. Even after the engine stops, the work equipment control levers can be operated for a short time in the LOWER direction to allow the work equipment to go down under its own weight. After stopping the engine, set the work equipment lock lever and steering lock lever to the LOCK position and turn the parking brake switch ON.

The accumulator and gas spring are charged with high-pressure nitrogen gas. If the accumulator is handled mistakenly, it may cause an explosion that could lead to serious personal injury or death. For this reason, always observe the following precautions.

- Do not disassemble the accumulator.
- Do not bring it near flame or dispose of it in fire.
- Do not make holes in it, weld it, or use a cutting torch.
- Do not hit or roll the accumulator, or subject it to any impact.
- When disposing of the accumulator, the gas must be released. Please contact your Komatsu distributor to have this work performed.

**PRECAUTIONS WITH COMPRESSED AIR**

- When carrying out cleaning with compressed air, there is a hazard of serious personal injury caused by flying dust or particles.
- When using compressed air to clean the filter element or radiator, wear safety glasses, anti-dust mask, gloves, and other protective equipment.

MAINTENANCE OF AIR CONDITIONER

If air conditioner refrigerant gets into your eyes, it may cause loss of sight; if it contacts your skin, it may cause frostbite. Never loosen any parts of the cooling circuit.

DISPOSING OF WASTE MATERIALS

To prevent pollution, pay careful attention to the method of disposing of waste materials.

- Always put oil drained from your machine in containers. Never drain oil directly onto the ground or dump into the sewage system, rivers, the sea, or lakes.
- Obey appropriate laws and regulations when disposing of harmful objects such as oil, fuel, coolant, solvent, filters, and batteries.

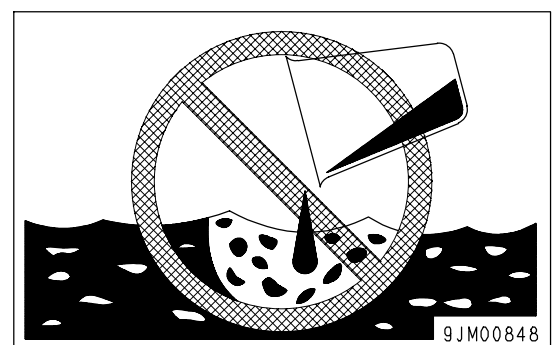
**METHOD OF SELECTING WINDOW WASHER FLUID**

Use an ethyl alcohol base washer liquid.

Methyl alcohol base washer liquid may irritate your eyes, so do not use it.

Machine monitor

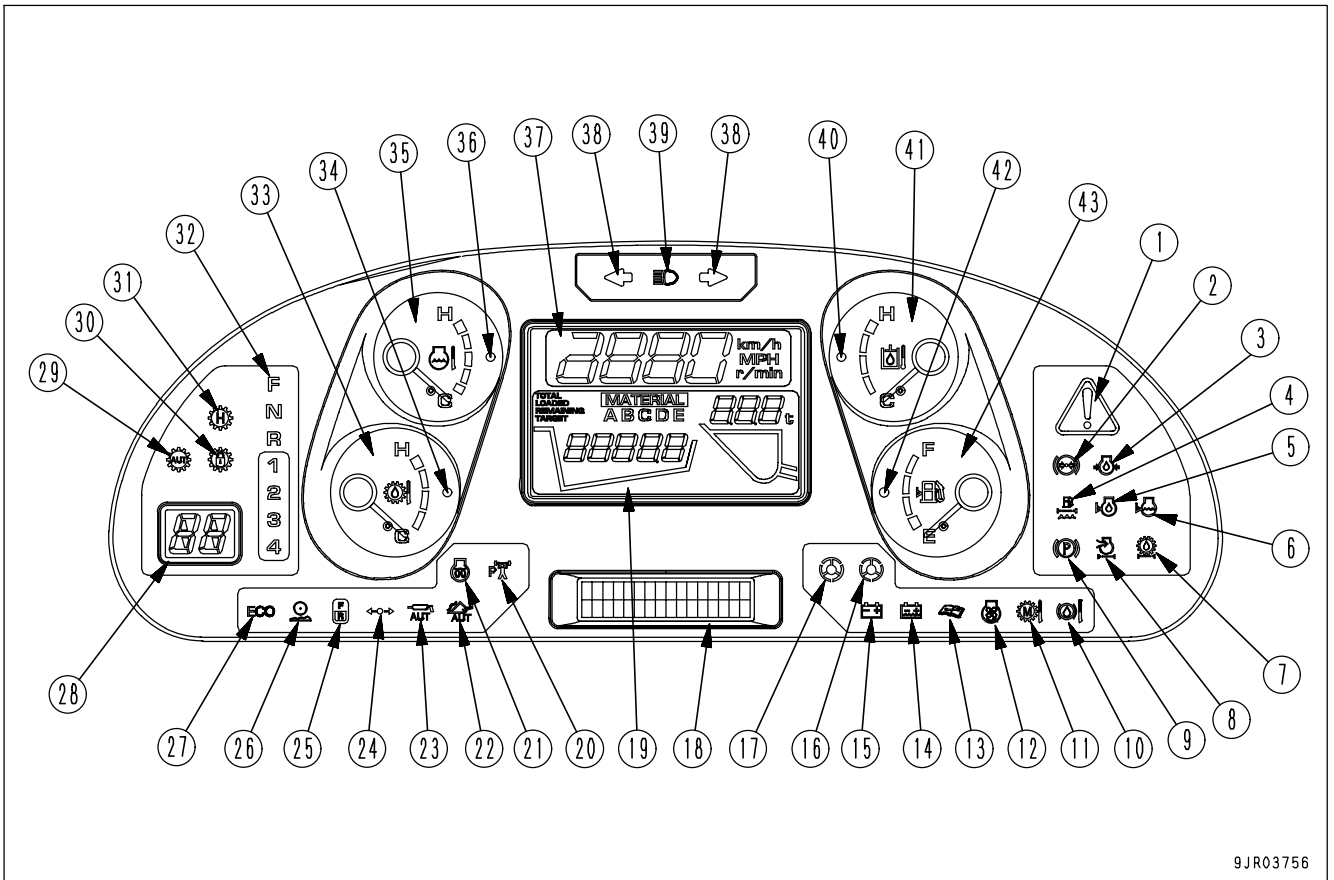

9JR03756

REMARK

See the section below for details of the procedure for replacing the filter and oil.

- Engine oil
"CHANGE OIL IN ENGINE OIL PAN, REPLACE ENGINE OIL FILTER CARTRIDGE (PAGE 4-64)"
- Engine oil filter
"CHANGE OIL IN ENGINE OIL PAN, REPLACE ENGINE OIL FILTER CARTRIDGE (PAGE 4-64)"
- Fuel pre-filter
"REPLACE FUEL PRE-FILTER CARTRIDGE (PAGE 4-66)"
- Transmission oil filter
"REPLACE TRANSMISSION OIL FILTER ELEMENT (PAGE 4-69)"
- Fuel main filter
"REPLACE FUEL MAIN FILTER CARTRIDGE (PAGE 4-68)"
- Transmission oil
"CHANGE OIL IN TRANSMISSION CASE, CLEAN STRAINER (PAGE 4-72)"
- Corrosion resistor
"REPLACE CORROSION RESISTOR CARTRIDGE (PAGE 4-75)"
- Hydraulic tank breather element
"REPLACE HYDRAULIC TANK BREATHER ELEMENT (PAGE 4-80)"
- Hydraulic filter
"CHANGE OIL IN HYDRAULIC TANK, REPLACE HYDRAULIC FILTER ELEMENT (PAGE 4-77)"
- Hydraulic oil
"CHANGE OIL IN HYDRAULIC TANK, REPLACE HYDRAULIC FILTER ELEMENT (PAGE 4-77)"
- Axle oil
"CHANGE AXLE OIL (PAGE 4-81)"

ENGINE SPEED (OR TRAVEL SPEED) DISPLAY

When the machine monitor meter displays the travel speed, this display (6) shows the engine speed. When the machine monitor meter displays the engine speed, this display (6) shows the travel speed.

For details, see "METHOD OF SWITCHING TRAVEL SPEED/ENGINE SPEED DISPLAY/NON-DISPLAY (PAGE 3-49)".

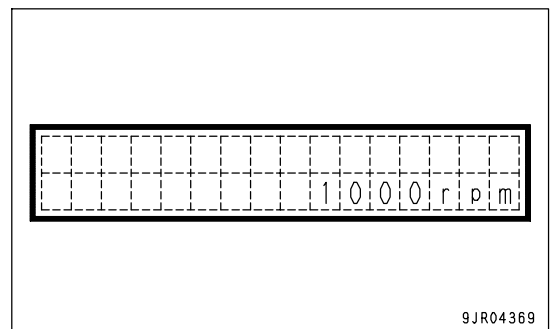

9JR04369

TRANSMISSION OIL FILTER CLOGGING CAUTION LAMP

This lamp (7) lights up when the transmission oil filter is clogged. When the transmission oil filter is clogged, the transmission clogging caution lamp lights up. At the same time, "E01 TRANSM FILTER" is displayed, so stop the engine, and replace the element.

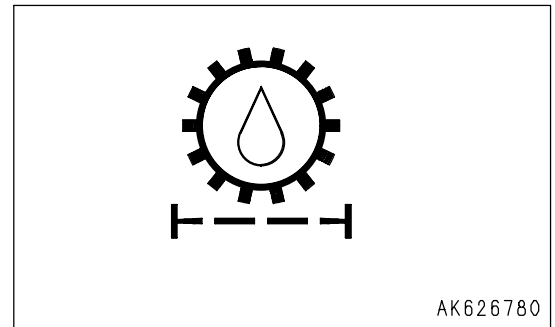
**REMARK**

If the engine is stopped or the torque converter oil temperature is low, the transmission oil filter clogging caution lamp does not light up.

METHOD OF DISPLAYING ODOMETER

Use this when checking the total distance that the machine has traveled.

1. Check that the character display is displaying the service meter or an action code. If there is any other display, turn the starting switch OFF, then turn the starting switch ON again and wait for the service meter display or action code display to appear.
2. Press the (◇) portion of the machine monitor mode selector switch 1 to display "ODO" (odometer).

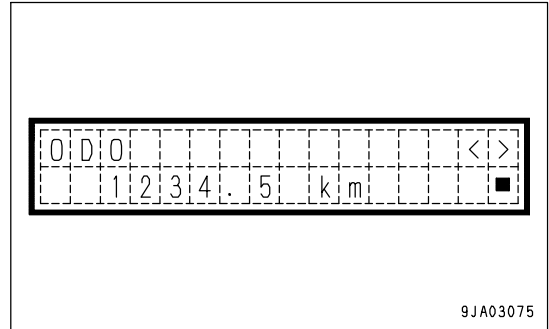

REMARK

If a load meter is installed, when the (◇) portion of the machine monitor mode selector switch 1 is pressed, the screen displays "LOAD METER".

If the (>) or (<) portion of the machine monitor mode selector switch 2 is then pressed, the display changes to "ODO" (odometer).

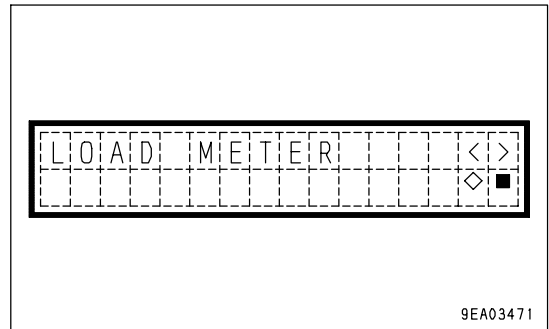

3. After checking the screen, press the (■) portion of the machine monitor mode selector switch 1 or turn the starting switch OFF.

4. Press the (◇) portion of the machine monitor mode selector switch 1.
 The top line displays "ADJUST 23:59".
 The bottom line displays "2000/01/01".

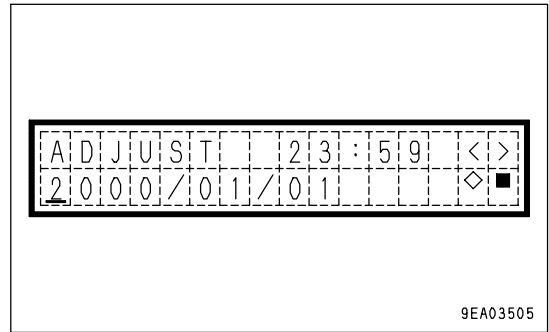

REMARK

Once the time is input, the clock will show the correct time from that time on.

5. Input the time.
 The cursor is displayed in turn at the input position for the date and time. Press the (>) or (<) portion of the machine monitor mode selector switch 2 to input "0 - 9".
6. After selecting the input value, press the (◇) portion of the machine monitor mode selector switch 1. The input value is accepted and the cursor moves to the next input position.
 Repeat Steps 5 and 6 to input and select the numbers from the year to the minute.

7. At the last digit for the minute units, press the (◇) portion of the machine monitor mode selector switch 1. The input values are accepted and the display portion of the character display returns to the service meter and clock display on the standard screen.

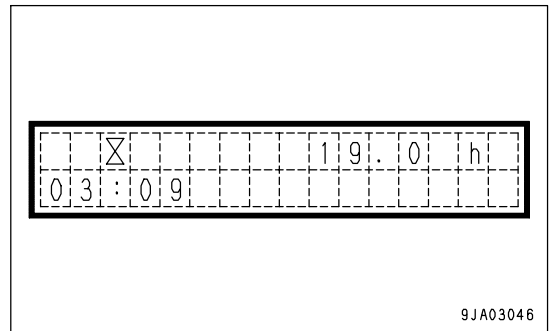

8. If the wrong number is input or the input operation is to be aborted, press the (■) portion of the machine monitor mode selector switch 1. The screen returns to the previous screen.

EMERGENCY PARKING BRAKE CANCEL SWITCH

! WARNING

When the emergency parking brake cancel switch is released, the machine may move.

When releasing the emergency parking brake switch, see "METHOD OF RELEASING BRAKE BY USING EMERGENCY PARKING BRAKE CANCEL SWITCH (PAGE 3-203)".

If the engine will not start for some reason, use this switch (16) to release the parking brake. Please contact your Komatsu distributor to have the brake released.

Position (a): Release

Position (b): Normal position

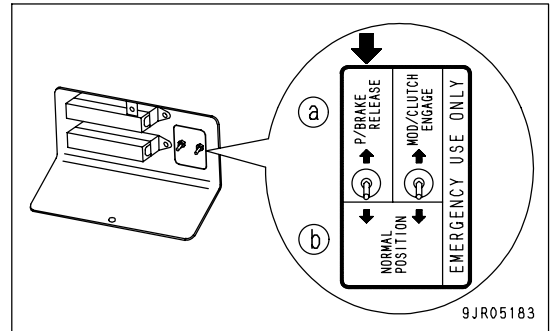

EMERGENCY MODULATION CLUTCH DIRECT CONNECTION SWITCH

If the modulation clutch will not engage for some reason and the machine cannot travel, use this switch (17) to engage the clutch as an emergency measure.

Please contact your Komatsu distributor to have the clutch engaged.

Position (a): Engaged

Position (b): Normal position

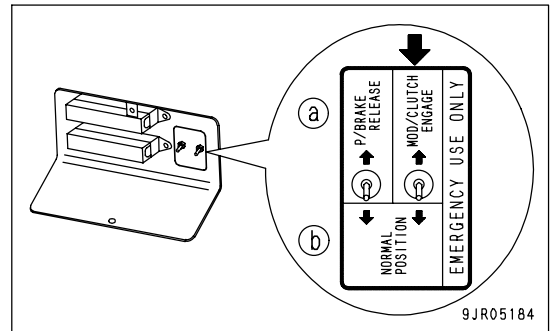

TORQUE CONVERTER LOCK-UP SWITCH

WARNING

When traveling down slopes of a grade of more than 6°, never depress the accelerator pedal fully, regardless of whether the torque converter lock-up switch is ON or OFF. It is extremely dangerous to drive too fast.

NOTICE

To prevent overrun when the machine next travels at high speed, do not shift down.

- When traveling in F3 at a speed of 17 km/h (10.6 MPH) or more, do not shift down to F2.
- When traveling in F4 at a speed of 30 km/h (18.6 MPH) or more, do not shift down to F3.

If the transmission is shifted down under the above conditions, the overrun prevention function is actuated and the speed range is maintained until the travel speed is reduced to the condition for shifting gear.

When the actual travel speed range is 2nd - 4th in both forward and reverse, the torque converter lock-up function is actuated according to the travel speed and the transmission changes to direct drive.

Use this switch (13) to operate the torque converter lock-up function.

Position (a): ON

The pilot lamp inside the switch lights up and the lock-up is actuated according to the travel speed. When the lock-up is in use, the lock-up pilot lamp on the machine monitor lights up.

Position (b): OFF

Press this to cancel the lock-up. The lock-up is cancelled.

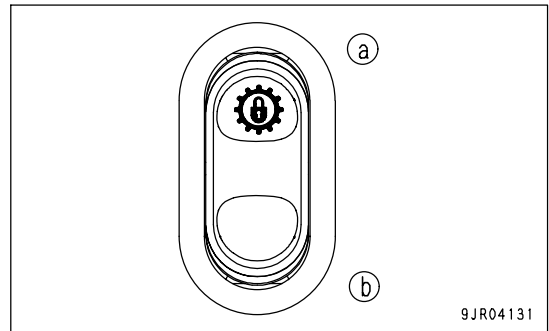
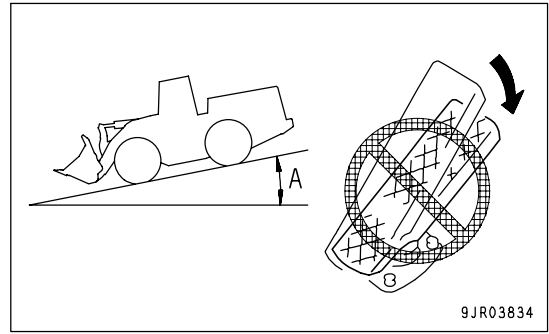

REMARK

- The torque converter lock-up function makes it possible to improve the efficiency of power transmission when traveling at high speed and also reduces the fuel consumption.
- When traveling downhill and using the braking force of the engine, actuate the torque converter lock-up.

LEFT BRAKE PEDAL

This actuates the wheel brakes.

If the left brake pedal is depressed, the brakes are applied and the driving force is reduced.

REMARK

- Use the brakes and accelerator together to reduce the speed or stop the machine. Use the left brake when operating the work equipment.
- When the left brake is depressed, the modulation clutch slips and the friction causes the temperature to rise.

If the accelerator pedal is kept pressed or the engine speed remains raised because of the RPM setting, if you put your foot on the left brake pedal and continue operations with the pedal slightly depressed (approx. 3° or more), the modulation clutch temperature caution lamp may light up.

If this condition is continued, the central warning lamp will light up and the alarm buzzer will sound intermittently. If this happens, stop the machine, run the engine at a mid-range speed under no load, and wait for the lamp to go out.

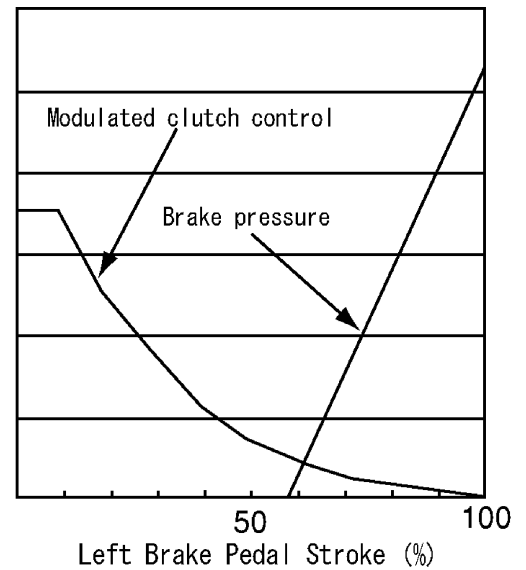

AJSS LEVER FRONT-REAR ADJUSTMENT KNOB

 **WARNING**

Carry out front-rear of adjustment of the AJSS lever with the machine is stopped. If the machine is moving and the lever is operated (adjusted), it may lead to serious personal injury.

Pull up this lever (3). It is possible to move the AJSS lever within a range (a) to the front and rear of 160 mm (6.3 in) (16 mm (0.6 in) x 10 stages).

In addition, when getting on or off the machine, it is also possible to move the AJSS lever 150 mm (5.9 in) to the rear. (range (b))

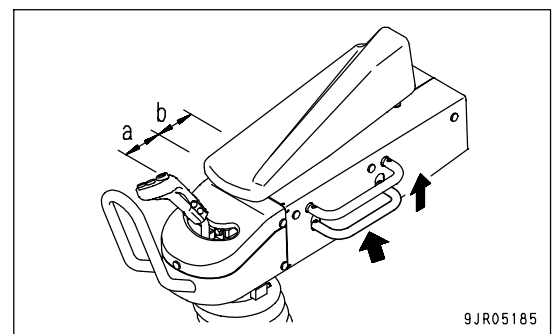

CAB LEFT DOOR OPEN KNOB

Pull open knob (1) to open the left door fully.

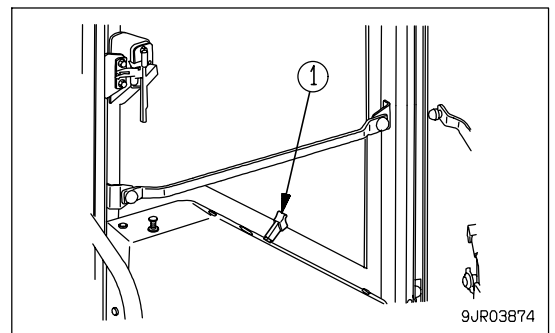
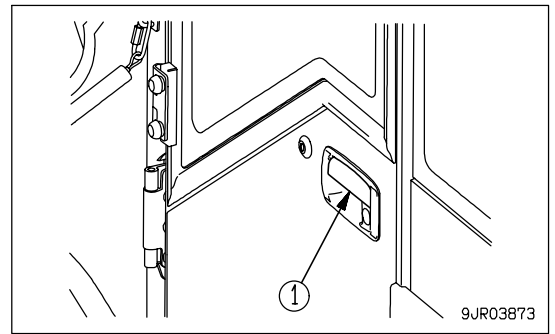

If the doorknob is pulled, the gas damper opens the door to the open position.

NOTICE

The gas damper is not a lock device to keep the cab door open.
Do not travel or carry out operations with the cab door left open.

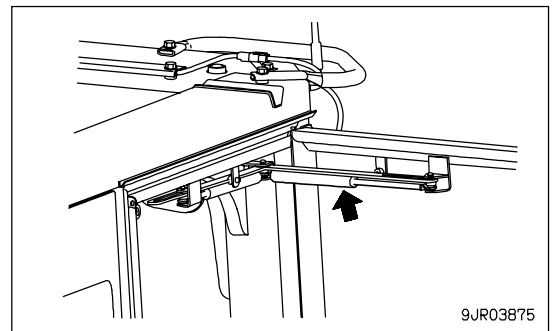

OPEN LOCK CANCEL KNOB FOR LEFT CAB WINDOW

Use this when you want to open the window in the left door.

When opening the window, press lock release knob (1) in the direction of the arrow until it stops to hold the window in position.
If the door is opened or closed without securing the window in position, the shock may cause the window to close.

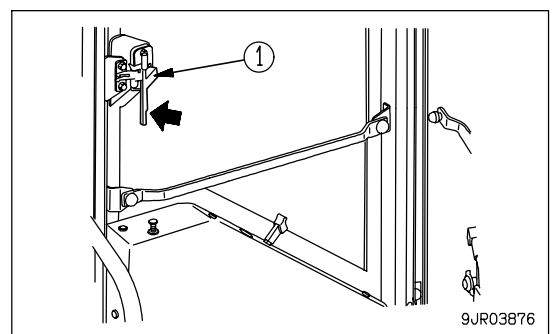

TAPE EJECT BUTTON

This button (7) is used to stop the tape and to eject the cassette. When this button is pressed, the tape is ejected and the radio plays.

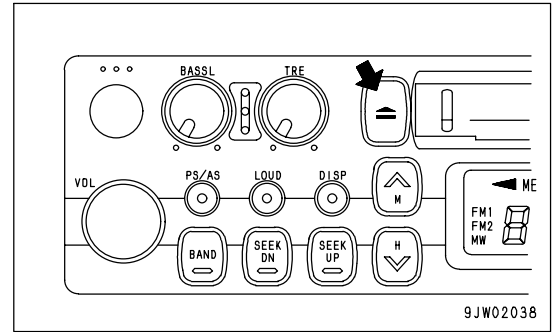

CASSETTE DOOR

Set the cassette with the exposed portion of the tape on the right side and insert it through the cassette door (8).

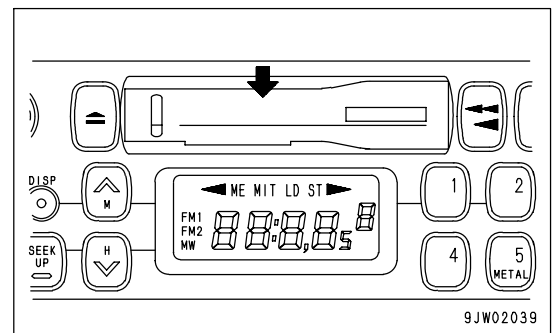

FAST-FORWARD, REWIND BUTTONS

These buttons (9) are used to fast-forward or rewind the tape.

- Fast-forward/rewind

If you press the button pointing in the same direction as the lighted arrow indicating the direction of play, the tape will be fast-forwarded; if you press the button pointing in the opposite direction, the tape will rewind.

To stop the tape, lightly press the button that is not locked. The fast-forward or rewind operation will be canceled.

If the fast-forward and rewind buttons are pressed at the same time, the tape will change sides.

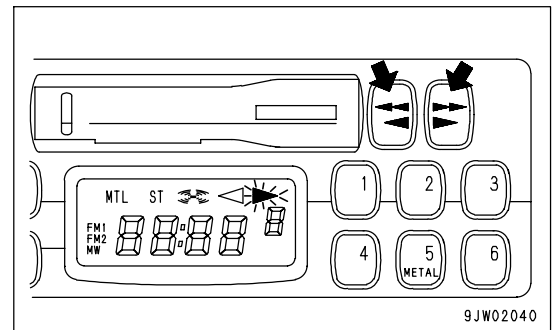

PRESET BUTTONS

These buttons (10) are used to call up the broadcast station frequencies preset in memory for each of buttons No. 1 to No. 6. It is possible to preset 18 stations (FM: 12; AM: 6) with these buttons.

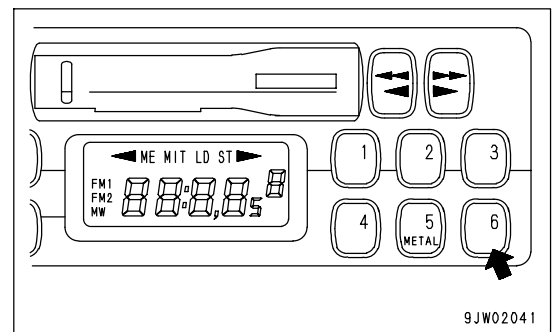

AIR CONDITIONER SWITCH

Use this switch (8) to operate or stop the air conditioner (cooling, dehumidifying warming).

- When the fan is actuated (display (b) is shown) and air conditioner switch (8) is pressed, the air conditioner is switched ON, lamp above the air conditioner switch lights up, and the air conditioner starts.

When switch (8) is pressed again, the air conditioner is switched OFF, lamp above the air conditioner switch goes out, and the air conditioner stops.

- Air conditioner cannot be operated while the fan is off.

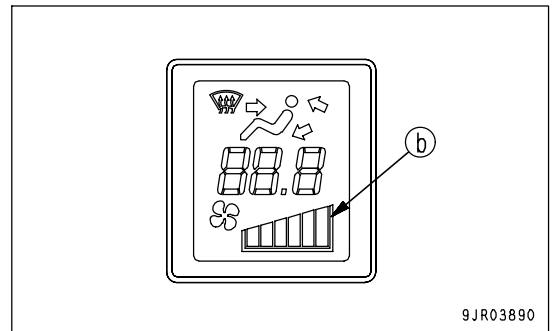
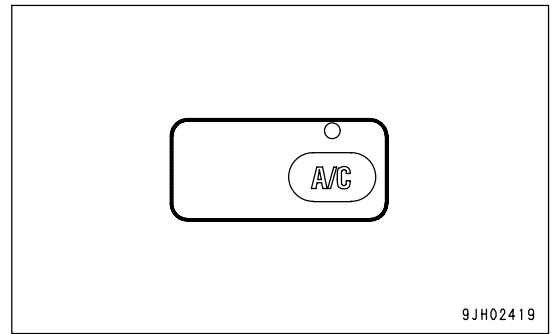

FUNCTION TO SWITCH SET TEMPERATURE DISPLAY BETWEEN FAHRENHEIT AND CELSIUS

It is possible to switch the set temperature display between °F and °C.

If the "∨" and "∧" portions of temperature setting switch (3) are pressed at the same time for more than 5 seconds while the fan is running, the temperature display will switch between °F and °C.

(Note that the unit is not displayed.)

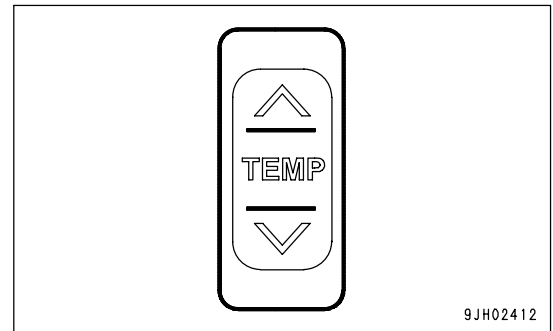

	Liquid crystal display range
°C	18.0 to 32.0
°F	63 to 91

CHECK ELECTRIC WIRING**WARNING**

- If the fuses frequently blow or if there are traces of short circuits in the electrical wiring, locate the cause and immediately perform repairs, or contact your Komatsu distributor for repairs.
- Keep the top surface of the battery clean and check the breather hole in the battery cap. If it is clogged with dirt or dust, wash the battery cap to clean the breather hole.

Check for damage, wrong fuse capacity, and any sign of disconnection or short circuit in the electric wiring. Also, check and tighten any loose terminals.

Particularly, check the wiring of the "battery", "starting motor" and "alternator" carefully.

When checking around the battery, make sure there is no accumulation of flammable material. Remove all flammable material.

Please contact your Komatsu distributor for investigation and correction of the cause.

CHECK PARKING BRAKE

Check that the parking brake works with full effect.

If there is any problem in the operation of the parking brake, please ask your Komatsu distributor to carry out adjustment.

CHECK BRAKE PEDAL

Drive the machine forward and check the effect of the brakes.

If there is any problem in the actuation of the brakes, please contact your Komatsu distributor to have the brakes adjusted.

CHECK INFLATION PRESSURE OF TIRES

Measure the inflation pressure with a tire pressure gauge, while the tires are cool, before starting work.

Check for damage or wear to the tires and the rims.

Check for loose wheel hub nuts (bolts).

The proper inflation pressure is shown below.

Size	Standard inflation pressure
35/65-33-36PR (Standard)	Front tire: 0.525MPa {5.4kg/cm ² , 76.7PSI} Rear tire: 0.525MPa {5.4kg/cm ² , 76.7PSI}
35/65-33-42PR (if equipped)	Front tire: 0.625MPa {6.4kg/cm ² , 90.9PSI} Rear tire: 0.625MPa {6.4kg/cm ² , 90.9PSI}
35/65R33 ☆ (if equipped)	Front tire: 0.59MPa {6.0kg/cm ² , 85.2PSI} Rear tire: 0.49MPa {5.0kg/cm ² , 71.0PSI}
35/65R33 ☆ ☆ (if equipped)	Front tire: 0.75MPa {7.6kg/cm ² , 108.0PSI} Rear tire: 0.65MPa {6.6kg/cm ² , 93.7PSI}

NOTICE

The optimum inflation pressure differs according to the type of work. For details, see "HANDLING THE TIRES (PAGE 3-187)".

3. After the pre-heating pilot lamp (2) goes out, turn the key of starting switch (1) to the START position to start the engine.

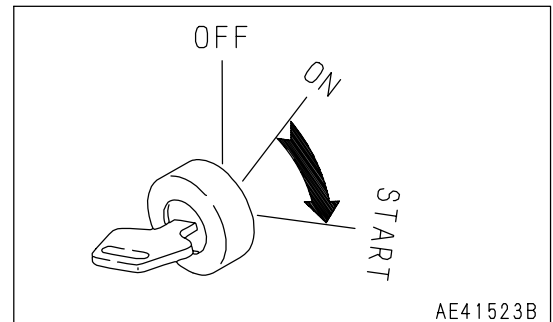

4. After the engine starts, release the key in starting switch (1). The key will automatically return to the ON position.

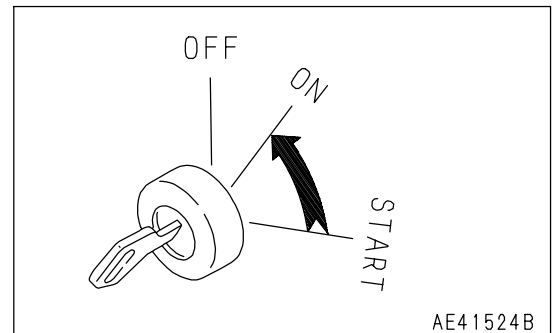

5. Immediately after starting the engine, run the engine at idling without depressing accelerator pedal (3) for at least 10 seconds in warm weather and for at least 15 seconds in cold weather.

REMARK

- Immediately after the engine starts, the turbocharger protect function prevents the engine speed from going above 1000 rpm for a maximum of 20 seconds, even if the accelerator pedal is depressed.
- If the accelerator pedal is kept depressed, the engine speed will suddenly rise after the turbo protect time. To prevent this, release the accelerator pedal.
- The turbocharger rotates at extremely high speed. Immediately after the engine is started, the pressure of the lubricating oil has not risen sufficiently, so if the engine speed is suddenly raised, it may lead to damage or seizure of the turbocharger bearing. The turbo protect function acts to prevent this problem. It uses electronic control to prevent the engine speed from rising above a certain speed for the first few seconds after the engine started.

AUTOMATIC WARMING-UP OPERATION

A function of engine warming-up run (engine rpm: 1000 rpm) is automatically actuated after the engine is started up, when the engine water temperature is low (below 30°C (86°F)). It is gradually released either when the engine water temperature rises over 30°C (86°F), or when 10 minutes have passed since the engine start-up.

AUTO SHIFT (SHIFT POSITION SPEED RANGE: OTHER THAN 1ST) AND MANUAL SHIFT 2ND, 3RD, 4TH

Gear speed before changing between FORWARD and REVERSE	Gear speed after changing between FORWARD and REVERSE
F2	R3 or R4
F3	R3 or R4
F4	R3 or R4
R2	F3 or F4
R3	F3 or F4
R4	F3 or F4

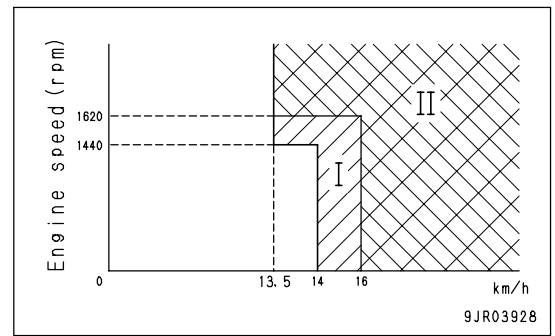

AUTO SHIFT (SHIFT POSITION SPEED RANGE: 1ST) AND MANUAL SHIFT 1ST

Gear speed before changing between FORWARD and REVERSE	Gear speed after changing between FORWARD and REVERSE
F1	R2 or R3 or R4
R1	F2 or F3 or F4

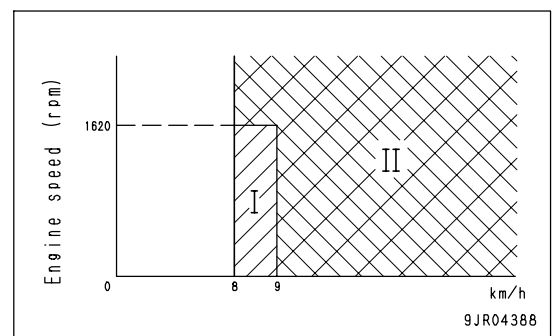

WORK POSSIBLE USING WHEEL LOADER

This section explains about general operations. Be sure to operate the machine correctly. For details, see "PRECAUTIONS WHEN HANDLING BLASTED ROCK (PAGE 3-164)".

In addition to the following, it is possible to further increase the range of applications by using various attachments.

RECOMMENDED COMBINATION OF SWITCHES FOR OPERATION

To improve fuel efficiency and to increase the service life of the machine, we recommend the combination of switches shown in the table below to match the operating conditions.

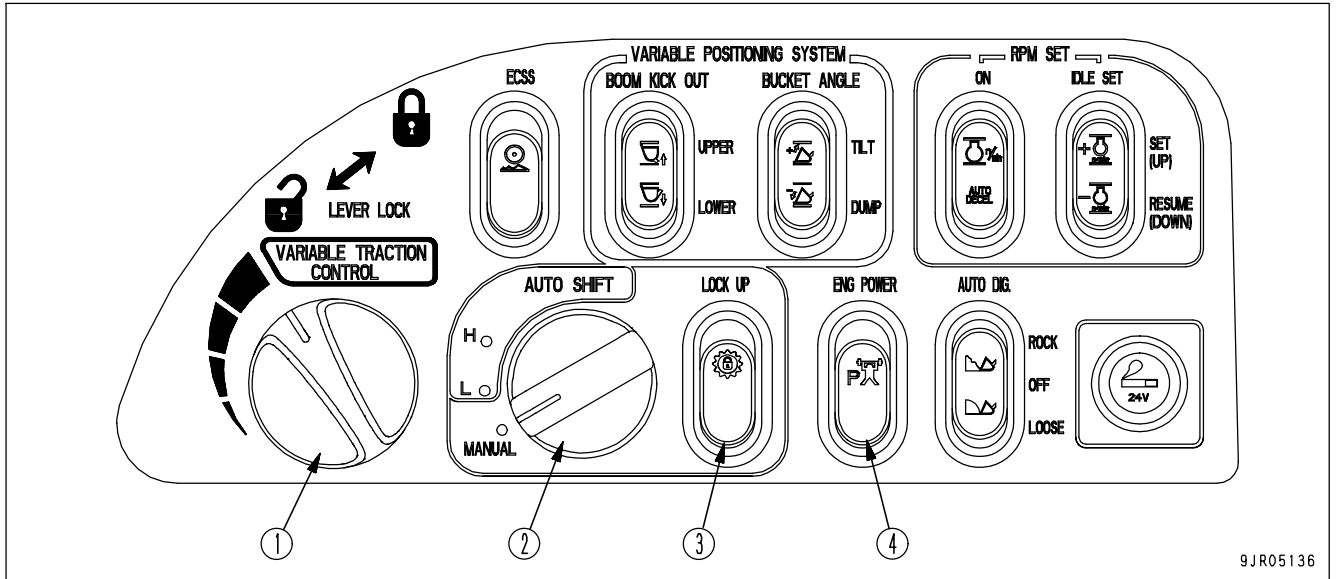

- (1) Driving force control dial
- (2) Transmission auto shift/manual shift selector switch
- (3) Torque converter lock-up switch
- (4) Engine power mode selector switch

Operation	Material	Working area	(1) Driving force control	(2) Auto shift			(3) Lock up		(4) Engine power	
				Manual	L	H	ON	OFF	Economy	Power
V-Shape loading	Stock piling	Flat & Solid ground	100%	o				o	o	
		Slippery ground	20 - 100%	o				o	o	
	Rock	Flat & Solid ground	100%	o				o	o	
		Slippery ground	80 - 100%	o				o	o	
		When high production is required	100%	o				o		o
Load & Carry		Level ground	100%		o		o		o	
		Uphill grade	100%			o	o			o
Traveling		Level ground	100%		o		o		o	
		Uphill grade	100%			o	o			o

CLICK HERE TO **DOWNLOAD** THE COMPLETE MANUAL

- Thank you very much for reading the preview of the manual.
- You can download the complete manual from: www.heydownloads.com by clicking the link below



- Please note: If there is no response to CLICKING the link, please download this PDF first and then click on it.

CLICK HERE TO **DOWNLOAD** THE COMPLETE MANUAL

BUCKET DUMP OPERATION WHEN DIGGING

Do not operate the bucket in the DUMP direction when digging. If the bucket control lever is operated to the DUMP position during digging, the machine will not be able to travel forward, the tires will slip, and an excessive load will be brought to bear on the work equipment.

Carry out the scooping-up operations as follows.

1. When thrusting the bucket in, raise the lift arm slightly at the same time. Ample driving force will work on the front wheels.
2. To fill the bucket, operate the bucket tilt and lift 2 - 3 times repeatedly when thrusting the bucket in.
Operate the control lever slowly near the end of the bucket tilt.
3. When the bucket reaches the end of the tilt stroke, depress the brake pedal to stop the machine.

When doing this, do not push the bottom of the bucket against the dilution. If the bucket is pushed against the dilution, the bucket, cylinders, and work equipment will be damaged.

4. When the scooping-up operation is completed, operate the bucket tilt and dump, and apply the brakes when traveling in reverse to stabilize the load inside the bucket and prevent spillage of the load.

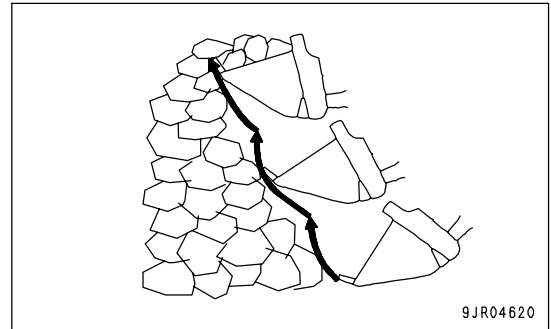
**REMARK**

- To reduce the generation of heat by the torque converter, keep the target time for the digging operation within 10 seconds from the start of thrusting in to the completion of scooping up.
- The fuel consumption increases while digging working. Fuel cost is saved by shortening the digging time.

FRONT WHEELS GOING ON BLASTED ROCK

Do not carry out operations that make the front wheels ride up on blasted rock. If the front wheels go on top of blasted rock, there is danger that the sharp parts of the blasted rock will cut the tires.

In particular, avoid pushing the bucket in too far, and when operating near natural rock after blasting (roots), do not let the front wheels ride up on the natural rock (roots). For scooping-up operations near natural rock (roots), do not use a wheel loader. Use a bulldozer or hydraulic excavator.

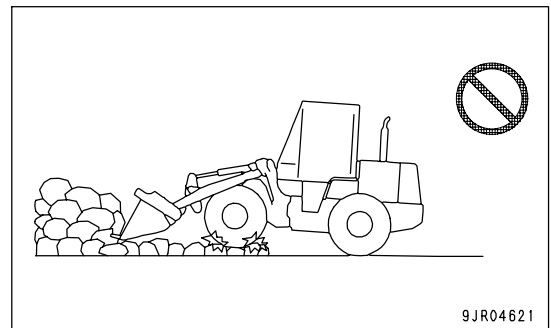

PRECAUTIONS FOR OPERATION

PERMISSIBLE WATER DEPTH

When working in water or on swampy ground, do not let the water come above the bottom of the axle housing.

After finishing the operation, wash and check the lubricating points.

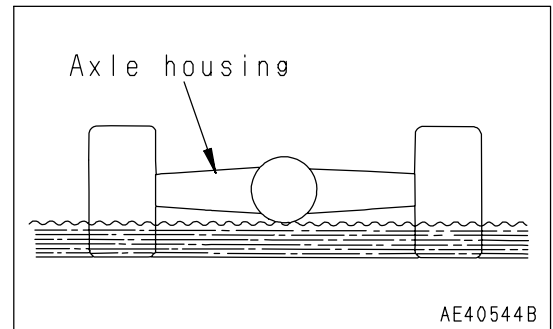

IF WHEEL BRAKE DOES NOT WORK

If the machine is not stopped by depressing the brake pedal, use the parking brake to stop the machine.

NOTICE

If the parking brake has been used as an emergency brake, contact your Komatsu distributor to have the parking brake checked for any abnormality.

HANDLING THE TIRES

PRECAUTIONS WHEN HANDLING TIRES

 **CAUTION**

If a tire has reached any of the following service limits, there is danger that the tire may burst or cause an accident, so to ensure safety, replace it with a new tire.

- **Service limits for wear**
 - When the remaining depth of the grooves on construction equipment tires (at a point approx. 1/4 of the tread width) is 15% of the groove depth on a new tire.
 - When the tire shows marked uneven wear, stepped wear or other abnormal wear, or when the cord layer is exposed.
- **Service limits for damage**
 - When there is external damage extending to the cord or when the cord is broken
 - When the cord is cut or there is dragging
 - When the tire is peeling (there is separation)
 - When the bead is damaged
 - For tubeless tires, when there is air leakage or improper repair

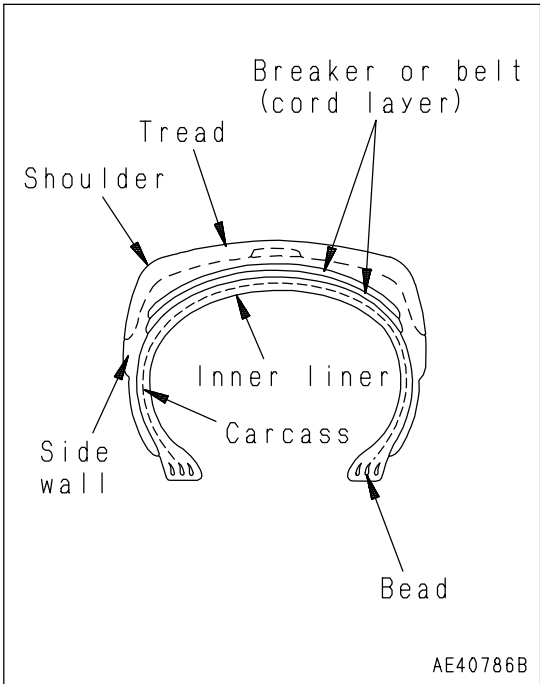

Please contact your Komatsu distributor when replacing the tires. It is dangerous to jack up the machine without taking due care.

TIRE PRESSURE

Measure the tire pressure before starting operations, when the tires are cool.

If the tire inflation pressure is too low, there will be overload; if it is too high, it will cause tire cuts and shock burst. To prevent these problems, adjust the tire inflation pressure according to the table on the next page.

Deflection ratio = $H - h / H \times 100$

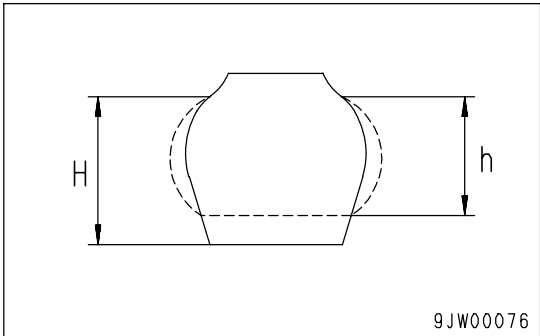

As a guideline that can be checked visibly, the deflection ratio of the front tire (deflection/free height) is as follows.

- When carrying normal load (lift arm horizontal): Approx. 15 to 25 %
- When digging (rear wheels off ground): Approx. 25 to 35 %

When checking the tire inflation pressure, check also for small scratches or peeling of the tire, for nails or pieces of metal which may cause punctures, and for any abnormal wear.

BATTERY

 **WARNING**

- The battery generates flammable gas. Do not bring fire or sparks near the battery.
- Battery electrolyte is dangerous. If it gets in your eyes or on your skin, wash it off with a large amount of water and consult a doctor.
- Battery electrolyte dissolves paint. If it gets on the bodywork, wash it off immediately with water.
- If the battery electrolyte is frozen, do not charge the battery or start the engine with a different power source. There is danger that the battery may explode.
- Battery electrolyte is toxic. Do not let it flow into drainage ditches or spray it on to the ground surface.

When the ambient temperature drops, the capacity of the battery will also drop. If the battery charge ratio is low, the battery electrolyte may freeze. Maintain the battery charge as close as possible to 100%. Insulate it against cold temperature to ensure the machine can be started easily the next morning.

REMARK

Measure the specific gravity and calculate the charging rate from the following conversion table.

Electrolyte Temperature	20°C (68°F)	0°C (32°F)	-10°C (14°F)	-20°C (-4°F)
Charging Rate (%)				
100	1.28	1.29	1.30	1.31
90	1.26	1.27	1.28	1.29
80	1.24	1.25	1.26	1.27
75	1.23	1.24	1.25	1.26

- As the battery capacity drastically drops in low temperatures, cover or remove the battery from the machine, store the battery in a warm place, and install it again the next morning.
- If the electrolyte level is low, add distilled water in the morning before beginning work. Do not add water after the day's work to prevent diluted electrolyte in the battery from freezing during the night.

PRECAUTIONS AFTER COMPLETION OF WORK

To prevent mud, water, or the undercarriage from freezing and making it impossible for the machine to move on the following morning, observe the following precautions.

- Remove all the mud and water from the machine body. In particular, wipe the hydraulic cylinder rods clean to prevent damage to the seal caused by mud, dirt, or drops of water on the rod from getting inside the seal.
- Park the machine on hard, dry ground.
If this is impossible, park the machine on boards.
The boards prevent the tracks from freezing to the ground, and allow the machine to be moved the next morning.
- Open the drain valve and drain any water collected in the fuel system to prevent it from freezing.
- Fill the fuel tank to capacity. This minimizes moisture condensation in the tank when the temperature drops.

AFTER COLD WEATHER

When the season changes and the weather becomes warmer, do as follows.

- Replace all fuel and oil with fuel and oil of the specified viscosity. For details, see "RECOMMENDED FUEL, COOLANT, AND LUBRICANT (PAGE 4-11)".

STARTING ENGINE WITH BOOSTER CABLE

When starting the engine with a booster cable, do as follows.

PRECAUTIONS WHEN CONNECTING AND DISCONNECTING BOOSTER CABLE

WARNING

- When connecting the cables, never contact the positive (+) and negative (-) terminals.
- When starting the engine with a booster cable, wear safety glasses and rubber gloves.
- Be careful not to let the normal machine and problem machine contact each other. This prevents sparks from generating near the battery which could ignite the hydrogen gas given off by the battery.
- Make sure that there is no mistake in the booster cable connections. The final connection is to the engine block of the problem machine, but sparks will be generated when this is done, so connect to a place as far as possible from the battery.
- When disconnecting the booster cable, take care not to bring the clips in contact with each other or with the machine body.

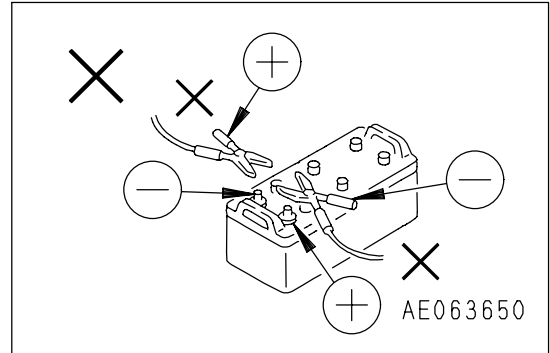

NOTICE

- The starting system on this machine is 24V. For the normal machine, use a machine that is also 24V.
- Always use a booster cable or clip of a thickness that is suitable for the size of the battery.
- For the battery on the normal machine, use a battery with the same capacity as the problem machine.
- Check that the cable and clips are not damaged or corroded.
- Connect the clips securely.
- Check that the lock levers (work equipment, steering) and parking brakes of both machines are at the LOCK position.
- Check that all levers are at the neutral position.

CONNECTING THE BOOSTER CABLE

Keep the starting switch of the normal machine and problem machine in the OFF position.

Connect the booster cable as follows, in the order of the numbers marked in the diagram.

1. Connect one clip of booster cable (A) to the positive (+) terminal of the problem machine.
2. Connect the other clip of booster cable (A) to the positive (+) terminal of the normal machine.
3. Connect one clip of booster cable (B) to the negative (-) terminal of the normal machine.
4. Connect the other clip of booster cable (B) to the engine block of the problem machine.

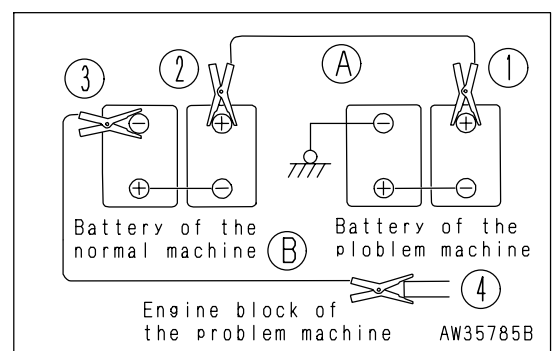

DUSTY WORKSITES:

When working at dusty worksites, do as follows:

- Check the air cleaner clogging caution lamp more frequently to check the degree of clogging of the air cleaner. Clean the air cleaner element more frequently.
- Clean the radiator core frequently to avoid clogging.
- Clean and replace the fuel filter frequently.
- Clean electrical components, especially the starting motor and alternator, to avoid accumulation of dust.
- When inspecting or changing the oil, move the machine to a place that is free of dust to prevent dirt from getting into the oil.

AVOID MIXING OIL:

If a different brand or grade of oil has to be added, drain the old oil and replace all the oil with the new brand or grade of oil. Never mix different brand or grade of oil.

LOCKING INSPECTION COVERS:

Lock inspection cover securely into position with the lock bar. If inspection or maintenance is performed with inspection cover not locked in position, there is a danger that it may be suddenly blow shut by the wind and cause injury to the worker.

BLEEDING AIR FROM HYDRAULIC CIRCUIT:

After repairing or replacing the parts of hydraulic circuit, or removing the piping of hydraulic circuit, it is necessary to bleed the air from inside of the circuit. See "BLEEDING AIR FROM HYDRAULIC TANK (PAGE 4-45)" for bleeding the air.

PRECAUTIONS WHEN INSTALLING HYDRAULIC HOSES:

- When removing parts at locations where there are O-rings or gasket seals, clean the mounting surface, and replace with new parts.
When doing this, be careful not to forget to assemble the O-rings and gaskets.
- When installing the hoses, do not twist them or bend them sharply. If they are installed so, their service life will be shortened extremely and they may be damaged.

CHECKS AFTER INSPECTION AND MAINTENANCE:

If you forget to perform the checks after inspection and maintenance, unexpected problems may occur, and this may lead to serious injury or property damage. Always do the following:

- Checks after operation (with engine stopped)
 - Have any inspection and maintenance points been forgotten?
 - Have all inspection and maintenance items been performed correctly?
 - Have any tools or parts been dropped inside the machine? It is particularly dangerous if parts are dropped inside the machine and get caught in the lever linkage mechanism.
 - Are there any leakage of coolant or oil? Have all nuts and bolts been tightened?
- Check when the engine is running
 - See "TWO WORKERS FOR MAINTENANCE WHEN ENGINE IS RUNNING (PAGE 2-39)" in the section on safety for checking when the engine is running. Pay attention to safety.
 - Check if the inspected and maintenance area is operating normally.
 - Increase the engine speed to check for fuel and oil leakage.

Capacity		Reservoir	Engine oil pan	Transmission case	Hydraulic system	Front axle	Rear axle	Pins	Fuel tank	Cooling system
Specified	Liters		97	120	592	155	155	-	718	182
	US gal		25.6	31.7	156.4	40.9	40.9	-	189.7	48.08
Refill	Liters		86	83	443	155	155	-	-	147
	US gal		22.7	21.9	117.0	40.9	40.9	-	-	38.8

NOTICE

Use only diesel fuel.

The engine mounted on this machine employs electronic control and a high-pressure fuel injection device to obtain good fuel consumption and good exhaust gas characteristics. For this reason, it requires high precision for the parts and good lubrication. If kerosene or other fuel with low lubricating ability is used, there will be a big drop in durability.

Always use the fuel specified for the temperature in the Operation and Maintenance Manual.

- If the fuel is used at temperatures lower than the specified temperature (particularly at temperatures below -15° C (5°F)), the fuel will solidify.
- If the fuel is used at temperatures higher than the specified temperature, the viscosity will drop, and this may result in problems such as a drop in output.

Note 1: HTHS (High-Temperature High-Shear Viscosity 150°C), specified by ASTM D4741 must be equal to or higher than 3.5 mPa·S. Komatsu EOS0W30 and EOS5W40 are the most suitable oils.

Note 2: Powertrain oil has different properties from engine oil. Be sure to use the recommended oils.

Note .3: Axle oil AXO80 has the function of preventing squealing from the brakes and LSD (Limited Slip Differential). If only AXO80 is recommended, use Komatsu genuine AXO80 or equivalent.

Note .4: When the ambient temperature is higher than 45°C (113°F) and the machine operation hour is longer than 12 hours/day, then the use of TO50 instead of AXO80 is recommended.

Squealing of the brakes may occur with TO50, but there is no problem with the brake performance or durability.

For machines with LSD, use AXO80 regardless of the ambient temperature. Do not use TO50.

Note .5: If the machine is equipped with an auto-greasing device, use lithium-based grease No. 0 when operating at temperatures below -20°C (-4°F).

Note .6: Hyper grease (G2-T, G2-TE) has a high performance.

When it is necessary to improve the lubricating ability of the grease in order to prevent squeaking of pins and bushings, the use of G2-T or G2-TE is recommended.

Note .7: Use GL-5 class oil for the gear oil. Do not use GL-4 class oil.

WHEN REQUIRED

CHECK, CLEAN, OR REPLACE AIR CLEANER ELEMENT

⚠ WARNING

- If inspection, cleaning, or maintenance is carried out with the engine running, dirt will get into the engine and damage it. Always stop the engine before carrying out these operations.
- When using compressed air, there is danger that dirt may be blown around and cause serious injury. Always use protective glasses, dust mask, and other protective equipment.

CHECKING

If air cleaner clogging caution lamp (1) on the machine monitor lights up, clean the air cleaner element.

NOTICE

Do not clean the element until the air cleaner clogging caution lamp lights up.

If the element is cleaned frequently before the air cleaner clogging caution lamp lights up, the air cleaner will not be able to display its performance fully and the cleaning efficiency will drop.

In addition, the frequency of dirt stuck to the element falling inside the inner element will increase.

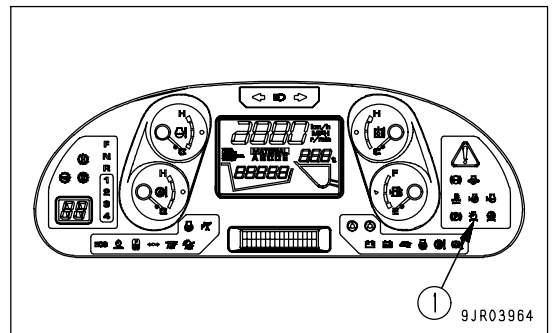

REMARK

A dust indicator (with 5-stage display) is installed to the side of the air cleaner. This displays the condition of the clogging of the air cleaner.

This makes it possible to check the clean status of the element and the replacement time.

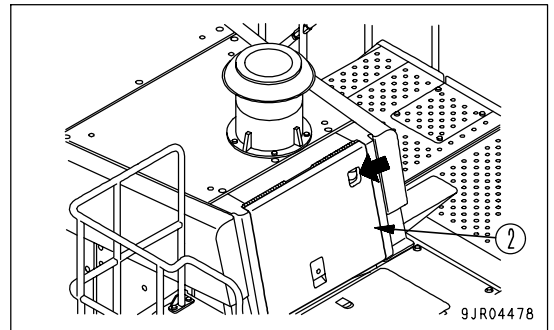

CLEAN AXLE CASE BREATHER

1. Stop the machine in a horizontal place.
2. Stop the engine.
3. Use a brush to clean off any mud or dirt from around the breather.
4. After removing all the mud or dirt from around the breather, remove the breather, and soak it in flushing liquid to clean it.

When cleaning the breather, clean the breathers at two places (front and rear).

After removing the breather, take steps to prevent dirt or dust from entering the mount.

5. Install the breather.

Front

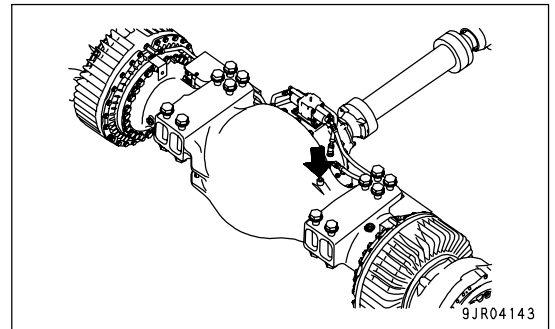

Rear

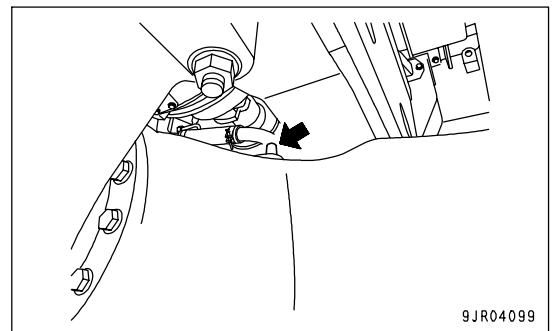

CHECK AIR CONDITIONER

CHECK LEVEL OF REFRIGERANT (GAS)

 **WARNING**

If the refrigerant used in the air conditioner gets into your eyes or on your hands, it may cause loss of sight or frostbite. Do not touch the refrigerant. Never loosen any part of the refrigerant circuit. Do not bring any flame close to any point where the refrigerant gas is leaking.

If there is a lack of refrigerant (gas), the cooling performance will be poor. When operating the air conditioner at high speed with the engine at full throttle, use the receiver sight glass (inspection window) to check the condition of the refrigerant gas (R134a) flowing in the refrigerant circuit.

1. Start the engine.
2. Run the air conditioner at maximum cooling.
3. Open the cover at the rear of the operator's compartment.
4. Look at the sight glass (inspection window) of the receiver to check the condition of the refrigerant gas (Freon R134a) flowing through the refrigerant circuit.
 - No bubbles in refrigerant flow: Suitable
 - Some bubbles in flow (bubbles pass continuously): Lack of refrigerant
 - Colorless, transparent: No refrigerant

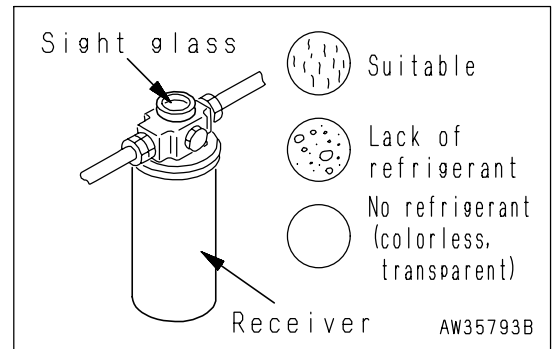

REMARK

When there are bubbles, the refrigerant gas level is low, so contact your Komatsu distributors to have refrigerant added. If the air conditioner is run with the refrigerant gas level low, it will cause damage to the compressor.

OPERATING THE AIR CONDITIONER OFF-SEASON

Even during the off-season, operate the air conditioner for 3 to 5 minutes once a month to maintain the oil film at all parts of the compressor.

CHECK BEFORE STARTING

For the following items, see "CHECK BEFORE STARTING (PAGE 3-121)".

- Check machine monitor
- Check dust indicator
- Check fuel pre-filter, drain water
- Check coolant level, add coolant
- Check oil level in engine oil pan, add oil
- Check fuel level, add fuel
- Check electric wiring
- Check parking brake
- Check brake pedal
- Check inflation pressure of tires
- Check waterproof/fireproof dividing walls

CHECKING FUNCTION OF ACCUMULATOR

For details of handling the accumulator, see Section "HANDLING ACCUMULATOR AND GAS SPRING (PAGE 2-45)".

BRAKE ACCUMULATOR

If the engine stops when the machine is traveling, the oil pressure in the accumulator can be used to apply the brake as an emergency measure.

1. Stop the machine on level ground and lower the work equipment completely to the ground.
2. Apply the parking brake.
3. Start the engine, run it at a mid-range speed for 1 minute, then stop the engine.
4. Turn the starting switch key to the ON position and depress the brake pedal repeatedly.
 - If the brake oil pressure caution lamp does not light up even when the brake is depressed 6 times, the gas pressure in the accumulator is normal.
 - If the brake oil pressure caution lamp lights up when the brake has been depressed 5 or less times, the gas pressure in the accumulator has probably dropped. Please contact your Komatsu distributor to have the accumulator inspected.

REMARK

Carry out the check within 5 minutes after stopping the engine. If the machine is left with the engine stopped, the accumulator pressure will drop and it will be impossible to check the cause of the problem.

12. Pour in the specified amount of engine oil from oil filler (F).
13. After adding oil, check that the oil is at the specified level. For details, see "CHECK TRANSMISSION OIL LEVEL, ADD OIL (PAGE 4-30)".
14. Check that there is no leakage of oil from the transmission case or oil filter.

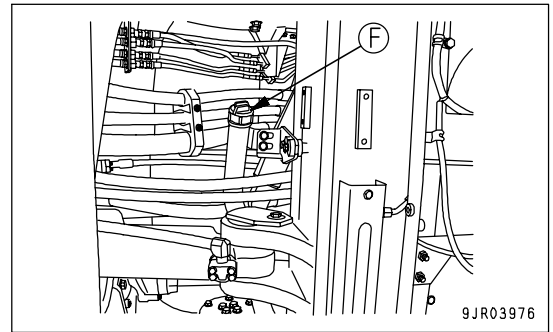

CLEAN TRANSMISSION CASE BREATHER

1. Stop the engine and wait for the temperature at all parts to go down.
2. Remove all mud and dirt from around the breather.
3. Remove the breather and fit a cover to the breather mounting hole to prevent dirt from entering.
4. Soak the breather in flushing liquid and wash it.
5. Install the breather.

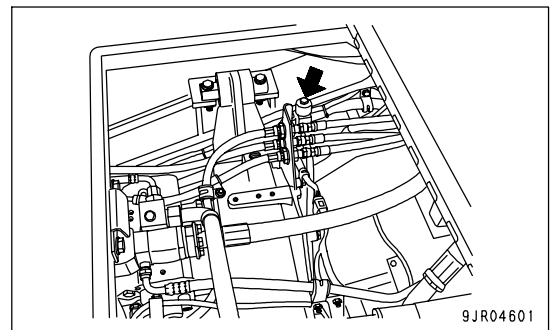

CHECK ALTERNATOR

When carrying out the EVERY 2000 HOURS SERVICE or EVERY YEAR SERVICE, remove the belt and check that the alternator rotates smoothly. If it does not rotate smoothly, please ask your Komatsu distributor to carry out inspection and repair.

CHECK ENGINE VALVE CLEARANCE, ADJUST

As special tool is required for removing and adjusting the parts, request your Komatsu distributor for service.

CHECK BRAKE DISC WEAR

As special tool is required for checking and adjusting the parts, request Komatsu distributor for service.

CHECKING FUNCTION OF ACCUMULATOR

For details of handling the accumulator, see Section "HANDLING ACCUMULATOR AND GAS SPRING (PAGE 2-45)".

PPC ACCUMULATOR

If the engine stops with the work equipment raised, and it is impossible to start the engine again, it is possible as an emergency measure to actuate the valve with the oil pressure stored in the accumulator and lower the work equipment to the ground.

1. Apply the parking brake.
2. Raise the work equipment to the maximum height, then operate the lift arm control lever to HOLD position (b).
3. Stop the engine.
4. Leave the work equipment lock lever in the FREE position.
5. Check that the area around the machine is safe, then turn the starting switch to the ON position, set the lift arm control lever to FLOAT position (d), and lower the work equipment to a point 1 m (3 ft 3 in) above the ground.
6. When the lift arm comes to the 1 m position, return the lift arm control lever to LOWER position (c), and lower the work equipment slowly to the ground.

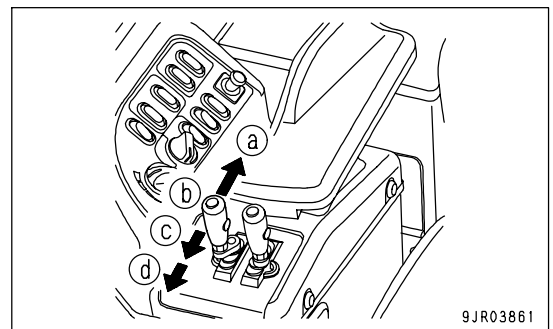

REMARK

Carry out the check within 2 minutes after stopping the engine. If the machine is left with the engine stopped, the accumulator pressure will drop and it will be impossible to check the cause of the problem.

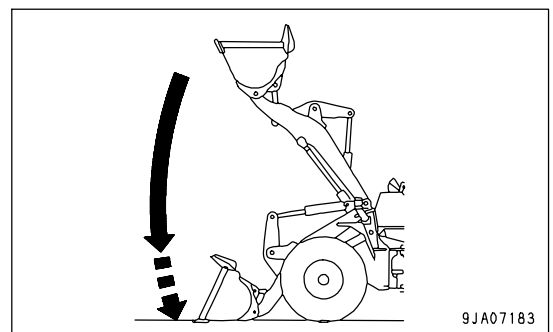

If the work equipment stops while it is moving, the gas pressure in the accumulator has probably dropped. Please contact your Komatsu distributor to have the accumulator inspected. Replace the accumulator every 4000 hours or every 2 years.

CHECK BOOST PIPING CLAMPS

Check the clamps of the hoses between the air cleaner and the turbocharger. Tighten any loose clamps. Check the clamps of the hoses between the turbocharger and the aftercooler or engine. Tighten any loose clamps.

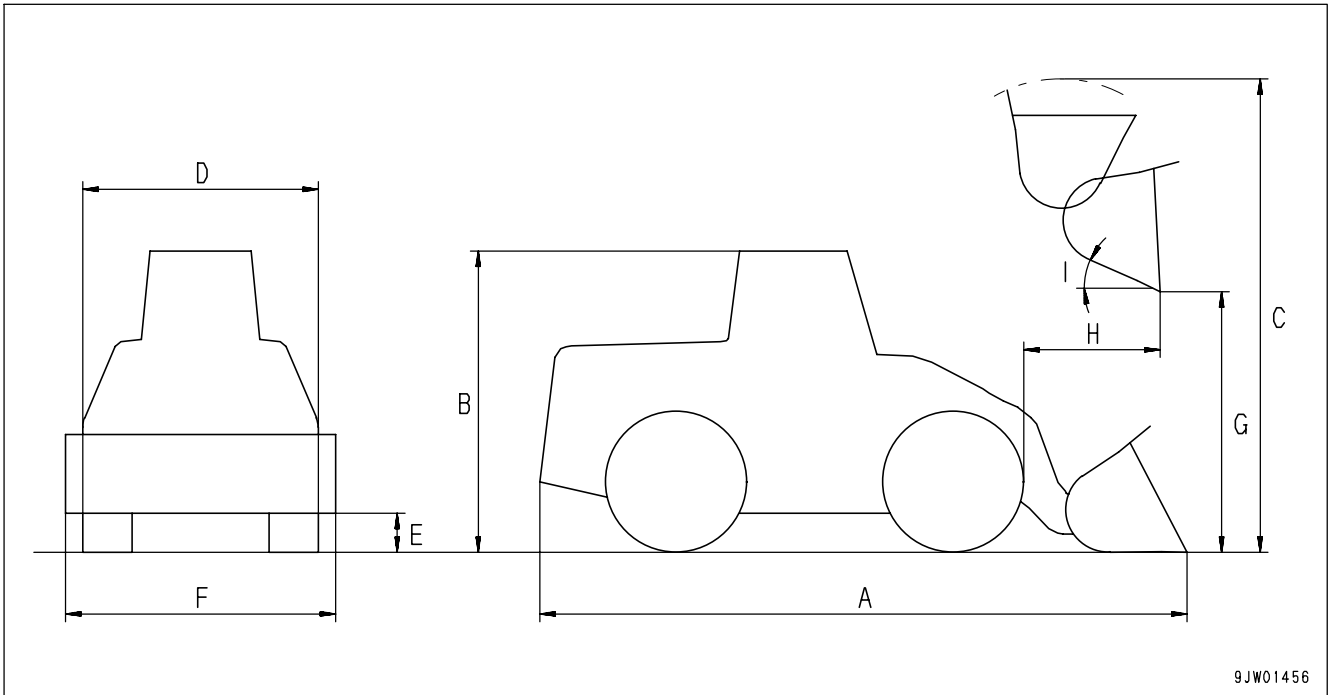

OVERHEAD PORTION

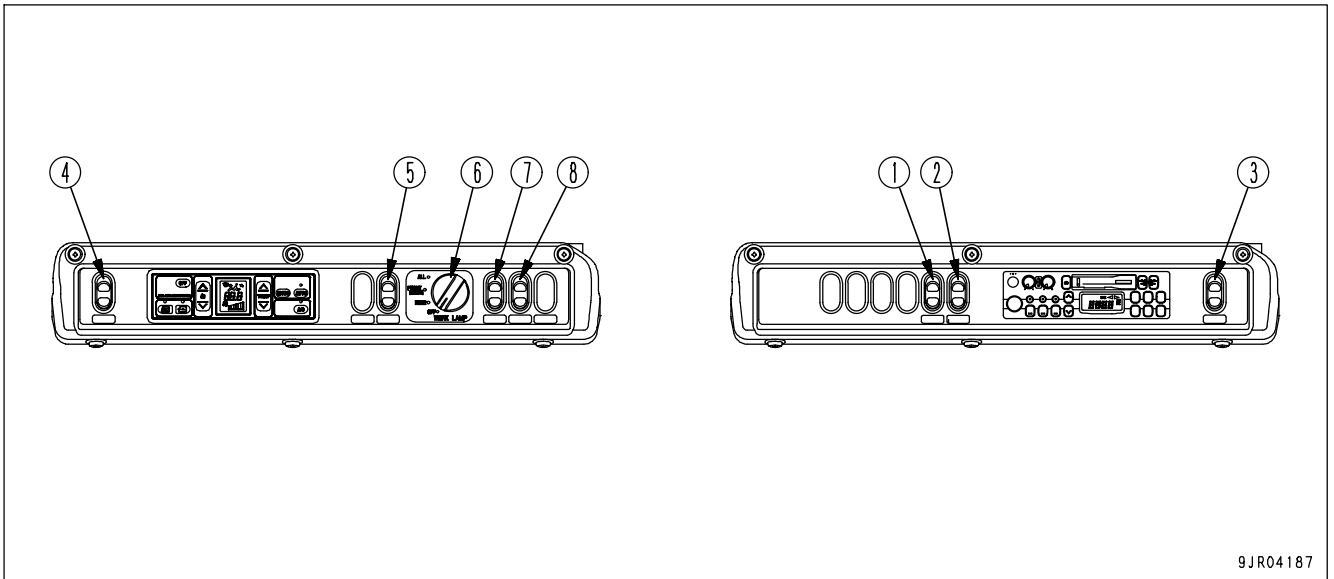

- | | |
|---|--------------------------------------|
| (1) Auto-greasing switch (if equipped) | (5) Side wiper switch (if equipped) |
| (2) Cooling fan reverse rotation switch | (6) Working lamp switch |
| (3) Step lamp switch | (7) Fog lamp switch (if equipped) |
| (4) Rear heated wire glass switch | (8) Beacon lamp switch (if equipped) |

For details of switches (1) - (8), see "SWITCHES (PAGE 3-50)" in the OPERATION section.

MOVING MACHINE OFF (MACHINES EQUIPPED WITH STEERING WHEEL)

 **WARNING**

- Regardless of whether the engine is running or not, always check that the work equipment lock lever is securely at the LOCK position before standing up from the operator's seat.
- There is danger that if the work equipment control levers are touched by accident when the engine is started, the work equipment or machine may move unexpectedly and cause serious personal injury.
- When traveling, always release the frame lock bar. If it is not removed, the steering will not work and this may lead to a serious accident or personal injury.
- When moving the machine off, check that the area around the machine is safe, then sound the horn before starting.
- Do not allow people to get near the machine.
- Clear the machine's travel path of any obstacle.
- Pay a particular attention to the blind spot at the rear of the machine, when traveling the machine in reverse.
- When starting the machine off up a slope, depress the left brake pedal, then gradually depress the accelerator pedal and let the brake pedal back to allow the machine to move off. This will prevent the machine from rolling back.

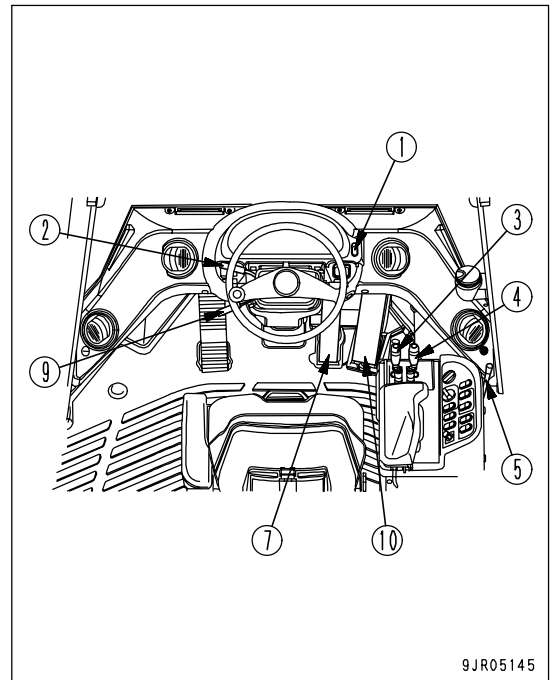

9JR05145

1. Fasten the seat belt.
2. Check that parking brake switch (1) is at the ON position.

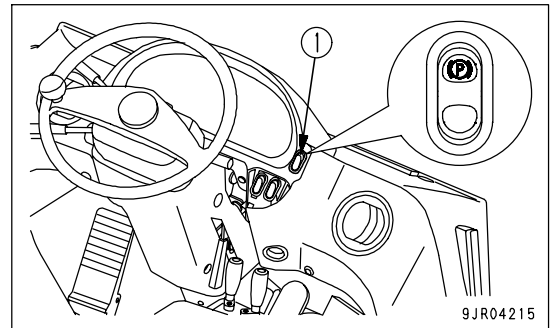

9JR04215

3. Check that directional lever (2) is at the N position.
When starting the engine, if directional lever (2) is not at the N position, the engine will not start.

REMARK

If the directional lever is not at the N position, the alarm buzzer will emit short sounds.

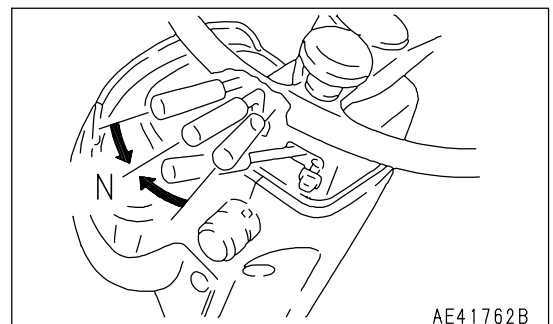

AE41762B

HANDLING LOAD METER

OUTLINE OF LOAD METER

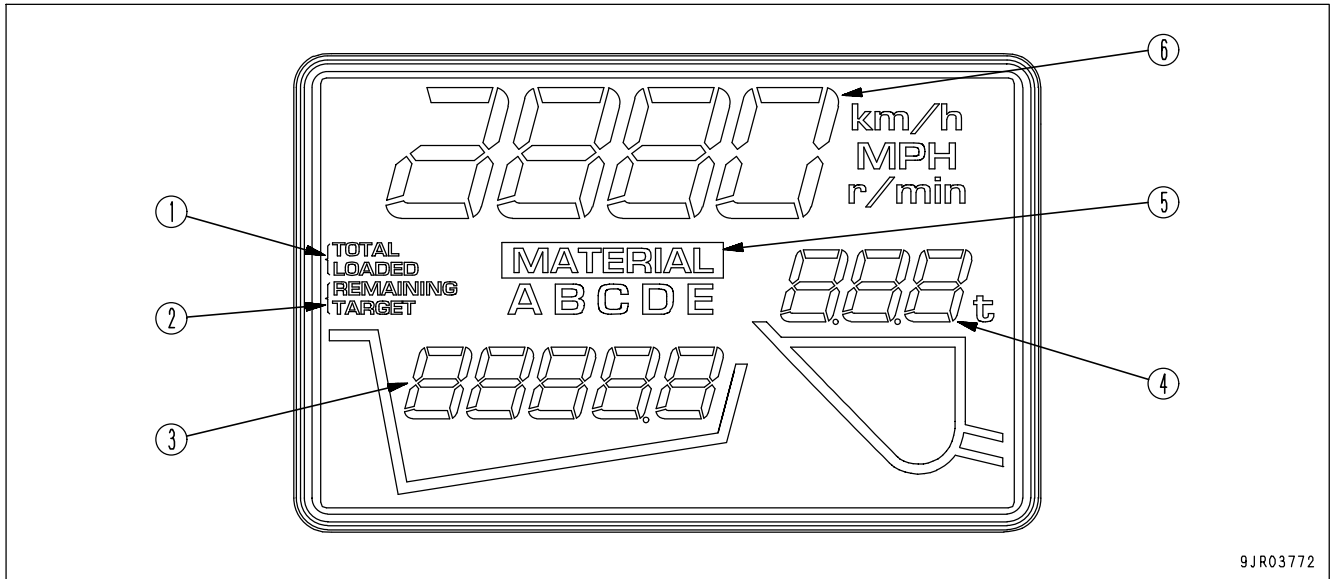

9JR03772

- | | |
|--|---|
| (1) Addition mode display | (4) Bucket load display |
| (2) Subtraction mode display | (5) Target load display |
| (3) Total load display/load remaining to target load display | (6) Travel speed display/engine speed display |

The load meter divides the type of material being handled into five categories. It measures the load in the bucket and displays the total load or the load remaining to the target load.

The total load or load remaining to the target load can be displayed from 0.1 tons to a maximum of 99999 tons, but up to 9999.9 tons, the digit shown after the decimal point displays the load in units of 100 kg. When the load exceeds 10000 tons, the decimal point disappears and the display is shown in units of 1 ton.

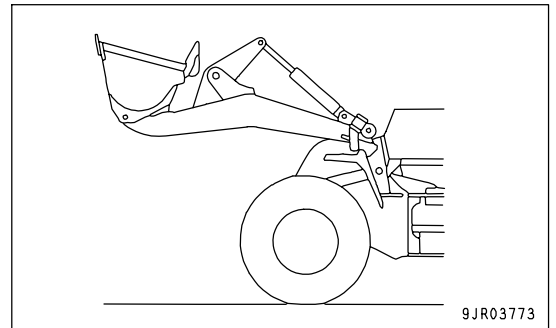

9JR03773

The load meter has two modes: addition mode and subtraction mode.

Addition mode: The display shows the load in the bucket added to the existing total load. This is useful for calculating the production within a fixed time or when loading a dump truck or hopper.

For details of setting the addition mode, see "SETTING ADDITION MODE (PAGE 6-32)".

Subtraction mode: The display shows the load in the bucket subtracted from the remaining target load. When the target load becomes "0", the loading is completed.

This is useful for calculating a fixed load.

For details of setting the subtraction mode, see "SETTING SUBTRACTION MODE (PAGE 6-33)".

The load meter can divide the type of material being handled into five categories. It can save to memory the total load or the load remaining to the target load for each category.

For details of setting the load material category, see "SELECTING LOAD MATERIAL CATEGORY DISPLAY (PAGE 6-41)".

TOTAL LOAD DATA DISPLAY

1. Press the top of the load meter display selector switch. "TOTAL DATA" is displayed on the character display. The bottom line shows the time that the loading was carried out.

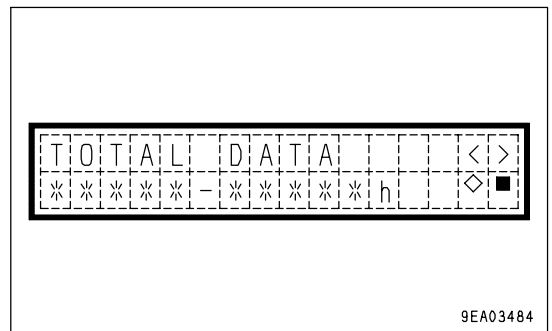
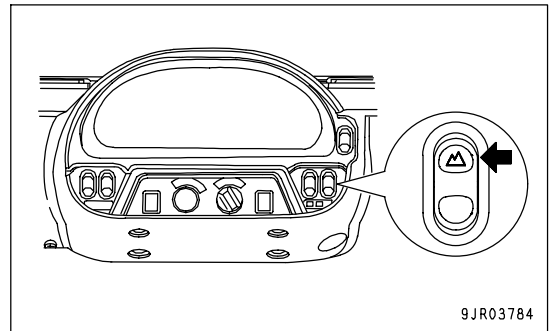

2. Press the load meter mode selector switch (A/B). Each time the switch is pressed, "MATERIAL" changes from A → B → C → D → E → A. When this happens, the load for the category of material displayed in "MATERIAL" is displayed on load meter display portion (2) and the number of loads is displayed on load meter display portion (3).

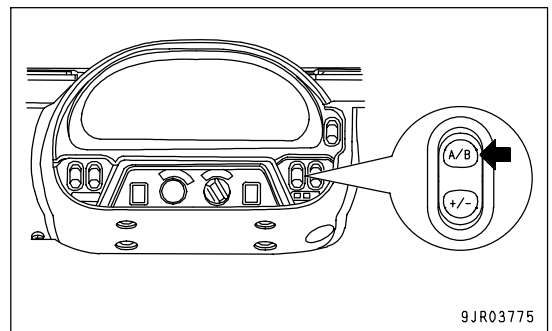

REMARK

A, B, C, D, E (all lamps light up) displays the load, regardless of material category A, B, C, D, E.

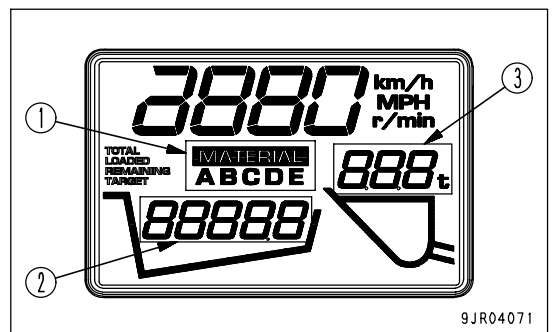

8. Tilt the bucket back fully, then lower the lift arm to set to the travel posture.

When the lift arm is lowered, the display on the character display changes to "STEP 2 RAISE TO TOP".

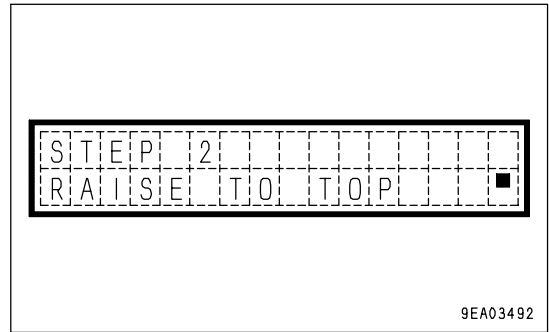

9. Raise the lift arm to the maximum height at the same speed as for actual operations.

Depress the accelerator pedal to the same angle as for actual operations. Keep the accelerator angle constant and do not change it. Carry out the lift arm RAISE at the detent.

10. When the calibration is completed correctly, the screen for inputting the weight is displayed.

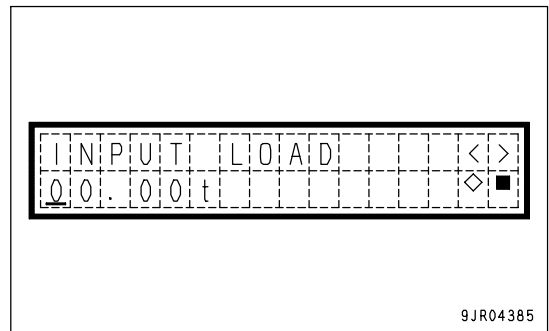

REMARK

For details of the method of inputting, see "SETTING SUBTRACTION MODE (PAGE 6-33)".

The load meter automatically judges if it is "1/2 rated load calibration" or "rated load calibration", and rewrites the data. Even if the input value is the same as the previous value, input the weight.

When the weight is input, the buzzer sounds and the character display returns to the normal service meter and clock display.

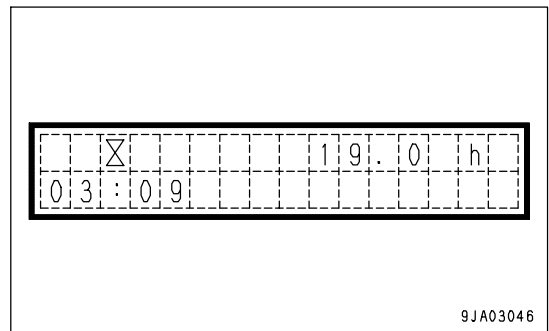

If the calibration when loaded cannot be completed normally, the buzzer sounds, "CALIBRATION" appears on the top line of the character display, and "LOAD BUCKET" appears on the bottom line.

11. If the calibration when loaded cannot be completed normally, carry out the operation again from Step 6.

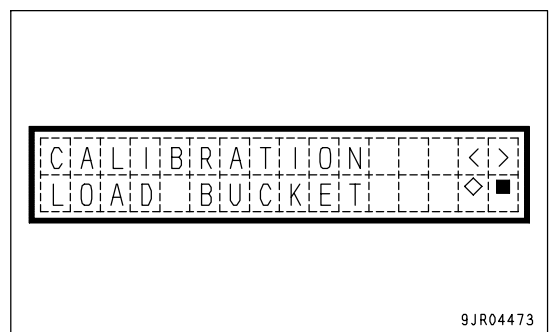

SELECTION OF PRINTOUT MODE

1. Check that the character display shows the normal service meter and clock display.

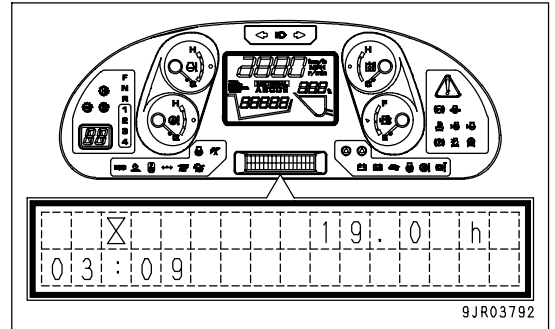

2. Press the (◇) portion of the machine monitor mode selector switch 1 and display "LOAD METER" on the character display.

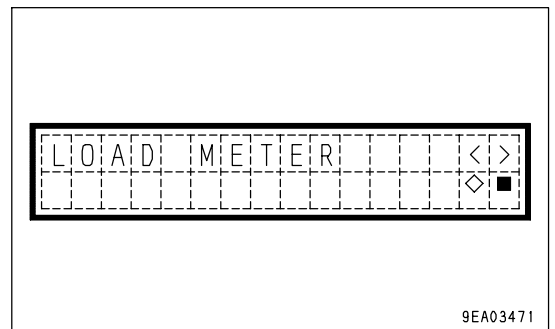
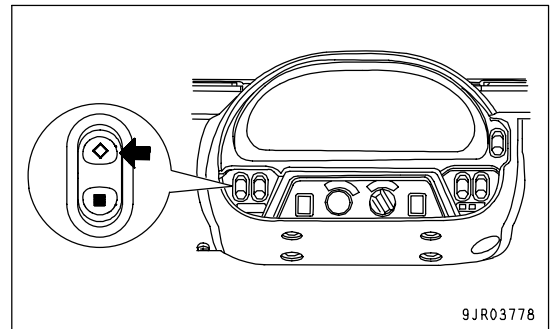

PRECAUTIONS WHEN HANDLING AUTO-GREASING SYSTEM

- Basically, the power source input to the lubrication controller should be DC24V, but use a maximum limit of 30V.
- The grease nipple installed to the service port used for initial charging of the divider valve has a ball check structure, so it may leak if dirt gets stuck in it.
Check it from time to time, and replace the grease nipple immediately if any grease is leaking.
- When carrying out initial operation or when the grease tank is empty, air may get into the piston portion of the pump. If the pressure does not rise within the specified time when running the pump, and an error is displayed for the controller, bleed the air.
- If the divider valve or grease piping are removed when replacing the attachment on the machine, handle carefully to prevent any damage. When storing or installing again, be extremely careful to prevent the entry of air, and particularly dirt. If there is any air in the system, bleed the air immediately.

TROUBLESHOOTING

If any abnormality occurs in the greasing system, the error codes will flash alternately to display the type of abnormality.

Error code	Item	Cause	Remedy
E → a	Defective pressurizing of pump	<ul style="list-style-type: none"> • Air in main piping • Air inside pump • Grease tank is empty • Grease leaking from main piping 	<ul style="list-style-type: none"> • Run pump as necessary and release grease from end of piping to bleed air • Release grease from air bleed in pump to bleed air • Add grease • Check, tighten connections of main piping (including hoses)
E → b	Abnormality in release of pressure	<ul style="list-style-type: none"> • Abnormality in pressure-releasing structure built into pump • Abnormality in pressure-detection equipment built into pump 	<ul style="list-style-type: none"> • Disassemble pressure-releasing portion carefully, then check and clean • Check limit switch at pressure-detection portion
E → c	Abnormality in pressure detection	<ul style="list-style-type: none"> • Abnormality in pressure-detection equipment built into pump • Abnormality in pressure-releasing structure built into pump 	<ul style="list-style-type: none"> • Check limit switch at pressure- detection portion • Disassemble pressure-releasing portion carefully, then check and clean
E → 0	Empty tank	<ul style="list-style-type: none"> • Greasing frequency limit has been reached • Grease added during frequency count 	<ul style="list-style-type: none"> • Add grease Reset frequency counter to zero. • Confirm that 0 flashes three times on 7-segment LED by pressing reset button on controller for more than 5 seconds.

- 6. Push the bottom of quick coupler switch (2) lightly to return it to the Neutral position.
When this happens, unlock indicator lamp (1) goes out.

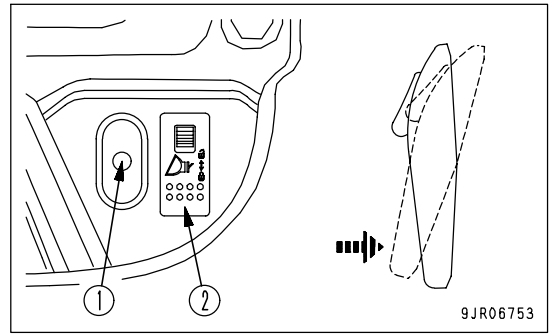

CLICK HERE TO **DOWNLOAD** THE COMPLETE MANUAL

- Thank you very much for reading the preview of the manual.
- You can download the complete manual from: www.heydownloads.com by clicking the link below



- Please note: If there is no response to CLICKING the link, please download this PDF first and then click on it.

CLICK HERE TO **DOWNLOAD** THE COMPLETE MANUAL