

Operation & Maintenance Manual

WHEEL LOADER

WA600-3

SERIAL NUMBERS 52001 and up

⚠ WARNING

Unsafe use of this machine may cause serious injury or death. Operators and maintenance personnel must read this manual before operating or maintaining this machine. This manual should be kept near the machine for reference and periodically reviewed by all personnel who will come into contact with it.

NOTICE

Komatsu has Operation & Maintenance Manuals written in some other languages. If a foreign language manual is necessary, contact your local distributor for availability.

KOMATSU

CLICK HERE TO **DOWNLOAD** THE COMPLETE MANUAL

- Thank you very much for reading the preview of the manual.
- You can download the complete manual from: www.heydownloads.com by clicking the link below



- Please note: If there is no response to CLICKING the link, please download this PDF first and then click on it.

CLICK HERE TO **DOWNLOAD** THE COMPLETE MANUAL

CONTENTS

FOREWORD	1- 1
FOREWORD	1- 2
SAFETY INFORMATION	1- 5
INTRODUCTION	1- 7
FRONT/REAR, LEFT/RIGHT DIRECTIONS OF MACHINE	1- 7
NECESSARY INFORMATION	1- 8
PRODUCT IDENTIFICATION NUMBER (PIN)/MACHINE SERIAL NO. PLATE	1- 8
ENGINE SERIAL NO. PLATE AND POSITION	1- 8
POSITION OF SERVICE METER	1- 9
TABLE TO ENTER SERIAL NO. AND DISTRIBUTOR	1- 9
SAFETY	2- 1
SAFETY	2- 2
SAFETY LABELS	2- 4
LOCATION OF SAFETY LABELS	2- 5
GENERAL PRECAUTIONS	2- 11
PRECAUTIONS FOR OPERATION	2- 20
STARTING ENGINE	2- 20
OPERATION	2- 22
TRANSPORTATION	2- 28
BATTERY	2- 29
TOWING	2- 31
PRECAUTIONS FOR MAINTENANCE	2- 32
PRECAUTIONS WITH TIRES	2- 39
OPERATION	3- 1
GENERAL VIEW	3- 2
GENERAL VIEW OF MACHINE	3- 2
GENERAL VIEW OF CONTROLS AND GAUGES	3- 3
EXPLANATION OF COMPONENTS	3- 5
MACHINE MONITOR	3- 5
SWITCHES	3- 19
CONTROL LEVERS, PEDALS	3- 27
STEERING COLUMN TILT LEVER	3- 31
CAP WITH LOCK	3- 32
SAFETY BAR	3- 33
TOWING PIN	3- 33
GREASE PUMP	3- 34
BACKUP ALARM	3- 34
DUST INDICATOR	3- 34
CAB DOOR OPEN LOCK	3- 35
TOOL BOX	3- 35
OIL FILLER LOCATION	3- 35
FUSE	3- 35
SLOW BLOW FUSE	3- 37
LUNCH BOX TRAY	3- 37
POWER OUTLET	3- 37
OPERATION	3- 38
CHECK BEFORE STARTING ENGINE, ADJUST	3- 38
STARTING ENGINE	3- 53
OPERATIONS AND CHECKS AFTER STARTING ENGINE	3- 55

(7) Caution when coolant is at high temperature



(8) Caution when oil is at high temperature



(9) Caution when handling battery cable

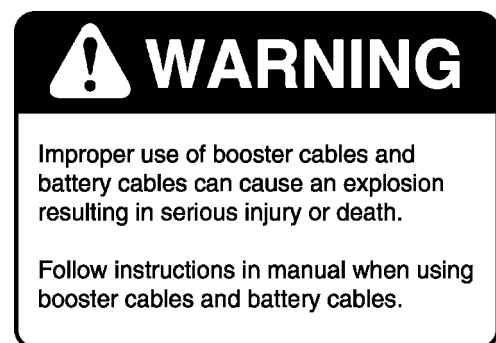

(10) Caution to prohibit going up on the hood (09805-13000)



- Even going close to high-voltage cables can cause electric shock, which may cause serious burns or even death. Always maintain a safe distance (see the table on the right) between the machine and the electric cable. Check with the local power company about safe operating procedure before starting operations.
- To prepare for any possible emergencies, wear rubber shoes and gloves. Lay a rubber sheet on top of the seat, and be careful not to touch the chassis with any exposed part of your body.
- Use a signalman to give warning if the machine approaches too close to the electric cables.
- When carrying out operations near high voltage cables, do not let anyone near the machine.
- If the machine should come too close or touch the electric cable, to prevent electric shock, the operator should not leave the operator's compartment until it has been confirmed that the electricity has been shut off. Also, do not let anyone near the machine.

Voltage of Cables	Safety Distance
100 V - 200 V	Over 2 m (7 ft)
6,600 V	Over 2 m (7 ft)
22,000 V	Over 3 m (10 ft)
66,000 V	Over 4 m (14 ft)
154,000 V	Over 5 m (17 ft)
187,000 V	Over 6 m (20 ft)
275,000 V	Over 7 m (23 ft)
500,000 V	Over 11 m (36 ft)

ENSURE GOOD VISIBILITY

- Check for any persons or obstacles in the area around the machine and check the conditions of the jobsite to ensure that operations and travel can be carried out safely. Always do as follows.
 - Position a signalman if there are areas at the rear of the machine where the visibility is not good.
 - When working in dark places, turn on the working lamp and front lamps installed to the machine, and set up additional lighting in the work area if necessary.
 - Stop operations if the visibility is poor, such as in mist, snow, rain, or dust.

PRECAUTIONS RELATED TO VENTILATION EXHAUST GAS

The engine exhaust gas contains substances that may damage your health or even cause death. Start or operate the engine in a place where there is good ventilation. If the engine or machine must be operated inside a building or under ground, where the ventilation is poor, take steps to ensure that the engine exhaust gas is removed and that ample fresh air is brought in.

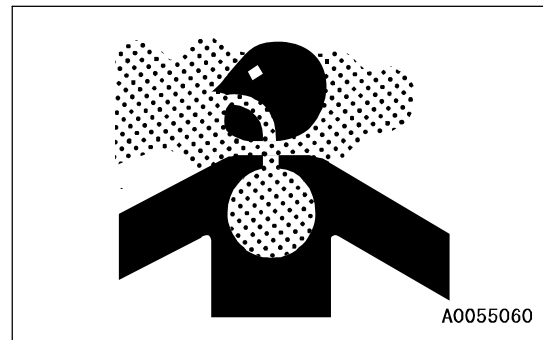

CHECKING SIGNALMAN'S SIGNALS AND SIGNS

- Set up signs to inform of road shoulders and soft ground. If the visibility is not good, position a signalman if necessary. Operators should pay careful attention to the signs and follow the instructions from the signalman.
- Only 1 signalman should give signals.
- Make sure that all workers understand the meaning of all signals and signs before starting work.

EMERGENCY EXIT FROM OPERATOR'S CAB

Machines equipped with a cab have doors on the left and right sides. If the door on the one side does not open, escape from the door on the other side.

TRANSPORTATION

The machine can be divided into parts for transportation, so when transporting the machine, please contact your Komatsu distributor to have the work carried out.

LOADING AND UNLOADING

When loading or unloading the machine, mistaken operation may bring the hazard of the machine tipping over or falling, so particular care is necessary. Always do as follows.

- Perform loading and unloading on firm, level ground only. Maintain a safe distance from the edge of the road or cliff.
- Always use ramps of adequate strength. Be sure that the ramps are wide, long, and thick enough to provide a safe loading slope. Take suitable steps to prevent the ramps from moving out of position or coming off.
- Be sure the ramp surface is clean and free of grease, oil, ice and loose materials. Remove dirt from machine-tracks. On a rainy day, in particular, be extremely careful since the ramp surface is slippery.
- Run the engine at low speed and travel slowly.
- Never correct your steering on the ramps. If necessary, drive off the ramps, correct the direction, then enter the ramps again.
- When loading or unloading to an embankment or platform, make sure that it has suitable width, strength, and grade.
- For machines equipped with a cab, always lock the door after boarding the machine. If this is not done, the door may suddenly open during transportation. Refer to "TRANSPORTATION (PAGE 3-85)".

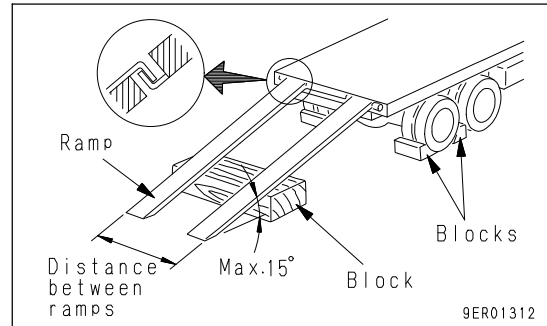

SHIPPING

When shipping the machine on a trailer, do as follows.

- The weight, transportation height, and overall length of the machine differ according to the work equipment, so be sure to confirm the dimensions.
- When passing over bridges or structures on private land, check first that the structure is strong enough to support the weight of the machine. When traveling on public roads, check first with the relevant authorities and follow their instructions.
- Lock the frame with the safety bar to prevent the machine from articulating.
- For details of the shipping procedure, see "TRANSPORTATION (PAGE 3-85)" in the OPERATION section.

COMPRESSED AIR

- When carrying out cleaning with compressed air, there is a hazard of serious injury caused by flying particles.
- When using compressed air to clean elements or the radiator, always wear safety glasses, dust mask, gloves, and other protective equipment.

PERIODIC REPLACEMENT OF SAFETY CRITICAL PARTS

- In order for the machine to be operated safely for a long time, it is necessary to add oil and to carry out service and maintenance at periodic intervals. In order to further increase safety, components with a strong relationship to safety, such as hoses and seat belts, must be replaced at periodic intervals.

Replacement of safety-critical parts: See "PERIODIC REPLACEMENT OF SAFETY CRITICAL PARTS (PAGE 4-13)".

- The material of these components naturally changes over time, and repeated use causes deterioration, wear, and fatigue. As a result, there is a hazard that these components may fail and cause serious injury or death. It is difficult to judge the remaining life of these components from external inspection or the feeling when operating, so always replace them at the specified interval.
- Replace or repair safety-critical parts if any defect is found, even when they have not reached the specified replacement time.

CENTRAL CHECK LAMP (CHECK)



If this monitor flashes, carry out inspection and maintenance of the appropriate location as soon as possible.

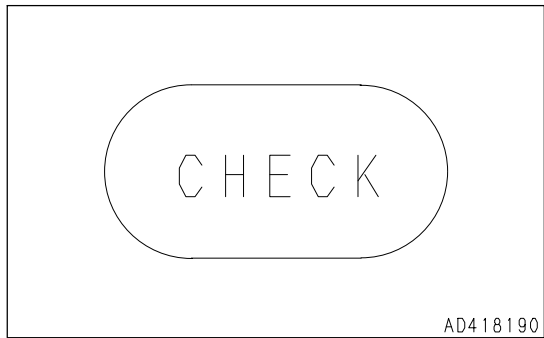

- If any abnormality is found in the CHECK items before starting the engine (engine oil level, engine water level), the monitor lamp for the abnormal location will flash and central check lamp (CHECK) (1) will also flash.

Check the location where the monitor lamp is flashing and carry out the check before starting.

When carrying out the checks before starting, do not rely simply on the monitor. Always carry out the specified check before starting items "CHECK BEFORE STARTING (PAGE 3-41)".

When carrying out checks before starting, if the engine oil level is abnormal, the engine oil level will change when the engine is started, so even if there is any abnormality, the central check lamp and monitor lamp will stop flashing.

If there is any abnormality in the engine water level, the central check lamp will go out when the engine is started, but instead of this, the central caution lamp will flash and the alarm buzzer will sound intermittently.

- If there is any abnormality in the battery charging system when the engine is running, the battery charge caution pilot lamp will flash and the central CHECK lamp (1) will also flash at the same time. If the lamps flash, check the charging circuit.

CENTRAL CAUTION LAMP (CAUTION)



If this monitor flashes, stop the engine immediately or run it at low idling and do as follows.

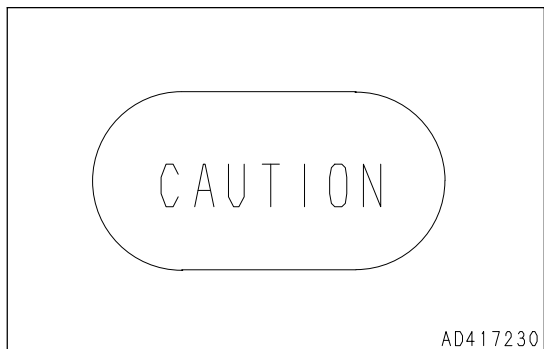

- If there is an abnormality in any CAUTION item when the engine is running (engine water temperature, torque converter oil temperature, engine water level, brake oil pressure, engine oil pressure), the alarm buzzer will sound intermittently and the monitor lamp for the location of the abnormality will flash and the central CAUTION lamp (2) will also flash.
- If the fuel gauge enters the red range when the engine is running, the fuel gauge will flash and the central CAUTION lamp (2) will also flash. If they flash, check the fuel level and add

When the F (FORWARD) or R (REVERSE) buttons of the FNR buttons on the head of the joystick lever are pressed, F or R is displayed at the bottom of the speedometer and the shift indicator displays the transmission speed range and N.

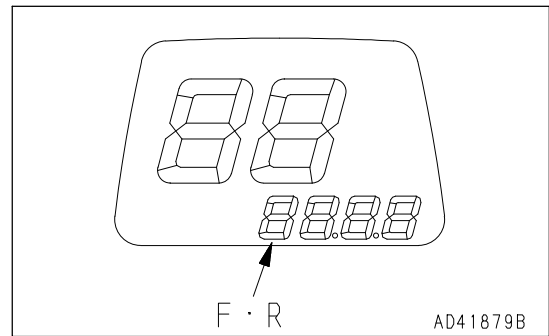

REMARK

The length of the lever can be adjusted to 3 stages (positions (A), (B), (C)). To adjust the length, remove the screw at the bottom of the lever knob, slide the knob to the desired position, then tighten the screw again.

(The lever is installed to position (B) when it is shipped from the factory.)

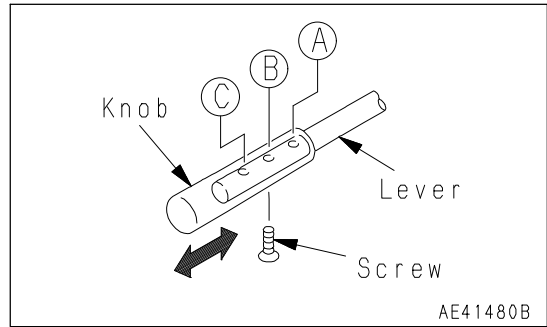

DIRECTIONAL LEVER

This lever (2) is used to switch the direction of travel of the machine between forward and reverse.

When starting the engine, if the directional lever is not at the N position, the engine will not start.

Position (a): FORWARD

Position N: NEUTRAL

Position (b): REVERSE

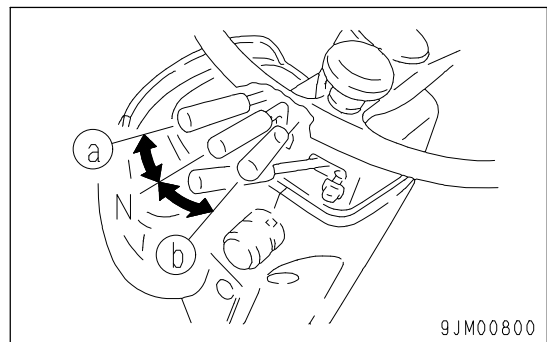

REMARK

The length of the lever can be adjusted to 3 stages (positions (A), (B), (C)). To adjust the length, remove the screw at the bottom of the lever knob, slide the knob to the desired position, then tighten the screw again.

(The lever is installed to position (B) when it is shipped from the factory.)

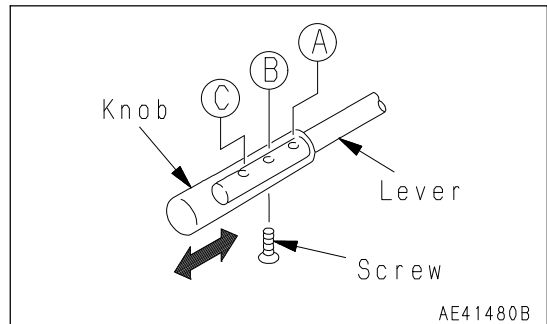

GEARSHIFT LEVER STOPPER

This stopper (3) prevents the gearshift lever from entering the 3rd or 4th positions when working.

Position (a): Stopper actuated.

Position (b): Stopper released.

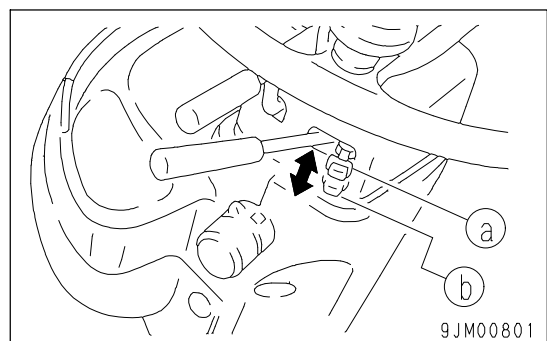

OPERATION

CHECK BEFORE STARTING ENGINE, ADJUST

WALK-AROUND CHECK



WARNING

- Always attach the warning tag to work equipment control lever (1).
- Leakage of oil or fuel, or accumulation of flammable material around high temperature parts, such as the engine muffler or turbocharger, may cause fire. Check carefully, and if any abnormality is found, repair it or contact your Komatsu distributor.

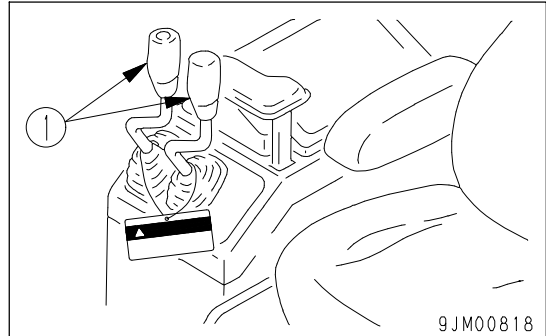

Before starting the engine, walk around the machine and look at the underside of chassis for anything unusual like loose bolts and nuts, leakage of fuel, oil and coolant. Also check the condition of the work equipment and the hydraulic system.

Also check for loose wiring, play, and collection of dust at places that reach high temperature.

Always carry out the items in this section before starting the engine each day.

1. Check for damage, wear, play in work equipment, cylinders, linkage, hoses
Check that there are no cracks, excessive wear, or play in the work equipment, cylinders, linkage, or hoses. If any abnormality is found, repair it.
2. Remove dirt and dust from around engine, battery, radiator
Check if there is any dirt or dust accumulated around the engine or radiator. Check also if there is any flammable material (dead leaves, twigs, grass, etc.) accumulated around the battery or high temperature engine parts, such as the engine muffler or turbocharger. Remove all such dirt or flammable material.
3. Check for leakage of water or oil around the engine.
Check that there is no leakage of oil from the engine or leakage of water from the cooling system. If any abnormality is found, repair it.
4. Check for leakage of oil from the transmission case, axle, hydraulic tank, hoses, or joints
Check that there is no leakage of oil. If any abnormality is found, repair it.
5. Check for leakage of oil from the brake line
Check that there is no leakage of oil. If any abnormality is found, repair it.
6. Check for damage or wear to tires, and loose mounting bolts
Check for cracks or peeling of the tires and for cracks or wear to the wheels (side rim, rim base, lock ring). Tighten any loose wheel nuts. If any abnormality is found, repair or replace the part.
If any valve caps are missing, install new caps.
7. Check for damage to the handrail and steps, loose bolts
Repair any damage and tighten any loose bolts.

(E) Seat height adjustment

Move lever (2) up/down, then move the seat up or down as desired. Since lever (2) is also used for adjusting seat angle, set the seat to the desired height while adjusting the angle.

Adjustment range: 60 mm (2.4 in)

(F) Adjusting headrest height

Move the headrest up or down to the desired height.

Adjustment range: 50 mm (2.0 in)

(G) Adjusting headrest angle

Rotate the headrest to the front or rear.

(H) Adjusting armrest angle

Adjust angle of armrest by rotating knob (5) (left side only).

Adjustment range: 30 degrees (forward tilt: 25 degrees, backward tilt: 5 degrees)

Also, when armrest is turned, it will spring up. (Both left and right sides)

ADJUST SEAT BELT

Always wear the seat belt.

**WARNING**

- Before fastening the seat belt, check that there is no abnormality in the belt-mounting bracket or mounting of the belt. If the belt is worn or damaged, replace it.
- Fasten the seat belt before starting operations.
- Always wear the seat belt during operations.
- Make sure that the left and right belts are not twisted when fastening the seat belt.

FASTENING AND REMOVING BELT

Fasten the belt so that it is tight without being too tight.

1. Sit on the seat, depress the brake pedal fully, and adjust the seat so that your back is pressed against the backrest.
2. After adjusting the seat position, adjust tether belt (1). Tense the tether belt and install it when there is no one sitting on the seat.
3. Sit on the seat, hold buckle (2) and tongue (3) with your left and right hands, insert tongue (3) into buckle (2), then pull the belt to check that it is securely locked.

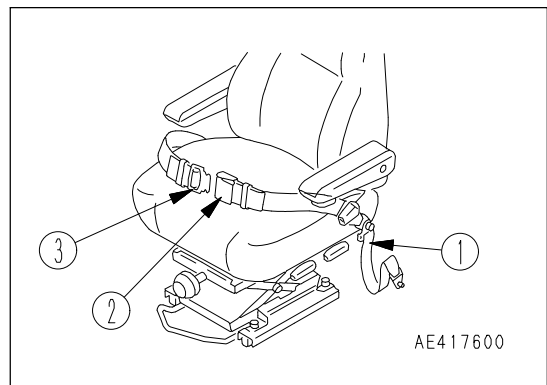

4. When removing the belt, raise the tip of buckle (2) lever to release it. Fasten the belt along your body without kinking it. Adjust the lengths of the belt on both the buckle and the tongue sides so that the buckle is located at the front, mid-point of your body.

MOVING THE MACHINE (DIRECTIONAL, SPEED), STOPPING THE MACHINE

WARNING

- When moving the machine off, check that the area around the machine is safe, then sound the horn before starting.
- Do not allow people to get near the machine.
- Clear the machine's travel path of any obstacle.
- Pay a particular attention to the blind spot at the rear of the machine, when traveling the machine in reverse.

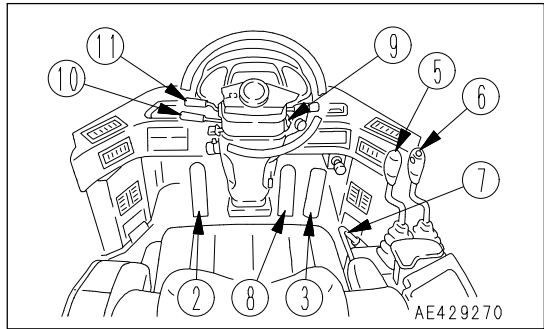

PREPARATIONS FOR MOVING MACHINE

1. Check that caution pilot lamp (4) is not lighted up.

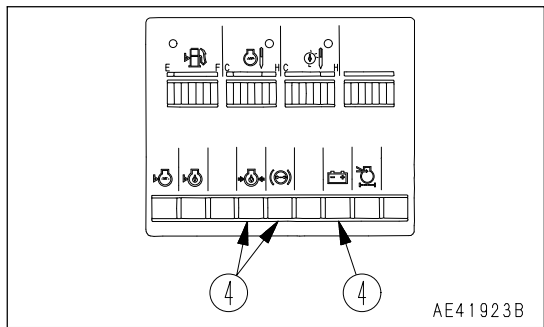

2. Set safety lock lever (7) of bucket control lever (5) and lift arm control lever (6) to the FREE position.

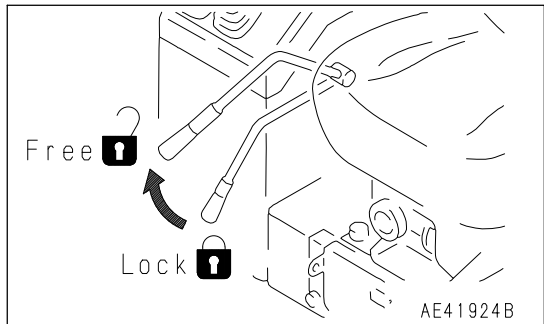

3. Operate lift arm control lever (6) to set the work equipment to the travel posture shown in the diagram on the right.

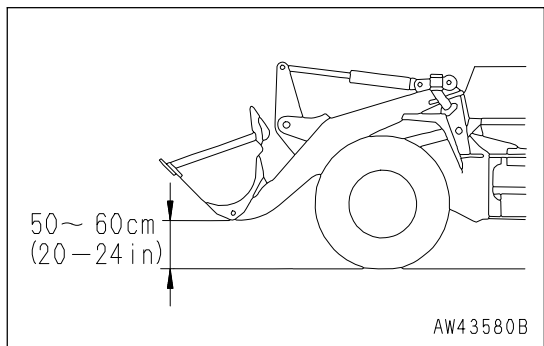

DIGGING AND LOADING ON LEVEL GROUND

- When digging and loading on level ground, set the bucket edge facing down slightly as follows and drive the machine forward. Always be careful not to load the bucket on one side and cause an unbalanced load. This operation should be carried out in 1st gear.

**CAUTION**

Do not set the bucket facing down more than 20 degrees.

1. Set the edge of the bucket facing slightly down.

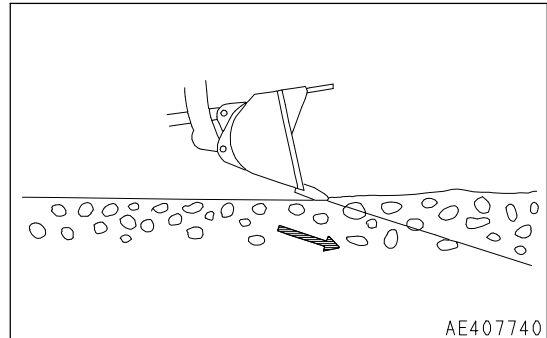

2. Drive the machine forward and operate the lift arm control lever forward to cut a thin layer of the surface each time when excavating the soil.

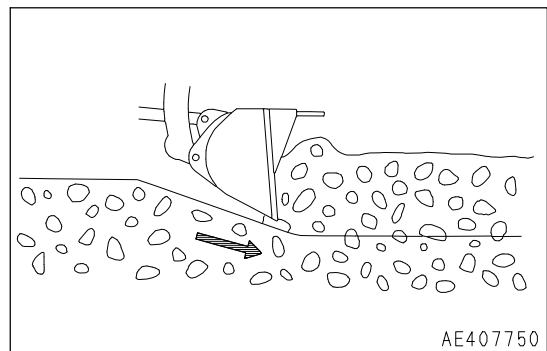

3. Operate the lift arm control lever slightly up and down to reduce the resistance when driving the machine forward.

When digging with the bucket, avoid imposing the digging force on one side of the bucket.

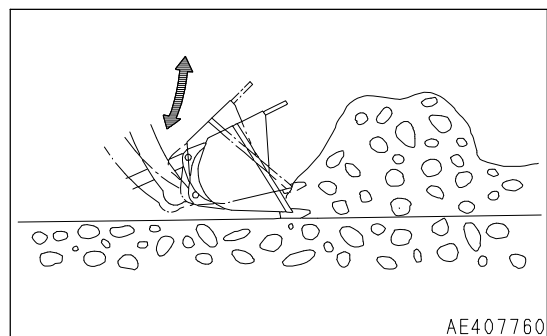

CLICK HERE TO **DOWNLOAD** THE COMPLETE MANUAL

- Thank you very much for reading the preview of the manual.
- You can download the complete manual from: www.heydownloads.com by clicking the link below



- Please note: If there is no response to CLICKING the link, please download this PDF first and then click on it.

CLICK HERE TO **DOWNLOAD** THE COMPLETE MANUAL

INSTALLING THE BUCKET

1. Set cord ring (2) on top of lift arm boss (1) as shown in the diagram.

After completing assembly of the bucket and adjustment with shims in step 8, move the cord ring down to the groove.

2. Coat dust seal lip portion (3) with grease.

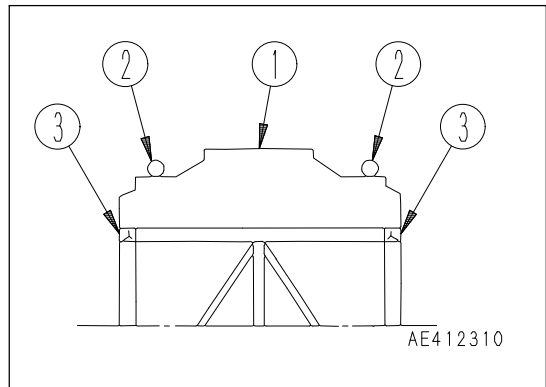

3. Align the left and right bucket pin holes.

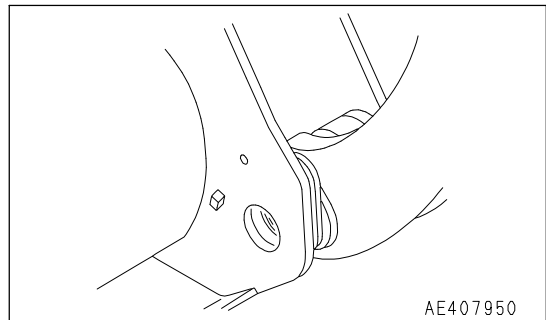

4. Select the number of shims so that clearance A between bucket hinge boss (4) and lift arm boss (1) are less than 1.0 to 1.5 mm (0.04 to 0.06 in).

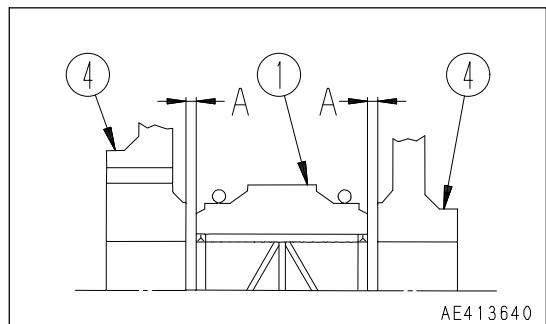

5. Assemble the shims selected in Step 4, align the pin holes, then insert bucket hinge pin (5).

Coat with grease to prevent damage to the dust seal when inserting the bucket hinge pin.

Use a bucket hinge pin that has a grease hole.

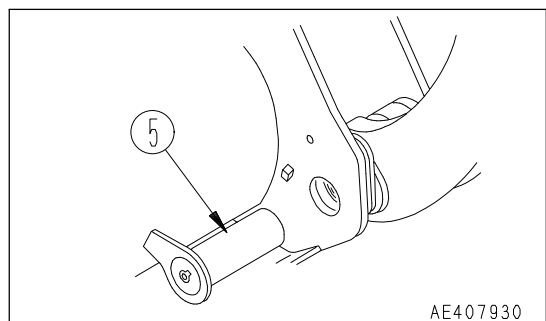

LOCATION OF LIFTING POSITION MARK

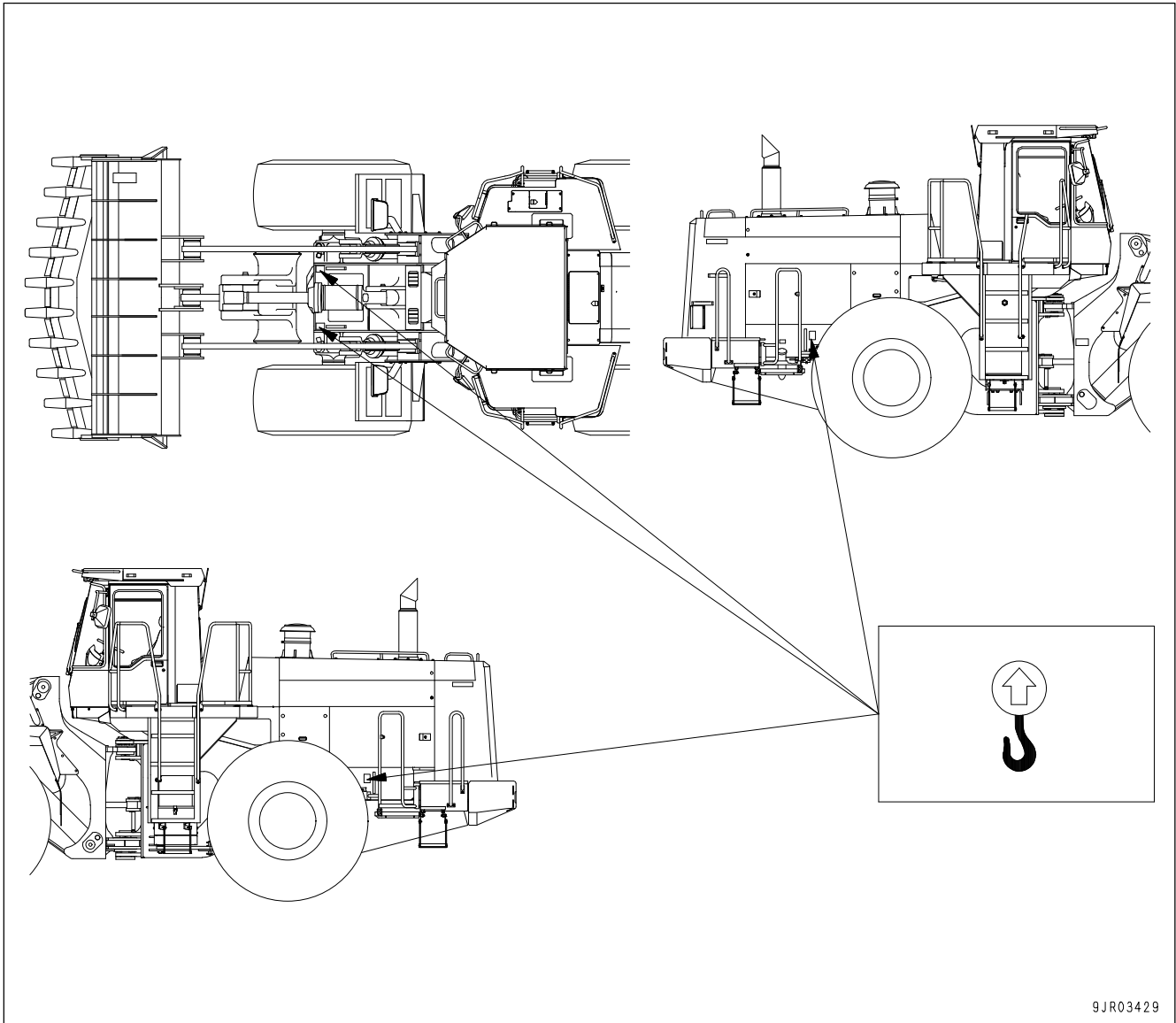

9JR03429

WEIGHT TABLE

	Operating weight	Front wheel load	Rear wheel load	Center of gravity (from front axle)
WA600-3	45180 kg (99622 lb)	21960 kg (48421 lb)	23220 kg (51200 lb)	2110 mm (6 ft 11 in)

IF BATTERY IS DISCHARGED



WARNING

- It is dangerous to charge a battery when installed on a machine. Make sure that it is removed before charging.
- When checking or handling the battery, stop the engine and turn the starting switch key to OFF position.
- The battery generates hydrogen gas, so there is a hazard of explosion. Do not bring lighted cigarettes near the battery, or do anything that will cause sparks.
- Battery electrolyte is dilute sulfuric acid, and it will attack your clothes and skin. If it gets on your clothes or on your skin, immediately wash it off with a large amount of water. If it gets in your eyes, wash it out with fresh water and consult a doctor.
- When handling batteries, always wear safety glasses and rubber gloves.
- When removing the battery, first disconnect the cable from the ground (normally the negative (-) terminal). When installing, install the positive (+) terminal first.
If a tool touches the positive terminal and the chassis, there is danger that it will cause a spark, so be extremely careful.
- If the terminals are loose, there is danger that the defective contact may generate sparks that will cause an explosion.
- When removing or installing the terminals, check which is the positive (+) terminal and which is the negative (-) terminal.

When removing, disconnect the cable from the ground terminal first.

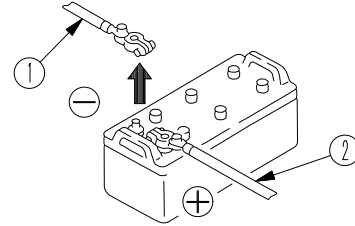

AE42128B

When installing, connect the cable to the positive (+) terminal first.

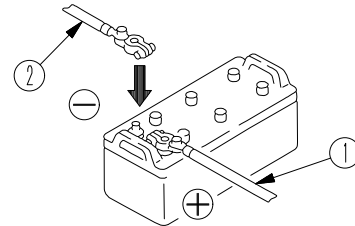

AE42129B

REMOVAL AND INSTALLATION OF BATTERY

- Before removing the battery, remove the ground cable (normally connected to the negative (-) terminal).
If any tool touches between the positive terminal and the chassis, there is a hazard of sparks being generated.
- When installing the battery, connect the ground cable last.

REMARK

The batteries are on both sides at the rear of the machine. The battery used for the ground is on the right side of the machine.

OUTLINES OF SERVICE

- Always use Komatsu genuine parts for replacement parts, grease or oil.
- When changing the oil or adding oil, do not mix different types of oil. When changing the type of oil, drain all the old oil and fill completely with the new oil. Always replace the filter at the same time. (There is no problem if the small amount of oil remaining in the piping mixes with the new oil.)
- Unless otherwise specified, when the machine is shipped from the factory, it is filled with the oil and coolant listed in the table below.

Item	Type
Engine oil pan	Engine oil EO15W40DH (Komatsu genuine parts)
Transmission case	Power train oil TO30 (Komatsu genuine parts)
Hydraulic system	Power train oil TO10 (Komatsu genuine parts)
Axle	Axle oil AXO80 (Komatsu genuine parts)
Radiator	Supercoolant AF-NAC (Density: 30% or above) (Komatsu genuine parts)

HANDLING OIL, FUEL, COOLANT, AND PERFORMING OIL CLINIC

OIL

- Oil is used in the engine and hydraulic equipment under extremely severe conditions (high temperature, high pressure), and deteriorates with use.
Always use oil that matches the grade and maximum and minimum ambient temperatures recommended in the Operation and Maintenance Manual. Even if the oil is not dirty, always change the oil at the specified interval.
- Oil corresponds to blood in the human body, always be careful when handling it to prevent any impurities (water, metal particles, dirt, etc.) from getting in.
The majority of problems with the machine are caused by the entry of such impurities.
Take particular care not to let any impurities get in when storing or adding oil.
- Never mix oils of different grades or brands.
- Always add the specified amount of oil.
Having too much oil or too little oil are both causes of problems.
- If the oil in the work equipment is not clear, there is probably water or air getting into the circuit. In such cases, please contact your Komatsu distributor.
- When changing the oil, always replace the related filters at the same time.
- We recommend you have an analysis made of the oil periodically to check the condition of the machine. For those who wish to use this service, please contact your Komatsu distributor.
- When using commercially available oil, it may be necessary to reduce the oil change interval.
We recommend that you use the Komatsu oil clinic to carry out a detailed checks of the characteristics of the oil.

MAINTENANCE SCHEDULE CHART

MAINTENANCE SCHEDULE CHART

INITIAL 250 HOURS SERVICE (ONLY AFTER THE FIRST 250 HOURS)

REPLACE TRANSMISSION OIL FILTER ELEMENT	4- 47
CHANGE OIL IN HYDRAULIC TANK, REPLACE HYDRAULIC FILTER ELEMENT	4- 56

INITIAL 2000 HOURS SERVICE (ONLY AFTER THE FIRST 2000 HOURS)

CHECK INJECTOR SETTING LOAD, ADJUST	4- 16
---	-------

WHEN REQUIRED

CHECK, CLEAN, OR REPLACE AIR CLEANER ELEMENT	4- 17
CLEAN INSIDE OF COOLING SYSTEM	4- 19
CHECK TRANSMISSION OIL LEVEL, ADD OIL	4- 22
CHECK AXLE OIL LEVEL, ADD OIL	4- 23
CLEAN AXLE CASE BREATHER	4- 24
CLEAN AIR CONDITIONER CONDENSER	4- 24
CHECK WINDOW WASHING FLUID LEVEL, ADD FLUID	4- 25
CLEAN RADIATOR FINS	4- 25
CHECK ELECTRICAL INTAKE AIR HEATER	4- 25
REPLACE BUCKET TEETH	4- 26
LUBRICATING	4- 27
CHECK AIR CONDITIONER	4- 27
REPLACE SLOW BLOW FUSE	4- 28
BLEEDING AIR FROM HYDRAULIC TANK	4- 29
REPLACE FAN BELT, ADJUST AUTO-TENSIONER	4- 29
SELECTION AND INSPECTION OF TIRES	4- 31

CHECK BEFORE STARTING

EVERY 50 HOURS SERVICE

DRAIN WATER, SEDIMENT FROM FUEL TANK	4- 34
--	-------

EVERY 100 HOURS SERVICE

LUBRICATE REAR AXLE PIVOT PIN	4- 35
CHECK OIL LEVEL IN HYDRAULIC TANK, ADD OIL	4- 35
CLEAN ELEMENT IN AIR CONDITIONER FRESH AIR FILTER	4- 36

EVERY 250 HOURS SERVICE

CHECK BATTERY ELECTROLYTE LEVEL	4- 37
CHECK PARKING BRAKE	4- 38
CHECK ALTERNATOR BELT TENSION, ADJUST	4- 39
CHECK AIR CONDITIONER COMPRESSOR BELT TENSION, ADJUST	4- 40
CHECK FOR LOOSE WHEEL HUB NUTS, TIGHTEN	4- 40
CLEAN ELEMENT IN AIR CONDITIONER RECIRCULATION FILTER	4- 41
LUBRICATING	4- 41

CLEAN AXLE CASE BREATHER

Remove all mud and dirt from around the breather with a brush. After removing the mud or dirt from around the breather, remove the breather, immerse it in cleaning fluid and clean it. When cleaning the breather, clean the breathers at two places (front and rear). After removing the breather, take steps to prevent dirt or dust from entering the mount.

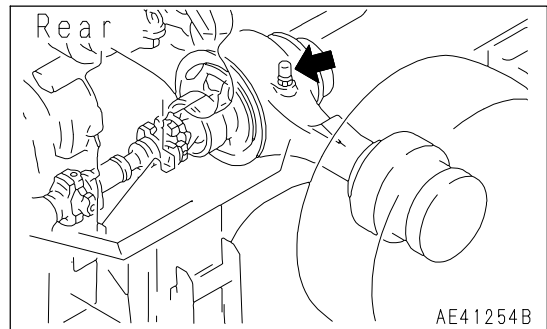
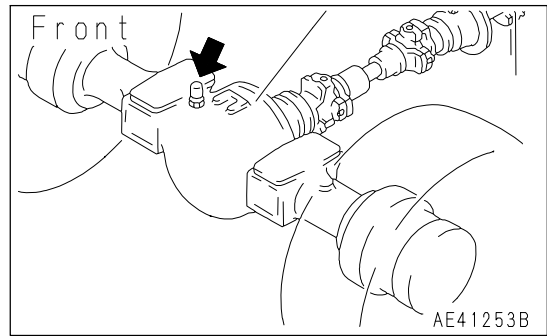

CLEAN AIR CONDITIONER CONDENSER



WARNING

- Do not wash the condenser with a steam cleaner. There is danger that the condenser could overheat.
- If high-pressure water hits your body directly or dirt is sent flying, there is danger of personal injury. Always wear protective glasses, dust mask, and other protective equipment.

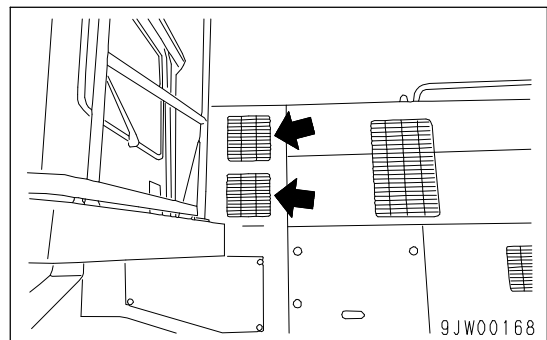

If there is mud or dust on the air conditioner condenser, clean it with water.

If the water pressure is too high, the fins may get deformed. When washing with a high pressure washing machine, apply the water from a reasonable distance.

EVERY 50 HOURS SERVICE**DRAIN WATER, SEDIMENT FROM FUEL TANK**

Loosen valve (1) on the right side of the tank so that the sediment and water will be drained together with fuel.

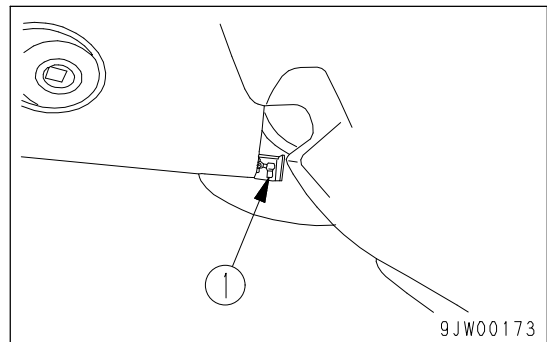

EVERY 500 HOURS SERVICE

Maintenance for every 50, 100 and 250 hours service should be carried out at the same time.

CHANGE OIL IN ENGINE OIL PAN, REPLACE ENGINE OIL FILTER CARTRIDGE



WARNING

- The parts and oil are at high temperature immediately after the engine is stopped, and may cause burns. Wait for the temperature to go down before starting the work.
- When removing the oil filler cap, turn it slowly to release the internal pressure, then remove it.

- Refill capacity: 47 liters (12.4 US gal)
- Prepare a filter wrench

1. Open the engine side cover on the right side of the machine.
2. Open oil filler (F).

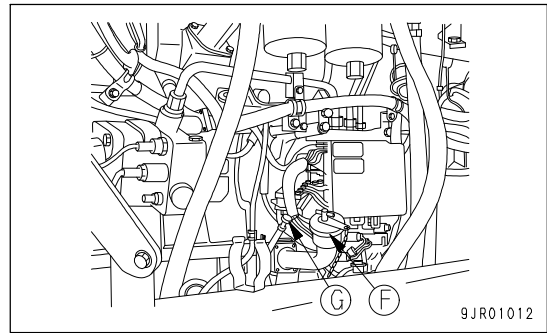

3. Place a container to catch the oil under drain plug (P).
4. Loosen drain plug (P), and drain the oil.
5. Check the drained oil, and if there are excessive metal particles or foreign material, please contact your Komatsu distributor.
6. Install drain plug (P).

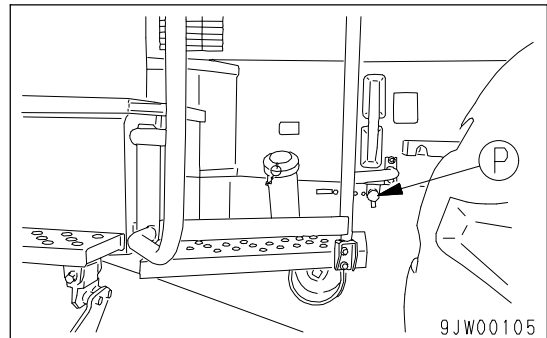

7. Using the filter wrench, turn filter cartridge (1) counterclockwise to remove it.

In particular, if this operation is carried out immediately after stopping the engine, a large amount of oil will come out, so wait for 10 minutes before starting the operation.

8. Clean the filter holder, fill the new filter cartridge with engine oil, then coat the seal and thread of the filter cartridge with engine oil (or coat thinly with grease) and install.
9. When installing, tighten until the packing surface contacts the seal surface of the filter holder, then tighten it 3/4 to 1 turn.

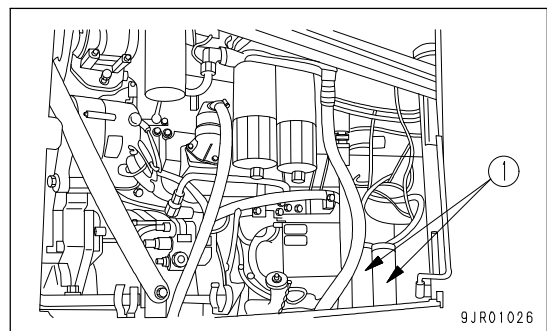

IF BREATHER IS INSTALLED

If the breather is installed at (1) instead of the relief valve, carry out the lubrication according to the following procedure.

1. Supply grease to the parking brake by carrying out steps 1 to 5 of "LUBRICATING PARKING BRAKE (PAGE 4-53)".
2. If the breather is installed at (1), supply grease until the grease is discharged from the breather.

REMARK

Removal of the grease fitting described in steps 6 and 7 of "LUBRICATING PARKING BRAKE (PAGE 4-53)" is not necessary because excessive grease is discharged

3. To discharge the excessive grease completely, repeat applying and releasing of the parking brake at least five times.

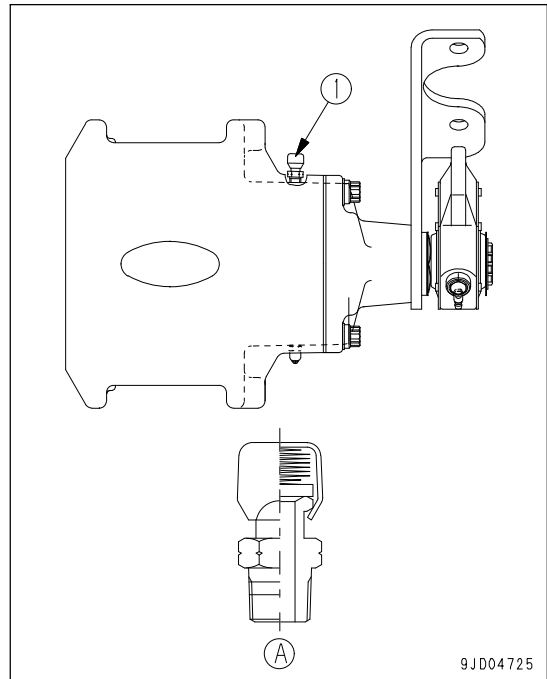

PRECAUTIONS WHEN HANDLING AUTO-GREASING SYSTEM

- Basically, the power source input to the lubrication controller should be DC24V, but use a maximum limit of 30V.
- The grease nipple installed to the service port used for initial charging of the divider valve has a ball check structure, so it may leak if dirt gets stuck in it.
Check it from time to time, and replace the grease nipple immediately if any grease is leaking.
- When carrying out initial operation or when the grease tank is empty, air may get into the piston portion of the pump. If the pressure does not rise within the specified time when running the pump, and an error is displayed for the controller, bleed the air.
- If the divider valve or grease piping are removed when replacing the attachment on the machine, handle carefully to prevent any damage. When storing or installing again, be extremely careful to prevent the entry of air, and particularly dirt. If there is any air in the system, bleed the air immediately.

TROUBLESHOOTING

If any abnormality occurs in the greasing system, the error codes will flash alternately to display the type of abnormality.

Error code	Item	Cause	Remedy
E → a	Defective pressurizing of pump	<ul style="list-style-type: none"> • Air in main piping • Air inside pump • Grease tank is empty • Grease leaking from main piping 	<ul style="list-style-type: none"> • Run pump as necessary and release grease from end of piping to bleed air • Release grease from air bleed in pump to bleed air • Add grease • Check, tighten connections of main piping (including hoses)
E → b	Abnormality in release of pressure	<ul style="list-style-type: none"> • Abnormality in pressure-releasing structure built into pump • Abnormality in pressure-detection equipment built into pump 	<ul style="list-style-type: none"> • Disassemble pressure-releasing portion carefully, then check and clean • Check limit switch at pressure-detection portion
E → c	Abnormality in pressure detection	<ul style="list-style-type: none"> • Abnormality in pressure-detection equipment built into pump • Abnormality in pressure-releasing structure built into pump 	<ul style="list-style-type: none"> • Check limit switch at pressure- detection portion • Disassemble pressure-releasing portion carefully, then check and clean
E → 0	Empty tank	<ul style="list-style-type: none"> • Greasing frequency limit has been reached • Grease added during frequency count 	<ul style="list-style-type: none"> • Add grease • Reset frequency counter to zero. • Confirm that 0 flashes three times on 7-segment LED by pressing reset button on controller for more than 5 seconds.

8. Select the forward or reverse direction of the transmission with FNR button (6) on joystick head (4).

Button N: Neutral

(Transmission is set to the neutral position at the moment when this button is pushed.)

Button F: Forward

(Transmission is set to the forward position at the moment when this button is pushed and released.)

Button R: Reverse

(Transmission is set to the reverse position at the moment when this button is pushed and released.)

9. Turn off joystick ON/OFF switch (5), and the operation of the joystick is turned off.

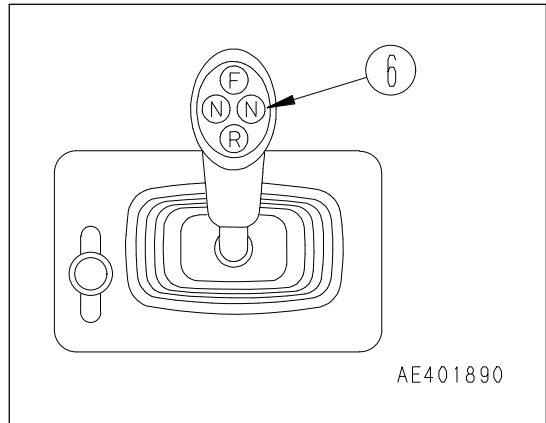

METHOD OF SETTING PRESET BUTTONS

1. Select the desired preset station.
Use the "BAND" button to select MW (AM) or FM, and use the "TUNE" button to select the frequency of the broadcasting station.
2. Decide the number of the button to be preset, and keep it pressed for 2 seconds. The number of the button will be displayed and the presetting is completed.
3. Repeat Steps 1 to 2 to preset other broadcasting stations.
 - To change the setting of a preset switch to another station, repeat Steps 1 to 2.
 - If the battery is replaced or the power is switched off, all the preset settings are deleted. Carry out the presetting operation again.
 - It is possible to preset 6 AM (MW) stations and 6 FM stations.

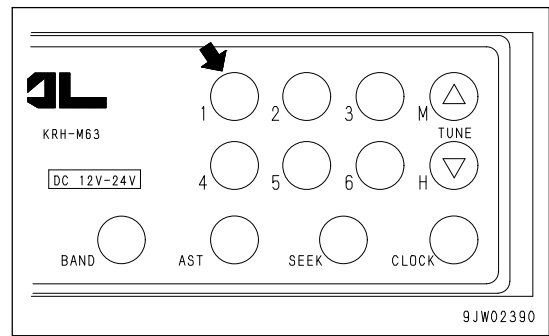

METHOD OF AUTOMATIC MEMORY

If the "AST" button is pressed for 2 seconds, the broadcasting stations that can be received in the area are called up in turn, and the broadcasting stations are automatically saved in the preset memory.

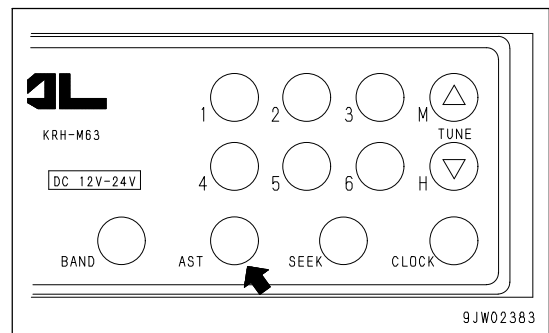

AUTOMATIC SWITCHING RECEPTION OF MONAURAL/STEREO

If the reception of the FM stereo broadcast being received is weak (when you are far from the broadcasting station or are surrounded by hills), the radio is automatically switched from stereo to monaural to reduce the interference. When the stereo broadcast becomes stronger, it automatically switches back to stereo broadcasting.

CLICK HERE TO **DOWNLOAD** THE COMPLETE MANUAL

- Thank you very much for reading the preview of the manual.
- You can download the complete manual from: www.heydownloads.com by clicking the link below



- Please note: If there is no response to CLICKING the link, please download this PDF first and then click on it.

CLICK HERE TO **DOWNLOAD** THE COMPLETE MANUAL