

Operation & Maintenance Manual

WHEEL LOADER

WA470-6

SERIAL NUMBERS 90234 and up

ecot3

⚠ WARNING

Unsafe use of this machine may cause serious injury or death. Operators and maintenance personnel must read this manual before operating or maintaining this machine. This manual should be kept near the machine for reference and periodically reviewed by all personnel who will come into contact with it.

NOTICE

Komatsu has Operation & Maintenance Manuals written in some other languages. If a foreign language manual is necessary, contact your local distributor for availability.

KOMATSU

CLICK HERE TO **DOWNLOAD** THE COMPLETE MANUAL

- Thank you very much for reading the preview of the manual.
- You can download the complete manual from: www.heydownloads.com by clicking the link below



- Please note: If there is no response to CLICKING the link, please download this PDF first and then click on it.

CLICK HERE TO **DOWNLOAD** THE COMPLETE MANUAL

WEAR PARTS LIST -----	4- 8
RECOMMENDED FUEL, COOLANT, AND LUBRICANT -----	4- 9
USE OF FUEL, COOLANT AND LUBRICANTS ACCORDING TO AMBIENT TEMPERATURE ----	4- 10
RECOMMENDED BRANDS, RECOMMENDED QUALITY FOR PRODUCTS OTHER THAN KOMATSU GENUINE OIL -----	4- 11
STANDARD TIGHTENING TORQUES FOR BOLTS AND NUTS -----	4- 12
TORQUE LIST -----	4- 12
PERIODIC REPLACEMENT OF SAFETY CRITICAL PARTS -----	4- 13
MAINTENANCE SCHEDULE CHART -----	4- 15
MAINTENANCE SCHEDULE CHART -----	4- 15
SERVICE PROCEDURE -----	4- 17
INITIAL 250 HOURS SERVICE -----	4- 17
INITIAL 1000 HOURS SERVICE -----	4- 17
WHEN REQUIRED -----	4- 18
CHECK BEFORE STARTING -----	4- 42
EVERY 50 HOURS SERVICE -----	4- 43
EVERY 100 HOURS SERVICE -----	4- 44
EVERY 250 HOURS SERVICE -----	4- 46
EVERY 500 HOURS SERVICE -----	4- 54
EVERY 1000 HOURS SERVICE -----	4- 57
EVERY 2000 HOURS SERVICE -----	4- 62
EVERY 4000 HOURS SERVICE -----	4- 68
EVERY 8000 HOURS SERVICE -----	4- 72
SPECIFICATIONS -----	5- 1
SPECIFICATIONS -----	5- 2
ATTACHMENTS, OPTIONS -----	6- 1
SELECTING BUCKET AND TIRES -----	6- 2
HANDLING TORQUE CONVERTER LOCK-UP -----	6- 3
GENERAL LOCATIONS -----	6- 3
METHOD OF OPERATION -----	6- 4
WARNING/LIMIT FUNCTIONS FOR TRAVEL SPEED -----	6- 5
HANDLING JOYSTICK STEERING SYSTEM -----	6- 6
EXPLANATION OF COMPONENTS -----	6- 6
STRUCTURE AND FUNCTION OF JOYSTICK STEERING -----	6- 10
GETTING IN OR OUT OF OPERATOR'S CAB -----	6- 11
SEAT ADJUSTMENT -----	6- 12
ADJUSTMENT OF JOYSTICK CONSOLE -----	6- 14
OPERATION USING JOYSTICK LEVER AND OPERATION USING STEERING WHEEL -----	6- 15
PRECAUTIONS FOR STEERING WITH JOYSTICK -----	6- 16
OPERATION METHOD OF JOYSTICK STEERING SYSTEM -----	6- 16
HANDLING MULTI FUNCTION MONO-LEVER -----	6- 19
EXPLANATION OF COMPONENTS -----	6- 19
USING FNR SWITCH TO CHANGE BETWEEN FORWARD AND REVERSE -----	6- 24
HANDLING LOAD METER -----	6- 26
OUTLINE OF LOAD METER -----	6- 26
PRINCIPLE OF LOAD METER MEASUREMENT -----	6- 28
POINTS TO REMEMBER TO ENSURE HIGH ACCURACY -----	6- 30
USING LOAD METER -----	6- 32
CENTRAL LUBRICATION SYSTEM -----	6- 63
OPERATING THE CENTRAL LUBRICATION SYSTEM -----	6- 63

(7) Caution when canceling parking brake emergency
(423-93-41311)

 **WARNING**

If the release valve is set to **RELEASE**, a serious accident may occur, as this operation releases the parking brake and the machine body may suddenly start to move.

Never set the release valve to **RELEASE** except when towing the machine in case of machine trouble.

Before towing the machine, carefully read the manual and be sure to follow the instructions given therein.

(8) Warning for hot cooling water (09668-03001)

 **WARNING**

Hot water hazard.

To prevent hot water from spurting out:

- Turn engine off.
- Allow water to cool.
- Slowly loosen cap to relieve pressure before removing.

09668-03001

(9) Caution when oil is at high temperature (09653-03001)

 **WARNING**

Hot oil hazard.

To prevent hot oil from spurting out:

- Turn engine off.
- Allow oil to cool.
- Slowly loosen cap to relieve pressure before removing.

09653-03001

(10) Caution when handling battery cable (09808-03000)

 **WARNING**

Improper use of booster cables and battery cables can cause an explosion resulting in serious injury or death.

- Follow instructions in manual when using booster cable and battery cables.

09808-03000

PRECAUTIONS WHEN LEAVING MACHINE

If the proper procedures are not taken when parking the machine, the machine may suddenly move off by itself, and this may lead to serious personal injury or death. Always do the following.

- When leaving the machine, always lower the work equipment completely to the ground, set work equipment lock lever (1) to the lock position (L), set parking brake switch (2) to the ON position (A), and stop the engine.

In addition, lock all parts, always take the key with you, and leave it in the specified place.

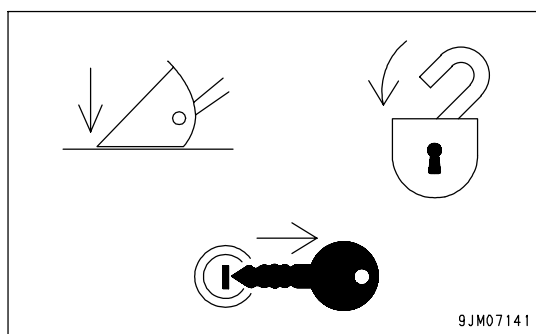
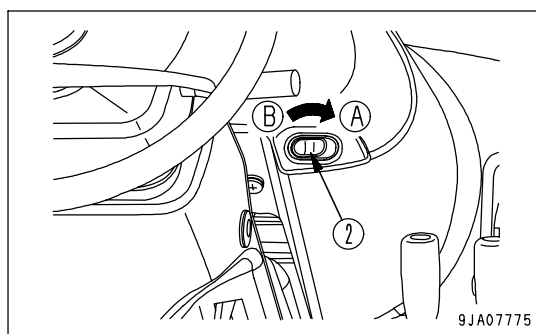
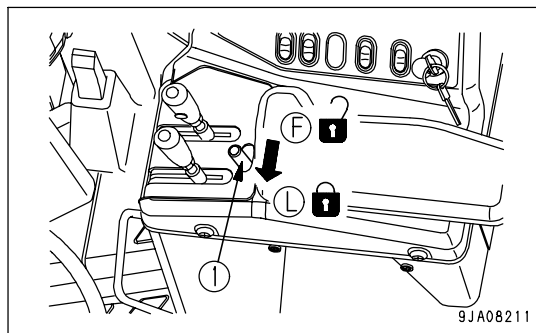
**EMERGENCY EXIT FROM OPERATOR'S CAB**

On machines fitted with a cab, a door is installed on the left side and an emergency escape door is installed on the right side. If the door on the left side does not open, escape from the emergency door on the right side.

PRECAUTIONS WHEN CLEANING CAB GLASS

Always keep the cab glass clean to ensure good visibility when operating.

When cleaning the front glass, pay careful attention to the safety of your footing on the platform on the left or right of the operator's cab or on the step on the front fender so as not to fall off the machine.

For cab glass cleaning procedures, see "WALK-AROUND CHECK (PAGE 3-99)" in this manual.

TRAVELING ON SLOPES

To prevent the machine from tipping over or slipping to the side, always do as follows.

- Keep the work equipment at height (A) 20 - 30 cm (8 - 12 in) above the ground) so that it can be lowered immediately to the ground to stop the machine in case of emergency.

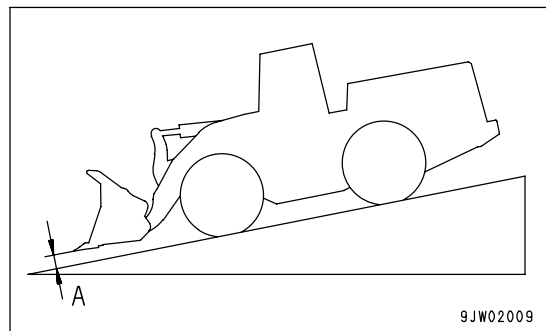
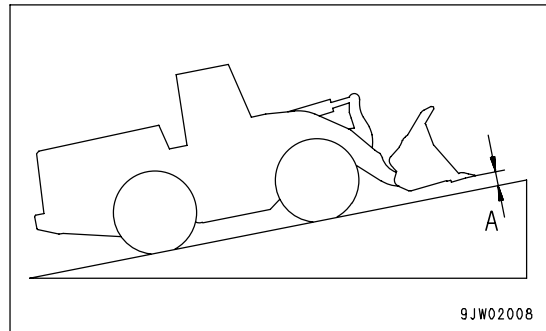

- Always travel straight up or down a slope. Traveling at an angle or across the slope is extremely dangerous.
- Do not turn on slopes or travel across slopes. Always go down to a flat place to change the position of the machine, then travel on to the slope again.

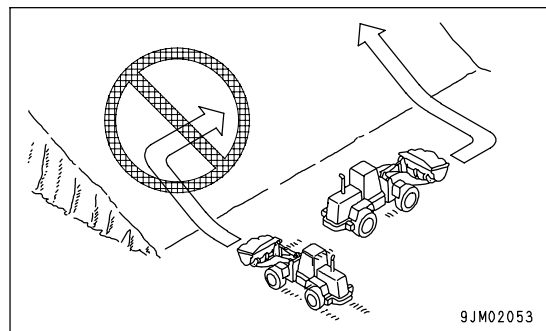

- Travel on grass, fallen leaves, or wet steel plates with low speed. Even with slight slopes there is a hazard that the machine may slip.
- If the engine stops, depress the brake pedal immediately, lower the bucket to the ground, and apply the parking brake to stop the machine.
- When traveling downhill, never shift gear or place the transmission at neutral. It is dangerous not to use the braking force of the engine. Always place the transmission in a low gear before starting to travel downhill.
- When traveling downhill, travel slowly. If necessary, use the braking force of the engine together with the brake pedal to control the travel speed.
- When traveling up or down hills with a loaded bucket, always travel with the bucket facing uphill. If the machine travels with the bucket facing downhill, there is danger that the machine may tip over.

METHOD OF USING BRAKES

- When the machine is traveling, do not rest your foot on the brake pedal. If you travel with your foot resting on the pedal, the brake will always be applied, and this will cause the brakes to overheat and fail.
- Do not depress the brake pedal repeatedly if not necessary.
- When traveling downhill, use the braking force of the engine, and always use the right brake pedal at the same time.
- Set to the lock-up and use the braking force of the engine.

PRECAUTIONS FOR INSPECTION AND MAINTENANCE

PRECAUTIONS WHEN WELDING

Welding operations must always be carried out by a qualified welder and in a place equipped with proper equipment. There is a hazard of gas, fire, or electrocution when carrying out welding, so never allow any unqualified personnel to carry out welding.

HANDLING BATTERY

Before inspecting or handling the battery, turn the key in the starting switch to the OFF position.

- When installing the optional battery disconnecter switch, turn the battery disconnecter switch to the OFF position. For details, see "HANDLING BATTERY DISCONNECTOR SWITCH (PAGE 6-67)".

- **Danger of battery exploding**

When the battery is being charged, flammable hydrogen gas is generated and may explode. In addition, the battery electrolyte includes dilute sulphuric acid. Any mistake in handling may cause serious personal injury, explosion, or fire, so always observe the following.

- Do not use or charge the battery if the battery electrolyte is below the LOWER LEVEL mark. This will cause explosion. Always carry out periodic inspection of the battery electrolyte level, and add distilled water (or commercially available battery filler solution) to the UPPER LEVEL mark.
- Do not smoke or bring any flame close to the battery.
- Hydrogen gas is generated when the battery is being charged, so remove the battery from the machine, take it to a well-ventilated place, remove the battery caps, then carry out the charging.
- After charging, tighten the battery caps securely.

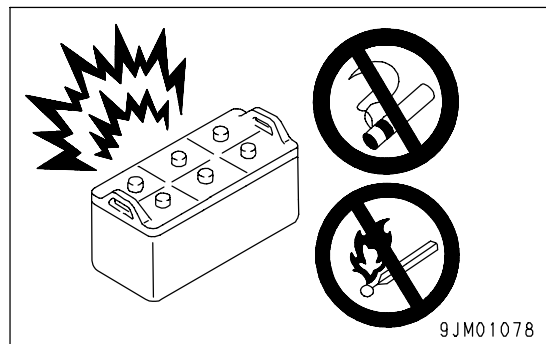

- **Danger from dilute sulphuric acid**

When the battery is being charged, flammable hydrogen gas is generated and may explode. In addition, the battery electrolyte includes dilute sulphuric acid. Any mistake in handling may cause serious personal injury, explosion, or fire, so always observe the following.

- When handling the battery, always wear protective goggles and rubber gloves.
- If battery electrolyte gets into your eyes, immediately wash your eyes with large amounts of fresh water. After that, get medical attention immediately.
- If battery electrolyte gets on your clothes or skin, wash it off immediately with large amounts of water.

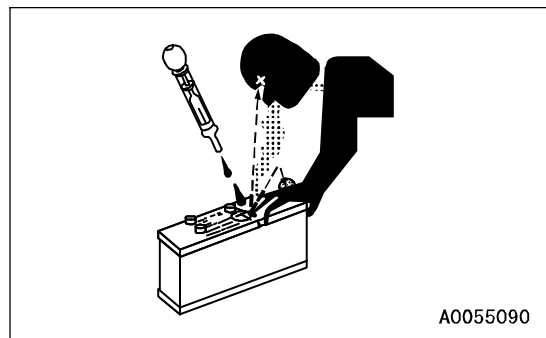

- **Removing battery cables**

Before repairing the electrical system or carrying out electrical welding, turn the starting switch OFF. Wait for approx. 1 minute, then remove the negative (-) battery cable to stop the flow of electricity.

- For machines equipped with a battery disconnecter switch, set the battery disconnecter switch to the OFF position.

For details, see "HANDLING BATTERY DISCONNECTOR SWITCH (PAGE 6-67)".

MACHINE MONITOR

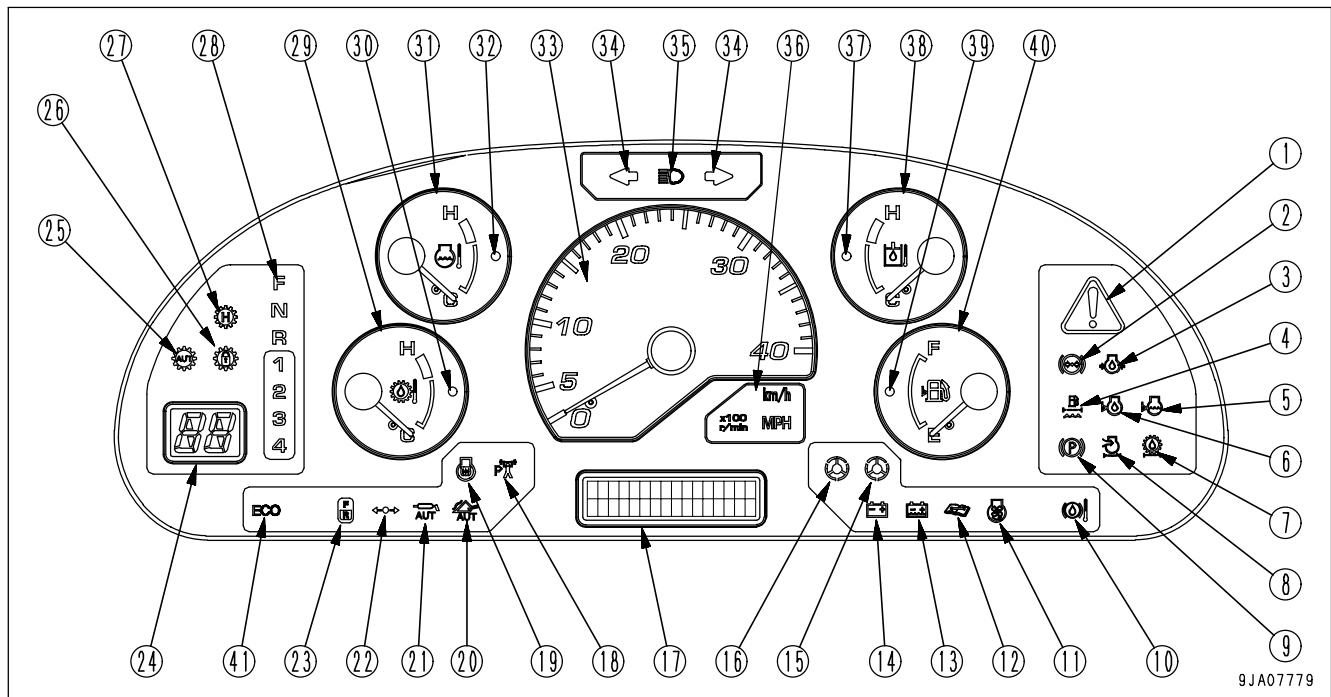

9JA0779

- | | |
|---|---|
| (1) Central warning lamp | (21) Auto-greasing pilot lamp (if equipped) |
| (2) Brake oil pressure caution lamp | (22) Joystick pilot lamp (if equipped) |
| (3) Engine oil pressure caution lamp | (23) Directional selector pilot lamp (if equipped) |
| (4) Water separator caution lamp | (24) Shift indicator |
| (5) Radiator coolant level caution lamp | (25) Auto-shift pilot lamp |
| (6) Engine oil level caution lamp | (26) Torque converter lockup pilot lamp (if equipped) |
| (7) Transmission oil filter clogging caution lamp | (27) Shift hold pilot lamp |
| (8) Air cleaner clogging caution lamp
(Machines equipped with KOMTRAX) | (28) Shift lever position pilot lamp |
| (9) Parking brake pilot lamp | (29) Torque converter oil temperature gauge |
| (10) Brake oil temperature caution lamp | (30) Torque converter oil temperature caution lamp |
| (11) Cooling fan reverse rotation pilot lamp | (31) Engine coolant temperature gauge |
| (12) Maintenance caution lamp | (32) Engine coolant temperature caution lamp |
| (13) Battery electrolyte level caution lamp | (33) Speedometer |
| (14) Battery charge circuit caution lamp | (34) Turn signal pilot lamp |
| (15) Steering oil pressure caution lamp (if equipped) | (35) Head lamp high beam pilot lamp |
| (16) Emergency steering pilot lamp (if equipped) | (36) Meter display pilot lamp |
| (17) Character display portion | (37) Hydraulic oil temperature caution lamp |
| (18) Power mode pilot lamp (P mode) | (38) Hydraulic temperature gauge |
| (19) Preheating pilot lamp | (39) Fuel level caution lamp |
| (20) Semi auto digging pilot lamp (if equipped) | (40) Fuel gauge |
| | (41) Economy operation display lamp |

EMERGENCY STOP ITEMS

CAUTION

If these lamps light up and the buzzer sounds, stop operations immediately and carry out inspection and maintenance of the applicable location.

If any abnormality is found in the emergency stop items, the alarm buzzer will sound intermittently, and the lamp for the location of the abnormality and the central warning lamp will light up.

At the same time, the top line of the character display displays "E03" and the bottom line displays "CHECK RIGHT NOW" and "CALL" alternately for 3 seconds each, so stop the machine immediately in a safe place, stop the engine, and carry out inspection.

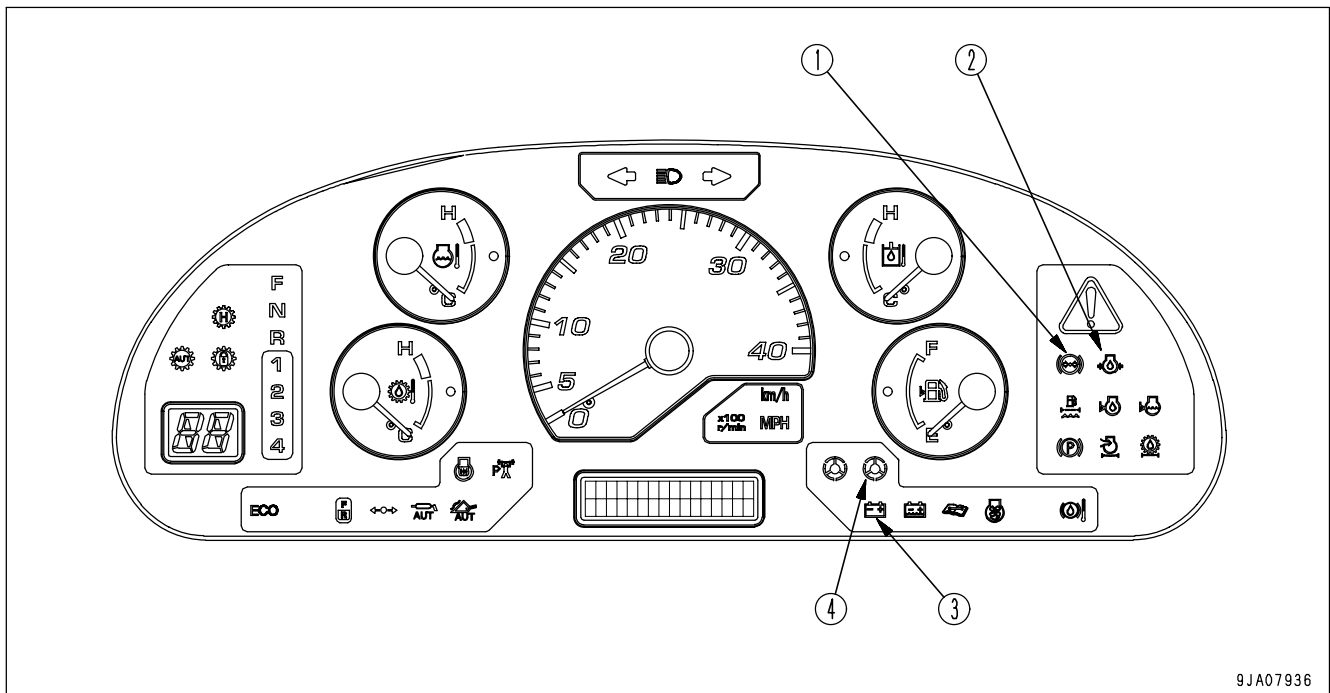

9JA07936

- | | |
|---|---|
| (1) Brake oil pressure caution lamp | (4) Steering oil pressure caution lamp
(if equipped) |
| (2) Engine oil pressure caution lamp | |
| (3) Battery charge circuit caution lamp | |

COOLING FAN REVERSE ROTATION PILOT LAMP

This lamp (2) lights up when the direction of rotation of the cooling fan is reversed.

At the same time, "COOLING FAN REVERSE" is displayed on the character display.

For details of the method of operation, see "COOLING FAN REVERSE ROTATION SWITCH (PAGE 3-50)".

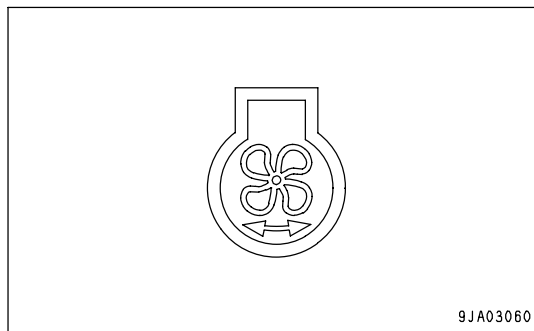
**EMERGENCY STEERING PILOT LAMP**

(If equipped)

(Green)

This lamp (3) lights up when the emergency steering is being actuated.

If the engine stops when the machine is traveling or an abnormality occurs in the steering oil pressure circuit, and the machine is traveling at a speed of more than 2 km/h (1.2 MPH), the emergency steering is automatically actuated and the lamp lights up.

If the lamp lights up, move the machine immediately to a safe place, stop the engine, and check the condition.

In addition, the lamp flashes if the emergency steering is actuated continuously for one minute.

At the same time, "E02 EMR S/T OVERRUN" is displayed on the character display, so move the machine immediately to a safe place, stop the engine, and check the condition.

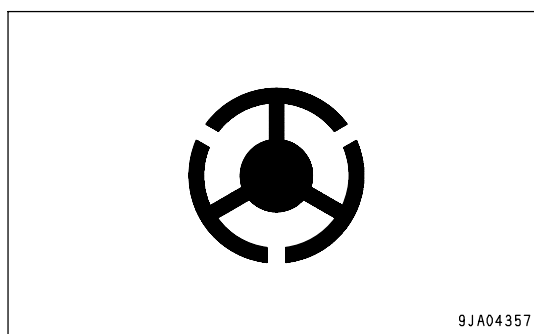

There is an emergency steering self-check function. For details, see "EMERGENCY STEERING SELF-CHECK FUNCTION (PAGE 3-137)" in the OPERATION section.

POWER MODE PILOT LAMP (P MODE)

This lamp (4) lights up when the P mode is selected.

Use the power mode selector switch to select the P mode.

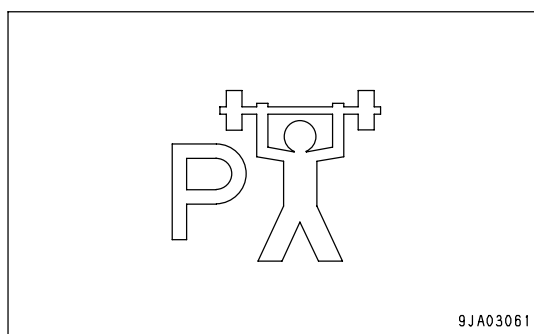

INPUT METHOD FOR TELEPHONE NUMBER

It is possible to display the telephone number on the right side of "CALL" displayed on the character display when action code "E03" is generated.

1. Press the (◇) of machine monitor mode selector switch 1, and display the odometer.
2. Press (>) or (<) of machine monitor mode selector switch 2 and display "TEL".

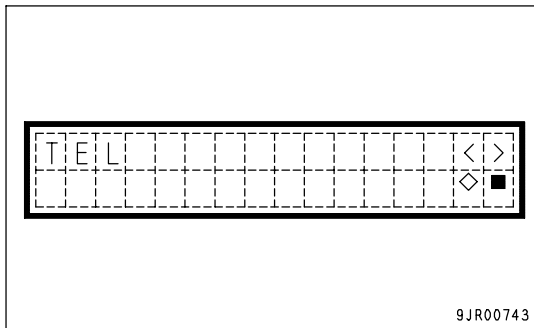

3. Press (◇) of machine monitor mode selector switch 1. It will change to the display in the diagram on the right.

Once the telephone number is input, the input number will be displayed next time.

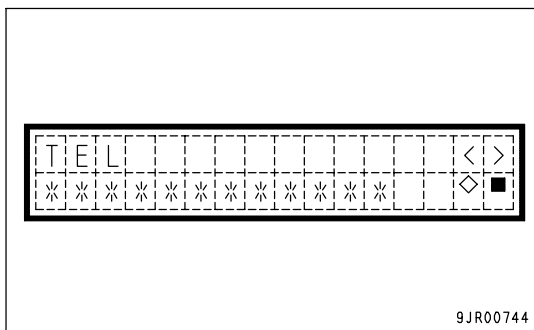

4. Up to 12 digits can be displayed for the telephone number. Input from the first digits.
The cursor is displayed at the input position. Press (>) or (<) of machine monitor mode selector switch 2 and display "0 to 9". To leave a blank, select "*".
When the input value is decided, press (◇) of machine monitor mode selector switch 1. The cursor will move to the next position.
5. Repeat the procedure in Step 4 until the last digit. At the last digit, press (◇) of machine monitor mode selector switch 1 to return to the previous screen.
If there is a mistake in the input or the input is to be stopped, press (■) of machine monitor mode selector switch 1 to return to the previous screen.
6. When completing the operation, press (■) of machine monitor mode selector switch 1 twice or turn the starting switch OFF.

HAZARD LAMP SWITCH

**WARNING**

Use the hazard lamp only in emergencies. Using the hazard lamp when traveling may cause confusion for other machine operators.

This switch (8) is used in emergencies, such as when the machine breaks down and has to be parked on the road.

Position (A): Turn signal lamps, turn signal pilot lamp flash, and pilot lamp (C) lights up at same time.

Position (B): Lamps are OFF.

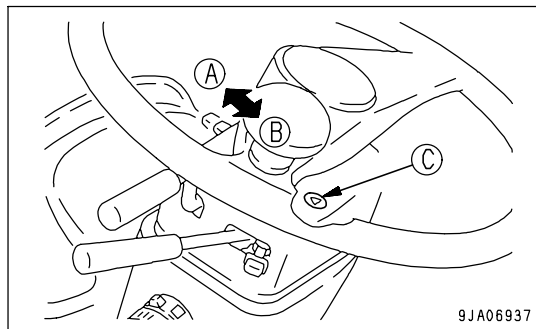

9JA06937

PARKING BRAKE SWITCH

**WARNING**

Always apply the parking brake when leaving the machine or when parking it.

Even if the parking brake switch is turned ON, there is danger until the parking brake pilot lamp lights up, so keep the brake pedal depressed.

NOTICE

- Do not use the parking brake switch to apply the brake when traveling except in emergencies. The parking brake may be damaged, resulting in a serious accident. Stop the machine first, then apply the parking brake.
- If the parking brake has to be used as an emergency brake when the machine is traveling at high speed, ask your Komatsu distributor to carry out inspection to check that there is no damage to the parking brake.

This switch (9) operates the parking brake.

Position (A): ON

The parking brake is applied, and the parking brake pilot lamp lights up.

Position (B): OFF

The parking brake is released.

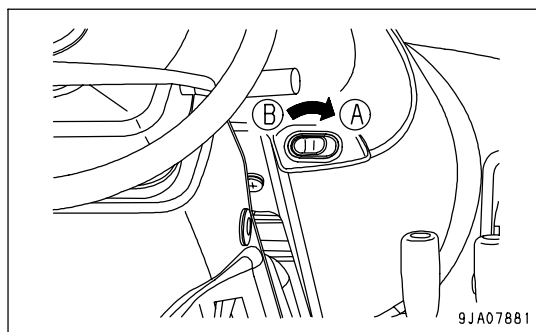

9JA07881

REMARK

- When the parking brake is applied, the machine will not move off even if the directional lever is operated.
- If the directional lever is placed at the F or R position with the parking brake still applied, the central warning lamp will light up and the buzzer will sound.
- Before starting the engine, turn the parking brake switch ON.

CONTROL LEVERS, PEDALS

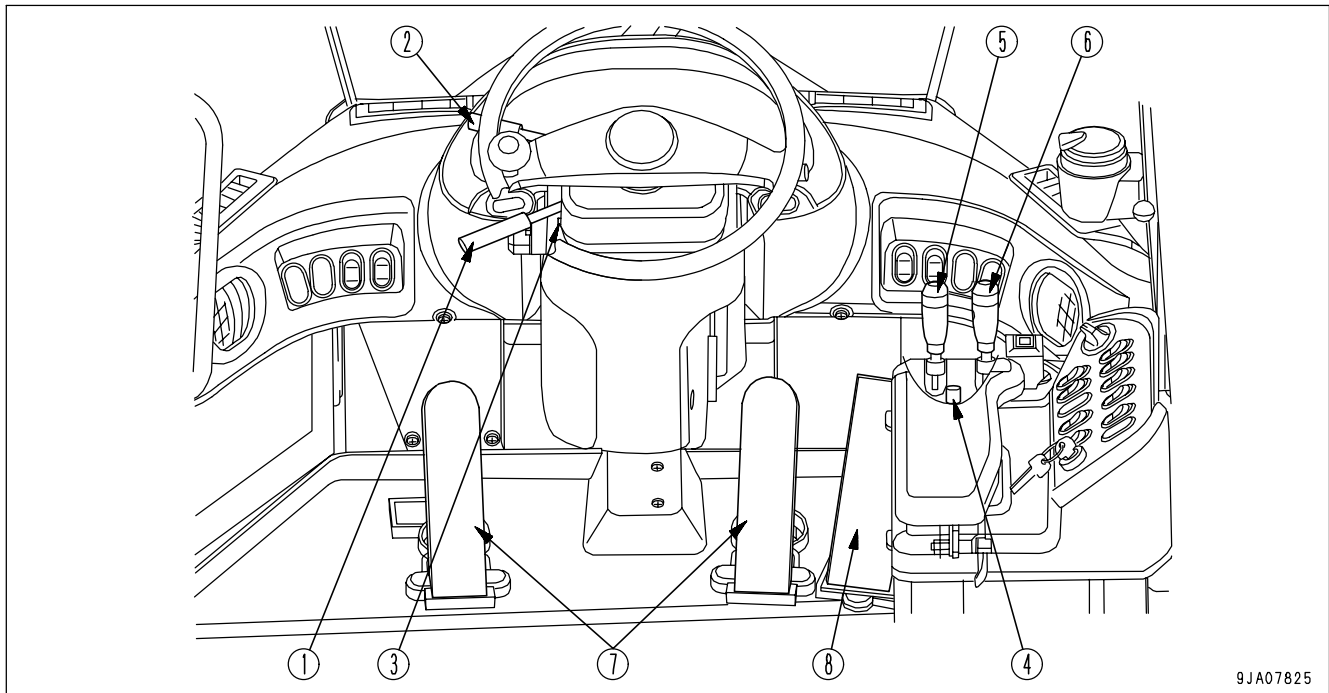

9JA07825

- | | |
|-------------------------------|----------------------------|
| (1) Gearshift lever | (5) Bucket control lever |
| (2) Directional lever | (6) Lift arm control lever |
| (3) Gearshift lever stopper | (7) Brake pedal |
| (4) Work equipment lock lever | (8) Accelerator pedal |

GEARSHIFT LEVER

This lever (1) changes the speed range of the transmission.

MANUAL SHIFT

This machine has a 4-FORWARD, 4-REVERSE speed transmission.

Place the gearshift lever in a suitable position to obtain the desired speed range.

1st and 2nd speeds are used for working.

3rd and 4th speeds are used for traveling.

However, when the gearshift lever stopper is being used, it is impossible to shift to 3rd or 4th. Disengage the gearshift lever stopper before trying to shift gear.

Position (a): 1st

Position (b): 2nd

Position (c): 3rd

Position (d): 4th

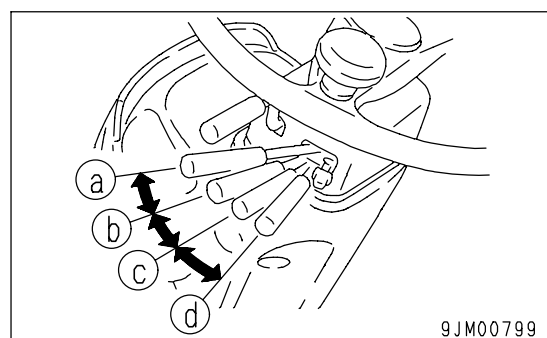

9JM00799

OPEN LOCK KNOB FOR CAB EMERGENCY ESCAPE DOOR

CAUTION

- The door on the right side of the cab is provided as an emergency escape door for use when it is impossible to exit from the door on the left side. Do not use it as the door for normal entry and exit from the cab.
- Never operate the machine with the door open to around 90 degrees. The door may extend beyond the maximum width of the machine or it may suddenly close if the brakes are applied. This is extremely dangerous, so never operate the machine in this condition.
- Operate the machine with the door on the right side fully closed (lock) or partially opened (quarter lock).

Use this to fix the door on the right side at the open or closed position.

1. When open lock knob (1) is pushed down securely, the lock is applied.

When using the air conditioner or heater, carry out operations with the knob in this position.

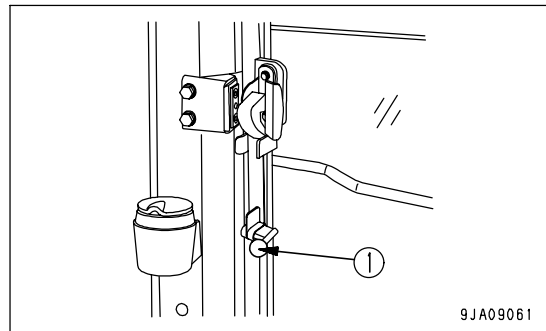

2. If open lock knob (1) is lifted up, the door on the right will partially open (quarter lock).

When taking in outside air on the right side, carry out operations with the window in this position.

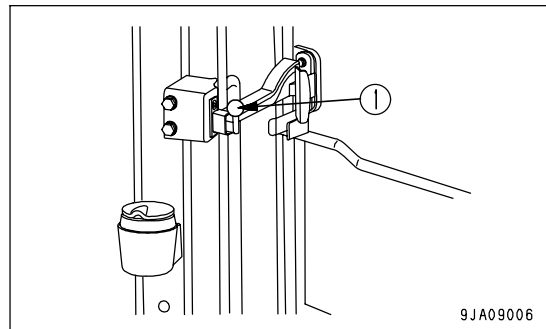

METHOD OF RELEASING A LOCK IN AN EMERGENCY

If the door on the left side of the cab will not open, or it is dangerous to get on or off the machine from the door on the left side, release the open lock of the door on the right, open the door fully, then use it to leave the operator's cab.

1. Lift open lock knob (1) up.

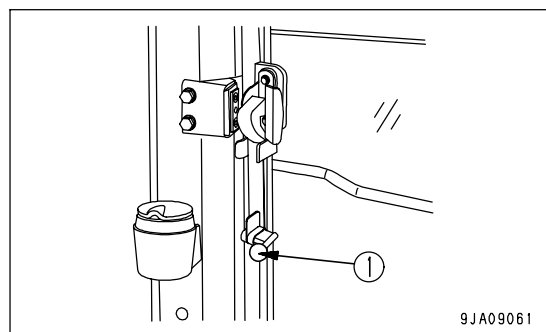

METAL TAPE BUTTON

(used also for preset button No. 5)

This button (11) is used when playing a metal or chrome tape. This button is also used for preset button No. 5. When it is pressed, "MTL" appears on the display.

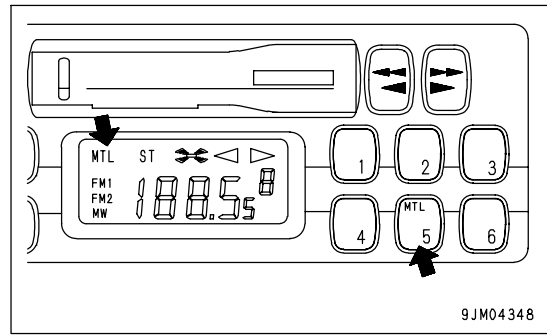

MANUAL TUNING BUTTONS

These buttons (12) are used for manual tuning.

When "TUN ^" button is pressed, the frequency goes up; when "TUN v" button is pressed, the frequency goes down. If the button is pressed down and held, the frequency will change continuously.

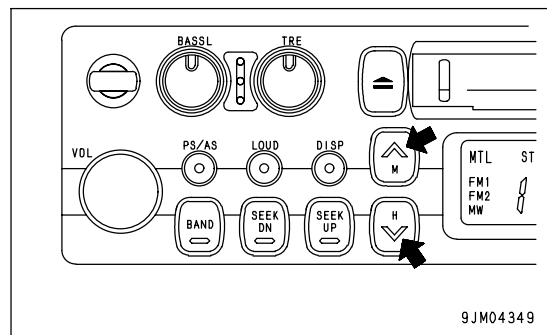

SEEK TUNING BUTTONS

These buttons (13) are used to seek tuning.

When the "SEEK UP" button is pressed, the search automatically goes up; when the "SEEK DN" button is pressed, the search automatically goes down.

When the next station that can be received is found, it automatically stops.

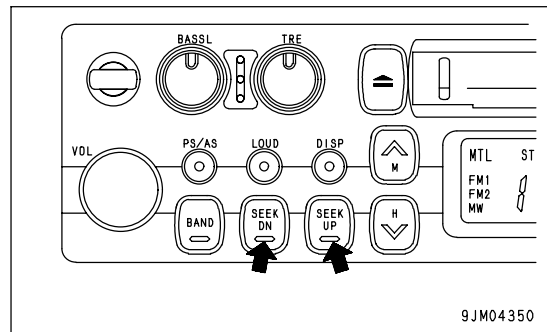

BAND SELECTOR BUTTON

When this button (14) is pressed, the band is switched between FM1, FM2, and MW (AM). The band is shown on the display.

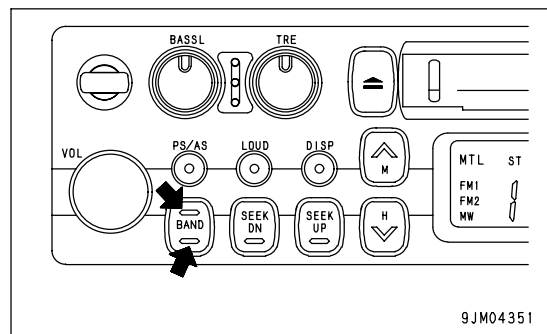

AIR CONDITIONER

(If equipped)

By taking fresh air into the cab through a filter, it is possible to raise the pressure inside the cab. This makes it possible to provide a pleasant working environment even on dusty jobsites.

GENERAL LOCATIONS AND FUNCTION OF CONTROL PANEL

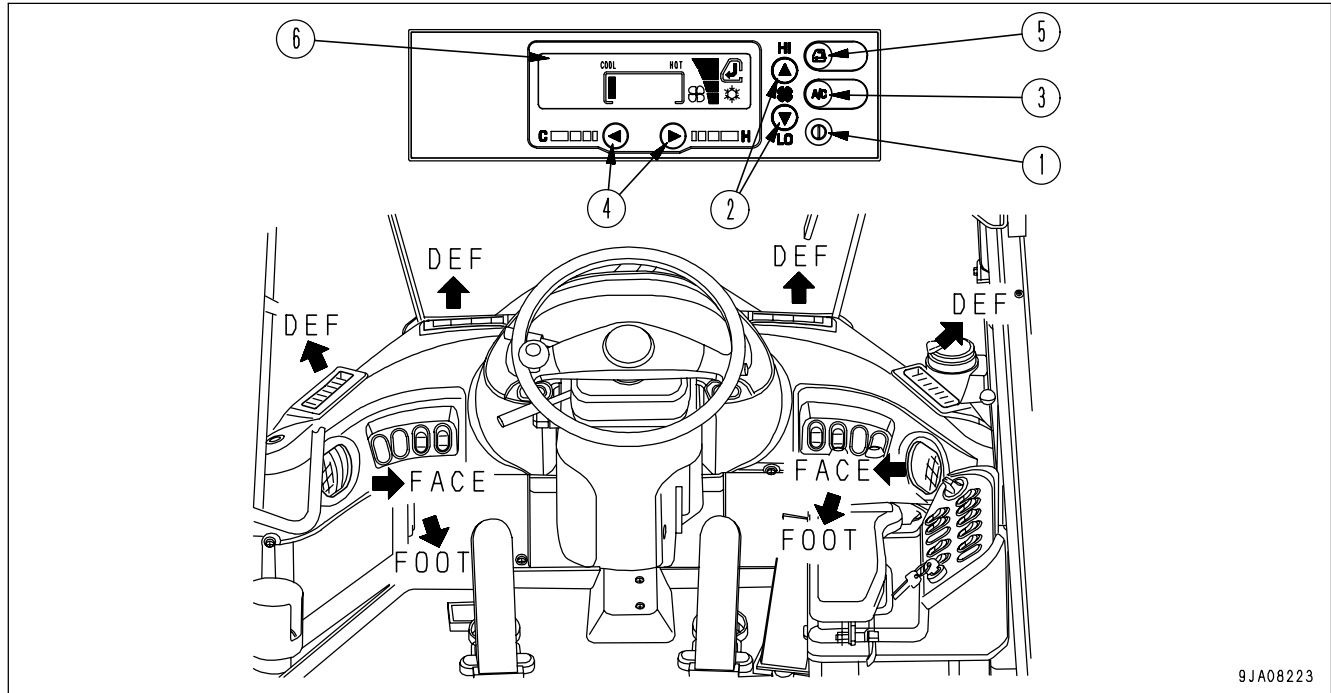

9JA08223

- | | |
|----------------------------|----------------------------------|
| (1) Main power switch | (4) Temperature control switch |
| (2) Fan switch | (5) FRESH/RECIRC selector switch |
| (3) Air conditioner switch | (6) Display monitor |

AIR CONDITIONER SWITCH

Use this switch (3) to start and stop the cooling or dehumidifying heating function.

When the main power switch is ON, if the air conditioner switch is pressed, the air conditioner is turned ON and (A) is displayed on the display monitor.

If the switch is pressed again, the switch is turned OFF and display monitor (A) goes out.

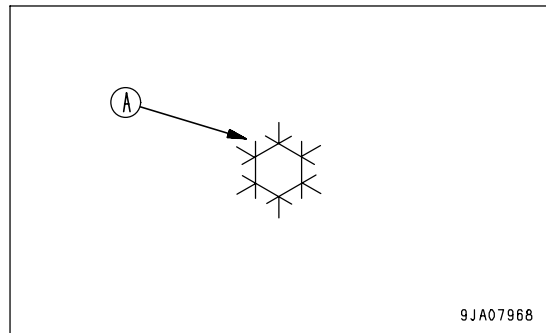
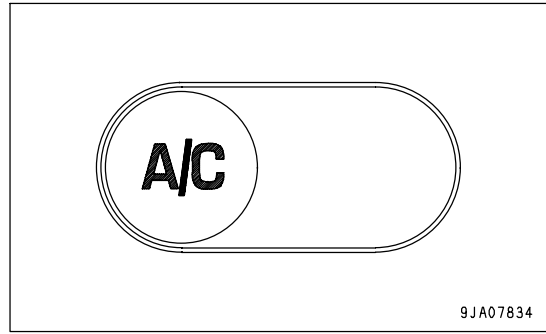

AUTO SWITCH

Use this switch (4) for automatic operation of the air conditioner (actuation of the cooling and dehumidifying/heating functions, stopping operation).

When the main power switch is turned ON and the AUTO air conditioner switch is pressed, the air conditioner is turned ON and the display monitor shows "AUTO".

If the switch is pressed again, the air conditioner is turned OFF and the "AUTO" sign on the display monitor goes out.

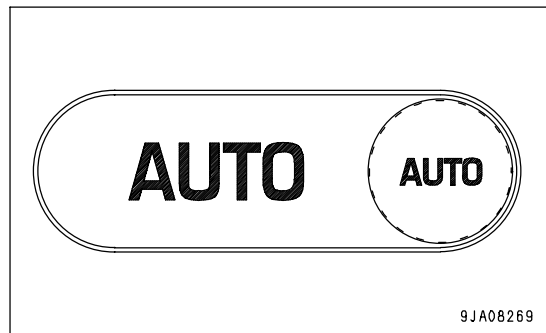

TEMPERATURE CONTROL SWITCH

Use this switch (5) to adjust the temperature between low temperature and high temperature.

When switch (A) is pressed, the temperature of the air blowing out becomes higher; when switch (B) is pressed, the temperature of the air blowing out becomes lower.

The set temperature is displayed on the display monitor.

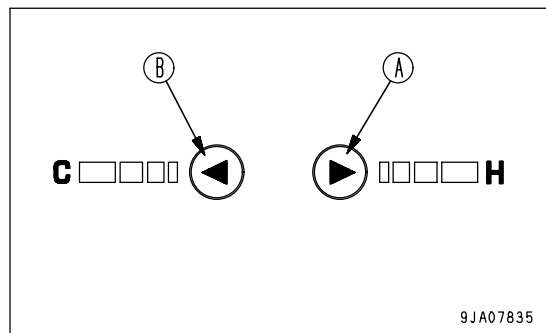

CHECK COOLANT LEVEL, ADD COOLANT

 **WARNING**

- Do not open the radiator cap unless necessary. When checking the coolant, always wait for the engine to cool down and check the sub-tank.
- Immediately after the engine is stopped, the coolant is at a high temperature and the radiator is under high internal pressure. If the cap is removed to check the coolant level in this condition, there is a hazard of burns. Wait for the temperature to go down, then turn the cap slowly to release the pressure and remove it carefully.

 **CAUTION**

When adding coolant, use the step and handrail provided. Support your body securely.

1. Open cover (1) of the platform on the right side of the machine.
2. Check that the coolant level is between the FULL and LOW marks on radiator sub-tank (2). If the coolant level is low, add coolant through the coolant filler of sub-tank (2) to the FULL level.
3. After adding coolant, tighten the cap securely.
4. If the sub-tank becomes empty, there is probably coolant leakage. After checking, repair any abnormality immediately. If no abnormality is found, check the level of the water in the radiator. If it is low, add COOLANT of the same density in radiator according to the COOLANT density table in "CLEAN INSIDE OF COOLING SYSTEM (PAGE 4-21)", then add COOLANT to the sub-tank.

If the volume of coolant added is more than usual, check for possible leakage.
Confirm that there is no oil in the coolant.

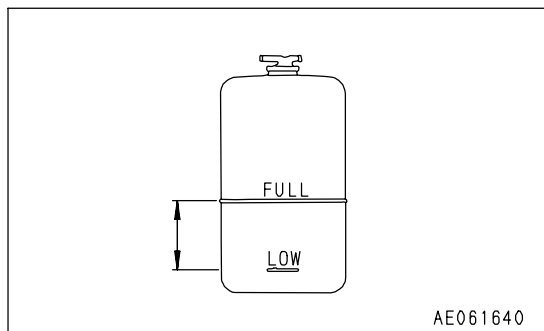
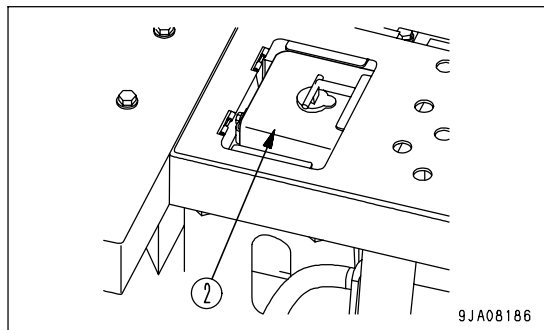
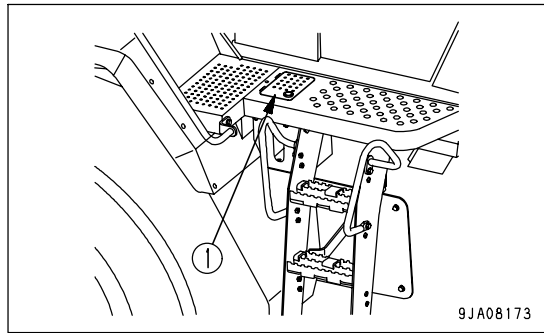

To make belt longer: Set the fixed end of the tether belt at 90 degrees to the holder, and pull.

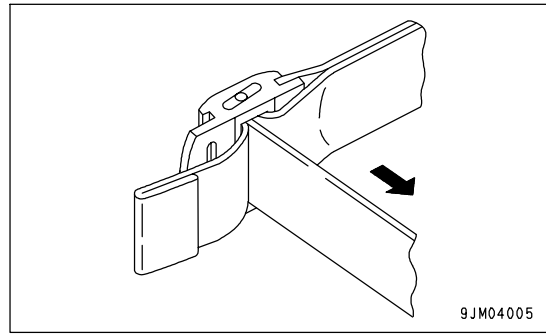

ADJUST LEVER STAND

! WARNING

When adjusting the lever stand, check that the work equipment lock lever is securely at the LOCK position. If it is not at the LOCK position, and the work equipment control levers are touched by accident when adjusting the lever stand, the work equipment may suddenly move and cause serious personal injury.

ADJUST HEIGHT AND ANGLE OF ARMREST

The height and angle of armrest (1) can be adjusted by loosen lock lever (2).

Height adjustment amount: 30 mm

Angle adjustment amount: 44 degrees

REMARK

Set lock lever (2) to the FREE position (F). The lock lever is loosened.

Hold the armrest at the desired position and move the lock lever to the LOCK position (L) to secure the armrest in position.

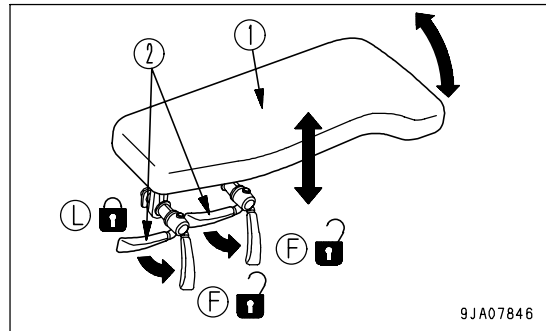

ADJUST LEVER STAND FORWARD AND BACKWARD

Pull lever (3) up with your left hand, grip armrest (1) with your right-hand and move it to the front or rear, then release lever (3).

Amount of adjustment: 180 mm

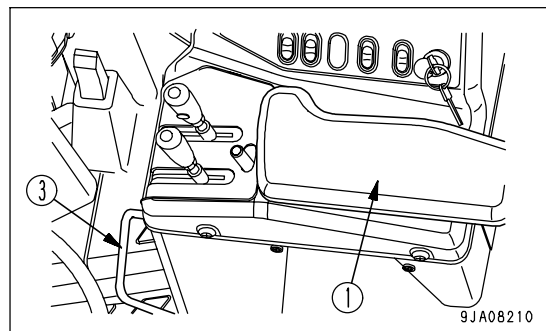

To warm up the hydraulic oil in cold areas, do as follows.

- 2. After carrying out the warming-up operation, check that the engine rotation is smooth, then set the work equipment lock lever to the FREE position (F).
- 3. Operate the bucket control lever to the TILT position (A) and return it to the HOLD position (B) repeatedly to warm up the hydraulic oil.

Relieve the circuit at the TILT position (A) for a maximum of 10 sec.

This brings the oil to the relief pressure and makes it quicker warm up the oil.

- 4. Slowly operate the steering wheel to the left and the right about 10 times to warm up the hydraulic oil inside the steering valve.

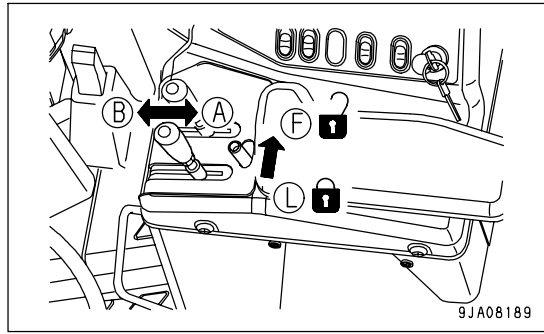

9JA08189

! WARNING

If the steering wheel is operated and stopped while the oil temperature is low, there may be a time lag before the machine stops turning. In this case, use the frame lock bar to ensure safety, and perform the warm-up operation in a wide place. Do not relieve the hydraulic oil in the circuit continuously for more than 5 seconds.

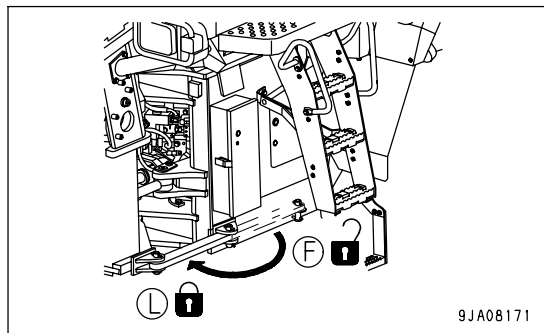

9JA08171

NOTICE

Turn the steering wheel a little and stop in that position. Confirm that the machine turns by an angle equivalent to the amount that the steering wheel is turned.

- 5. After carrying out the warming-up operation, check that the gauges and caution lamps are normal. If there is any abnormality, carry out maintenance or repair. Run the engine under a light load until engine water temperature gauge (2) and torque converter oil temperature gauge (3) are in the green range.
- 6. Check for abnormal exhaust gas color, noise, or vibration. If any problem is found, contact your Komatsu distributor.

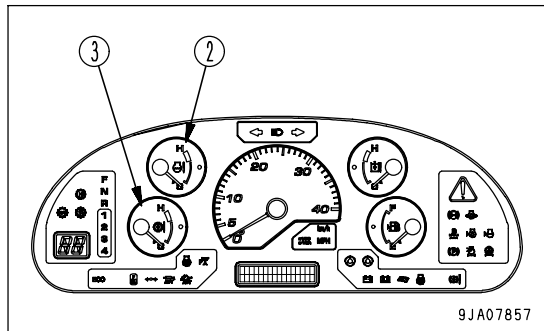

9JA07857

REMARK

The rotating speed of the cooling fan differs according to the following conditions, but this does not indicate any abnormality.

The cooling fan speed increases when the hydraulic oil temperature, engine coolant temperature, or transmission oil temperature are high.

However, when the cooling fan is rotating in reverse, it rotates at a fixed speed proportional to the engine speed, regardless of any oil or coolant temperature.

ADJUSTING TRANSMISSION CUT-OFF POSITION



CAUTION

Apply the parking brake before adjusting the transmission cut-off position.

Adjust the amount that the brake pedal is depressed.

1. Start the engine with starting switch (1), then set parking brake switch (2) to the ON position.
2. Set transmission cut-off switch (3) to the ON position.
3. Depress brake pedal (4) and adjust the set position to return the transmission to Neutral.

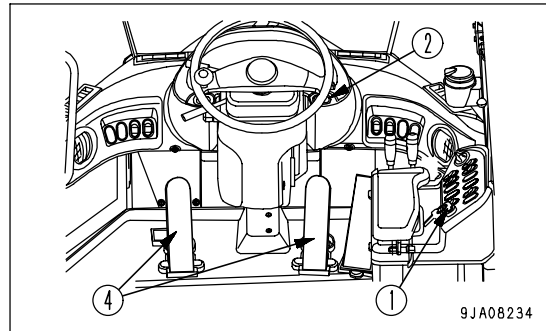

4. Press transmission cut-off set switch (5), then release it. When the switch is released, the buzzer will sound with a repeated short sound, and the cut-off position is set.

Method of canceling cut-off position

5. After the buzzer sounds in Step 4 of the adjustment procedure, the transmission cut-off switch flashes for 2 seconds. While it is flashing, press transmission cut-off set switch (5) again and release it.
6. The buzzer will sound with a long sound and the adjusted cut-off position is canceled.

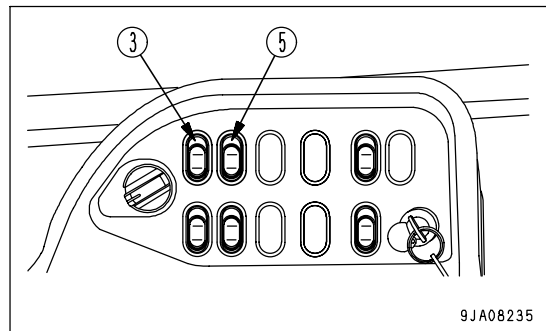

STOPPING WHEN TRANSMISSION CUT-OFF IS ON

When the transmission cut-off switch is ON, if the brake pedal is depressed, the transmission is returned to Neutral when the brake pedal is depressed to the set position.

REMARK

When the transmission cut-off switch is OFF, the transmission is not returned to Neutral.

CLICK HERE TO **DOWNLOAD** THE COMPLETE MANUAL

- Thank you very much for reading the preview of the manual.
- You can download the complete manual from: www.heydownloads.com by clicking the link below



- Please note: If there is no response to CLICKING the link, please download this PDF first and then click on it.

CLICK HERE TO **DOWNLOAD** THE COMPLETE MANUAL

LOADING OPERATIONS

Select the method of operation which will give the minimum amount of turning and travel in order to provide the most efficient method for the jobsite.



WARNING

- Always keep the jobsite flat, and do not operate the steering wheel suddenly or apply the brakes suddenly when the lift arm is raised with a loaded bucket. This is dangerous.
- Never thrust the bucket in when traveling at high speed (when loading soil or crushed rock). This is dangerous.
- When the machine is traveling or the work equipment is raised, the moment that the E.C.S.S. switch is turned ON, the work equipment will move.
- If operations are carried out with the E.C.S.S. switch left at the ON position, the moment that the travel damper is actuated, the work equipment will move.

NOTICE

- If the tires slip, the tire life will be reduced, so do not allow the tires to slip during operation.
- Avoid excessive bucket shaking.

CROSS DRIVE LOADING

Always set the wheel loader facing at a right angle to the stockpile. After digging in and scooping up the load, drive the machine straight back in reverse, then bring the dump truck in between the stock pile and the wheel loader.

This method requires the least time for loading, and is extremely effective in reducing the cycle time.

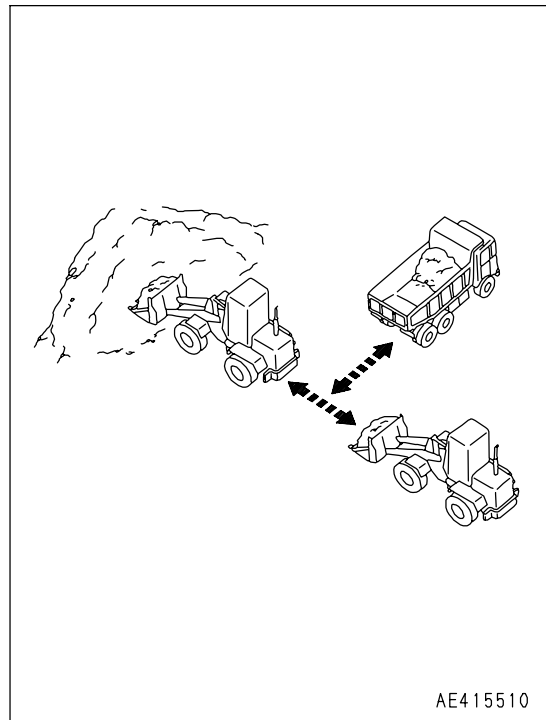

HANDLING THE TIRES

PRECAUTIONS WHEN HANDLING TIRES



If a tire has reached any of the following service limits, there is danger that the tire may burst or cause an accident, so to ensure safety, replace it with a new tire.

- **Service limits for wear**
 When the remaining depth of the grooves on construction equipment tires (at a point approx. 1/4 of the tread width) is 15% of the groove depth on a new tire.
 When the tire shows marked uneven wear, stepped wear or other abnormal wear, or when the cord layer is exposed.
- **Service limits for damage**
 When there is external damage extending to the cord or when the cord is broken
 When the cord is cut or there is dragging
 When the tire is peeling (there is separation)
 When the bead is damaged
 For tubeless tires, when there is air leakage or improper repair
- Do not install a tire protector (mesh chain) to the rear tires.

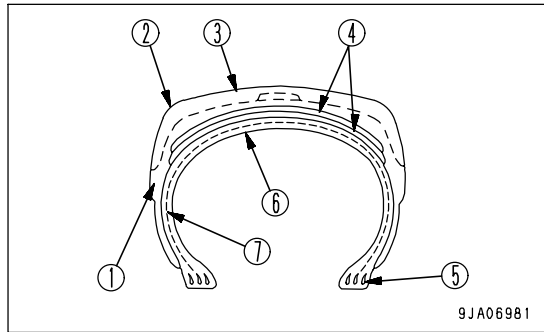

- (1) Side wall
- (2) Shoulder
- (3) Tread
- (4) Breaker or belt (cord layer)
- (5) Bead
- (6) Inner liner
- (7) Carcass

Please contact your Komatsu distributor when replacing the tires. It is dangerous to jack up the machine without taking due care.

TIRE PRESSURE

Measure the tire pressure before starting operations, when the tires are cool.
 If the tire inflation pressure is too low, there will be overload; if it is too high, it will cause tire cuts and shock burst.
 To prevent these problems, adjust the tire inflation pressure according to the table on the next page.
 Deflection ratio = $H - h / H \times 100$

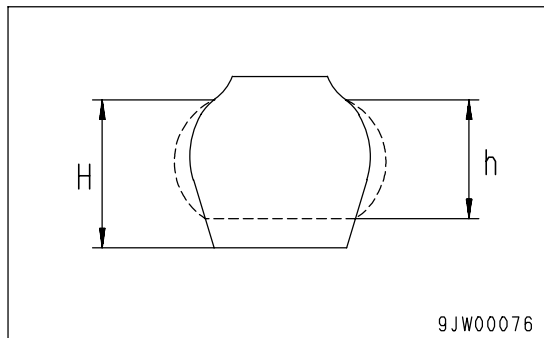

As a guideline that can be checked visibly, the deflection ratio of the front tire (deflection/free height) is as follows.
 When carrying normal load (lift arm horizontal): Approx. 15 to 25 %
 When digging (rear wheels off ground): Approx. 25 to 35 %

LONG-TERM STORAGE

BEFORE STORAGE

When keeping in long-term storage (more than one month), store as follows.

- Clean and wash all parts, then store the machine indoors. If the machine has to be stored outdoors, select level ground and cover the machine with a sheet.
- Completely fill the fuel tank. This prevents moisture from collecting.
- Lubricate and change the oil before storage.
- Coat the exposed portion of the hydraulic cylinder piston rod with grease.
- Disconnect the negative terminals of the battery and cover it or remove it from the machine and store it separately.
- Set the lock lever to the LOCK position to prevent the machine from moving.
- To prevent rust, fill with COOLANT to give a density of at least 30% for the engine coolant.

DURING STORAGE



WARNING

If it is necessary to perform the rust-prevention operation while the machine is indoors, open the doors and windows to improve ventilation and prevent gas poisoning.

- During storage, operate and move the machine for a short distance once a month so that a new film of oil will coat moving parts. At the same time, also charge the battery.
- When operating the work equipment, wipe off all the grease from the hydraulic cylinder rods.
- If the machine is equipped with an air conditioner, operate the air conditioner for 3 to 5 minutes once a month to lubricate all parts of the air conditioner compressor. Always run the engine at low idle when doing this. In addition, check the refrigerant level twice a year.

AFTER STORAGE

NOTICE

If the machine has been stored without carrying out the monthly rust-prevention operation, consult your Komatsu distributor before using it.

When using the machine after long-term storage, do as follows before using it.

- Wipe off the grease from the hydraulic cylinder rods.
- Add oil and grease at all lubrication points.
- When the machine is stored for a long period, moisture in the air will mix with the oil. Check the oil before and after starting the engine. If there is water in the oil, change all the oil.
- Check that there is no rust on the engine pulley and no abnormality in the belt.
If there is excessive rust on the belt contact surface of the pulley, remove it with a wire brush.
- If the belt is loose, adjust the belt tension to ensure that there is no slipping.
(For details of the procedure for adjusting the belt tension, see CHECK ALTERNATOR BELT TENSION, ADJUST (PAGE 4-48).)

CHASSIS

- (): Always contact your Komatsu distributor when dealing with these items.
- In cases of problems or causes which are not listed below, contact your Komatsu distributor for repairs.

Problem	Main causes	Remedy
Transmission		
Engine is running but machine does not move	<ul style="list-style-type: none"> • Parking brake is applied • Directional lever is not shifted properly • Lack of oil in transmission case 	<ul style="list-style-type: none"> • Release parking brake • Shift lever properly • Add oil to specified level. See WHEN REQUIRED
Even when engine is run at full throttle, machine only move slowly and lacks power	<ul style="list-style-type: none"> • Lack of oil in transmission case • Screen is clogged 	<ul style="list-style-type: none"> • Add oil to specified level. See WHEN REQUIRED (• Disassemble, clean)
Oil overheats	<ul style="list-style-type: none"> • Too much oil or too little oil in transmission case • Machine is not traveling in correct speed range • Torque converter is stalled for long periods • Engine is overheating 	<ul style="list-style-type: none"> • Add or drain oil to specified level. See WHEN REQUIRED • Place in correct speed range • Reduce stall time (• Check engine)
Noise generated	<ul style="list-style-type: none"> • Lack of oil in transmission case 	<ul style="list-style-type: none"> • Add oil to specified level. See WHEN REQUIRED
Axle		
Noise generated	<ul style="list-style-type: none"> • Lack of oil • Improper oil used (for machines with limited-slip differential) 	<ul style="list-style-type: none"> • Add oil to specified level. See WHEN REQUIRED • Change to specified oil
Brake		
Brake is not applied when pedal is depressed	<ul style="list-style-type: none"> • Disc has reached wear limit • Lack of oil in hydraulic tank • Air in brake line 	<ul style="list-style-type: none"> (• Replace disc) • Add oil to specified level. See EVERY 100 HOURS • Bleed air
Brake drags or remains applied	<ul style="list-style-type: none"> • Vent hole of brake valve is clogged 	<ul style="list-style-type: none"> • Clean
Brakes squeal	<ul style="list-style-type: none"> • Disc is worn • Large amount of water in axle oil • Deteriorated axle oil due to overuse of brake 	<ul style="list-style-type: none"> (• Replace disc) • Change axle oil • Change axle oil

GREASE

- Grease is used to prevent seizure and noises at the joints.
- This construction equipment is used under heavy-duty conditions. Always use the recommended grease and follow the change intervals and recommended ambient temperatures given in this Operation and Maintenance Manual.
- Grease fittings not included in the maintenance section are grease fittings for overhaul, so they do not need grease.
If any part becomes stiff after being used for long time, add grease.
- Always wipe off all of the old grease that is pushed out when greasing.
Be particularly careful to wipe off the old grease in places where sand or dirt sticking in the grease would cause wear of the rotating parts.

CARRYING OUT KOWA (Komatsu Oil Wear Analysis)

KOWA is a maintenance service that makes it possible to prevent machine failures and downtime. With KOWA, the oil is periodically sampled and analyzed. This enables early detection of wear of the machine drive parts and other problems.

We strongly recommend you to use this service. The oil analysis is carried out at actual cost, so the cost is low, and the results of the analysis are reported together with recommendations which will reduce repair costs and machine downtime.

KOWA ANALYSIS ITEMS

- Measurement of density of metal wear particles
This uses an ICP (Inductively Coupled Plasma) analyzer to measure the density of iron, copper, and other metal wear particles in the oil.

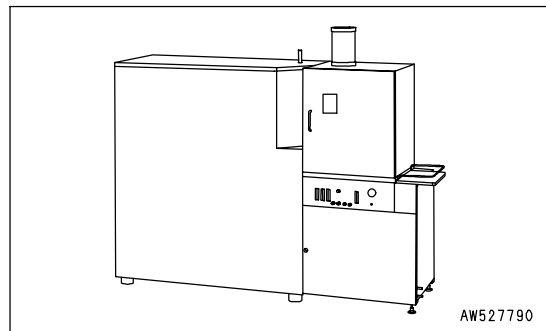

- Measurement of quantity of particles
This uses a PQI (Particle Quantifier Index) measurer to measure the quantity of iron particles of 5µm or more, enabling early detection of failures.

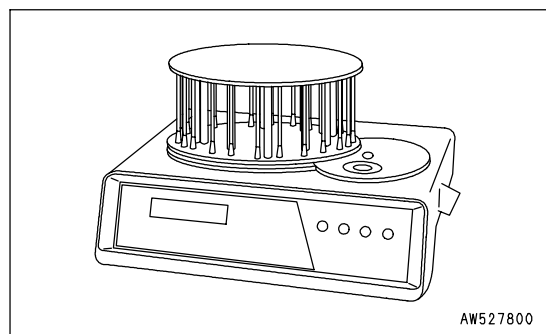

- Others
Measurements are made of items such as the ratio of water in the oil, density of the COOLANT, ratio of fuel in the oil, and dynamic viscosity, enabling a highly precise diagnosis of the machine's health.

REPLACE FUEL PRE-FILTER CARTRIDGE ----- 4- 55

EVERY 1000 HOURS SERVICE

REPLACE FUEL MAIN FILTER CARTRIDGE ----- 4- 57

CHANGE OIL IN TRANSMISSION CASE AND TRANSMISSION OIL FILTER CARTRIDGE, CLEAN STRAINER ----- 4- 59

CLEAN TRANSMISSION CASE BREATHER ----- 4- 60

LUBRICATING ----- 4- 61

CHECK OF ENGINE AIR INTAKE PIPING CLAMPS FOR LOOSENESS ----- 4- 61

EVERY 2000 HOURS SERVICE

CHANGE OIL IN HYDRAULIC TANK, REPLACE HYDRAULIC FILTER ELEMENT ----- 4- 62

REPLACE HYDRAULIC TANK BREATHER ELEMENT ----- 4- 64

CHANGE AXLE OIL(*) ----- 4- 65

REPLACE ELEMENT IN AIR CONDITIONER RECIRCULATION AIR FILTER, FRESH AIR FILTER (IF EQUIPPED) ----- 4- 65

CHECK BRAKE DISC WEAR ----- 4- 66

CHECKING FUNCTION OF ACCUMULATOR ----- 4- 67

CHECK ALTERNATOR ----- 4- 67

CHECK ENGINE VALVE CLEARANCE, ADJUST ----- 4- 67

CHECK VIBRATION DAMPER ----- 4- 67

*: The interval of 2000 hours for changing the axle oil is for standard operations. If the brake is used frequently or the brakes make a sound, change the oil after a shorter interval.

EVERY 4000 HOURS SERVICE

LUBRICATING ----- 4- 68

CHECK WATER PUMP ----- 4- 69

CHECK AIR CONDITIONER COMPRESSOR, ADJUST (IF EQUIPPED) ----- 4- 69

CHECK FOR LOOSE ENGINE HIGH-PRESSURE PIPING CLAMPS, HARDENING OF RUBBER ----- 4- 70

CHECKING FOR MISSING FUEL SPRAY PREVENTION CAP, HARDENING OF RUBBER ----- 4- 70

CHECK STARTING MOTOR ----- 4- 71

EVERY 8000 HOURS SERVICE

REPLACE HIGH-PRESSURE PIPING CLAMP ----- 4- 72

REPLACE FUEL SPRAY PREVENTION CAP ----- 4- 72

CHECK AXLE OIL LEVEL, ADD OIL

! WARNING

- When checking the oil level, apply the parking brake and secure the front and rear frames with the frame lock bar.
- After stopping the engine, the parts and oil are at a high temperature. Wait for the temperature to go down before starting the operation.

Perform this procedure if there is any sign of oil on the axle case.
 Inspect the machine on a horizontal surface.
 (If the road surface is at an angle, the oil level cannot be checked correctly.)

- A: Front B: Rear

1. Stop the engine and remove oil level plug (1).

REMARK

Remove the mud and dirt from around plug (1), then remove the plug.

2. With cloth, wipe off any oil adhering to the oil level gauge attached to plug (1).

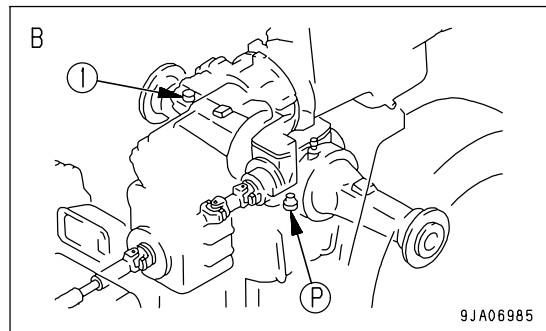
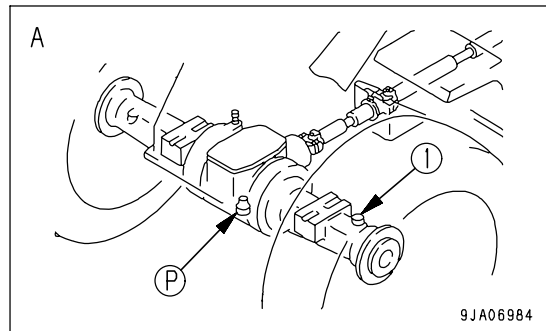

3. Set the oil level gauge (G) as shown in the right diagram.

- (2): Axle
- (3): Spot facing face

4. The oil level should be between the two lines (H) and (L) on the oil level gauge.
 If the oil is below the (L) line, add axle oil through oil filler port (F).

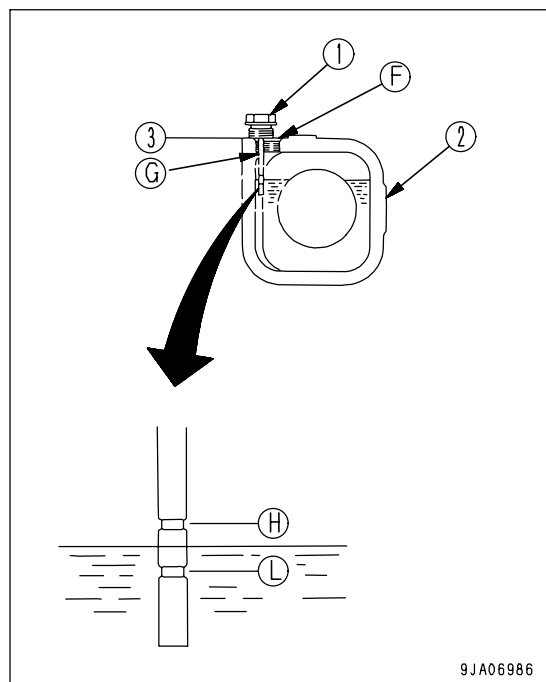

REMARK

For axles with ASD (Limited-Slip Differential), the brand of lubricating oil is different. Use the specified lubricating oil.

- 5. If the oil level is above the (H) line, drain the excess oil through drain plug (P), then check the oil level again.
- 6. If the oil level is correct, install plug (1).
 Tightening torque: 127 to 177 Nm (13 to 18 kgm, 94.0 to 130.2 lbft)

MAINTENANCE AND INSPECTION AND TIME TO EXECUTE THEM

Inspection location	Item to check for	Maintenance interval		
		Check before operating	6 months	Replacement interval
Filter	Clogging, dirt	Carry out check	-	2 years
Condenser	Clogging, dirt	Carry out check	-	-
Belt	Looseness, damage	Carry out check	-	2 years
Refrigerant gas	Amount	-	Carry out check	-
Piping	Looseness, damage, leakage	-	Carry out check	-
Receiver drier	-	-	-	2 years

REPLACE SLOW BLOW FUSE

NOTICE

- Always turn the power OFF when replacing the slow blow fuse (turn the starting switch to the OFF position).
- Always replace the slow blow fuse with a fuse of the same capacity.

If the slow blow fuse should blow, check for the cause and take the necessary action.

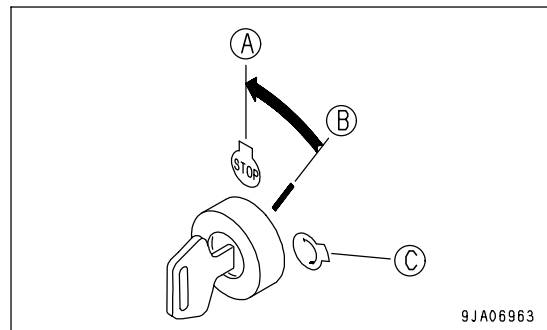

1. Turn the starting switch to the OFF position (A).
2. Remove the slow blow fuse box from the chassis.
3. Open covers (1), (2), and (3) of the slow blow fuse box. Covers (2) and (3) can be removed easily by using protrusion (A) on the body as a fulcrum and levering the catch of the cover with a flat-headed screwdriver to release it.
4. Loosen screws (4) and (5), and remove. When screws (4) and (5) are removed, slow blow fuse (6) will also come off together with electric wiring (7) and (8).
5. Using screws (4) and (5), install a new slow blow fuse together with electric wiring (7) and (8) to the slow blow fuse box, then close covers (1), (2), and (3).
6. Install the slow blow fuse box to the chassis.

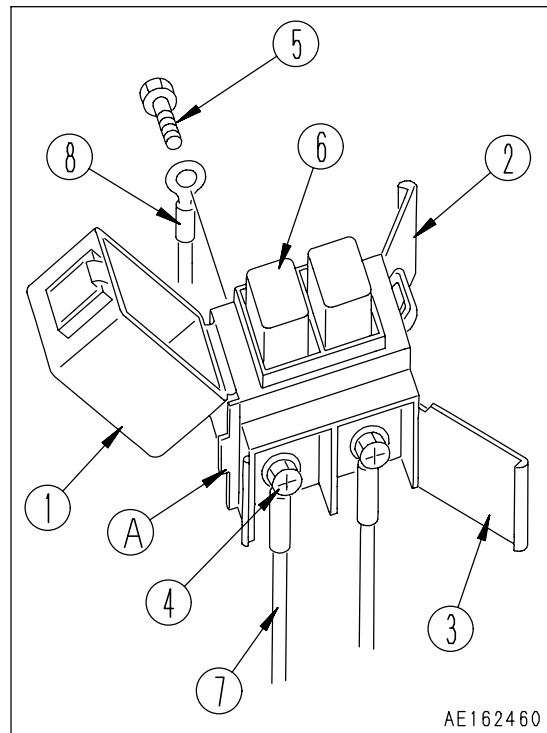

EVERY 250 HOURS SERVICE

Maintenance for every 50 and 100 hours service should be carried out at the same time.

CHECK BATTERY ELECTROLYTE LEVEL

Carry out this procedure before operating the machine.



WARNING

- Do not use the battery if the battery electrolyte level is below the LOWER LEVEL line. This will accelerate deterioration of the inside of the battery and reduce the service life of the battery. In addition, it may cause an explosion.
- The battery generates flammable gas and there is danger of explosion, do not bring fire or sparks near the battery.
- Battery electrolyte is dangerous. If it gets in your eyes or on your skin, wash it off with a large amount of water and consult a doctor.
- When adding distilled water to the battery, do not allow the battery electrolyte to go above the UPPER LEVEL line. If the electrolyte level is too high, it may leak and cause damage to the paint surface or corrode other parts.

NOTICE

If there is a fear that the battery water may freeze after refilling with purified water (e.g. commercially available replenishment water for a battery), do the replenishment before the day's work on the next day.

Inspect the battery electrolyte level at least once a month and follow the basic safety procedures given below.

WHEN CHECKING ELECTROLYTE LEVEL FROM SIDE OF BATTERY

If it is possible to check the electrolyte level from the side of the battery, check as follows.

1. Open the cover of the battery box.

There are two battery boxes: One on each side at the rear of the machine.

2. Use a wet cloth to clean the area around the electrolyte level lines and check that the electrolyte level is between the UPPER LEVEL (U.L.) and LOWER LEVEL (L.L.) lines.

If the battery is wiped with a dry cloth, static electricity may cause a fire or explosion.

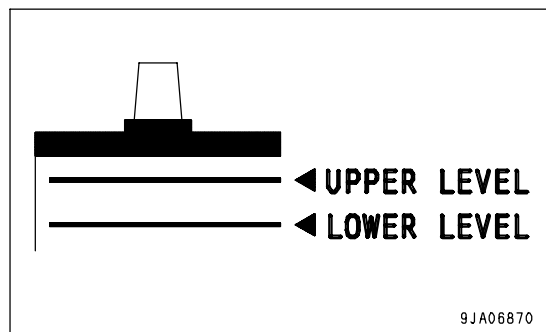

3. If the electrolyte level is below the midway point between the UPPER LEVEL (U.L.) and LOWER LEVEL (L.L.) lines, remove cap (1) and add distilled water to the U.L. line.

4. If distilled water has been added to any cell of cap (1), add distilled water also to the other cells.

5. Clean the vents of the battery caps, then close the caps securely.

Keep the top of the battery clean and wipe it with a wet cloth.

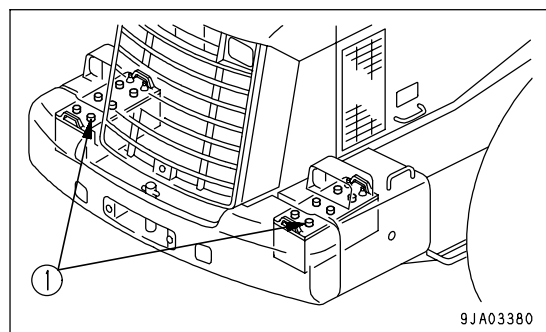

NOTICE

When filling the filter cartridge with fuel, carry out the filling operation with cap (A) fitted.

Cap (A) acts to prevent the entry of dirt or dust into the filter cartridge.

9. Fill the filter cartridge with clean fuel through the 8 small holes (B) in the new filter cartridge.
10. Coat the packing surface of the filter cartridge with oil.

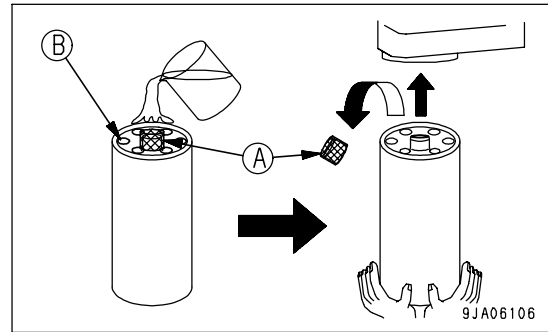

11. Remove filter cartridge cap (A) and install to the filter holder.
12. When installing, tighten until the packing surface contacts the seal surface of the filter holder, then tighten it 3/4 of a turn.
If the filter cartridge is tightened too far, the packing will be damaged and this will lead to leakage of fuel. If the filter cartridge is too loose, fuel will also leak from the packing, so always tighten the correct amount.
 - When tightening with a filter wrench, be extremely careful not to dent or damage the filter.
13. When replacing the fuel main filter cartridge (EVERY 1000 HOURS), see "REPLACE FUEL MAIN FILTER CARTRIDGE (PAGE 4-57)" for details and bleed the air after replacing the cartridge.
Note: Do not put any fuel in the main filter cartridge.
14. Start the engine, check that there is no leakage of fuel from the filter seal surface or water separator mounting surface, then run for approx. 10 minutes at low idling.

CHECK BRAKE DISC WEAR

**WARNING**

- When checking the brake disc wear, apply the parking brake and secure the front and rear frames with the frame lock bar.
- Make sure that the brake oil temperature is less than 60°C (140°F) before checking the brake wear.
- If the disc is near the wear limit, carry out inspection at shorter intervals, regardless of the specified inspection interval.

When checking the brake disc for wear, there are 4 places (front axle and rear axle, left and right), so use the same procedure to check all 4 places.

1. Remove cap nut (1).

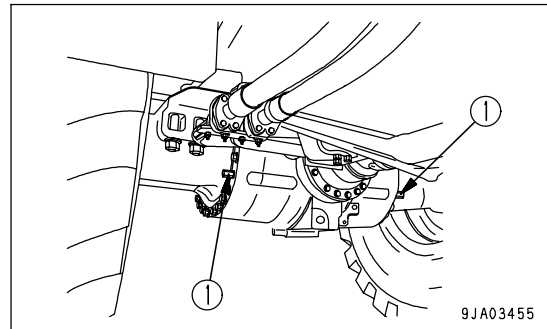

2. Depress the brake pedal and push in rod (2) fully.
3. Amount of wear (A) is the amount that end face (C) of the rod protrudes from end face (D) of the guide. Measure the amount of protrusion.

Permitted wear limit (B) of the disc is the point where groove (E) of the rod is in line with end face (D) of the guide.

When this point is reached, please ask your Komatsu distributor to carry out inspection and replacement of parts.

- If the disc is near the wear limit, carry out inspection at shorter intervals, regardless of the specified inspection interval.

4. Install cap nut (1).

Tightening torque: 29.4 to 39.2 Nm (3.0 to 4.0 kgm, 21.7 to 28.9 lbft)

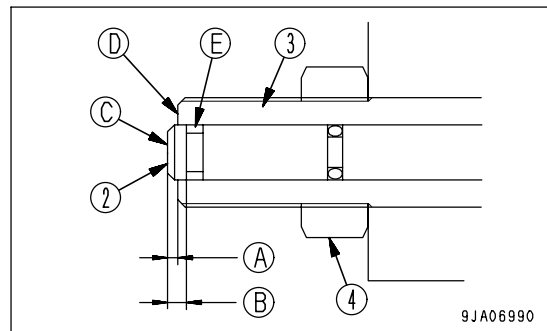
**REMARK**

- On new machines, the position of the guide is adjusted so that the end face of rod (2) comes to the end face of guide (3). For this reason, do not loosen locknut (4) except when replacing the disc.
- Carry out the operation with two workers: one worker depresses the brake pedal and the other worker pushes in rod (2).

SELECTING BUCKET AND TIRES

Select the most suitable bucket and tires for the type of work and the ground conditions on the jobsite.

Type of work	Bucket	Ground conditions	Tire
Loading products Loading and carrying products	Stockpile bucket (with bolt-on cutting edge) (4.2 m ³ (5.5 cu.yd))	General ground conditions	26.5-25-16PR (L3 Rock)
	Stockpile bucket (with teeth, segment edge) (4.2 m ³ (5.5 cu.yd))	Leveled ground	26.5-25-16PR (L2 Traction)
	Stockpile bucket (with teeth) (3.9 m ³ (5.1 cu.yd))		
	Loose material bucket (with bolt-on cutting edge) (4.6 m ³ (6.0 cu.yd))	Soft ground	26.5-25-16PR (L2 Traction)
	Light material bucket (with bolt-on cutting edge) (5.2 m ³ (6.8 cu.yd))		
Loading crushed rock	Excavating bucket (with bolt-on cutting edge) (3.8 m ³ (5.0 cu.yd))	General ground conditions	26.5-25-20PR (L3 Rock)
	Excavating bucket (with teeth, segment edge) (3.8 m ³ (5.0 cu.yd))	Leveled ground	26.5-25-16PR (L3 Rock)
			26.5-25-16PR (L3 Rock)
	Excavating bucket (with teeth) (3.6 m ³ (4.7 cu.yd))	Ground with many light rocks	26.5-25-20PR (L3 Rock)
	Spade nose rock bucket (3.6 m ³ (4.7 cu.yd))	Soft ground with many light rocks	26.5-25-20PR (L3 Rock)
		Soft ground with many light rocks	23.5-25-20PR (L3 Rock)

BOC indicates a bolt-on type cutting edge.

The displayed travel speed changes according to the tire size, so when installing optional tires, please contact your Komatsu distributor.

SEAT ADJUSTMENT



WARNING

- When adjusting the operator's seat, stop the machine in a safe place before starting the operation.
- Adjust the seat before starting operations for the day or when changing operators.
- When adjusting the seat, put your back against the backrest and adjust to a position where the brake pedal can be fully depressed.

An air compressor built into the seat is used for adjustment (C) and (D), so turn the engine starting switch to the ON position before starting the adjustment.

NOTICE

There is danger of damage to the air compressor, so do not keep lever (3) operated continuously for more than 1 minute.

(A) Fore-and-aft adjustment

Move lever (1) up and move the seat to the desired position and release the lever.

Fore-and-aft adjustment: 210 mm (10 mm x 21 stages)
(8.3 in (0.4 in) x 21 stages)

(B) Adjusting seat angle

Move lever (2) up, move the seat cushion at the front up or down to set to the desired position, then release the lever.

Amount of adjustment
Forward tilt: 3 degrees
Rear tilt: 11 degrees

(C) Adjusting seat height

The seat height adjustment uses an air system, and it can be adjusted steplessly.

When adjusting the height, pull lever (3) up fully or push it down fully (when pulling it up, pull it until a click is felt). When the seat is set at the desired height, release the lever. If the lever is kept pulled up, the position where the seat does not rise any further is the maximum height. When the seat reaches the maximum height, the suspension automatically goes down slightly to secure the amount of movement of the lever.

If the operator raises his body from the seat or changes the amount of weight applied to the seat during adjustment, the air in the suspension may be discharged.

Amount of adjustment: 80 mm (3.2 in)

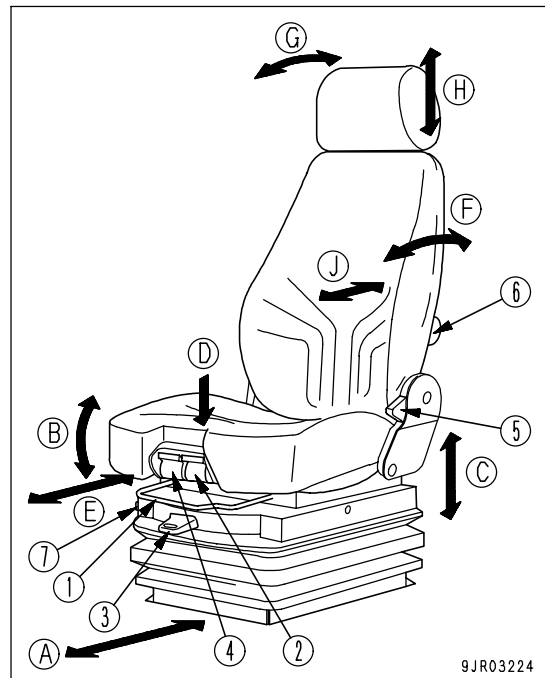

9JR03224

REMARK

If the lever is operated in the RAISE direction from the maximum height, the compressor may continue to operate for approx. 8 seconds, but this does not indicate any abnormality with the seat.

If this happens, the compressor will stop automatically after approx. 8 seconds. The compressor will also stop if the height control lever is operated in the LOWER direction.

FNR SWITCH

This switch (4) is used to change the direction of travel of the machine.

Position (F): FORWARD

Position (N): Neutral

Position (R): REVERSE

Before operating this switch, check that the condition is as follows.

- Directional lever is at N
- Directional selector switch actuation switch is at ON

If the condition is not as above, the switch will not work.

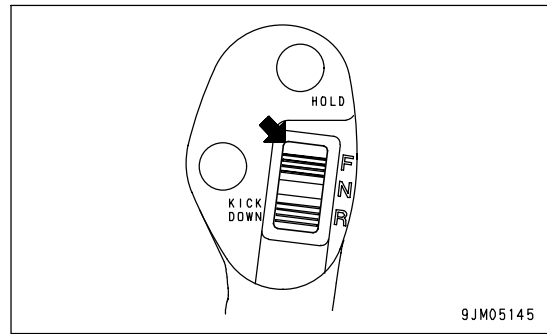

DIRECTIONAL SELECTOR SWITCH ACTUATION SWITCH

When this switch (5) is pressed, the FNR switch on the head of the multi-function lever is activated.

Position (a): ON

The pilot lamp inside the switch and the directional selection pilot lamp on the machine monitor light up, and the FNR switch is activated.

Position (b): OFF

The FNR switch is not activated.

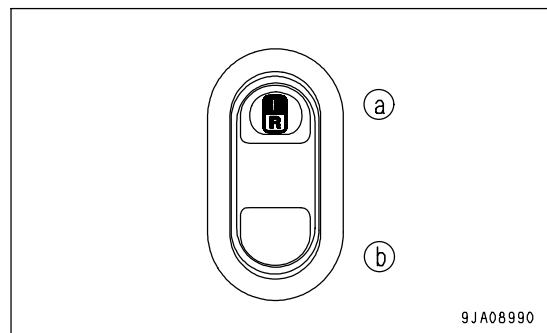

DIRECTIONAL SELECTOR PILOT LAMP

This monitor (6) lights up when the directional selector switch actuation switch on the right switch panel is turned ON. It indicates that it is possible to operate the travel direction of the machine with the FNR switch on the head of the multi-function lever.

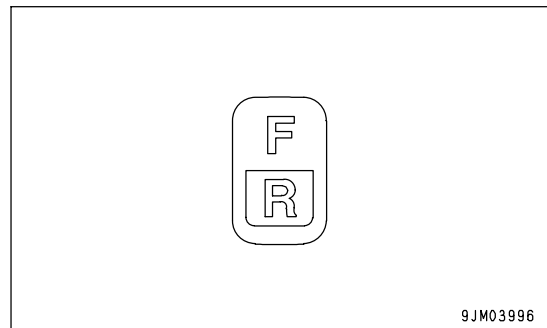

USING LOAD METER

SETTING ADDITION MODE

1. Press the load meter mode selector switch (+/-) to display "TOTAL LOADED" on the load meter.

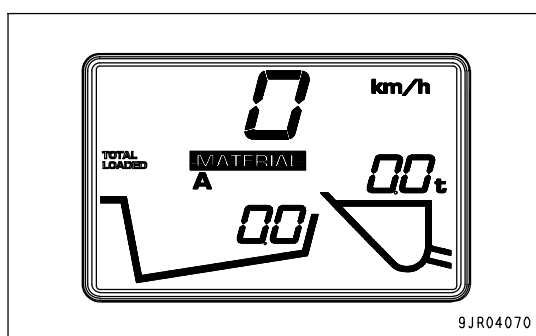
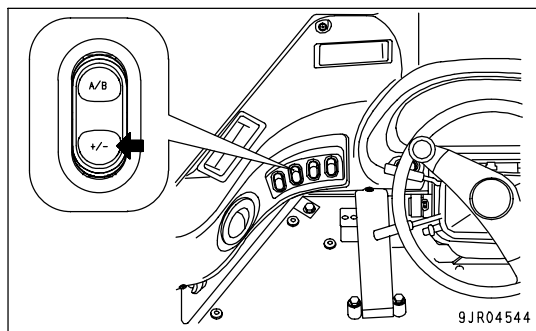

2. Press the load meter mode selector switch (A/B) to select the category of load material.
This completes the setting of the addition mode. Calculation starts.

REMARK

When the load meter is set to the addition mode, even when the starting switch is turned OFF and operations are stopped, when operations begin again with the same type of mode, there is no need to reset. The new load is added to the load existing before operations were stopped.

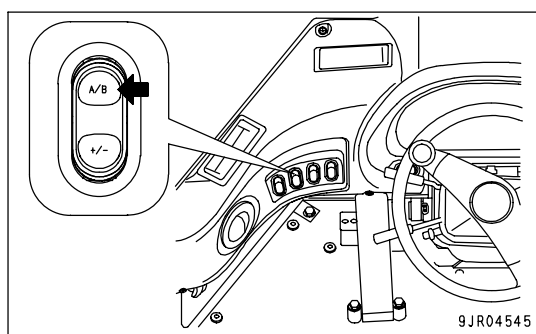

CALIBRATING WITH EMPTY BUCKET

1. Before carrying out calibration, set the machine in the following condition.

- 1) Empty the bucket.
- 2) Carry out the warming-up operation.

Carry out warming up to set the hydraulic oil temperature to the normal working range, then carry out normal operations (including raising and lowering the lift arm) for at least 10 minutes (preferably more than 30 minutes).

2. Set so that the character display shows the normal service meter and clock display.

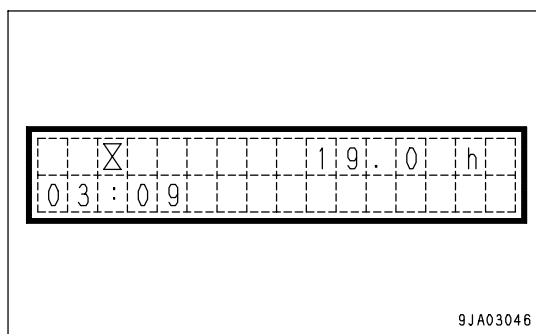

3. Press the (◇) portion of the machine monitor mode selector switch 1.

"LOAD METER" is displayed on the top line of the character display.

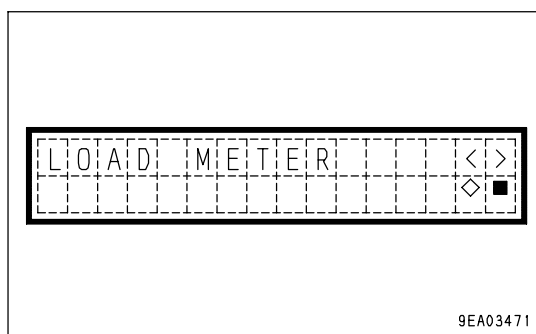
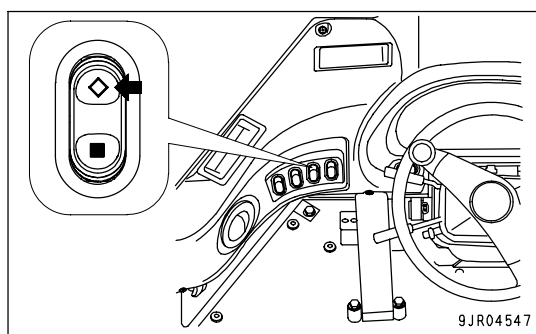

METHOD OF USING ADDITION MODE

1. Set the load meter to the addition mode. For details, see "SETTING ADDITION MODE (PAGE 6-32)".

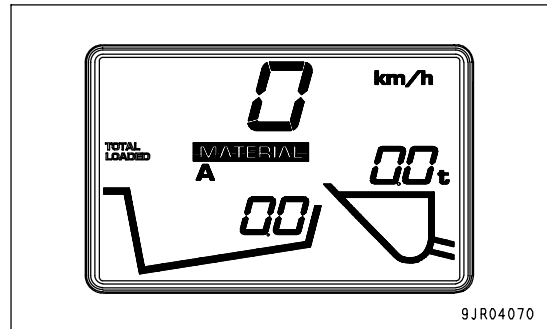

The following explanation uses "A" selected as the "MATERIAL" as an example.

2. Fill the bucket with the first load, tilt the bucket fully, raise the lift arm above the horizontal position, then load the dump truck. Let us take the load as 5.1t.
The display shows the bucket load as 5.1t, and the total load display shows 5.1.

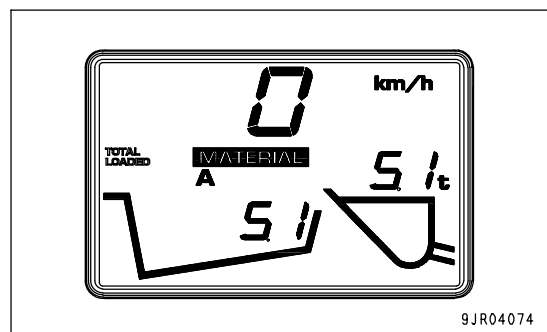
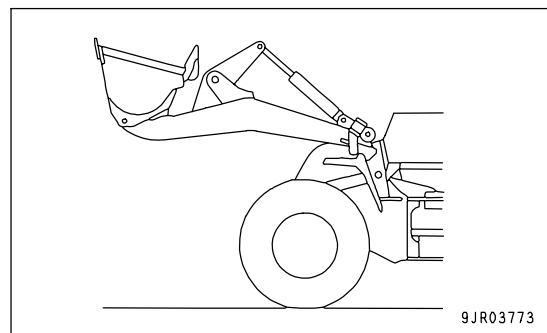

6. When the system is set to C mode, the data are printed out when the setting is made and the print mode returns to A or B.

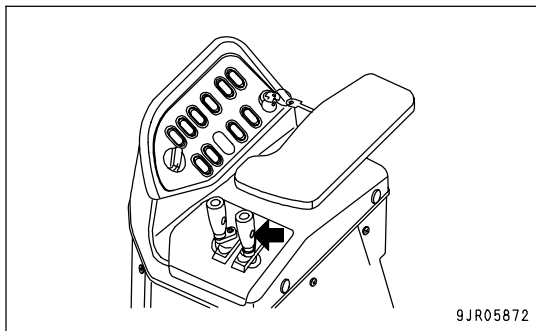

7. To print out in A or B mode, press the load meter sub-total switch.
The data are printed out.

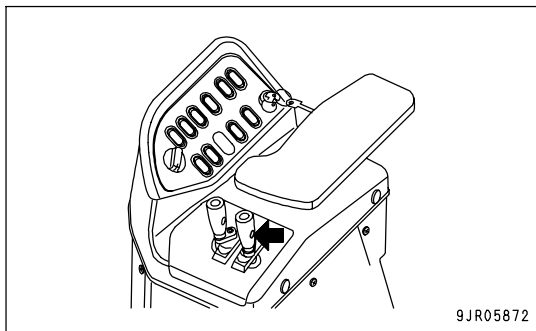

REMARK

If you make a mistake in the setting, press the (■) portion of the machine monitor mode selector switch 1.
The display will return to the previous display.

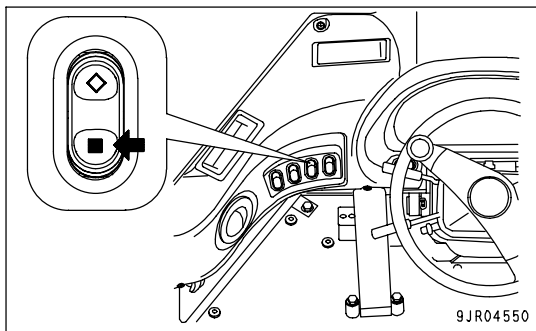

IMPORTANT INFORMATION

Before you use your car audio system for the first time, please take the time to read the instruction manual carefully and make yourself familiar with the audio equipment.

Keep this manual handy in your car for future reference.

TRAFFIC SAFETY

- Traffic safety is always the top priority.
Do not operate your car audio system unless the traffic conditions permit.
- Familiarize yourself with the equipment before you start driving.
- Always make sure that you are still able to hear any warning signals coming from outside the vehicle, such as police or engine sirens, at all times.
- Consequently, you should always select a moderate volume for playing your car audio system while you are driving.

REMOTE CONTROL(OPTION)

An infrared remote control unit is available optionally.

Using the RC 10 P you can conveniently operate the most important system functions by remote control.

CD CHANGER(OPTION)

The CDC A 08 T CD changer can be connected to the system.

The CD changer is available as an option.

AMPLIFIER(OPTION)

An additional amplifier can be connected to the radio to increase the volume and sound volume in the vehicle.

The amplifier is available as an accessory.

RESETTING THE TONE AND THE BALANCE AND FADER

You can reset the tone and balance/fader settings to zero.

To reset these settings press GEO (11) for longer than two seconds.
"AUD ZERO" will appear briefly in the display (15).

RADIO OPERATION

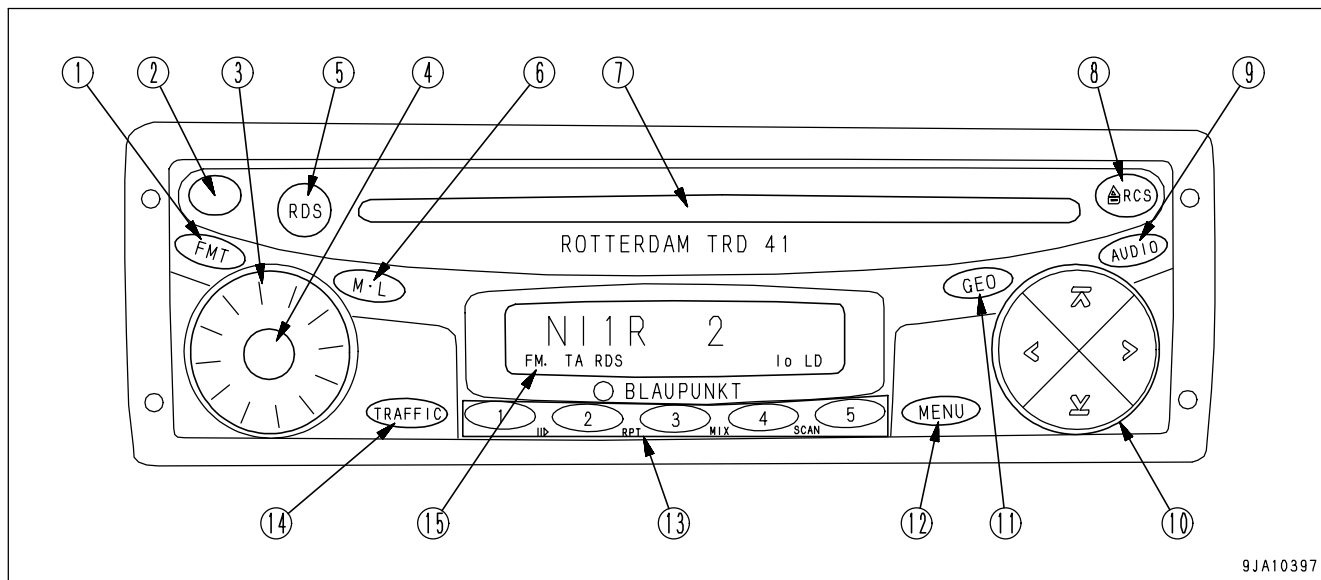

This car audio system has been equipped with an RDS radio receiver.

Along with their regular station programming, many FM radio stations now transmit the RDS signal, which contains such other information as the station name and the program type (PTY).

As soon as the car audio system receiver detects the station name, it will appear in the display (15).

SWITCHING TO THE RADIO MODE

If you are currently using the CD player or the CD changer, press SRC (8) repeatedly until "RADIO" appears in the display (15).

SPECIAL RDS FUNCTIONS(AF,REG)

The special RDS functions for AF (Alternate Frequency) and REG (Regional) enhance the performance of your car audio system.

AF: If this RDS function is activated, the car audio system continuously searches in the background for the frequency with the best reception for the station you have tuned into.

REG: A number of radio stations broadcast different regional programming at different times of the day. Use REG to prevent your car audio system from tuning into alternate frequencies which might have different programming.

REMARK

It is necessary to activate/deactivate REG in the menu.

SWITCHING THE DISPLAY MODE

To switch the display between "PLAY" and "TIME".

1. Press MENU (12).
"MENU" will appear in the display (15).
2. Press (17) repeatedly until "CD DISP" appears in the display (15).
3. Use < (18) and > (19) to select the desired setting.
The current setting will appear in the display (15).
"TIME" will display the track number and the playing time or
"PLAY" for the track number and "PLAY".
4. Press MENU (12) twice.

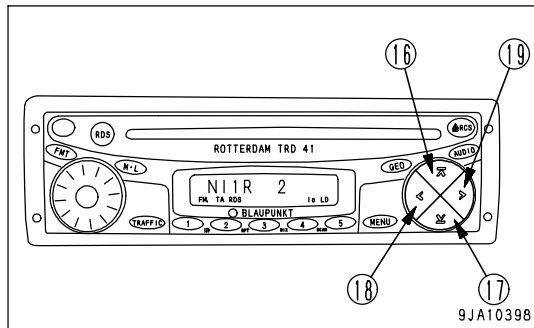

TRAFFIC RADIO INFORMATION DURING CD PLAYBACK

If you would like to receive traffic radio information while listening to your CD player, press TRAFFIC (14).
"TA" will light up in the display (15) to indicate that priority for traffic radio announcements has been activated.

CD EJECT

To remove a CD from the CD player, press SRC (8) until the CD ejects.

Do not try to assist or prevent the CD eject process.

If the CD is not removed from the slot within 20 seconds after it is ejected, it will be automatically pulled back into the CD player.

CLICK HERE TO **DOWNLOAD** THE COMPLETE MANUAL

- Thank you very much for reading the preview of the manual.
- You can download the complete manual from: www.heydownloads.com by clicking the link below



- Please note: If there is no response to CLICKING the link, please download this PDF first and then click on it.

CLICK HERE TO **DOWNLOAD** THE COMPLETE MANUAL