

Operation & Maintenance Manual

WHEEL LOADER

WA470-5

SERIAL NUMBERS 80613 and up

⚠ WARNING

Unsafe use of this machine may cause serious injury or death. Operators and maintenance personnel must read this manual before operating or maintaining this machine. This manual should be kept near the machine for reference and periodically reviewed by all personnel who will come into contact with it.

NOTICE

Komatsu has Operation & Maintenance Manuals written in some other languages. If a foreign language manual is necessary, contact your local distributor for availability.

KOMATSU

CLICK HERE TO **DOWNLOAD** THE COMPLETE MANUAL

- Thank you very much for reading the preview of the manual.
- You can download the complete manual from: www.heydownloads.com by clicking the link below



- Please note: If there is no response to CLICKING the link, please download this PDF first and then click on it.

CLICK HERE TO **DOWNLOAD** THE COMPLETE MANUAL

WHEN REQUIRED -----	4- 18
CHECK BEFORE STARTING -----	4- 41
EVERY 50 HOURS SERVICE -----	4- 42
EVERY 100 HOURS SERVICE -----	4- 43
EVERY 250 HOURS SERVICE -----	4- 45
EVERY 500 HOURS SERVICE -----	4- 52
EVERY 1000 HOURS SERVICE -----	4- 55
EVERY 2000 HOURS SERVICE -----	4- 60
EVERY 4000 HOURS SERVICE -----	4- 67
EVERY 8000 HOURS SERVICE -----	4- 70
SPECIFICATIONS -----	5- 1
SPECIFICATIONS -----	5- 2
ATTACHMENTS, OPTIONS -----	6- 1
HANDLING LOAD METER -----	6- 2
GENERAL LOCATIONS -----	6- 2
LOAD METER FUNCTIONS -----	6- 4
HANDLING LOAD METER DISPLAY -----	6- 7
METHOD OF SETTING TIME ON CLOCK -----	6- 22
PRINTER OUTPUT -----	6- 24
HANDLING TORQUE CONVERTER LOCK-UP -----	6- 27
GENERAL LOCATIONS -----	6- 27
METHOD OF OPERATION -----	6- 28
WARNING/LIMIT FUNCTIONS FOR TRAVEL SPEED -----	6- 29
HANDLING AUTO-GREASING SYSTEM -----	6- 30
METHOD OF OPERATING AUTO-GREASING SYSTEM -----	6- 30
PRECAUTIONS WHEN HANDLING AUTO-GREASING SYSTEM -----	6- 36
TROUBLESHOOTING -----	6- 36
HANDLING JOYSTICK STEERING SYSTEM -----	6- 37
EXPLANATION OF COMPONENTS -----	6- 37
STRUCTURE AND FUNCTION OF JOYSTICK STEERING -----	6- 39
GETTING IN OR OUT OF OPERATOR'S CAB -----	6- 41
ADJUSTMENT OF JOYSTICK CONSOLE -----	6- 41
OPERATION METHOD OF JOYSTICK STEERING SYSTEM -----	6- 42
HANDLING EPC WORK EQUIPMENT LEVER -----	6- 45
OPERATIONAL FEATURES -----	6- 45
SWITCHES -----	6- 45
SEMI AUTO DIGGING OPERATIONS -----	6- 46
METHOD OF REMOTE POSITIONER -----	6- 48
HANDLING MULTI-FUNCTION LEVER -----	6- 50
EXPLANATION OF COMPONENTS -----	6- 50
USING FNR SWITCH TO CHANGE BETWEEN FORWARD AND REVERSE -----	6- 54
INDEX -----	7- 1

(16) "Do not go under work equipment" sign (09807-C0883)



Sign indicates a crush hazard from falling off of working device.

Keep away when the working device is raised.

(17) "Do not modify ROPS" sign (09620-30201)

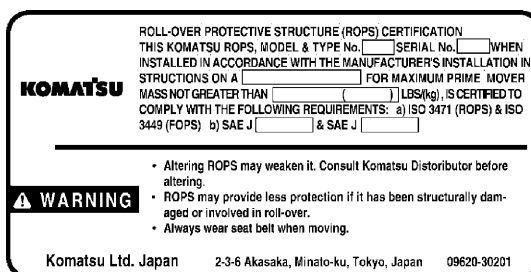

(18) Jump start prohibited (09842-A0481)



Start the engine only after sitting down in the operator's seat.

Do not attempt to start the engine by short-circuiting the engine starting circuit. Such an act may cause a serious bodily injury or fire.

PRECAUTIONS FOR OPERATION

STARTING ENGINE

If there is a warning tag hanging from the work equipment control lever, do not start the engine or touch the levers.

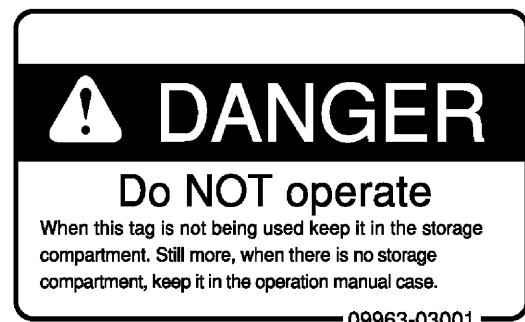
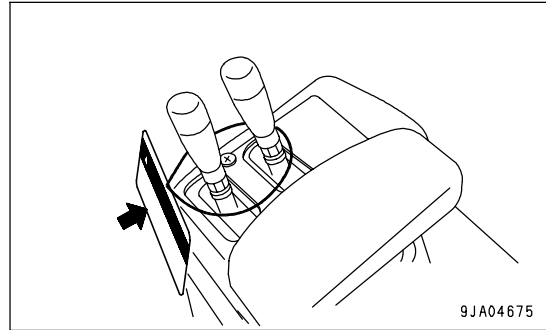

CHECKS BEFORE STARTING ENGINE

Carry out the following checks before starting the engine at the beginning of the day's work.

- Remove all dirt from the surface of the window glass to ensure a good view.
- Remove all dirt from the surface of the lens of the front lamps, working lamps, and rear combination lamp, and check that they light up correctly.
- Check the coolant level, fuel level, and oil level in engine oil pan, check for clogging of the air cleaner, and check for damage to the electric wiring.
- Check that there is no mud or dust accumulated around the movable parts of the accelerator pedal or brake pedal, and check that the pedals work properly.
- Adjust the operator's seat to a position where it is easy to carry out operations, and check that there is no damage or wear to the seat belt or mounting clamps.
- Check the operation of the instruments and gauges, check the angle of the mirror, and check that the control levers are all at the Neutral position.
- Before starting the engine, make sure that the work equipment lock lever is in the LOCK position.
- Adjust the mirrors so that the rear of the machine can be seen clearly from the operator's seat. See "ADJUST REAR VIEW MIRROR (PAGE 3-103)".
- Check that there are no persons or obstacles above, below, or in the area around the machine.

PRECAUTIONS WHEN STARTING

- Start and operate the machine only while seated.
- Do not attempt to start the engine by short-circuiting the engine starting circuit. Such an act may cause a serious bodily injury or fire.
- When starting the engine, sound the horn as a warning.
- Do not allow anyone apart from the operator to ride on the machine.
- When starting the engine, always check that the work equipment control levers are at the HOLD position.

STARTING WITH BOOSTER CABLES

If any mistake is made in the method of connecting the booster cables, it may cause the battery to explode, so always do as follows.

- When starting with a booster cable, carry out the starting operation with two workers (one worker sitting in the operator’s seat and the other working with the battery).
- When starting from another machine, do not allow the two machines to touch.
- When connecting the booster cables, turn the starting switch OFF position for both the normal machine and problem machine. There is a hazard that the machine will move when the power is connected.
- Be sure to connect the positive (+) cable first when installing the booster cables. Disconnect the negative (-) cable (ground side) first when removing them.
- When removing the booster cables, be careful not to let the booster cable clips touch each other or to let the clips touch the machine.
- Always wear safety glasses and rubber gloves when starting the engine with booster cables.
- When connecting a normal machine to a problem machine with booster cables, always use a normal machine with the same battery voltage as the problem machine.
- For details of the starting procedure when using booster cables, see "STARTING ENGINE WITH BOOSTER CABLE (PAGE 3-160)" in the OPERATION section.

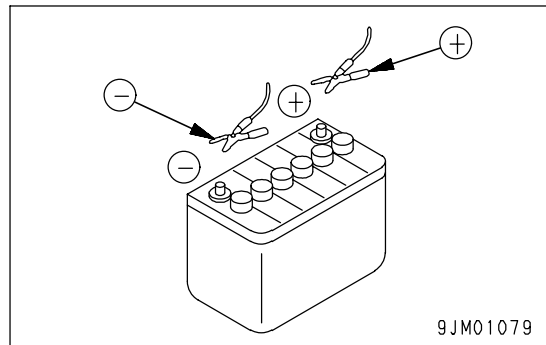
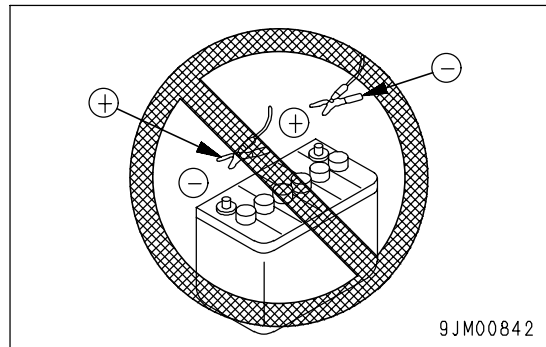

E02: If this code is displayed, stop the machine and run the engine under no load at a mid-range speed.
 If an action code is still displayed after taking the necessary action, check the failure code and contact your Komatsu distributor for repairs.

REMARK

The top line of the character display displays "E02" and the bottom line displays the condition of the machine related to overheating.

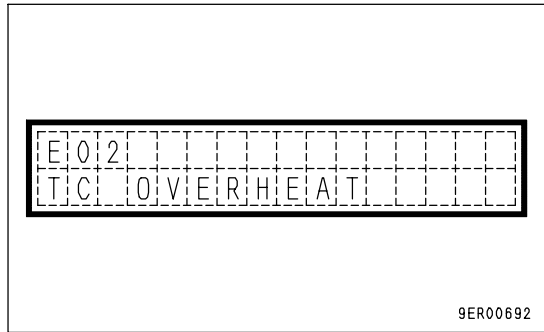

9ER00692

E01: When a failure occurs in the mechanical system, such as a drop in the level of the engine coolant, the maintenance location is displayed. If the maintenance caution lamp lights up at the same time, inspect and perform maintenance of the item indicated after completion of the day's work or when changing shifts. If "MAINTENANCE" is displayed together with E01, check the failure code and ask for repairs to be carried out.

REMARK

"E01" is displayed on the top line of the character display and "MAINTENANCE" or the part of the machine requiring inspection, filling of fluid, or replacement is displayed on the bottom line.

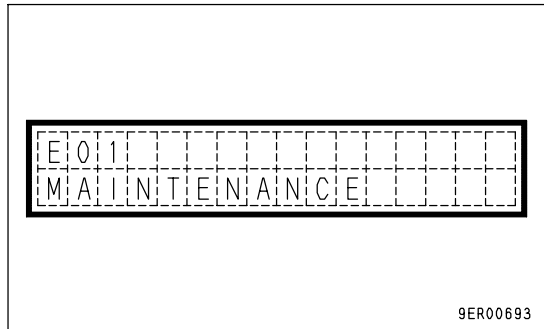

9ER00693

E00: If an overrun related item is displayed, continue operations at reduced engine speed and travel speed.
 If an item related to the work equipment control lever is displayed, return the lever to the HOLD position. (Machines equipped with EPC)

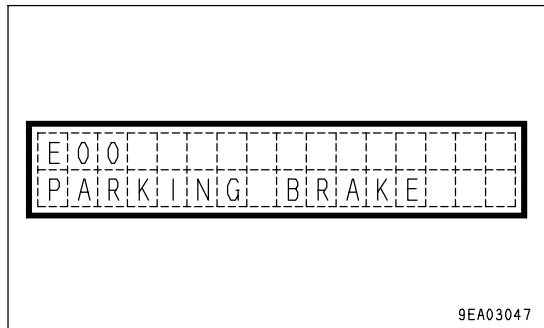

9EA03047

INSPECTION AND MAINTENANCE ITEMS

CAUTION

If these lamps light up, stop operations quickly and carry out the following action.

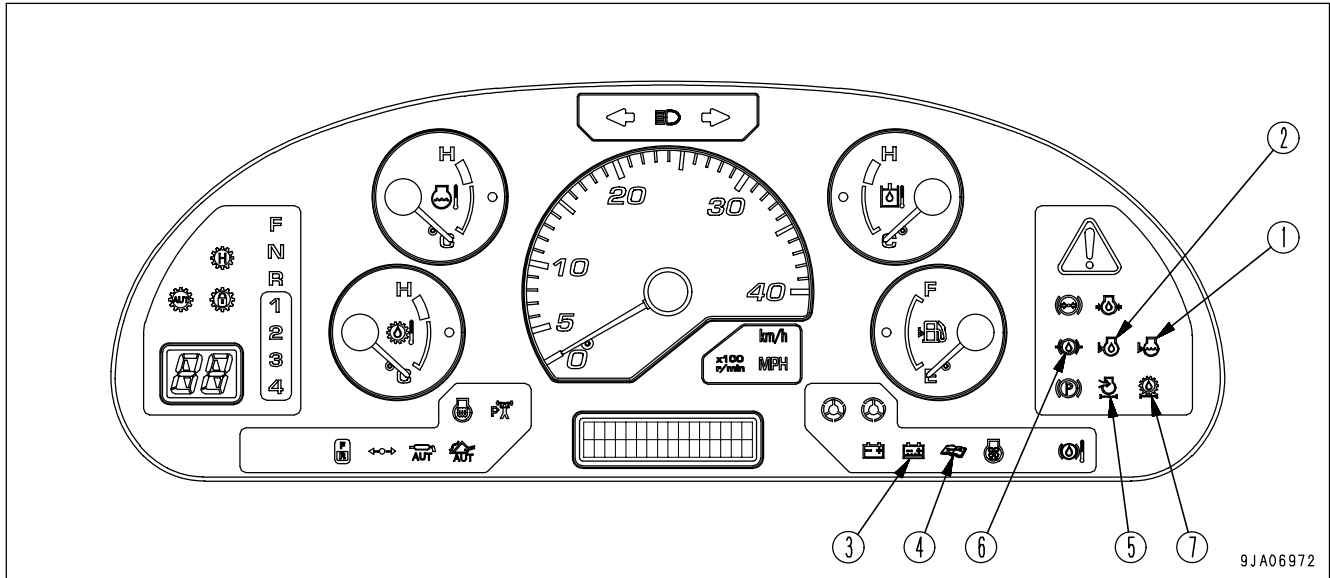

- (1) Radiator coolant level caution lamp
- (2) Engine oil level caution lamp
- (3) Battery electrolyte level caution lamp (if equipped)
- (4) Maintenance caution lamp
- (5) Air cleaner clogging caution lamp
- (6) Brake oil level caution lamp
- (7) Transmission oil filter clogging caution lamp

RADIATOR COOLANT LEVEL CAUTION LAMP

This lamp (1) lights up to warn the operator that the coolant level in the radiator has gone down.

During checks before starting (when the starting switch is turned to the ON position but the engine is not started), this monitor lights up if the coolant level in the radiator is low.

At the same time, the top line of the character display displays "E01" and the bottom line displays "COOLANT LOW", so check the water level in the radiator and add water.

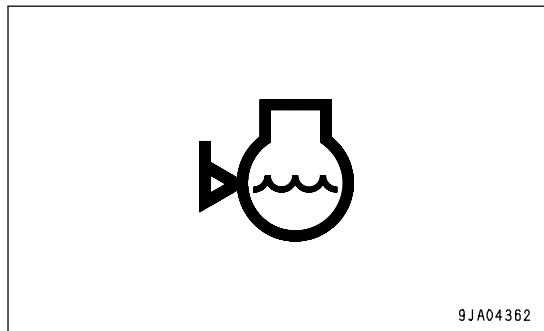

During operation (engine running)

If the coolant level in the radiator becomes too low, the radiator coolant level caution lamp will light up.

At the same time, the top line of the character display displays "E01" and the bottom line displays "COOLANT LOW", so stop the engine, check the water level in the radiator, and add water.

HYDRAULIC OIL TEMPERATURE GAUGE

This meter (3) indicates the hydraulic oil temperature.

It should be in white range (A) during operations.

If it enters red range (B) during operations, caution lamp (C) inside the hydraulic oil temperature gauge will light up. At the same time, the central warning lamp lights up and the alarm buzzer sounds intermittently. In addition, "E02" is displayed on the top line of the character display and "HYD OVERHEAT" is displayed on the bottom line.

Run the engine under no load at a mid-range speed and wait until the indicator goes down to white range (A).

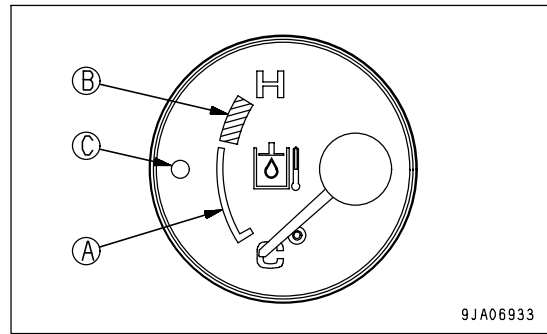

9JA06933

FUEL GAUGE

This meter (4) indicates the amount of fuel remaining in the fuel tank.

F: Full tank

E: Fuel level is low

When the remaining amount of fuel goes below 36 liters (9.51 US gal), caution lamp (A) inside the fuel gauge lights up.

If it lights up, check and add fuel.

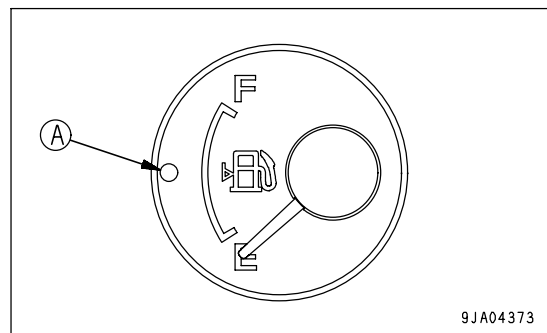

9JA04373

SPEEDOMETER

This meter (5) indicates the travel speed of the machine.

The display unit is indicated on meter display pilot lamp (6).

It is also possible to display the engine speed by switching meter (5).

If you wish to switch between the speedometer and tachometer, please contact your Komatsu distributor to have it switched.

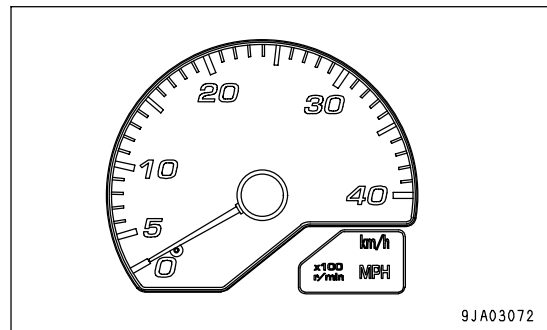

9JA03072

METER DISPLAY PILOT LAMP

This lamp (6) displays the unit for the travel speed or engine tachometer.

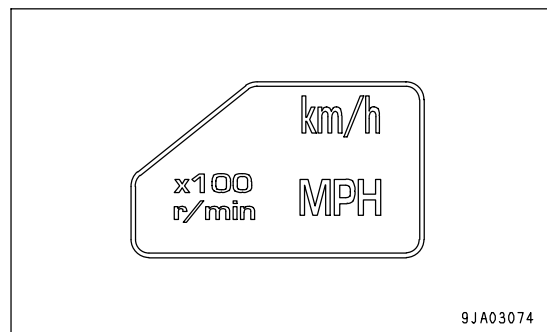

9JA03074

LAMP SWITCH

This switch (6) is used to light up the front lamps, side clearance lamps, tail lamps, and instrument panel.

Position (a): OFF

Position (b): Side clearance lamps, tail lamps, and instrument panel light up

Position (c): Head lamps light up in addition to lamps at (b) position

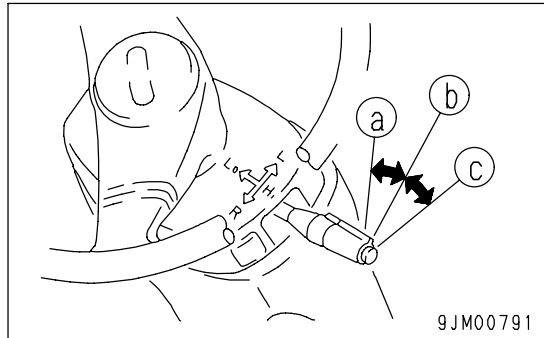

REMARK

The lamp switch can be operated regardless of the position of the lever.

TURN SIGNAL LEVER

This lever (6) is used to operate the turn signal lamp.

(a) position: LEFT TURN (Push lever FORWARD.)

(b) position: RIGHT TURN (Pull lever BACK.)

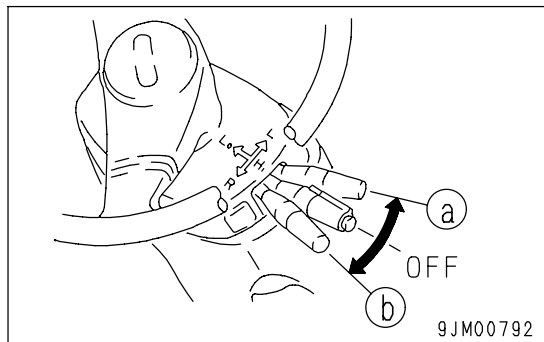

REMARK

- When the lever is operated, the turn signal pilot lamp also flashes.
- When the steering wheel is turned back, the lever automatically returns to its original position. If it does not return, return it manually.

DIMMER SWITCH

This switch (6) is used to switch the head lamps between high beam and low beam.

Position (a): Low beam

Position (b): High beam

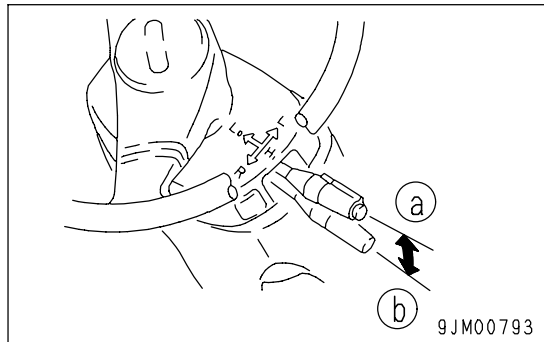

HORN BUTTON

When the horn button (7) in the center of the steering wheel is pressed, the horn will sound.

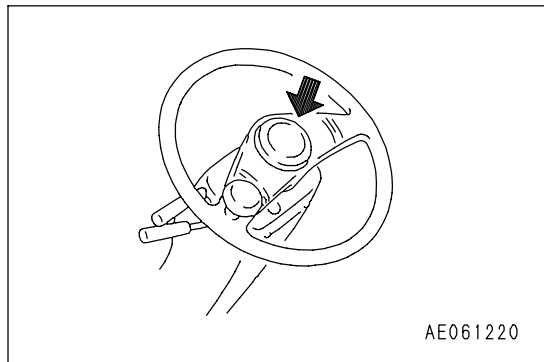

CONTROL LEVERS, PEDALS

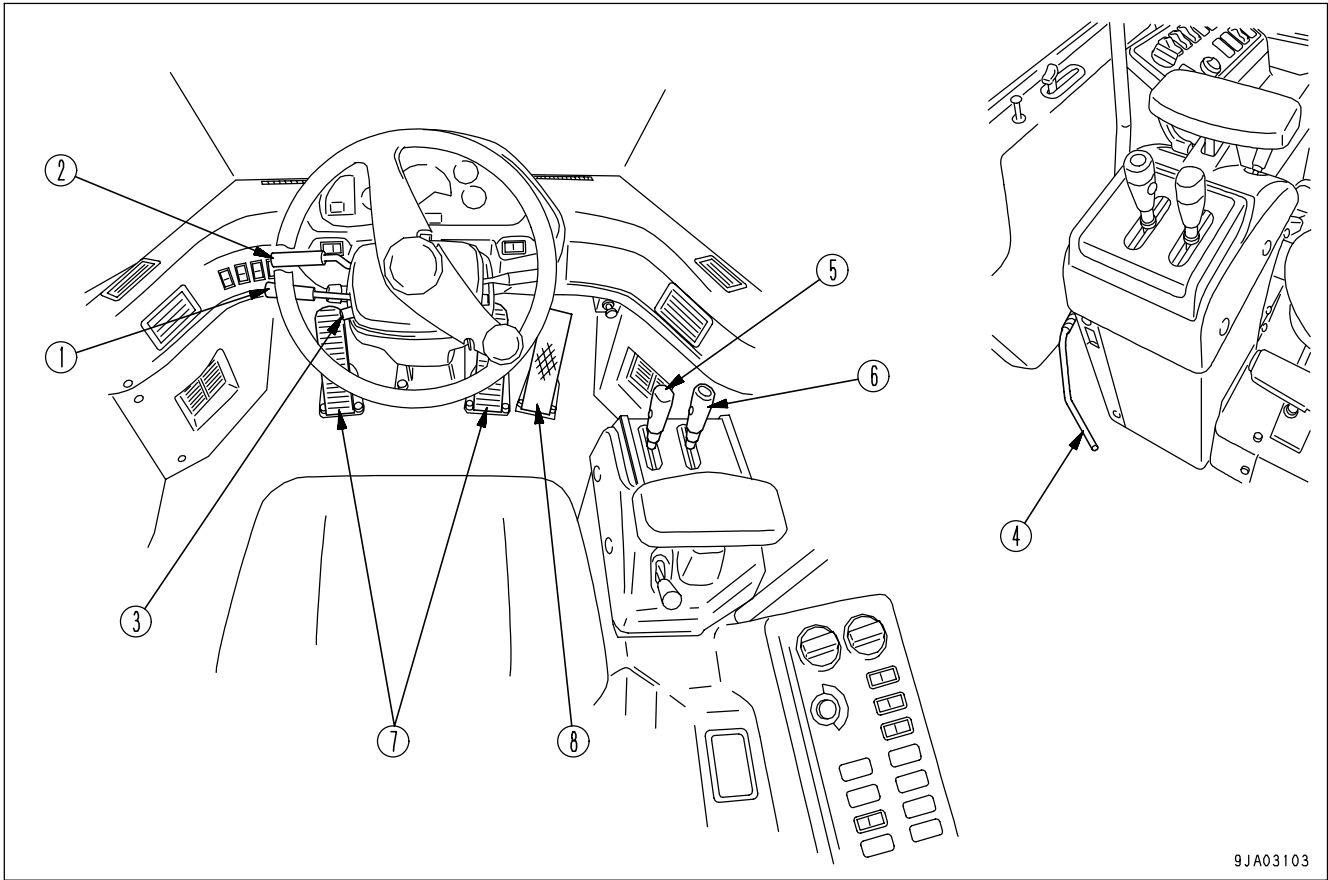

- (1) Gearshift lever
- (2) Directional lever
- (3) Gearshift lever stopper
- (4) Work equipment lock lever
- (5) Bucket control lever
- (6) Lift arm control lever
- (7) Brake pedal
- (8) Accelerator pedal

GEARSHIFT LEVER

This lever (1) changes the speed range of the transmission.

MANUAL SHIFT

This machine has a 4-FORWARD, 4-REVERSE speed transmission.

Place the gearshift lever in a suitable position to obtain the desired speed range.

1st and 2nd speeds are used for working.

3rd and 4th speeds are used for traveling.

However, when the gearshift lever stopper is being used, it is impossible to shift to 3rd or 4th. Disengage the gearshift lever stopper before trying to shift gear.

Position (a): 1st

Position (b): 2nd

Position (c): 3rd

Position (d): 4th

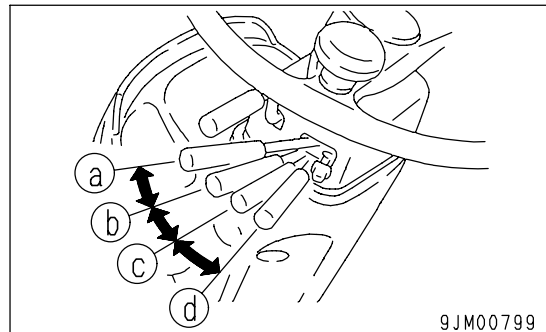

FUSE

NOTICE

Before replacing a fuse, be sure to turn off the starting switch.

The fuses protect the electrical equipment and wiring from burning out.

If the fuse becomes corroded, or white powder can be seen, or the fuse is loose in the fuse holder, replace the fuse.

Replace the fuse with another of the same capacity.

Loosen knob (1) at two places, then remove cover (2). The fuse boxes are A and B.

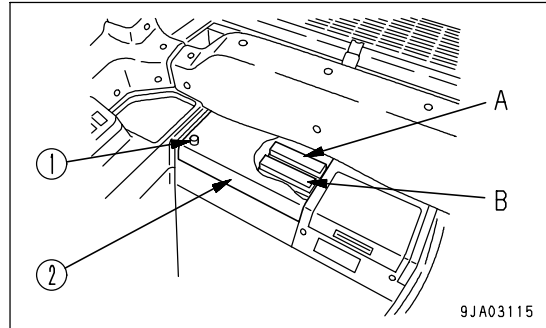

FUSE CAPACITY AND NAME OF CIRCUIT

FUSE BOX A

No.	Fuse capacity	Name of circuit
(1)	10A	Horn, air suspension
(2)	20A	Transmission control
(3)	10A	Parking brake
(4)	10A	Emergency steering
(5)	20A	Work equipment positioner
(6)	20A	Rear heated wire glass
(7)	20A	Wiper, washer
(8)	10A	Rotating lamp (if equipped)
(9)	10A	(KOMTRAX)
(10)	10A	Backup lamp, brake lamp
(11)	20A	Main lamp circuit
(12)	10A	Right side clearance lamp
(13)	10A	Left side clearance lamp
(14)	10A	Right head lamp
(15)	10A	Left head lamp

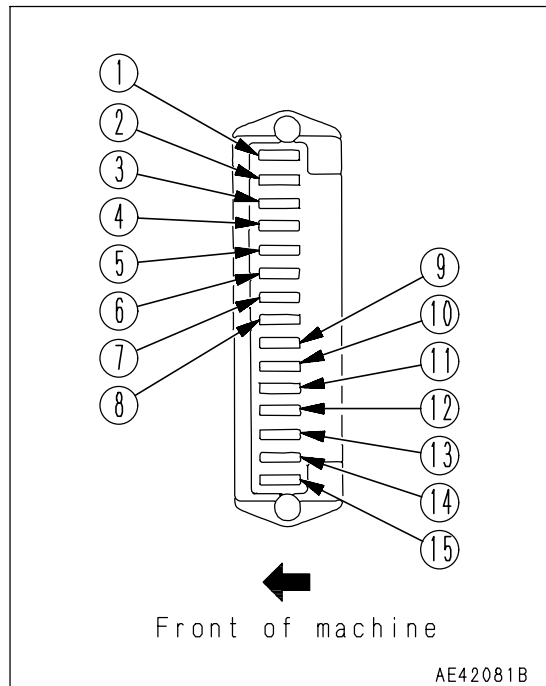

POWER SWITCH/VOLUME

Turn this knob (1) to the right until it clicks to turn the power on.
Turn it further to increase the volume.

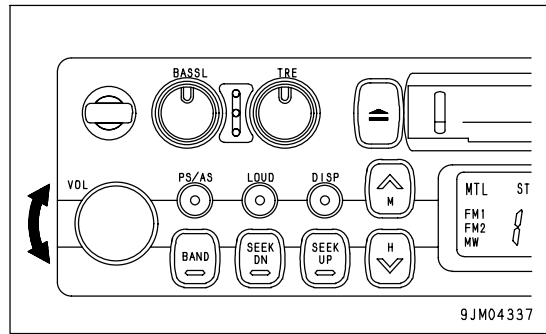

AUTO-STORE/PRESET SCAN BUTTON

Use this button (2) to actuate the preset scan and auto-store functions.

- Auto-store
Each time this button is pressed for more than 2 seconds while in radio reception, this auto-store function automatically starts to search for the desired station within a receivable band, and memorize the frequency in the preset memory. During this scanning process, the frequency shown in the right side of display continues to change. This indicates that each frequency is memorized in the auto-store.

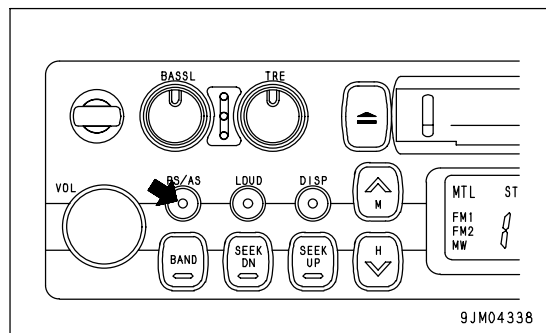

REMARK

The auto-store function cannot be used when the channel display is flashing.
When the display is flashing, the preset scan function is being used.

- Preset scan
If this button is pressed for less than 0.5 second while in radio reception, programs from the six preset stations in the same band will be broadcast one after another for 5 seconds each, starting from No. 1 through No. 6 stations consecutively.
When the desired station is found, press the button again. This stops the preset scan tuning process and switches to ordinary broadcasting. The same process will be repeated continuously until the button is pressed again.

BASS CONTROL KNOB

Turn this button (3) to the left to reduce the low tones; turn it to the right to emphasize the low tones.
Direction (a): Low tone reduced
Direction (b): Low tone emphasized

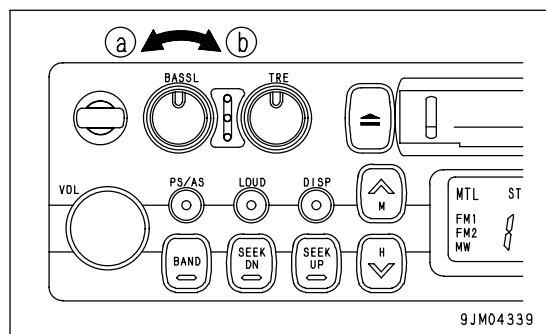

METHOD OF OPERATION

Switch		Condition of use				
		Fan switch	Air conditioner switch	Temperature control switch	FRESH/RECIRC selector switch	Mode selector switch
Cooling	Rapid	HI	ON	All blue	RECIRC	FACE
	Normal	HI - LO	ON	More than half are blue	FRESH	FACE
Dehumidifying, heating		HI - LO	ON	More than half are red	FRESH	FOOT
Heating	Rapid	HI	OFF	All red	RECIRC	FOOT
	Normal	HI - LO	OFF	More than half are red	FRESH	FOOT
Defroster		HI	ON	More than half are red	FRESH	DEF
Ventilation or pressurizing		HI - LO	OFF	All blue	FRESH	FACE

When defrosting, set the temperature control switch so that all lamps are red. This will improve defrosting and demisting.

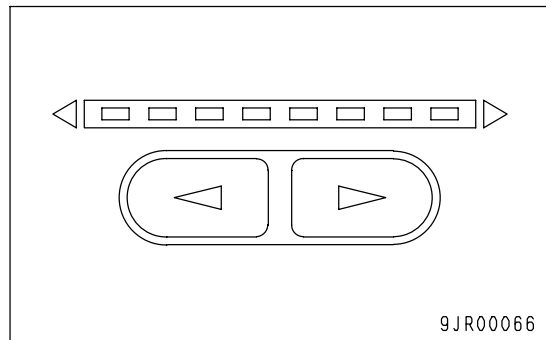

Set the vent mode selector switch to the intermediate position to give the desired condition. With the FACE vents, it is possible to adjust the direction of the air flow and to turn it on or off. However, do not set to the FACE mode with the vents closed.

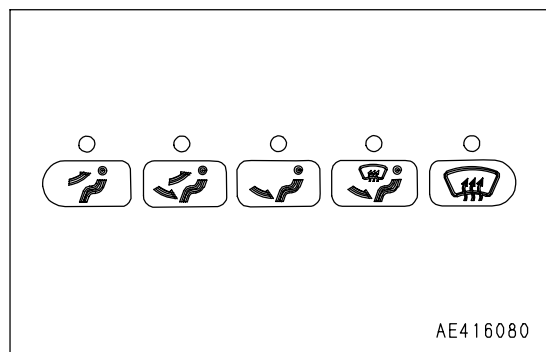

WHEN NOT USING THE AIR CONDITIONER REGULARLY

Run the air conditioner in cooling or dehumidification + heating mode for several minutes from time to time to prevent the loss of the oil film in various parts of the compressor.

REMARK

If the temperature inside the cab is low, the air conditioner may not work. In such cases, use the recirculated air to warm up the inside of the cab, then turn the air conditioner switch on. The air conditioner will be run.

OPERATION

CHECK BEFORE STARTING ENGINE, ADJUST

WALK-AROUND CHECK

Before starting the engine, walk around the machine and look at the underside of chassis for anything unusual like loose bolts and nuts, leakage of fuel, oil and coolant. Also check the condition of the work equipment and the hydraulic system.

Also check for loose wiring, play, and collection of dust at places that reach high temperature.



WARNING

Remove any flammable materials from around the battery, engine, muffler, turbocharger, or other high temperature engine parts. Leakage of fuel or oil will cause the machine to catch fire. Check carefully, be sure to repair any problem, or contact your Komatsu distributor.

If the machine is at an angle, reposition it level before checking.

Always perform the procedures in this section before starting the engine each day.

1. Check for damage, wear, play in work equipment, cylinders, linkage and hoses.
Check that there are no cracks, excessive wear, or play in the work equipment, cylinders, linkage, or hoses. If any abnormality is found, repair it.
2. Remove dirt and dust from around engine, battery and radiator.
Check if there is any dirt or dust accumulated around the engine or radiator. Also check if there is any flammable material (dead leaves, twigs, etc.) accumulated around the battery or high temperature engine parts, such as the engine muffler or turbocharger. Remove all such dirt or flammable material.
3. Check for coolant or oil leakage around the engine.
Check that there is no oil leakage from the engine or coolant leakage from the cooling system. If any problem is found, repair it.
4. Check for leakage of oil from transmission case, axle, hydraulic tank, hoses, joints.
Check that there is no oil leakage. If any abnormality is found, repair the leakage.
5. Check for oil leakage from the brake line.
Check that there is no oil leakage. If any abnormality is found, repair the leakage.
6. Check for damage or wear to tires and loose mounting bolts.
Check for cracks or peeling of the tires and for cracks or wear to the wheels (side rim, rim base, lock ring). Tighten any loose wheel nuts. If any abnormality is found, repair or replace the part.
If any valve caps are missing, install new caps.
7. Check for damage and loose bolts on the handrail and steps.
Repair any damage and tighten any loose bolts.
8. Check for damage to gauges, lamps on the instrument panel and loose bolts.
Check for damage to the panel, gauges and lamps. If any problem is found, replace the parts. Clean off any dirt on the surface. Tighten any loose bolts.

(D) Adjusting fore-and-aft position of seat cushion

Push in lever (4), set the seat cushion to the desired position, then release the lever.

Amount of adjustment: 60 mm (2.4 in)

(E) Setting seat for weight

Sit on the seat, raise your body slightly, then operate switch (5) to adjust the strength of the suspension.

Amount of adjustment: 50 - 130 kg (110 - 287 lb)(target)

When + is pressed: Suspension becomes stronger

When - is pressed: Suspension becomes weaker

(F) Adjusting reclining angle

Move lever (6) up and move the backrest to the front or rear.

Push your back against the backrest when carrying out this adjustment. If your back is not pressing against the backrest, the backrest may suddenly spring forward.

Amount of adjustment: Front tilt: Free

Rear tilt: 40 degrees (2 degrees x 20 stages)

(G) Adjusting headrest angle (if equipped)

Rotate the headrest to the front or rear.

Amount of adjustment:

Front tilt: 13 degrees

Rear tilt: 13 degrees

(H) Adjusting headrest height (if equipped)

Move the headrest up or down.

Amount of adjustment: 80 mm (3.2 in)

(I) Adjusting armrest angle

Rotate the knob (7) and adjust the angle of the armrest. (Left side only)

Amount of adjustment: 73 degrees (front: 54 degrees; rear: 19 degrees)

If the arm rest is turned, it will spring up. (Both left and right sides)

(J) Lumbar support

Operate switch (8) to give a suitable tension to the lower lumbar region.

Operate switch (9) to give a suitable tension to the upper lumbar region.

When + is pressed: Tension becomes stronger

When - is pressed: Tension becomes weaker

(K) Side support

Operate switch (10) to give a suitable tension to the left and right lumbar region.

When + is pressed: Tension becomes stronger

When - is pressed: Tension becomes weaker

AUTOMATIC WARMING-UP OPERATION

After the engine starts, if the engine water temperature is low (below 20°C (68°F)), the warming-up operation (engine speed: 1130 rpm) is automatically carried out. When the water temperature goes above 50°C (122°F), the warming-up operation is canceled.

REMARK

The automatic warming-up operation changes as shown in the diagram on the right according to the engine water temperature.

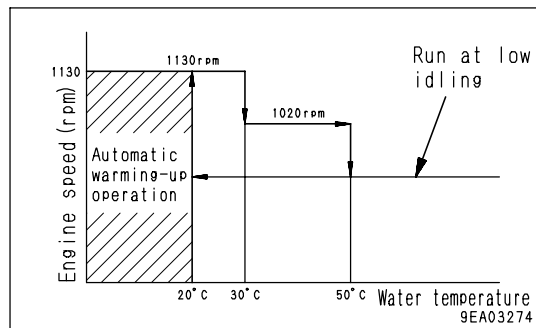

CLICK HERE TO **DOWNLOAD** THE COMPLETE MANUAL

- Thank you very much for reading the preview of the manual.
- You can download the complete manual from: www.heydownloads.com by clicking the link below



- Please note: If there is no response to CLICKING the link, please download this PDF first and then click on it.

CLICK HERE TO **DOWNLOAD** THE COMPLETE MANUAL

2. Turn on directional selector switch on the right side of switching panel that enables directional selection.

Position (a): ON

Position (b): OFF

The two pilot lamps light up, i.e. one is the pilot lamp built in the actuating switch and another is the directional selector pilot lamp on the machine monitor.

Then the actuating switch enables the forward - reverse shifting to function.

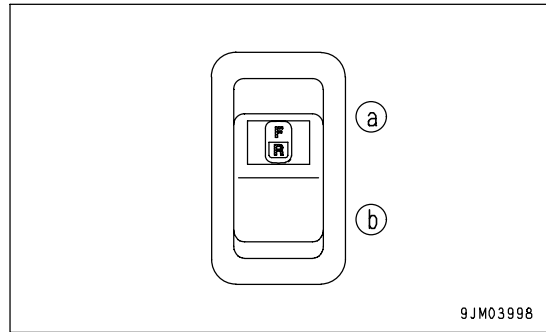

9JM03998

If the switch or the lever is in one of the following conditions, set it to the correct position.

- When directional lever is not at N position
If the directional lever is not at the N position, the pilot lamp flashes, and at the same time, the central warning lamp lights up and the alarm buzzer sounds.
In this condition, the machine will move forward or in reverse according to the set position of the directional lever.
Return the directional lever to the N position.
- When directional selector switch is at F or R when engine is started
If the directional selector switch is at F or R, the central warning lamp lights up and the alarm buzzer sounds.
In this condition, the engine will not start, so set the directional selector switch to N.

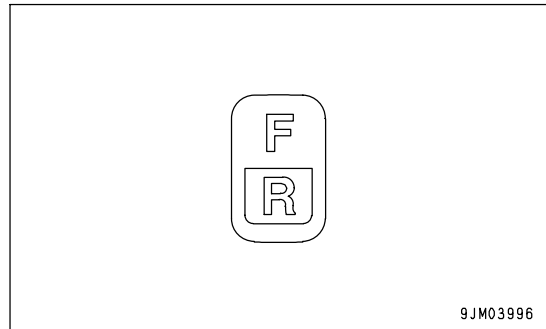

9JM03996

3. Press the directional selector switch on the side of the work equipment control lever to the desired position.

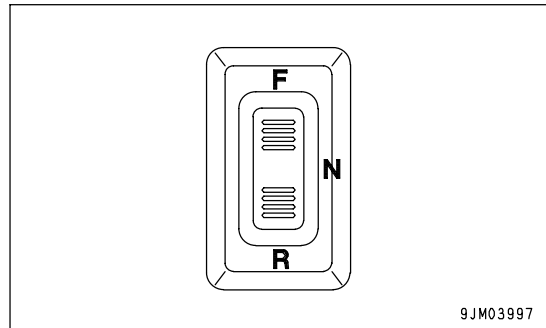

9JM03997

6. If there is too much material loaded in the bucket, dump and tilt the bucket quickly to remove the excessive load. This prevents spillage of the load during hauling.

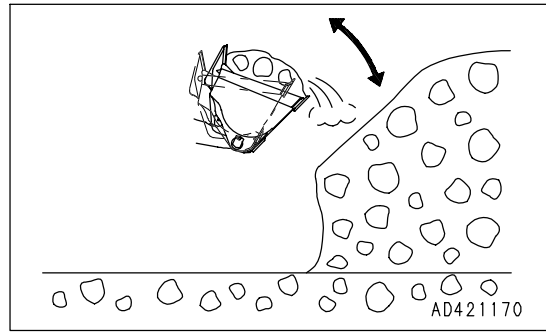

DIGGING AND LOADING ON LEVEL GROUND

- When digging and loading on level ground, set the bucket edge facing down slightly as follows and drive the machine forward. Always be careful not to load the bucket on one side and cause an unbalanced load. This operation should be carried out in 1st gear.

 **CAUTION**

Do not set the bucket facing down more than 20 degrees.

1. Set the edge of the bucket facing slightly down.

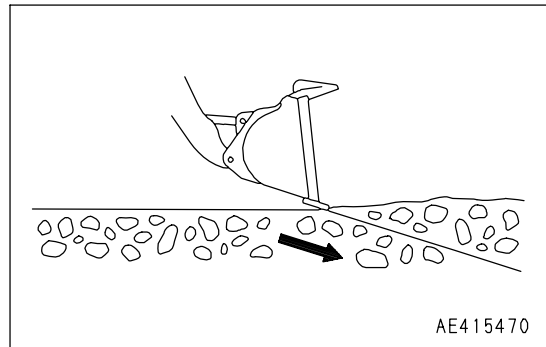

2. Drive the machine forward and operate the lift arm control lever forward to cut a thin layer of the surface each time when excavating the soil.

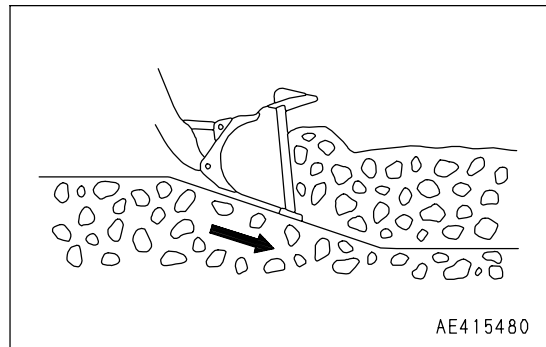

3. Operate the lift arm control lever slightly up and down to reduce the resistance when driving the machine forward.

When digging with the bucket, avoid imposing the digging force on one side of the bucket.

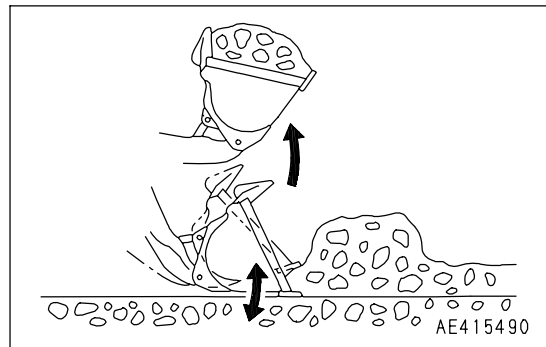

CHECKS AFTER COMPLETION OF OPERATION

BEFORE STOPPING ENGINE

Check the engine water temperature, engine oil pressure, torque converter oil temperature, and fuel level with the machine monitor.

If the engine has overheated, do not stop it suddenly. Run the engine at a midrange speed to allow the engine to cool down before stopping it.

AFTER STOPPING ENGINE

1. Walk around the machine and check the work equipment, bodywork, and undercarriage, and check also for oil and water leakage.
2. Fill the fuel tank.
3. Check the engine compartment for paper and debris. Clean out any paper and debris to avoid a fire hazard.
4. Remove any mud affixed to the undercarriage.

LOCKING

Always lock the following parts.

- (1) Fuel tank filler cap
- (2) Engine side panel (2 points)
- (3) Cab door (2 points)

REMARK

The starting switch key is used also for locks (1), (2), and (3).

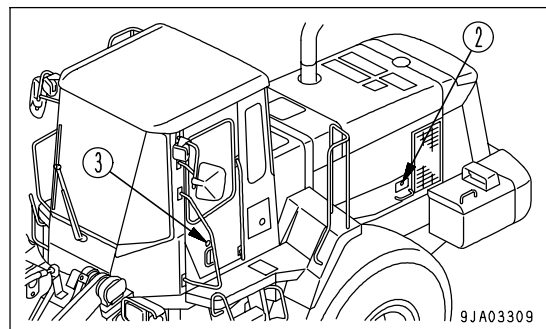
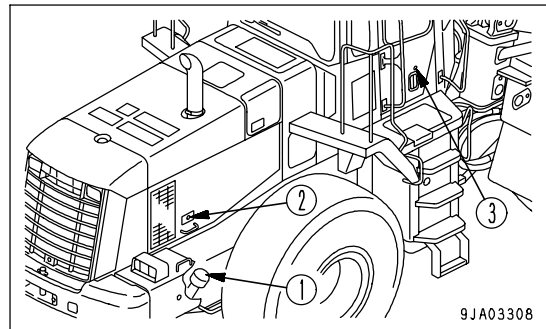

BATTERY

 **WARNING**

- The battery generates flammable gas. Do not bring fire or sparks near the battery.
- Battery electrolyte is dangerous. If it gets in your eyes or on your skin, wash it off with a large amount of water and consult a doctor.
- Battery electrolyte dissolves paint. If it gets on the bodywork, wash it off immediately with water.
- If the battery electrolyte is frozen, do not charge the battery or start the engine with a different power source. There is danger that the battery may explode.
- Battery electrolyte is toxic. Do not let it flow into drainage ditches or spray it on to the ground surface.

When the ambient temperature drops, the capacity of the battery will also drop. If the battery charge ratio is low, the battery electrolyte may freeze. Maintain the battery charge as close as possible to 100%. Insulate it against cold temperature to ensure the machine can be started easily the next morning.

REMARK

Measure the specific gravity and calculate the charging rate from the following conversion table.

Charging Rate (%)	Electrolyte Temperature	20°C (68°F)	0°C (32°F)	-10°C (14°F)	-20°C (-4°F)
	100		1.28	1.29	1.30
90		1.26	1.27	1.28	1.29
80		1.24	1.25	1.26	1.27
75		1.23	1.24	1.25	1.26

- As the battery capacity drastically drops in low temperatures, cover or remove the battery from the machine, store the battery in a warm place, and install it again the next morning.
- If the electrolyte level is low, add distilled water in the morning before beginning work. Do not add water after the day's work to prevent diluted electrolyte in the battery from freezing during the night.

PRECAUTIONS AFTER COMPLETION OF WORK

To prevent mud, water, or the undercarriage from freezing and making it impossible for the machine to move on the following morning, observe the following precautions.

- Remove all the mud and water from the machine body. In particular, wipe the hydraulic cylinder rods clean to prevent damage to the seal caused by mud, dirt, or drops of water on the rod from getting inside the seal.
- Park the machine on hard, dry ground.
If this is impossible, park the machine on boards.
The boards prevent the tracks from freezing to the ground, and allow the machine to be moved the next morning.
- Open the drain valve and drain any water collected in the fuel system to prevent it from freezing.
- Fill the fuel tank to capacity. This minimizes moisture condensation in the tank when the temperature drops.

AFTER COLD WEATHER

When the season changes and the weather becomes warmer, do as follows.

- Replace all fuel and oil with fuel and oil of the specified viscosity. For details, see "RECOMMENDED FUEL, COOLANT, AND LUBRICANT (PAGE 4-9)".

PRECAUTIONS FOR CHARGING BATTERY

When charging the battery, if the battery is not handled correctly, there is danger that the battery may explode. Always follow the instructions in "BATTERY (PAGE 3-150)" and the instruction manual accompanying the charger, and do as follows.

- Do not use or charge the battery if the battery electrolyte level is below the LOWER LEVEL line. This may cause an explosion. Check the battery electrolyte level periodically and add distilled water to bring the electrolyte level to the UPPER LEVEL line.
- Set the voltage of the charger to match the voltage of the battery to be charged. If the correct voltage is not selected, the charger may overheat and cause an explosion.
- Connect the positive (+) charger clip of the charger to the positive (+) terminal of the battery, then connect the negative (-) charger clip of the charger to the negative (-) terminal of the battery. Be sure to attach the clips securely.
- Set the charging current to 1/10 of the value of the rated battery capacity; when carrying out rapid charging, set it to less than the rated battery capacity.
If the charger current is too high, the electrolyte will leak or dry up, and this may cause the battery to catch fire and explode.
- If the battery electrolyte is frozen, do not charge the battery or start the engine with a different power source. There is a danger that this will ignite the battery electrolyte and cause the battery to explode.

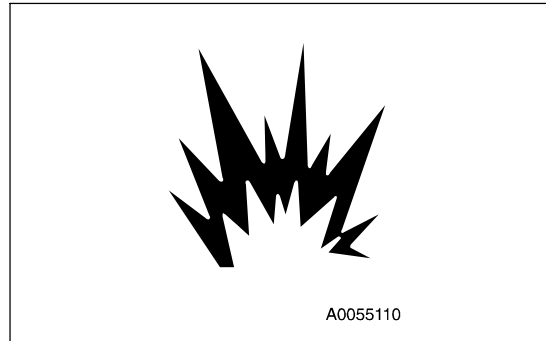

STARTING ENGINE WITH BOOSTER CABLE

When starting the engine with a booster cable, do as follows.

PRECAUTIONS WHEN CONNECTING AND DISCONNECTING BOOSTER CABLE



WARNING

- When connecting the cables, never contact the positive (+) and negative (-) terminals.
- When starting the engine with a booster cable, wear safety glasses and rubber gloves.
- Be careful not to let the normal machine and problem machine contact each other. This prevents sparks from generating near the battery which could ignite the hydrogen gas given off by the battery.
- Make sure that there is no mistake in the booster cable connections. The final connection is to the engine block of the problem machine, but sparks will be generated when this is done, so connect to a place as far as possible from the battery.
- When disconnecting the booster cable, take care not to bring the clips in contact with each other or with the machine body.

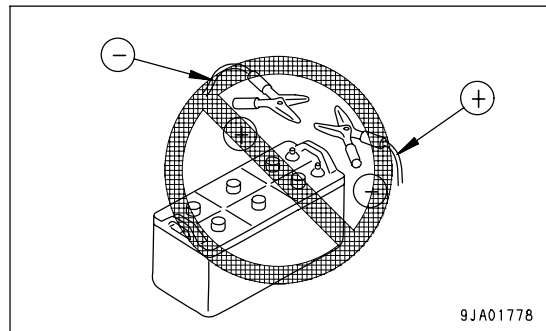

NOTICE

- Use a booster cable and clip of a thickness to match the size of the battery.
- The battery on the normal machine must be the same capacity as the battery on the failed machine.
- Check that there is no breakage or corrosion of the cable or clip.
- Connect the clip securely.
- Check that the work equipment lock levers on both the machines are at the LOCK position and that the parking brake is applied.
- Check that all levers are at the Neutral position.

OUTLINES OF SERVICE

- Always use Komatsu genuine parts for replacement parts, grease or oil.
- When changing the oil or adding oil, do not mix different types of oil. When changing the type of oil, drain all the old oil and fill completely with the new oil. Always replace the filter at the same time. (There is no problem if the small amount of oil remaining in the piping mixes with the new oil.)
- Unless otherwise specified, when the machine is shipped from the factory, it is filled with the oil and coolant listed in the table below.

Item	Type
Engine oil pan	Engine oil EO15W40DH (Komatsu genuine parts)
Transmission case	Power train oil TO10 (Komatsu genuine parts)
Hydraulic oil system	Power train oil TO10 (Komatsu genuine parts)
Axle	Axle oil AXO80 (Komatsu genuine parts)
Radiator	Supercoolant AF-NAC (density: 30% or above) (Komatsu genuine parts)

HANDLING OIL, FUEL, COOLANT, AND PERFORMING OIL CLINIC

OIL

- Oil is used in the engine and hydraulic equipment under extremely severe conditions (high temperature, high pressure), and deteriorates with use.
Always use oil that matches the grade and maximum and minimum ambient temperatures recommended in the Operation and Maintenance Manual. Even if the oil is not dirty, always change the oil at the specified interval.
- Oil corresponds to blood in the human body, always be careful when handling it to prevent any impurities (water, metal particles, dirt, etc.) from getting in.
The majority of problems with the machine are caused by the entry of such impurities.
Take particular care not to let any impurities get in when storing or adding oil.
- Never mix oils of different grades or brands.
- Always add the specified amount of oil.
Having too much oil or too little oil are both causes of problems.
- If the oil in the work equipment is not clear, there is probably water or air getting into the circuit. In such cases, please contact your Komatsu distributor.
- When changing the oil, always replace the related filters at the same time.
- We recommend you have an analysis made of the oil periodically to check the condition of the machine. For those who wish to use this service, please contact your Komatsu distributor.
- When using commercially available oil, it may be necessary to reduce the oil change interval.
We recommend that you use the Komatsu oil clinic to carry out a detailed checks of the characteristics of the oil.

MAINTENANCE SCHEDULE CHART

MAINTENANCE SCHEDULE CHART

The maintenance interval for adjusting the injector differs according to the exhaust gas regulations for each area. When carrying out the adjustment, check the maintenance time. For details, see "ADJUST INJECTOR (PAGE 4-16)".

INITIAL 250 HOURS SERVICE (ONLY AFTER THE FIRST 250 HOURS)

CHANGE TRANSMISSION OIL FILTER CARTRIDGE	4- 55
REPLACE HYDRAULIC TANK FILTER ELEMENT	4- 60

WHEN REQUIRED

CHECK, CLEAN, OR REPLACE AIR CLEANER ELEMENT	4- 18
CLEAN INSIDE OF COOLING SYSTEM	4- 22
CHECK WATER SEPARATOR, DRAIN WATER	4- 25
CHECK TRANSMISSION OIL LEVEL, ADD OIL	4- 26
CHECK AXLE OIL LEVEL, ADD OIL	4- 27
CHECK AXLE CASE BREATHER	4- 28
CLEAN CONDENSER OF AIR CONDENSER	4- 29
CHECK WINDOW WASHING FLUID LEVEL, ADD FLUID	4- 29
CLEAN RADIATOR FINS AND COOLER FINS	4- 30
CHECK ELECTRICAL INTAKE AIR HEATER	4- 33
TURN, REPLACE BOLT ON CUTTING EDGE	4- 34
REPLACE BUCKET TEETH	4- 34
CHECK AIR CONDITIONER	4- 36
REPLACE SLOW-BLOW FUSE	4- 37
CHECKING FUNCTION OF ACCUMULATOR	4- 38
SELECTION AND INSPECTION OF TIRES	4- 39

CHECK BEFORE STARTING

EVERY 50 HOURS SERVICE

DRAIN WATER, SEDIMENT FROM FUEL TANK	4- 42
--	-------

EVERY 100 HOURS SERVICE

LUBRICATE REAR AXLE PIVOT PIN	4- 43
CHECK OIL LEVEL IN HYDRAULIC TANK, ADD OIL	4- 43
CLEAN ELEMENT IN AIR CONDITIONER FRESH AIR FILTER	4- 44

EVERY 250 HOURS SERVICE

CHECK ENGINE ELECTROLYTE LEVEL	4- 45
CHECK PARKING BRAKE	4- 47
CHECK ALTERNATOR BELT TENSION, ADJUST	4- 47
CHECK AIR CONDITIONER COMPRESSOR BELT TENSION, ADJUST	4- 48
CHECK FOR LOOSE WHEEL HUB BOLTS, TIGHTEN	4- 49
CLEAN ELEMENT IN AIR CONDITIONER RECIRCULATION FILTER	4- 49
CHECKING FUNCTION OF ACCUMULATOR	4- 50
LUBRICATING	4- 51

4. Set a container in position to catch the drained antifreeze mixture, then open drain valve (3) under the left side of the fuel tank and drain plug (4) at the side face of the cylinder block, and drain the coolant.
5. After draining the coolant, close drain valve (3) and drain plug (4) and fill with city water.
6. When the radiator is full, start the engine, and run it at low idle. Keep the engine running at low idle for 10 minutes until the coolant temperature reaches more than 90°C (194°F).
7. Stop the engine, open drain valve (3) and drain plug (4), drain the water, then tighten them again.
8. After draining the water, clean the cooling system with cleaning agent. For the cleaning method, see the instructions for the cleaning agent.
9. Replace the corrosion resistor, then open 2 valves (1). For details of the procedure for replacing the corrosion resistor, see "REPLACE CORROSION RESISTOR CARTRIDGE (PAGE 4-57)".
10. Add coolant mixed with antifreeze until it overflows from the water filler.
11. To bleed the air from the cooling system, run the engine at low idle for 5 minutes, and for a further 5 minutes at high idle. (When doing this, leave the radiator cap off.)
12. Drain the coolant from sub-tank (5), clean the inside of the sub-tank, then add water until the coolant level is between the FULL and LOW marks.
13. Stop the engine, wait for approx. 3 minutes, then add coolant until the coolant level is near the coolant filler port, and tighten the cap. Check the coolant level and add coolant if necessary.

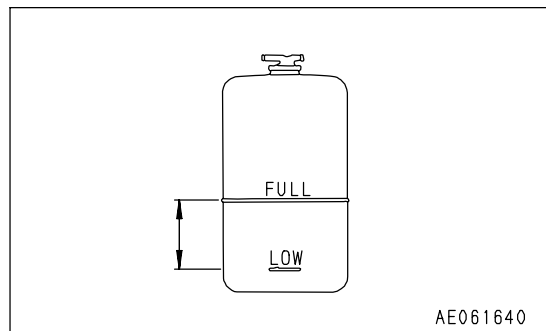
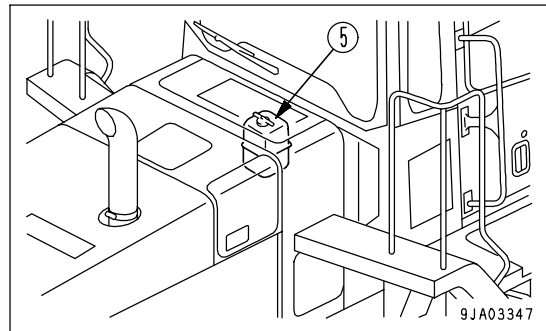
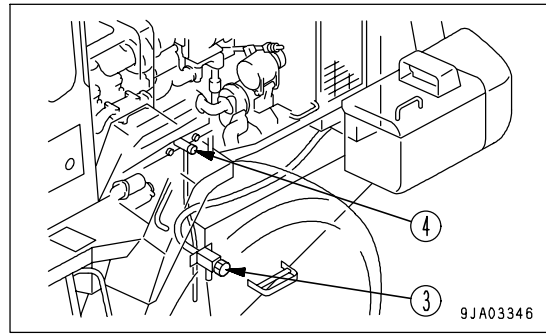

TURN, REPLACE BOLT-ON CUTTING EDGE



WARNING

It is dangerous if the work equipment moves by mistake during the turning or replacement operation.

Set the work equipment in a stable condition, stop the engine, then set the work equipment lock lever securely to the LOCK position.

Turn or replace the cutting edge before the wear reaches the edge of the bucket.

1. Raise the bucket to a suitable height, then put blocks (A) under the bucket to prevent the bucket from coming down.
Raise the bucket so that the bottom surface of the bucket is horizontal.
2. Remove nuts and bolts (1), then remove cutting edge (2).
3. Clean the mounting surface of cutting edge (2).
4. Turn cutting edge (2) and install it to the bucket. When turning the edge, install it to the opposite side (left edge to right side, right edge to left side).

If both sides of the cutting edge are worn, replace with a new part.

If the wear extends to the mounting surface, repair the mounting surface before installing the cutting edge.

5. Tighten nuts and bolts (1) uniformly so that there is no gap between the bucket and cutting edge.
Tightening torque for mounting bolt: $745 \pm 108 \text{ Nm}$ ($76 \pm 11 \text{ kgm}$, $549.7 \pm 79.6 \text{ lbft}$)
6. Tighten the mounting bolts again after operating for several hours.

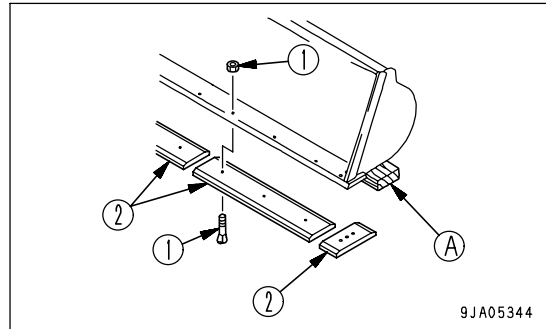

REPLACE BUCKET TEETH

(If equipped)

ONE-PIECE TOOTH

When the bucket teeth are worn, replace them as follows.

1. Raise the bucket to a suitable height, then put blocks (A) under the bucket to prevent the bucket from coming down.
Raise the bucket so that the bottom surface of the bucket is horizontal.
2. Remove the bolt and nuts (1) and (2), then remove bucket tooth (3).
3. Clean the installation surface of bucket tooth (3).
4. Install new teeth to the bucket.

When doing this, insert shims so that there is no clearance between the teeth and the top surface of the bucket.

Continue to add shims until it becomes impossible to add a 0.5 mm (0.02 in) shim.

If the mounting surface is worn, correct the mounting surface before installing the teeth.

5. To prevent any gap from forming between the teeth and tip of the bucket, tighten bolts and nuts (1) and (2) temporarily, then hit the tip of the teeth with a hammer.
Tightening torque of mounting bolt (1): $863 \pm 941 \text{ Nm}$ ($88 \pm 96 \text{ kgm}$, $636.5 \pm 694.4 \text{ lbft}$)
(2): $588 \pm 647 \text{ Nm}$ ($60 \pm 66 \text{ kgm}$, $434 \pm 477.4 \text{ lbft}$)
6. After operating the machine for a few hours, tighten the mounting bolts again.

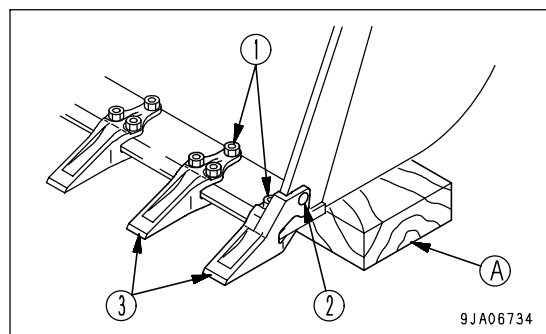

CLEAN ELEMENT IN AIR CONDITIONER FRESH AIR FILTER

(Machine equipped with cab) (If equipped)

**WARNING**

If compressed air scattered around dust and debris, there is danger of injury. Always wear protective equipment such as protective glasses and mask.

If the air conditioner has been used, the air filter should be cleaned.

Stop the air conditioner before cleaning the element.

1. Push handle (1) and open cover (2).

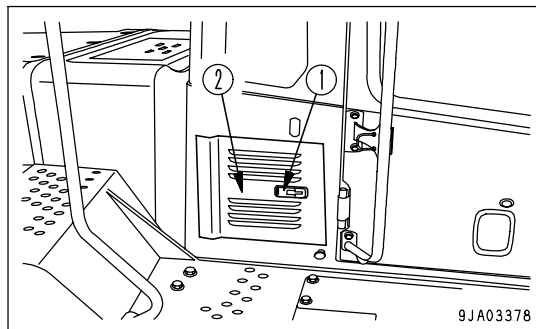

2. Remove element (3) and clean it.
3. Direct dry compressed air (less than 0.69 MPa (7 kg/cm², 99.4 PSI)) to the element from inside along its folds, then direct it from outside along its folds and again from inside.

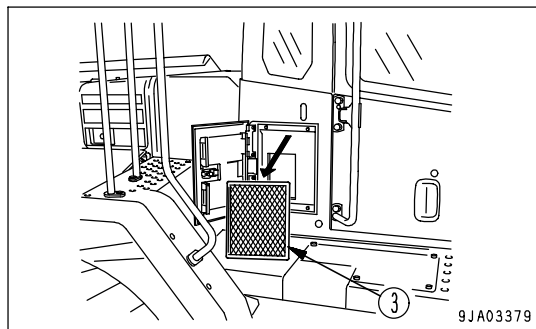

NOTICE

- When adding fuel, do not remove cap (B). Always add fuel from the 8 small holes (A) on the dirty side.
- After adding fuel, remove cap (B) and install the fuel filter.
- Always fill with clean fuel. Be careful not to let any dirt or dust get into the fuel. In particular, center portion is the clean side, so do not remove cap (B) when adding fuel. Be careful not to let dirt or dust get into center portion on the clean side.

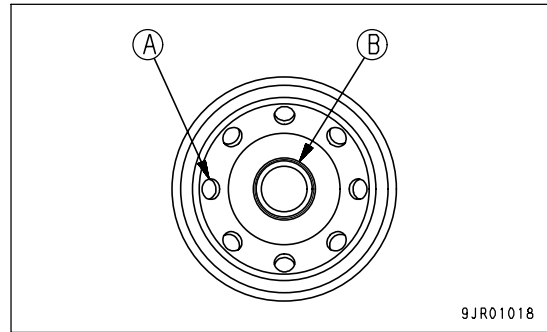

7. When installing, tighten until the packing surface contacts the seal surface of the filter holder, then tighten it 3/4 of a turn.
If the filter cartridge is tightened too far, the packing will be damaged and this will lead to leakage of fuel. If the filter cartridge is too loose, fuel will also leak from the packing, so always tighten the correct amount.
 - When tightening with a filter wrench, be extremely careful not to dent or damage the filter.
8. After completion of the replacement of fuel filter cartridge (1), bleed the air.
Bleed the air as follows:
9. Add fuel to the fuel tank until full (to FULL mark on the fuel gauge).
10. After replacing filter cartridge (1), loosen air bleed plug (3) and add fuel until no more bubbles come out in the fuel from the air bleed plug.
11. After replacing the filter cartridge, start the engine and check for any leakage of fuel from the filter seal surface.

CLEAN PPC CIRCUIT STRAINER



WARNING

- After the engine is stopped, the parts and oil are at high temperature, and may cause burns. Wait for the temperature to go down before starting the operation.
- When the rubber hose is removed, oil may spurt out, so turn it slowly to release the internal pressure, then remove it carefully.

1. When rubber hose (1) and flange (2) are removed, oil will spill out, so set a container (capacity: approx. 300 cc) in position to catch the oil.
2. Remove rubber hose (1) and flange (2).
3. Remove strainer (3) and wash it in clean diesel oil.
4. Install strainer (3) in strainer case (4) from the concave side, then install with flange (2).

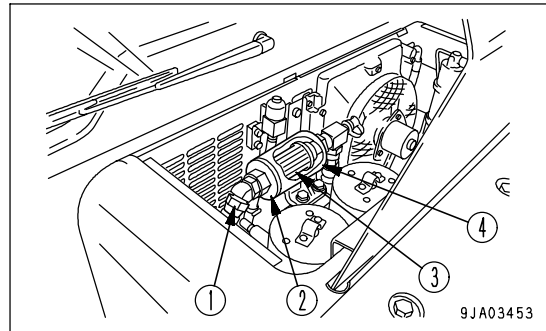

REMARK

Assemble with the protruding side (O-ring side) of the strainer at the front

5. Install rubber hose (1).

CLEAN ENGINE BREATHER ELEMENT



WARNING

- The parts and oil are at high temperature after the engine is stopped, and may cause serious burns. Wait for the temperature to go down before cleaning the engine breather.
- When using compressed air, there is a hazard that dirt may be blown up and cause serious injury. Always use safety glasses, dust mask, or other protective equipment.

1. Wipe away dust around the breather.
2. Loosen the clamp and remove the hose. Remove breather (1).
3. Clean the breather body with light oil or cleaning oil.
4. Replace O-ring with new one. Coat a new O-ring with engine oil, set it, then install breather (1).
5. Check the breather hose and pipe. If caked oil (sludge) adhere to insides, replace the hose and pipe with new parts.

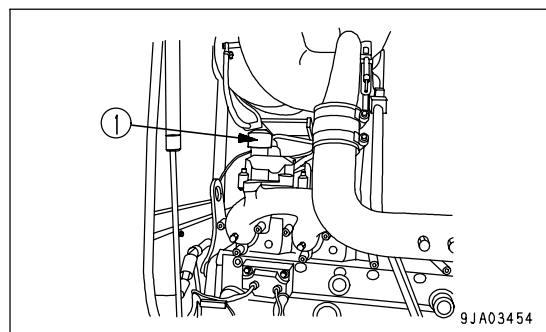

HANDLING LOAD METER

GENERAL LOCATIONS

MACHINE MONITOR WITH LOAD METER

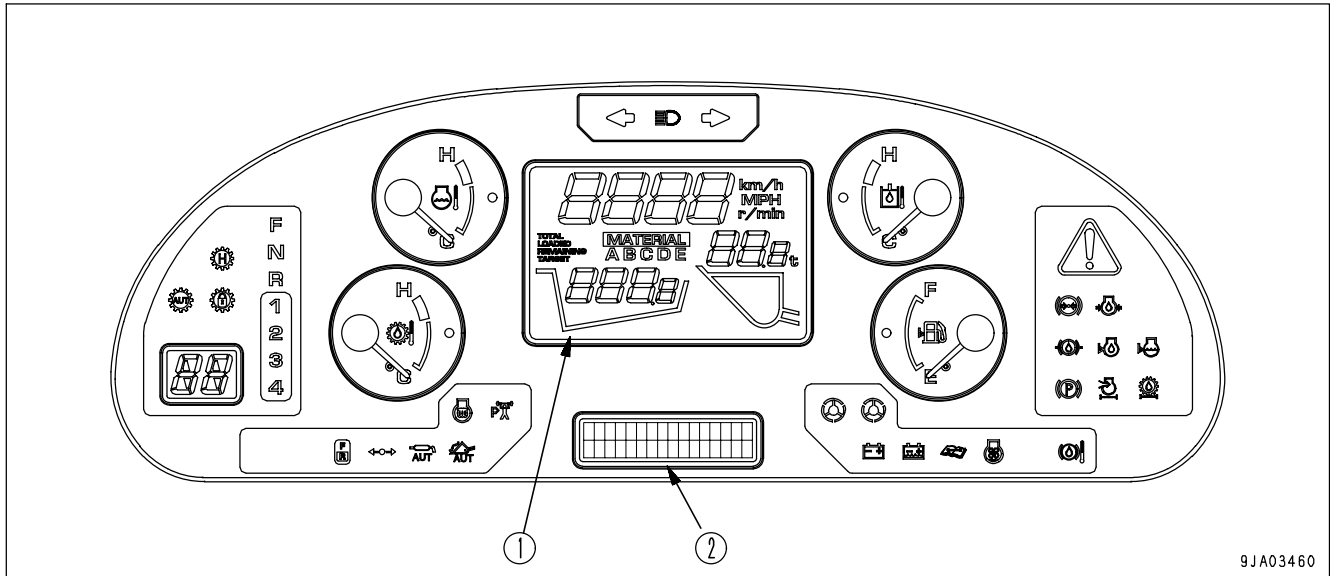

(1) Load meter display

(2) Character display

The only difference from the machine monitor described in EXPLANATION OF COMPONENTS in the OPERATION section is that the load meter panel is installed in place of the speedometer and meter display pilot lamp.

For details of items not given here, see "MACHINE MONITOR (PAGE 3-6)" in the OPERATION section.

TOTAL LOAD DATA DISPLAY

1. Check that the normal service meter and time are displayed on the character display.

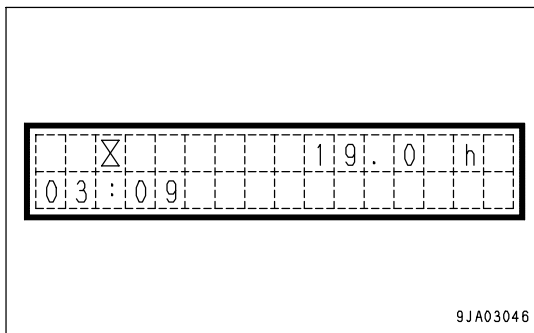

2. Press the (◇) of monitor panel selector switch 1 and display "LOAD METER".

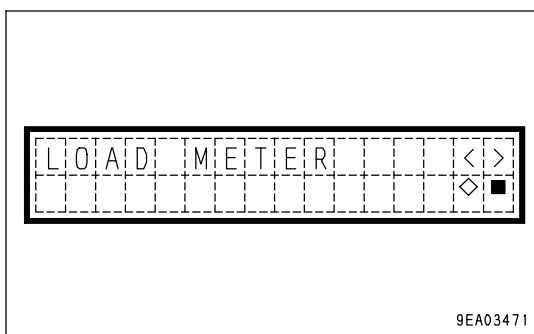

3. Press the (◇) of monitor panel selector switch 1, then press the (>) or (<) of monitor panel mode selector switch 2 to display "DATA".

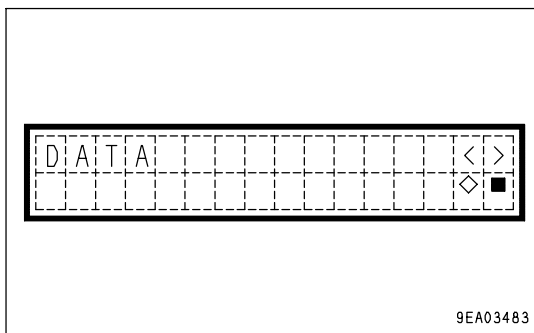

4. Press the (◇) of monitor panel selector switch 1 to display "TOTAL DATA".

The time when the load on the bottom line was calculated is displayed as the hour meter standard.

5. Press the (>) or (<) of monitor panel mode selector switch 2 to select the data for each of A to E or the all lighted-up display.

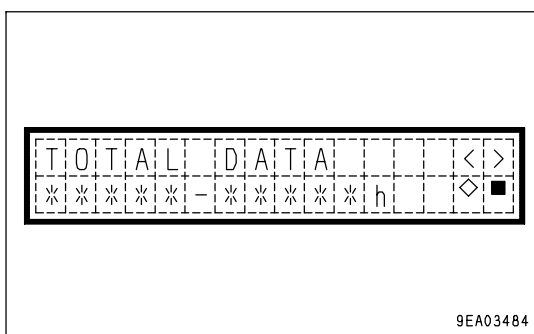

METHOD OF SETTING TIME ON CLOCK

(The time display is only available on machines equipped with the load meter)

1. Check that the normal service meter and time are displayed on the character display.

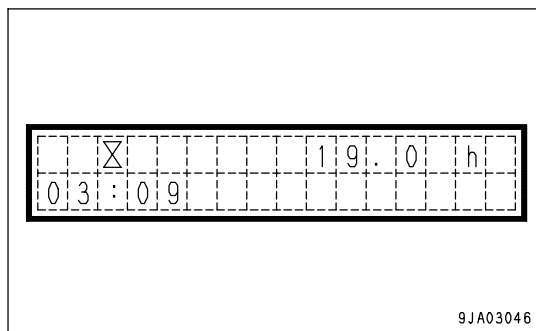

2. Press the (◇) of monitor panel selector switch 1 and display "LOAD METER".

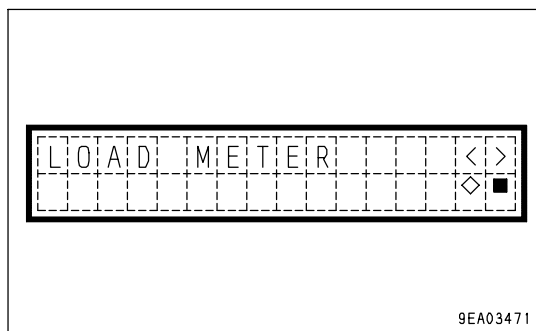

3. Press the (◇) of monitor panel mode selector switch 1, then press the (>) or (<) of monitor panel mode selector switch 2 to select "DAY & TIME ADJUST".

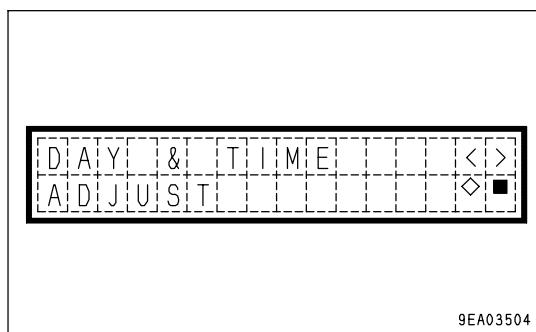

4. Press the (◇) of monitor panel mode selector switch 1.
The top line displays "ADJUST 23: 59".
The bottom line displays "2000/01/01".

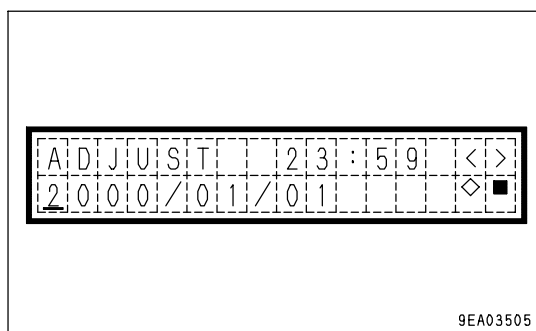

REMARK

Once the time is input, the clock will show the correct time from that time on.

5. Input the day and time.
The cursor is displayed at each input item in the following order: Year, Month, Day, Hour, Minute.
Use the (>) or (<) of monitor panel mode selector switch 2 to move the numbers up or down and input numbers between 0 and 9 at the cursor position.
6. After inputting the number, press the (◇) of monitor panel mode selector switch 1 to select and move the cursor to the next input position.
Repeat Steps 5 and 6 to input and select the numbers from the year to the minute.

PILOT LAMP DISPLAY ON MACHINE MONITOR

The display of pilot lamp (2) on the machine monitor lights up or flashes according to the following conditions.

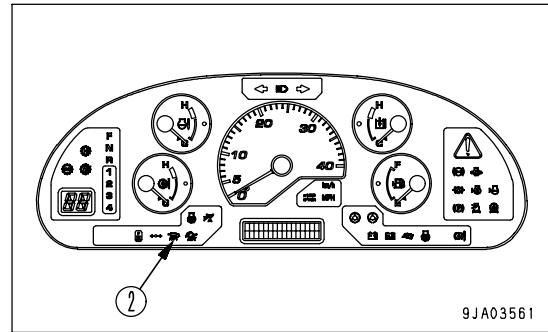

Lighted up: Normal operation

1 flash per sec: Grease cartridge empty

1 flash per 0.5 sec: Defective decompression, pump pressurized, pressure detected, fuse blown

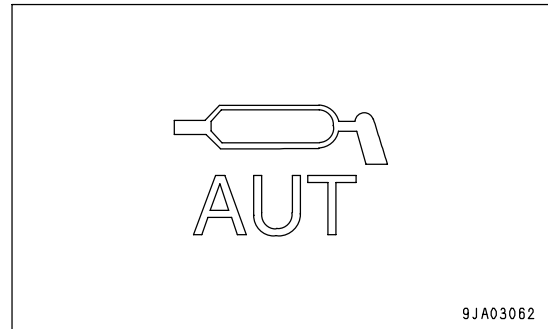

SETTING GREASING TIME

The set time and greasing frequency limit differs according to the operating condition and greasing plan for the machine, so set the following items to carry out suitable centralized greasing.

- Greasing interval (Hr): Greasing interval for automatic operation
- Greasing time (min): Length of time pump is operated for each greasing operation
- Greasing frequency limit (times): No. of times for operating pump before the 1000 cc grease cartridge becomes empty

The settings when shipping from the factory are as follows.

Greasing interval: 3 hours

Greasing time: 7 minutes

Greasing frequency limit: 100 times

The grease level alarm is set to sound after 300 hours on the hourmeter (when normal operation).

NOTICE

Be careful since the life of grease cartridge will be shortened if the greasing interval becomes shorter. Also, if the greasing interval becomes shorter, the amount of grease dripping from the tip of the working machine increases. It may make the machine and surrounding area dirty.

SETTING GREASING TIME IN COLD AREAS

In cold temperatures, the viscosity of the grease rises, so it is necessary to increase the greasing time.

For example, if the machine is used at temperatures below -20°C (-4°F), set the greasing time to 20 minutes (code No. 7). In addition, use lithium-based grease No. 0.

When changing the set value, please consult your Komatsu distributor.

OPERATION METHOD OF JOYSTICK STEERING SYSTEM

WARNING

- It is dangerous to turn the machine suddenly at high speed, or to turn on steep hills. Do not operate the steering in such conditions.
- When turning, the articulation stops at the position where the steering wheel is turned to, but if the joystick is held in the tilted position, the body will articulate fully.
- The feeling when operating the steering with the joystick is different from when operating with the steering wheel, so be extremely careful until you have become used to operating the joystick.
- When the joystick ON/OFF switch is at the ON position, if the directional lever is operated to F or R, the machine will travel in forward or reverse according to the operation of the directional lever, regardless of the position of the FNR switch on the head of the joystick lever. Priority is given to the operation of the directional lever, so be careful when operating.
- . When this is done, the central warning lamp lights up and the alarm buzzer sounds.
- . Set the directional lever and FNR switch on the head of the joystick to the N position.

Check the adjustment and operation before starting the engine. For details, see "CHECK BEFORE STARTING ENGINE, ADJUST (PAGE 3-90)".

1. Before starting the engine, check the operation of the joystick lever steering, check that the transmission directional lever is at N, and that the surrounding area is safe.

REMARK

Under the following conditions, a warning may be given when the engine is started.

- If the FNR switch on the joystick is at F or R, the joystick pilot lamp flashes, the central warning lamp lights up, and the alarm buzzer sounds.
In this condition, the engine will not start, so set the FNR switch to N.
- If the joystick is not at the N position, the joystick pilot lamp flashes, the central warning lamp lights up, and the alarm buzzer sounds.
In this condition, the engine will not start, so set the joystick to the N position.

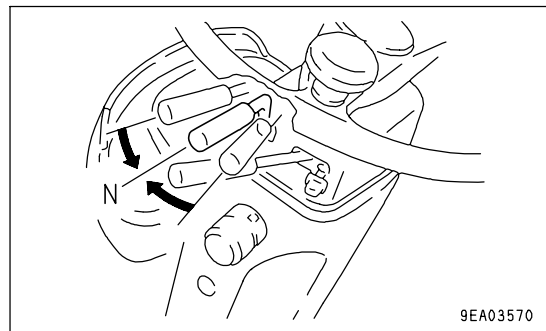

2. Press the (a) part of the joystick ON/OFF switch to turn it ON.

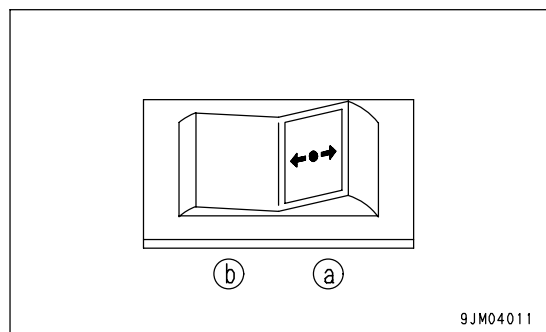

CLICK HERE TO **DOWNLOAD** THE COMPLETE MANUAL

- Thank you very much for reading the preview of the manual.
- You can download the complete manual from: www.heydownloads.com by clicking the link below



- Please note: If there is no response to CLICKING the link, please download this PDF first and then click on it.

CLICK HERE TO **DOWNLOAD** THE COMPLETE MANUAL