

# Operation & Maintenance Manual

# WA380-7

## WHEEL LOADER

**SERIAL NUMBERS**    **WA380-7 A64001** and up

**ENGINE**                **6D107E-2**

This material is proprietary to Komatsu America Corp. and is not to be reproduced, used, or disclosed except in accordance with written authorization from Komatsu America Corp.

It is our policy to improve our products whenever it is possible and practical to do so. We reserve the right to make changes or improvements at any time without incurring any obligation to install such changes on products sold previously.

Due to this continuous program of research and development, revisions may be made to this publication. It is recommended that customers contact their distributor for information on the latest revision.

Copyright 2013 Komatsu  
Printed in U.S.A.  
Komatsu America Corp.

August 2013

CLICK HERE TO **DOWNLOAD** THE COMPLETE MANUAL

- Thank you very much for reading the preview of the manual.
- You can download the complete manual from: [www.heydownloads.com](http://www.heydownloads.com) by clicking the link below



- Please note: If there is no response to CLICKING the link, please download this PDF first and then click on it.

CLICK HERE TO **DOWNLOAD** THE COMPLETE MANUAL

# TABLE OF CONTENTS

## INTRODUCTION

FOREWORD .....	0-2
SAFETY INFORMATION .....	0-3
APPROVED AND NON-APPROVED USES .....	0-4
Approved Functions .....	0-4
Non-Approved Functions .....	0-4
VISIBILITY STANDARD .....	0-5
Visibility in Immediate Area .....	0-5
12-M Radius Visibility .....	0-5
PRODUCT IDENTIFICATION .....	0-6
Directions Of Machine .....	0-6
Machine Serial Number .....	0-6
Engine Serial Number, EPA Regulations .....	0-7
Service Meter Location .....	0-7
SERIAL NUMBERS AND DEALER INFORMATION .....	0-8
Model: WA380-7 .....	0-8
TABLE OF CONTENTS .....	0-9

## SAFETY

SAFETY AND WARNING DECALS .....	1-2
Location of the Safety Decals .....	1-2
Safety Labels .....	1-4
GENERAL SAFETY RULES AND PRECAUTIONS .....	1-12
General Safety Rules .....	1-12
Unauthorized Modifications .....	1-12
General Safety at Job Site .....	1-13
Working on Loose Ground .....	1-13
Safety Features .....	1-13
Personal Protective Equipment .....	1-14
Fire and Explosion Prevention .....	1-14
Fire Caused by Fuel, Oil, Antifreeze, or Window Washer Fluid .....	1-14
Fire Caused by Accumulation of Flammable Material .....	1-15
Fire Caused by Electrical Wiring .....	1-15
Fire Caused by Hydraulic Lines .....	1-15
Fire Caused by Lighting Equipment .....	1-15
Action if Fire Occurs .....	1-16
Fire Extinguisher and First Aid Kit .....	1-16
Mounting and Dismounting .....	1-17
Inside Operator's Compartment .....	1-18
Precautions When Standing Up from Operator's Seat .....	1-19
Precautions Related to Roll Over Protective Structure (ROPS) .....	1-20
Unauthorized Modification .....	1-20
Emergency Escape from Operator's Cab .....	1-20
Leaving Operator's Compartment .....	1-21
Precautions When Cleaning Cab Glass .....	1-22

<b>RULES FOR OPERATION</b> .....	2-226
Permissible Water Depth .....	2-226
If Brake Does Not Stop Machine Movement .....	2-226
Travel On Slopes .....	2-227
Lower the Center of Gravity When Turning .....	2-227
Traveling Down Hill .....	2-227
If Engine Stops on Slope .....	2-227
Precautions for Travel .....	2-227
Precautions About Brake Performance .....	2-228
<b>REMOTE POSITIONER</b> .....	2-229
Remote Bucket Positioner Operation .....	2-229
Remote Boom Positioner Operation .....	2-230
Raise Remote Boom Positioner Operation .....	2-230
Reset Raise Remote Boom Positioner .....	2-230
Lower Remote Boom Positioner Operation .....	2-231
Reset Lower Remote Boom Positioner .....	2-232
<b>BUCKET LEVEL INDICATOR</b> .....	2-233
<b>PARKING THE MACHINE</b> .....	2-234
<b>CHECK AFTER FINISHING WORK</b> .....	2-236
Before Stopping Engine .....	2-236
After Stopping Engine .....	2-236
<b>LOCKING</b> .....	2-237
<b>HANDLING TIRES</b> .....	2-238
Precautions When Handling Tires .....	2-238
Tire Pressure .....	2-238
Precautions for Using Load-and-Carry Method .....	2-239
<b>TRANSPORTATION</b> .....	2-240
Transportation Procedure .....	2-240
Loading and Unloading with Trailer .....	2-240
Loading .....	2-240
Securing Machine .....	2-241
Securing Position .....	2-242
Unloading .....	2-243
Lifting Machine .....	2-244
<b>COLD WEATHER OPERATION</b> .....	2-246
Cold Weather Operation Information .....	2-246
Fuel and Lubricants .....	2-246
Coolant .....	2-246
Battery .....	2-246
After Daily Work Completion .....	2-247
After Cold Weather Season .....	2-247
<b>LONG-TERM STORAGE</b> .....	2-248
Before Storage .....	2-248
During Storage .....	2-248
After Storage .....	2-248
Starting Machine after Long-Term Storage .....	2-248
<b>TROUBLES AND ACTIONS</b> .....	2-249
Running Out of Fuel .....	2-249
Towing Machine .....	2-249

4. Cautions for working close to electric cables (09801-13001).

**Hazardous voltage hazard**

Serious injury or death can occur if machine or attachments are not kept safe distance away from electric lines.

	<b>Voltage</b>	<b>Safe Distance</b>
Low Voltage	100V - 200V	2 m (7 ft.)
	6,600V	2 m (7 ft.)
Special High Voltage	22,000V	3 m (10 ft.)
	66,000V	4 m (13 ft.)
	154,000V	5 m (16 ft.)
	187,000V	6 m (20 ft.)
	275,000V	7 m (23 ft.)
	500,000V	11 m (36 ft.)

## DANGER

**Hazardous voltage hazard.**  
 Serious injury or death can occur if machine or attachments are not kept safe distance away from electric lines

VOLTAGE		SAFE DISTANCE
LOW VOLTAGE	100V 200V	2 m
	6,600V	2 m
SPECIAL HIGH VOLTAGE	22,000V	3 m
	66,000V	4 m
	154,000V	5 m
	187,000V	6 m
	275,000V	7 m
	500,000V	11 m

09801-63001

5. There is a crush hazard between the articulating parts of the vehicle (09162-23000).

**Crush Hazard. Can cause severe injury or death.**

When machine is being operated, never place yourself in articulated area of machine.

## DANGER

**Crush Hazard. Can cause severe injury or death.**

When machine is being operated, never place yourself in articulated area of machine.

09162-23000

6. Caution for frame lock bar (09161-23000).

If safety bar is unlocked, machine can jackknife unexpectedly when it is being transported or hoisted.

Jackknifing can cause serious injury or death to bystanders.

- Always lock safety bar when machine is being transported or hoisted.
- If necessary, lock safety bar during servicing or maintenance.

## WARNING

If safety bar is unlocked, machine can jackknife unexpectedly when it is being transported or hoisted.

Jackknifing can cause serious injury or death to bystanders.

- Always lock safety bar when machine is being transported or hoisted.
- If necessary, lock safety bar during servicing or maintenance.

09161-23000

To prevent fire, always observe the following precautions:

- Do not smoke or use any flame near fuel or oil.
- Stop the engine before refueling.
- Do not leave the machine while adding fuel or oil.
- Tighten all fuel and oil caps securely.
- Always inspect around the entire fuel tank for leaks; clean or repair, if required.
- Inspect fuel system for leaks.
  - This includes fuel lines, filters, and injection system.
  - Clean or repair, if required.
- Do not spill fuel on overheated surfaces or on parts of the electrical system.
- Use an automotive-type washer fluid in the windshield washer system.
- Never use flammable fluids in the windshield washer system.
- Use well-ventilated areas for adding or storing oil and fuel.
- Keep oil and fuel in the determined place and do not allow unauthorized persons to enter.
- After adding fuel or oil, wipe up any spilled fuel or oil.
- When carrying out grinding or welding work on the chassis, move any flammable materials to a safe place before starting.
- When washing parts with oil, use a non-flammable oil. Diesel oil and gasoline may catch fire. Do not use them.
- Put greasy rags and other flammable materials into a safe container to maintain safety at the work place.
- Do not weld or use a cutting torch to cut any pipes or tubes that contain flammable liquids.



### Fire Caused by Accumulation of Flammable Material

- Remove any dry leaves, wood chips, pieces of paper, wood dust, or any other flammable materials accumulated or affixed around the engine, exhaust manifold, muffler, air cleaner, battery, or inside the undercovers.
- Be aware that operations such as logging, mulching, clearing, and landfill work may cause trash and debris to accumulate on the machine. Always remove accumulated trash and debris on a daily basis.
- Clean the machine after servicing the hydraulic system, engine, or fuel system.
- Operations near burn piles or other open burning may cause airborne sparks or glowing embers to cause a fire on the machine.

### Fire Caused by Electrical Wiring

Short circuits in the electrical system can cause a fire.

- Always keep electric wiring connections clean and securely tightened.
- Check the wiring every day for looseness or damage to the wire insulation.
  - Tighten any loose connectors or wiring clamps.
  - Repair or replace any damaged, pinched, or chaffed wiring.
- After-market radios or other electrically-operated equipment in the cab must be fused close to the power supply.

### Fire Caused by Hydraulic Lines

- Check that all the hose and tube clamps, guards, and cushions are securely fixed in position.
  - If they are loose, they may vibrate during operation and rub against other parts. This may damage the hoses and cause high-pressure oil to spurt out, leading to fire damage or serious injury.
- Check for oil leaks daily and repair them immediately.

### Fire Caused by Lighting Equipment

- When checking fuel, oil, battery electrolyte, or coolant, always use lighting with anti-explosion specifications.

## Precaution for Warning Tag

If there is a “DO NOT OPERATE” warning sign on the work equipment control levers, it means that someone is performing inspection and maintenance of the machine.

- Do not start the engine or touch the levers.
  - If this tag is ignored and the machine is operated, the serviceman may be caught in moving or rotating parts of the machine; this will cause serious personal injury or death.
  
- **ALWAYS** follow the warning sign and do not start the engine or operate any of the controls.

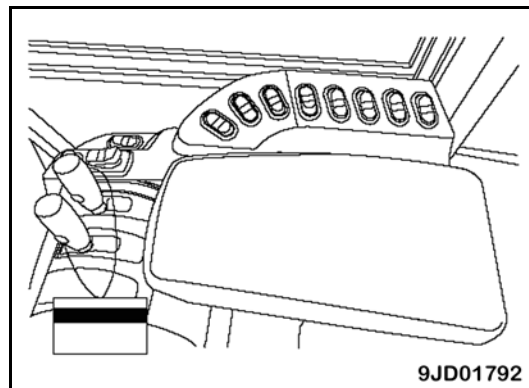

## Checks Before Starting Engine, Adjustments

Before starting the engine, perform the following checks and adjustments to confirm that there is no problem with operating the machine. If this step is not performed properly, there is a danger of serious personal injury to the operator or damage to the machine during operation.

- Clean all windows and mirrors on the machine, then adjust all mirrors to prevent any reduction in visibility.
- Securely fix frame lock lever (1) at the FREE position.
- Perform pre-operational checks of the machine.
  - See “Pre-Operational Checks” on page 1-24.
- Remove all dirt from the front lamps, work lamps, and combination lamps.
- Remove mud, dust, and debris accumulated around the movable parts of the accelerator and brake pedals.
- Check and make sure the pedals work properly.
- Walk around the machine and make sure there are no persons or obstacles above, below, or around the machine.
- Adjust the operator’s seat so it is easy to see to the front of the machine.
- Fasten your seat belt.
- Check for damage or wear to the seat belt or seat belt mounts.

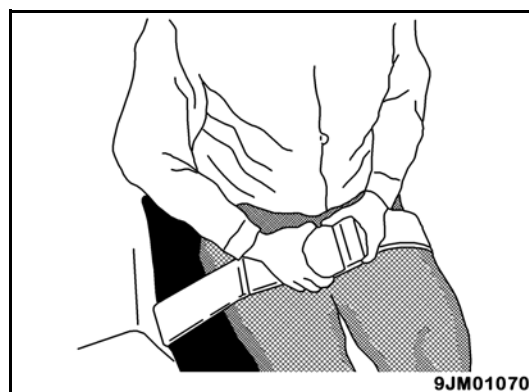
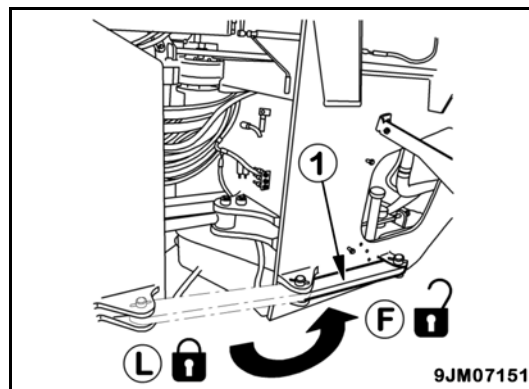

- Always travel straight up or straight down a slope.
  - Traveling at an angle on a slope may cause the machine to tip or possibly roll over.
- Do not turn on slopes or travel across slopes.
  - Always go down to a flat place to change the position of the machine then travel on to the slope again.
- Travel at low speed when traveling on grass, fallen leaves, or wet steel plates.
  - Even with slight slopes, there is a hazard that the machine may slip.
- When traveling downhill:
  - Travel slowly.
  - Always place the transmission in a low gear before starting to travel.
  - It is dangerous not to use the braking force of the engine. If necessary, use the braking force of the engine together with the brake pedal to control the travel speed.
  - Never shift gear or place the transmission at neutral.

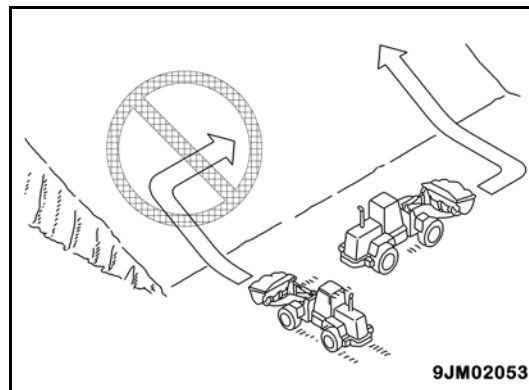

## Using the Brakes

- When the machine is traveling, do not rest your foot on the brake pedal.
  - If you travel with your foot resting on the pedal, the brake will always be applied; this will cause the brakes to overheat and fail.
- Do not depress the brake pedal repeatedly, if not necessary.
- When traveling downhill, use the braking force of the engine and always use the right brake pedal at the same time.

## Using Jumper Cables

When using jumper cables to start the machine, attach the positive (+) jumper **first** then the negative (-) jumper **last** to a remote location on the chassis, as shown in the following figure. For additional information, see “Start Engine with Booster Cables” on page 2-256.

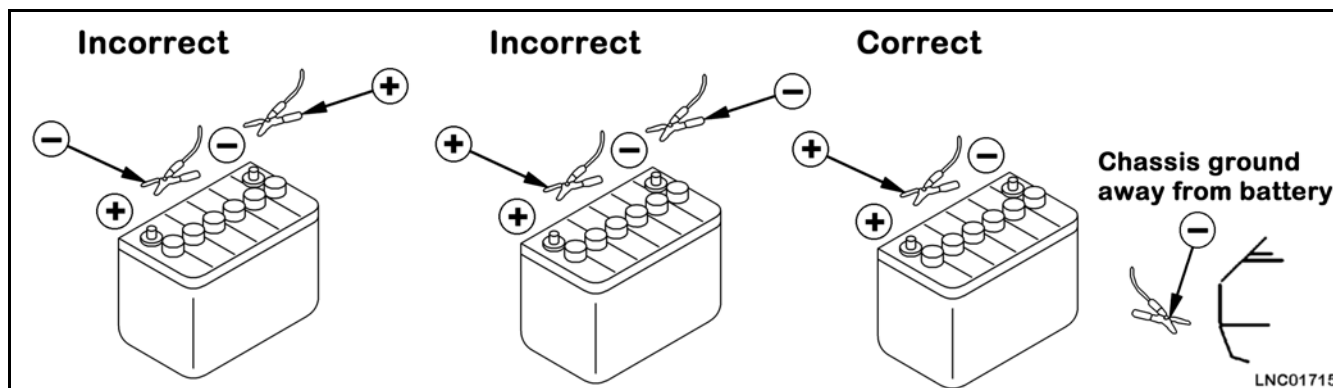

## Starting the Machine

### **WARNING**

- Never use a welder or a machine with a higher voltage system to jump-start the machine.
    - Using a higher voltage to jump-start a machine may damage the machine's electrical system or cause an unexpected explosion or fire.
  - Always jump-start a machine with one of equal voltage.
  - Never allow the machines to touch each other when jump-starting a machine.
- 
- Never try to start the machine by tampering or shorting the starter terminals.
    - Accidental movements of the machine could cause injury or even death.
  - Always start the machine while seated in the operator's cab using the starting switch.



**Details of Views A and B**

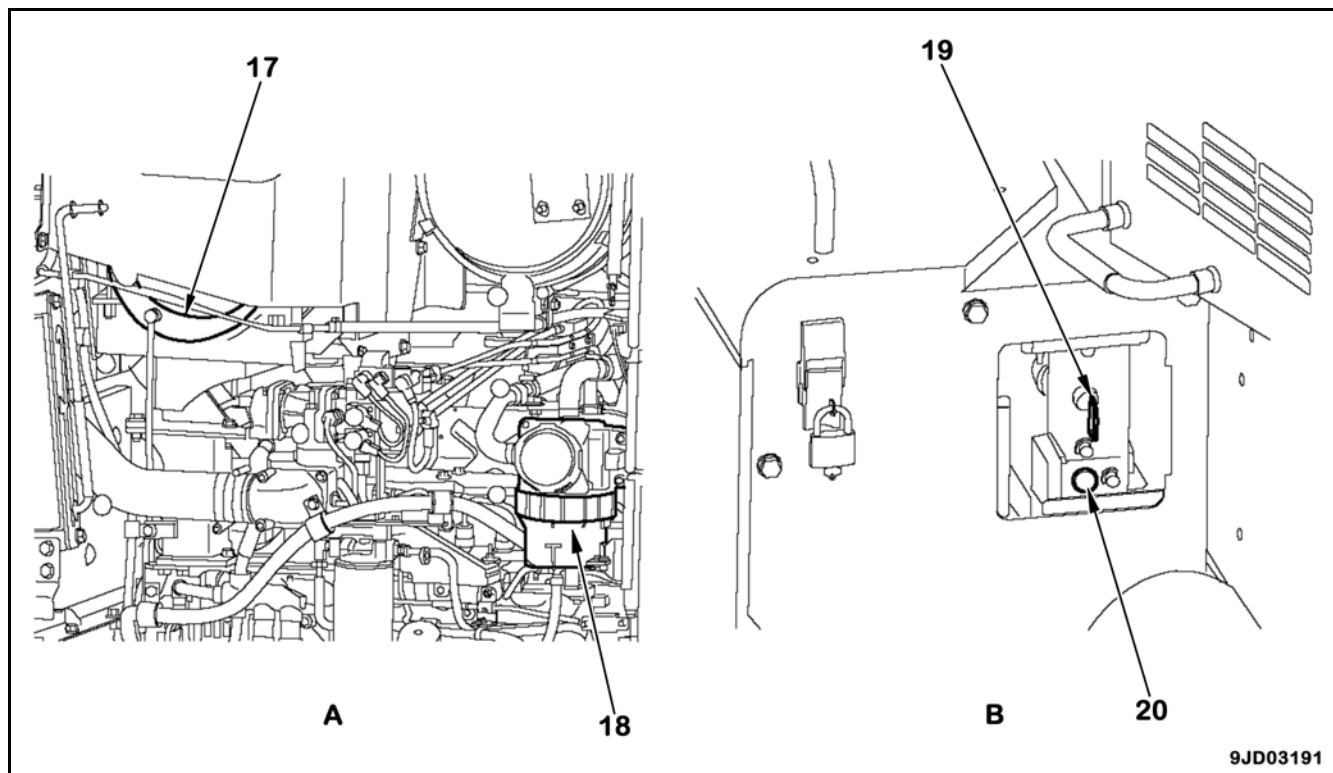

17. Komatsu Diesel Particulate Filter (hereafter KDPF)

19. Battery disconnect switch

18. Komatsu Closed Crankcase Ventilation (hereafter KCCV)

20. System operating lamp

## Stopping Engine When Situation is Normal

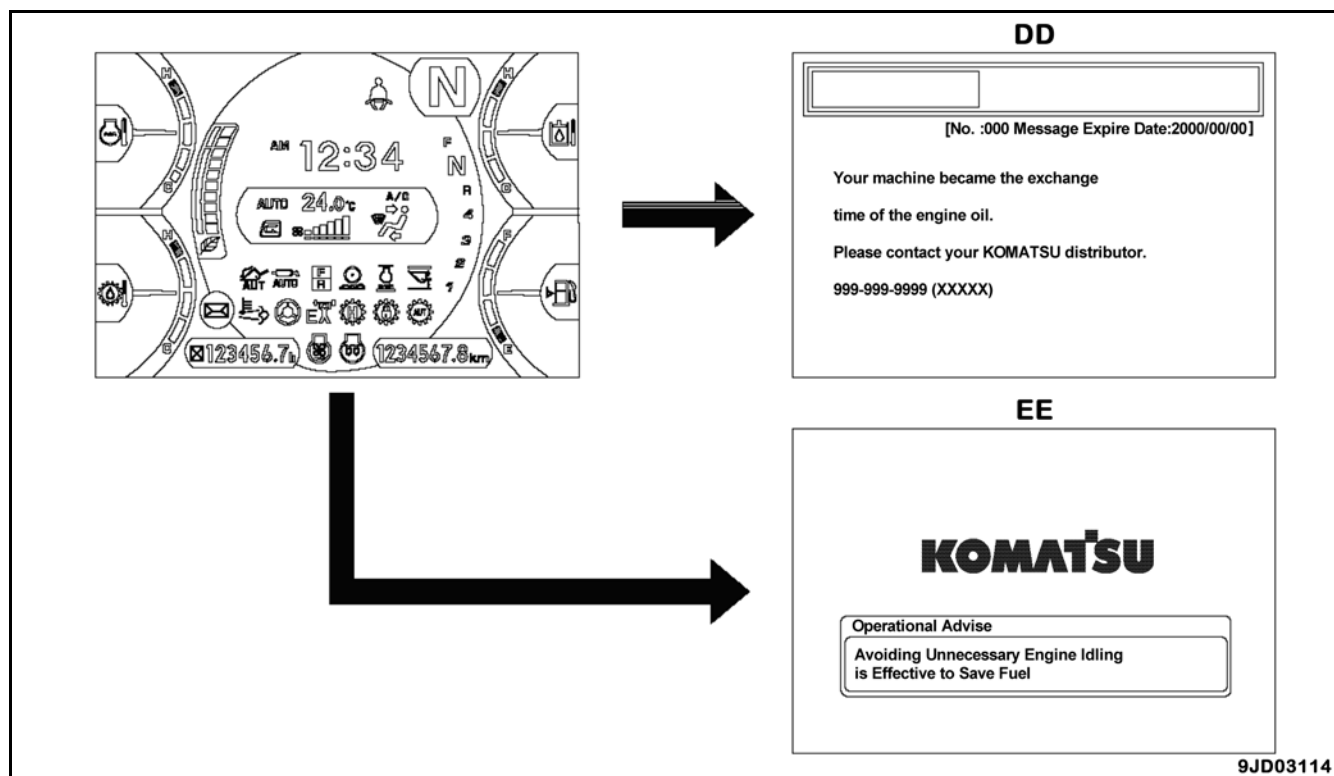

- ★ When starting switch is turned to the OFF position, the screen goes out. In the following case, the end screen is displayed for five seconds, and then screen goes out.

### End Screen with Message

If there is any message from your Komatsu distributor, it is displayed on end screen DD for five seconds, and then the screen goes out.

In this case, turn the starting switch to the ON position to re-check the message, and if it is the message requesting response, send back your reply.

For the method of display and reply for messages, see “Message Display” on page 2-88.

### End Screen with One-Point Advice

If there is any one-point advice, it is displayed on end screen EE for five seconds, and then the screen goes out.

For the one-point advice when ending, see “Switching Display/Non-Display of Guidance when Key is OFF” on page 2-62.

## Brake Oil Pressure Caution Lamp

This lamp (7) warns the operator that the brake oil pressure is below the specified value.

- When action level “L03” is displayed

If the brake oil pressure drops below the specified value while the engine is running, the lamp lights up red. The centralized warning lamp lights up simultaneously and alarm buzzer sounds intermittently.

Stop the operation, move the machine to a safe place, stop the engine, then have your Komatsu distributor perform the inspection and maintenance.

- Action level is not displayed and lamp lights up red

If the brake oil pressure is below the specified value while the engine is stopped, the lamp lights up red.

When the engine is started, the lamp lights up red until the brake oil pressure rises above the specified value. The centralized warning lamp lights up simultaneously and alarm buzzer sounds intermittently.

Wait until the lamp goes out, and then start the machine.

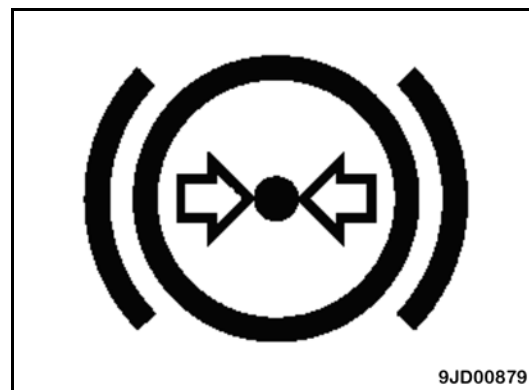

9JD00879

## Seat Belt Caution Lamp

This lamp (8) lights up if the seat belt is not fastened.

There is a danger when traveling, so always fasten your seat belt.

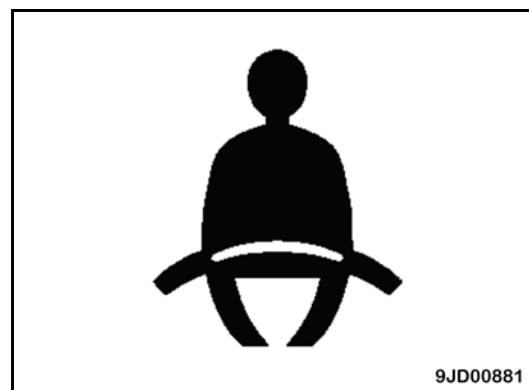

9JD00881

**MEMORANDUM**

## ECO Guidance

This guidance (24) is displayed during the operation that lowers the fuel efficiency, and support energy saving operation for reducing the fuel consumption.

The details of the guidance are as follows:

### Excessive Idling Stop Guidance

If the engine continues running idle for more than five minutes, the excessive idling message is displayed on the monitor.

When waiting for work or taking a short break, stop the engine to reduce unnecessary fuel consumption.

- When the accelerator pedal is depressed or the machine starts traveling or the work equipment is operated, the excessive engine idling message goes out.

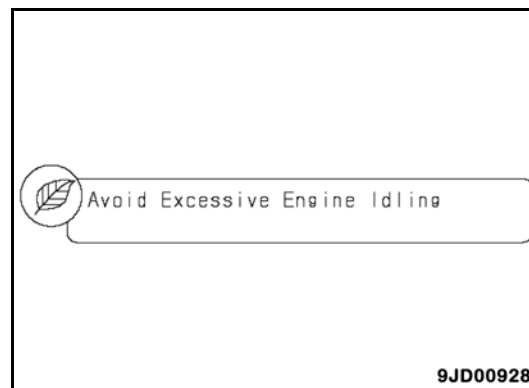

### Guidance to Avoid Hydraulic Relief

If the hydraulic equipment is relieved for more than eight seconds during operation, the notification of hydraulic relief limit is displayed on the monitor.

The hydraulic equipment is relieved when an attempt is made to lengthen each cylinder further over the maximum (for example, to move bucket control lever to TILT while the bucket is fully tilted) or reduce it further over the minimum.

Stop unnecessary relief.

- The notification of hydraulic relief limit goes out automatically after 10 seconds.

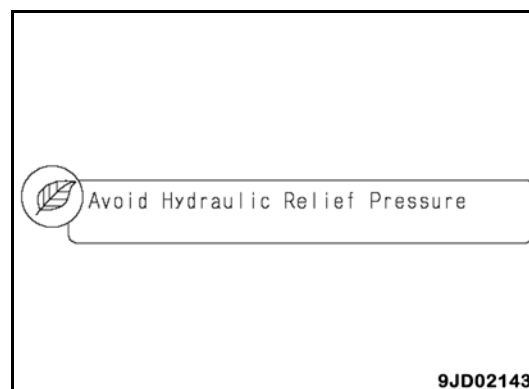

### Brake Dragging Prevention Guidance

If the accelerator pedal is depressed for more than three seconds while applying the brake during traveling, the brake dragging limit message is displayed on the monitor.

If the accelerator is operated while the brake is used, fuel consumption is increased.

- The brake dragging limit message goes out automatically after 10 seconds.

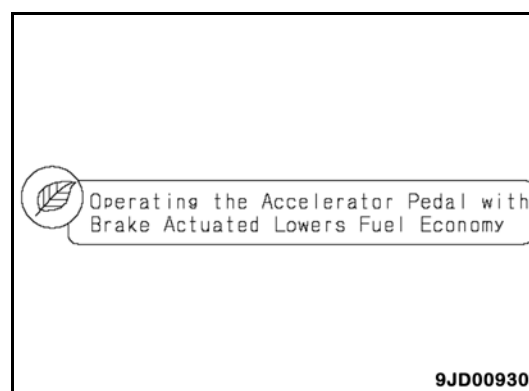

## User Menu

When menu switch (1) is pressed on the standard screen while the machine is stopped, the user menu screen is displayed to enable you to configure and confirm machine settings.

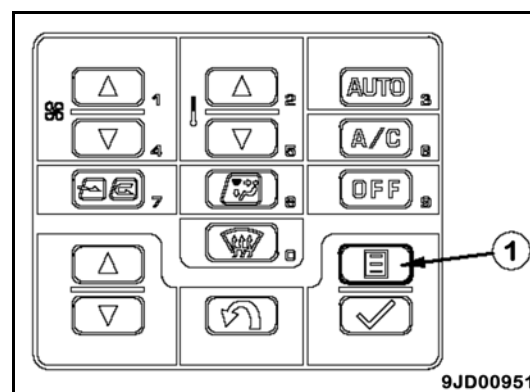

The user menu consists of the following kinds. The menu screen can be changed by pressing the menu switch (1).

- (a): ECO guidance
- (b): Machine setting/Information
- (c): KDPF regeneration
- (d): Maintenance
- (e): Monitor setting
- (f): Message display

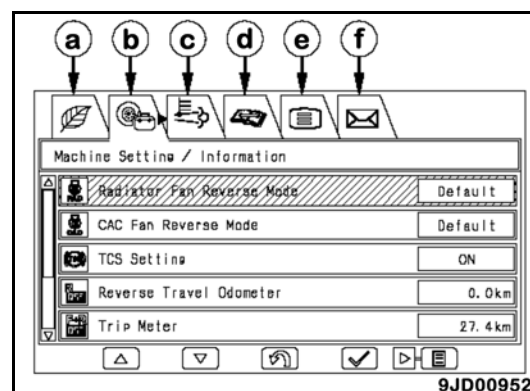

These menus (a) to (f) are for setting and confirming the following items:

- a: ECO guidance
  - Check of operating record
  - Check of ECO guidance record
  - Check and reset of fuel consumption record
  - Configurations
- b: Machine setting/Information
  - Setting for manual fan reverse mode
  - Setting for automatic fan reverse mode
  - Setting for semi auto-digging setting
  - Setting for bucket flat level select
  - Auto Kick Down Setting
  - Display and reset of trip meter
  - Setting for auto idle stop
- c: KDPF regeneration
  - Setting for regeneration disable
  - Operation of manual stationary regeneration
- d: Maintenance
  - Check and reset of various maintenance remaining times
- e: Monitor setting
  - Rear View Monitor Setting
  - Meter Select
  - Screen Adjustment
  - Clock Adjustment
  - Language selection
- f: Message display
  - Check of message contents and reply to message

## Switching Display/Non-Display of Guidance when Key is OFF

Display/non-display of the one-point advice indicated on the end screen when the key is turned to the OFF position can be switched.

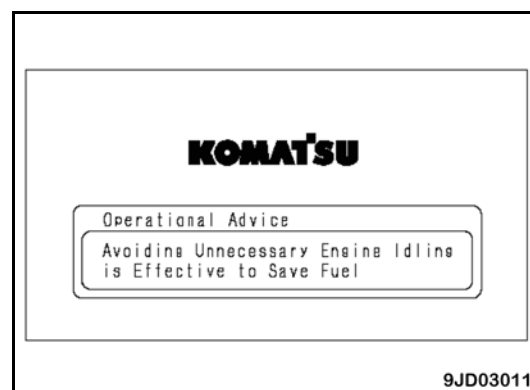

1. Select display ECO Guidance at key off (1) from the display setting menu, then press enter switch.

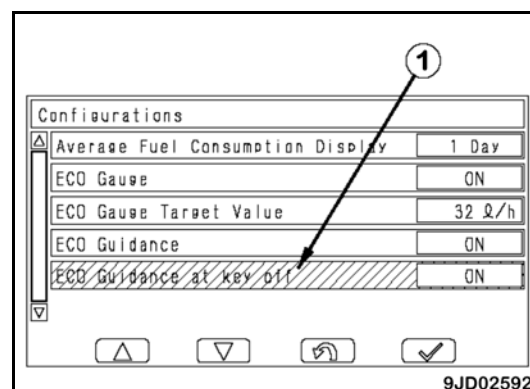

2. Select ON or OFF, then press the enter switch.  
 ON: Displays the one-point advice on the end screen.  
 OFF: Does not display the one-point advice on the end screen.  
 To cancel setting, press the return switch.  
 Initially, ON is selected.

### Remark

*In the one-point advice section indicated on the end screen, the advice to the ECO guidance that was displayed most frequently after the key is turned to the ON position is indicated. Accordingly, the one-point advice indicated on the end screen may be different from the one-point advice indicated on "ECO Guidance Record" on page 2-55.*

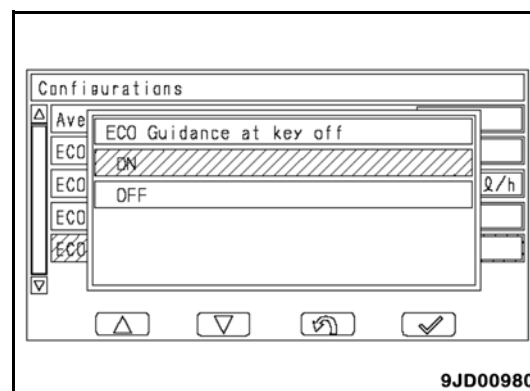

### Bucket Flat Level Initialize

You can return the bucket flat level after adjustment to the default value.

1. Select a type of bucket you want to initialize from the "Bucket Flat Level Select" screen, then press the menu switch.

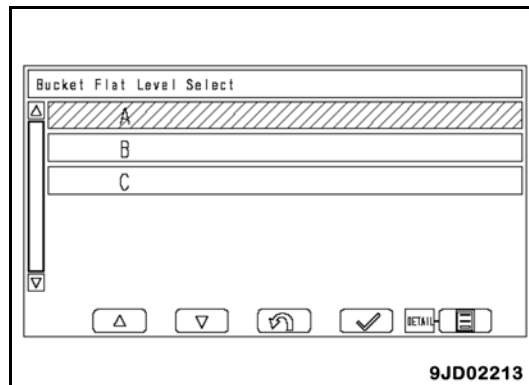

2. Select the "Bucket Flat Level Initialize," then press the enter switch.

The initialization starts.

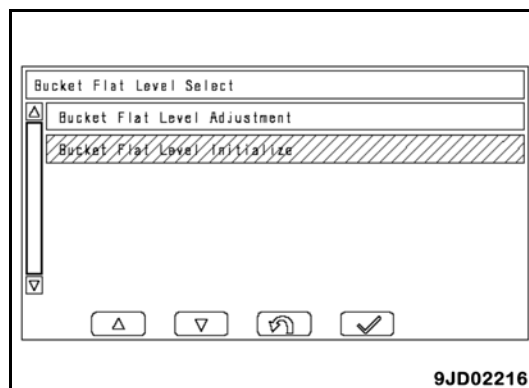

3. Press the enter switch on the confirmation screen to return the flat level of the selected bucket to the default.

When the initialization is not necessary, press the return switch.

4. The screen returns to "Bucket Flat Level Select" screen.

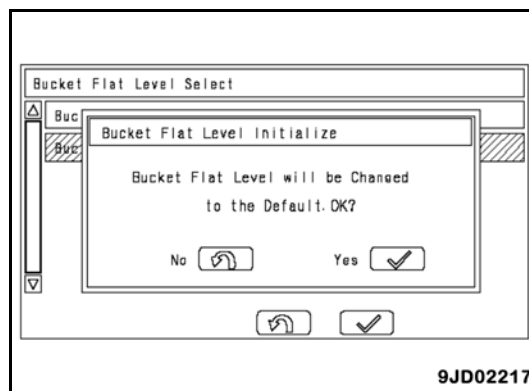

## Screen Adjustment

This function is used for the adjustment of brightness of the machine monitor.

1. Select Screen Adjustment on the Monitor Setting screen, then press the enter switch.

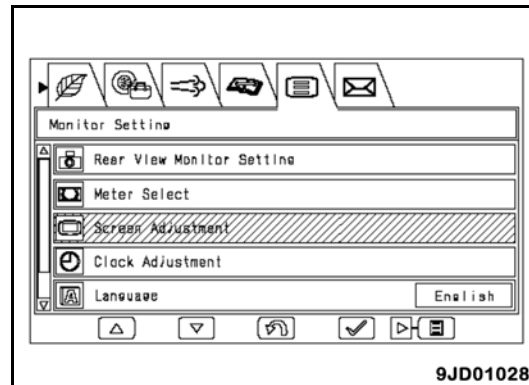

2. Adjust the brightness by using the switch panel.
 

The brightness can be adjusted individually in the day and night modes.

Menu switch: Sets brightness to the initial state.

UP switch: Increases the brightness. (Moves the indicator to the right by one division.)

DOWN switch: Decreases the brightness. (Moves the indicator to the left by one division.)

Return switch: Cancels the change and returns to the Monitor Setting menu.

Enter switch: Accepts the change and returns to the Monitor Setting menu.

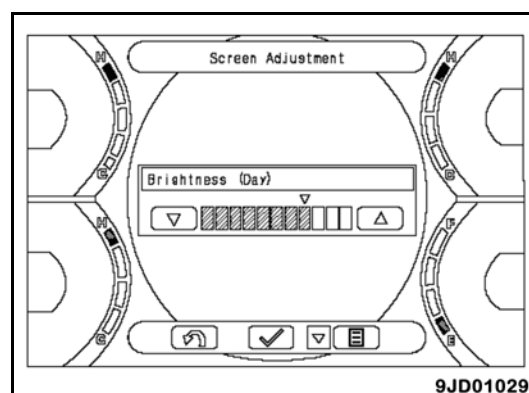

### Remark

- When the screen is adjusted while the lamp switch is turned OFF, the brightness in the day mode can be adjusted.
- Turn the lamp switch ON, then adjust the screen when the monitor brightness selector switch is set to the day mode, the brightness in the day mode can be adjusted.
- Turn the lamp switch ON, then adjust the screen when the monitor brightness selector switch is set to the night mode, the brightness in the night mode can be adjusted.
- The brightness of night illumination for the switch panel and operation switches is adjusted synchronously with the brightness of the machine monitor.

- |                                            |                                                                         |
|--------------------------------------------|-------------------------------------------------------------------------|
| 1. Starting switch                         | 15. Cigarette lighter                                                   |
| 2. Power mode selector switch              | 16. Room lamp switch                                                    |
| 3. Transmission shift mode selector switch | 17. Heated wire rear glass switch                                       |
| 4. Transmission cut-off switch             | 18. E.C.S.S. switch                                                     |
| 4. Transmission cut-off set witch          | 19. Emergency steering switch (if equipped)                             |
| 5. Lamp switch                             | 20. Torque converter lockup switch                                      |
| 5. Turn signal lever                       | 21. Beacon lamp switch (if equipped)                                    |
| 5. Dimmer switch                           | 22. R.H. switch panel directional selection enable switch (if equipped) |
| 6. Horn switch                             | 23. Directional selector switch (if equipped)                           |
| 7. Hazard lamp switch                      | 24. Remote positioner switch                                            |
| 8. Parking brake switch                    | 25. 2-stage low idle switch                                             |
| 9. Front working lamp switch               | 26. Engine shutdown secondary switch                                    |
| 10. Rear working lamp switch               | 27. Rear view monitor brightness adjustment switch                      |
| 11. Kick-down switch                       | 28. Monitor brightness selector switch                                  |
| 12. Hold switch                            | 29. Quick Coupler Attachment Switch (if equipped)                       |
| 13. Front wiper switch                     |                                                                         |
| 14. Rear wiper switch                      |                                                                         |

## Starting Switch

This switch (1) is used to start or stop the engine.

### A: OFF position

At this position, the starting switch key can be inserted and removed.

When the switch is turned to this position, all the electric circuits are shut off and the engine stops. And, the parking brake applies automatically.

### B: ON position

Electric current flows through the charging and lamp circuits. Keep the starting switch key at the ON position while the engine is running.

When the ambient temperature is low during engine startup, the engine preheating pilot lamp lights up and engine preheating starts automatically.

This preheating time depends on the ambient temperature during engine startup.

When the engine preheating pilot lamp lights up, wait for a while.

When it goes out, then turn the starting key to the START position.

### C: START position

This is the position to start the engine. Hold the key at this position while cranking the engine. Release your fingers off the key immediately after the engine has been started. The key will return to ON position (B).

### D: Manual preheat position

In the cold weather, the engine preheating time can be increased longer than the automatic preheating time. To make it, rotate the starting switch key to this position.

When you release your fingers off the key, it returns to position (A). Start up the engine immediately by rotating the key to position (C).

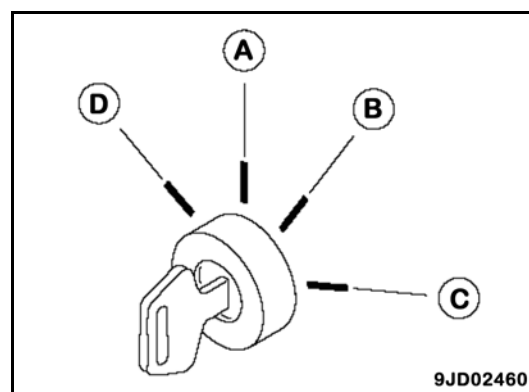

## E.C.S.S. Switch

# WARNING

- Note that the work equipment starts moving the moment the E.C.S.S. switch is turned ON while the machine is traveling or the work equipment is being raised.
- When the machine is operated with the E.C.S.S. switch turned ON, note that the work equipment may start moving at the moment the E.C.S.S. operates.
- Be sure not to turn the E.C.S.S. switch to ON position as long as the inspection or maintenance is continued. The work equipment will move and it is dangerous.

## NOTICE

- **Before operating the E.C.S.S. switch, be sure to stop the machine and lower the work equipment to the ground.**
- **When performing inspection or maintenance, lower the work equipment to the ground first, turn the E.C.S.S. switch to the OFF position, then start the work.**
- **Keep the E.C.S.S. switch turned OFF during leveling work.**

This switch (18) is used to turn the E.C.S.S. ON or OFF.

Position (a): ON

The pilot lamp lights up and the E.C.S.S. operates.

Position (b): OFF

The E.C.S.S. does not operate.

### Remark

- *The E.C.S.S. absorbs the machine vibration during travel with the hydraulic spring effect of the accumulator to attain smooth high speed travel.*
- *The E.C.S.S. does not operate while the machine travels in the 1st gear speed.*
- *The E.C.S.S. does not operate if the boom angle is 25° or more above the horizontal level.*
- *If the travel speed exceeds 5 km/h {3.1 MPH} while the gear speed is 2nd to 4th, the E.C.S.S. operates automatically.*
- *If the travel speed decreases below 4 km/h {2.5 MPH}, the E.C.S.S. stops operation automatically.*
- *When the bucket is empty and the work equipment is positioned at a low height, you may feel the poor damper effect. This is not an abnormality.*

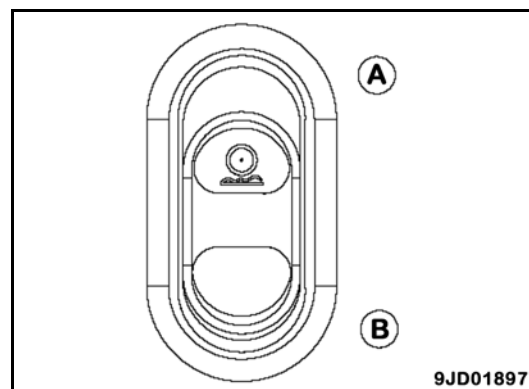

## Emergency Steering Switch (If Equipped)

This switch (19) is used to manually operate the emergency steering.

Even when the engine is stopped, pressing this switch allows operating the steering.

Position (a): ON

The pilot lamps inside the switch and the emergency steering pilot lamp on the machine monitor light up and it becomes possible to operate the steering.

If you release your hand from the switch, it automatically returns to its original position.

Do not activate the emergency steering except in emergency or checking the function.

The emergency steering is continuously operable up to 60 seconds.

When using the emergency steering, maintain the travel speed at 5 km/h (3.1 mph) or below.

For details, see “Emergency Steering (If Equipped)” on page 2-203.

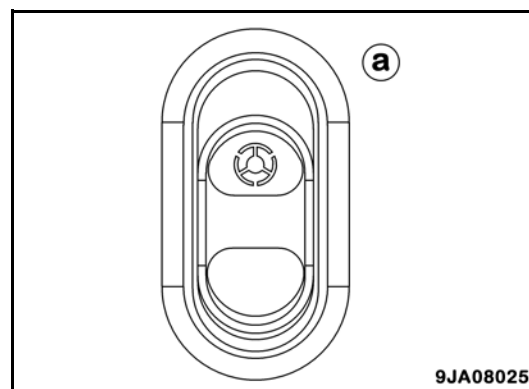

## Brake Pedal

# ⚠ WARNING

- While traveling downhill, use the engine brake with the transmission cut-off function being shut off. The brake pedals, one each of which is provided on both sides with the steering post located in the middle, offer the same function.
- Do not depress the brake pedal repeatedly if not necessary. Excessive use of the brake heats it up, degrading its function and may result in serious personal injuries.
- Do not rest your foot on the brake pedal unless it is required.

### NOTICE

Frequent braking increases the axle oil temperature. As a result, the alarm buzzer may sound and the warning lamp may light up for protection of the brake discs. Observe the following ways of operation to prevent the increase of the axle oil temperature.

- Try to reduce the speed and avoid sudden braking. Before depressing the brake pedal, shift down the gear speed manually with the gear speed switch.
- Try to apply the brake on and off rather than continuously.
- Try gradual acceleration and braking without resorting to sudden acceleration and braking.
- When traveling downhill, use a low gear speed so that the engine braking works well.
- During loading work on a level ground, use of the cut-off brake is recommended since it cuts off the power transmission.

This pedal (6) is used to operate the wheel brakes.

### R.H. Brake Pedal

This pedal is used to operate the wheel brake.  
Use it for the normal braking.

### L.H. Brake Pedal

This pedal is used to operate the wheel brake.  
When the transmission cut-off switch is set to the ON position, the wheel brake is applied and the transmission is set to neutral.  
When the transmission cut-off switch is set to the OFF position, this brake pedal functions in the same way as the R.H. brake pedal.

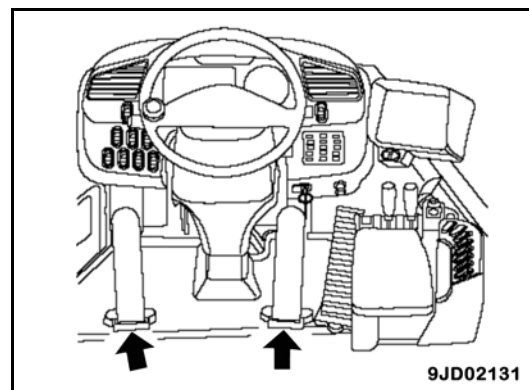

### Remark

*When you need to operate the work equipment while decelerating or stopping the machine by use of the brake and accelerator pedal, turn the transmission cut-off switch to the ON position and use the L.H. brake pedal. This can suppress to heat the braking system.*

2. Hold door knob (1) and pull it toward the rear of the machine.

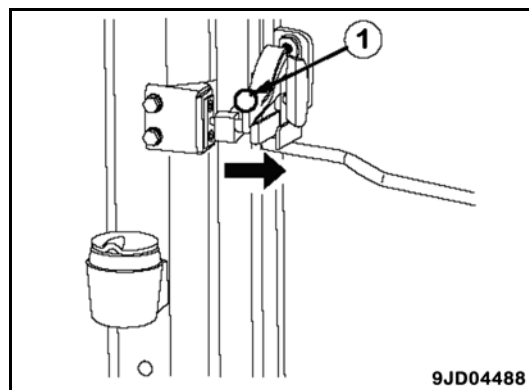

3. Remove the guide rail of the door knob from the guide pin fixed to the cab and unlock the right side door.

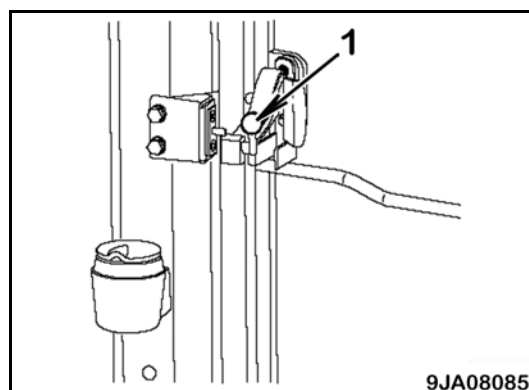

4. Open the right side door wide and go out.

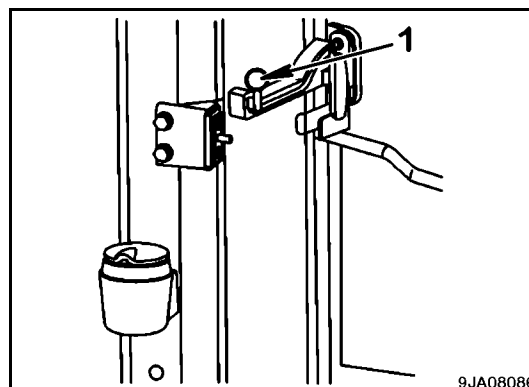

To lock door knob again, hold door knob (1) and pull it toward the rear of the machine. Match the guide rail of the door knob with the guide pin on the guide cab side and push in the door knob forward. Check that the guide pin is inserted into the guide rail securely, and push in and fix door knob (1) to the lock position.

### NOTICE

If the door is closed without holding door knob (1), the plastic part of the door knob hits against guide pin (2) on the cab side and may be broken. Always close the door while holding door knob (1).

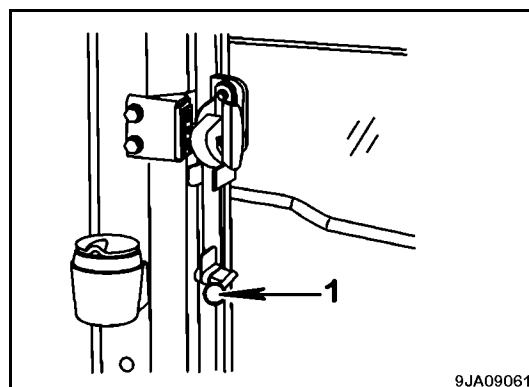

### Auto Switch

Use this switch (2) for automatic selection of the air flow and vents according to the set temperature.

This switch is also used as the main switch of the air conditioner.

- When the AUTO switch is pressed, "AUTO" on the display monitor lights up to indicate that the air conditioner is in the automatic mode.

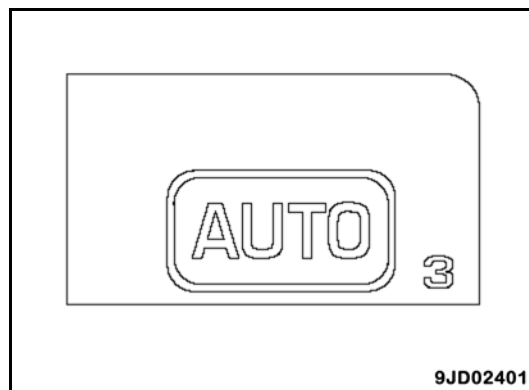

- When switching from automatic operation to manual operation, it is possible to use the switches to select the air flow and vents. At this time, "AUTO" on the display monitor goes out.
- When the window is fogged up because of the low temperature, turn the defroster switch to ON and defrost the window.

**Remark**

*Do not leave the door open for a long time (three minutes or longer) while the air conditioner is working. Automatic air conditioner is automatically controlled according to the environment. If the environment changes suddenly by leaving the cab door open for a long time, the air conditioner control may change temporarily, however, this is not a failure. Even if the control changes, it returns automatically to AUTO control according to the environment after a certain period of time elapses.*

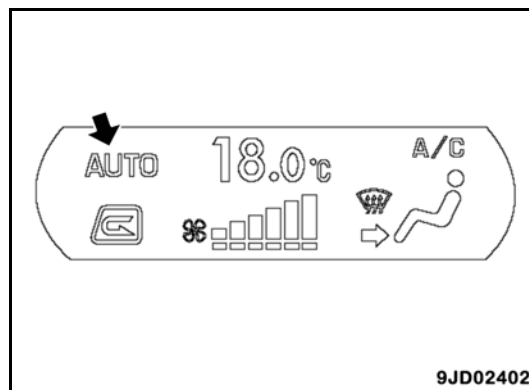

### Air Conditioner Switch

Use this switch (3) to start and stop the cooling or dry heating function.

- When the air conditioner switch is pressed while the main power switch is turned ON, the air conditioner is turned ON and the air conditioner operation symbol is indicated on the display monitor.

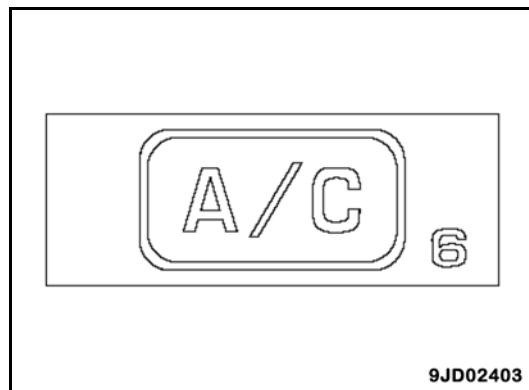

- If the switch is pressed again, it is turned OFF and the operation symbol on the display monitor goes out.

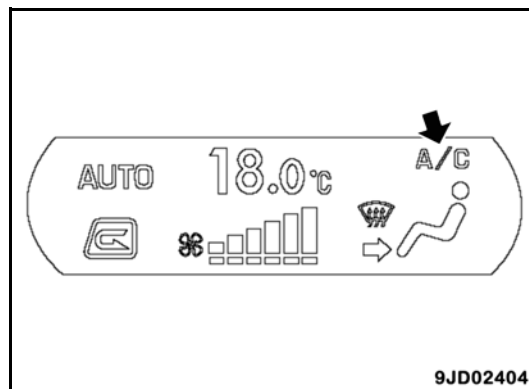

CLICK HERE TO **DOWNLOAD** THE COMPLETE MANUAL

- Thank you very much for reading the preview of the manual.
- You can download the complete manual from: [www.heydownloads.com](http://www.heydownloads.com) by clicking the link below



- Please note: If there is no response to CLICKING the link, please download this PDF first and then click on it.

CLICK HERE TO **DOWNLOAD** THE COMPLETE MANUAL

## Demist Operation

Condensation adhered to the inside of the window glass can be removed by the demist operation.

1. Press defroster switch (8) to set the vent in the defroster mode.

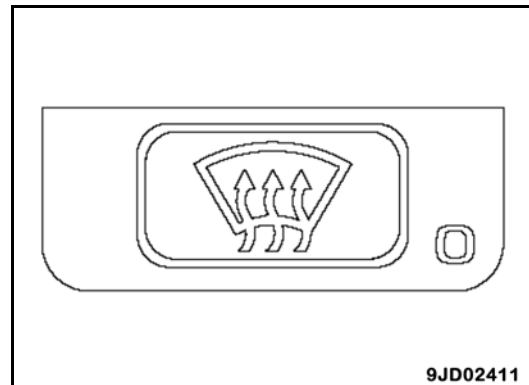

2. Press air conditioner switch (3) and perform the cooling or dry heating operation.

To remove the condensation quickly, press the fan switch to set the air flow to "Hi."

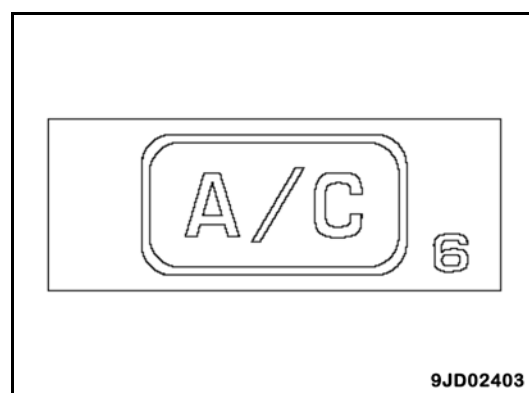

### Remark

*Do not decrease the set temperature too much during the demist operation. If the cold air blows against the front windshield glass, the outside of the glass become dim and that may lower the visibility.*

7. This screen is displayed during the manual stationary regeneration. It may take more than 30 minutes to complete the manual stationary regeneration. Do not touch the screen switches or operate the accelerator pedal until the regeneration is complete and the standard screen appears again.

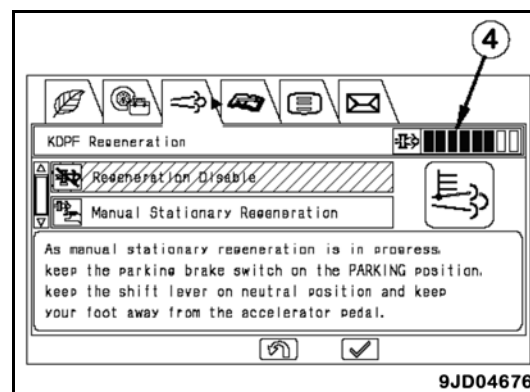

#### Remark

- The progress of the manual stationary regeneration performed when soot is accumulated is checked by the number of lighting lamps of soot accumulation level (4). The manual stationary regeneration starts at with the soot accumulation level at "4" or higher and finishes when all the level lamps go out.
- The manual stationary regeneration for protection of the system during cold season may start with the soot accumulation level at "0" to "3." In this case, the soot accumulation level may not decrease, but this is not a failure. The progress is not displayed on the monitor during this regeneration. It is completed in about 10 minutes.
- If the accelerator pedal or directional lever is operated, or the parking brake is released during the manual stationary regeneration, the regeneration is stopped automatically. Release your foot from the accelerator pedal, set the directional lever to neutral (N) position, make sure RPM setting is disabled and apply the parking brake. Then repeat the procedure from Step 6.
- When the machine needs to be moved during the manual stationary regeneration, stop the regeneration temporarily and move the machine, referring to the KDPF regeneration disable and cancel of regeneration disable procedures described below. When restarting the manual stationary regeneration, secure the safety of the machine and around it, then cancel the regeneration disable.

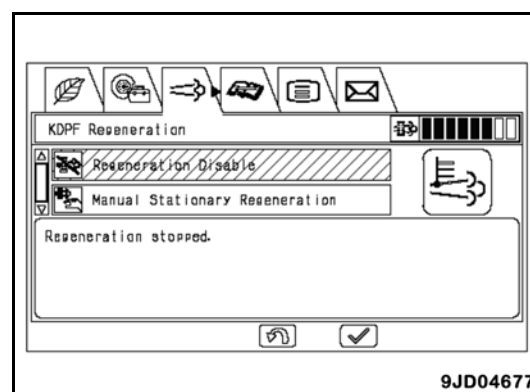

8. After the manual stationary regeneration is completed, the screen automatically returns to the standard screen.

## KDPF Regeneration Stop Procedure

If the automatic active regeneration that increases the exhaust temperature must not be performed as in the case where there is combustible material around the machine, the automatic KDPF regeneration can be disabled. Also, the regeneration in progress can be stopped.

#### NOTICE

Even if the regeneration is disabled, the KDPF soot accumulation caution lamp (1) lights up if soot is accumulated and the manual stationary regeneration is required. If the KDPF soot accumulation monitor lights up, move the machine to a safe place and carry out manual stationary regeneration.

If the operation is continued without carrying out the manual stationary regeneration, it may cause the failure of the KDPF or the engine.

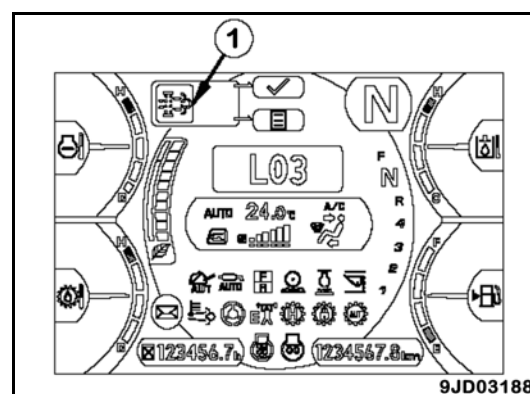

## Check Coolant Level, Add Coolant

# ⚠ WARNING

- Do not open the radiator cap unless necessary. When checking the coolant level, check the sub-tank when the engine is cold.
- Immediately after the engine is stopped, the coolant is at high temperature. And the pressure is still accumulated in the radiator. If the cap is removed in this condition, there is a hazard of burns. Accordingly, wait until the coolant temperature drops, then slowly turn the cap to release the pressure.
- When refilling with coolant, always support your body securely by using the steps and handrails provided.

1. Open platform cover (1) on the right side of the machine.
2. Check if the coolant in sub-tank is between the FULL and LOW marks. If the coolant level is low, add coolant to the FULL level through the filler port of sub-tank.
3. After adding coolant, tighten the cap securely.
4. If the sub-tank becomes empty, there is probably a coolant leak. After checking, repair any abnormality immediately. If an abnormality is not found, check the coolant level in the radiator. If it is low, add coolant of the density specified in the coolant density table in "Clean Inside of Cooling System" on page 3-26 to the radiator, then add coolant to the sub-tank. If more coolant than the usual level is added, check for leakage of coolant. Check that there is no abnormality such as oil in the coolant.

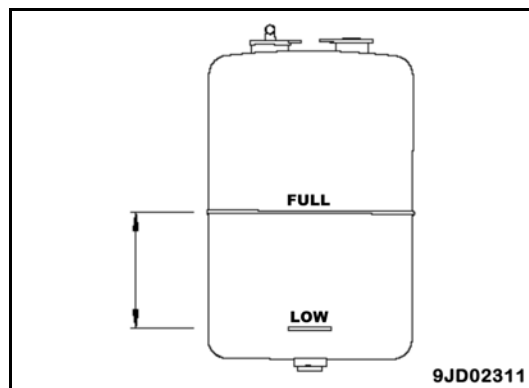
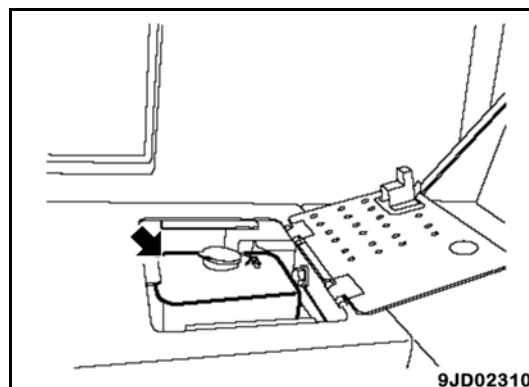
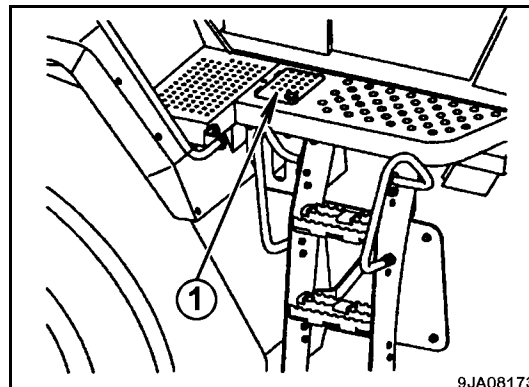

2. When you want to decrease the shock to the seat, adjust the knob to 2nd stage position (d) or 1st stage position (c). (The damper becomes softer.)

(N) Seat heater (If equipped)

When switch (10) is operated in the (x) direction, the heater inside the seat cushion is activated. When it is operated in the (y) direction, the heater is turned off. Turn off the switch when the temperature of cushion becomes suitable.

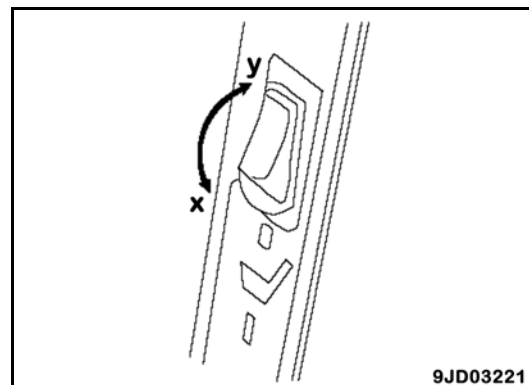

9JD03221

## ! WARNING

- Using the heater for a long time may cause low temperature burn (blister, etc.).
- Do not put heavy luggage on the cushion. Do not stick the cushion with needles, nails, etc.
- Do not put blanket, cushion, or other heat-retaining material on the seat cushion. Doing so may cause overheat.
- If water or juice, etc. spills on the seat cushion, wipe it off with soft cloth, etc., and dry out the seat cushion before using it.

**Remark**

*The heater has no timer function and is not turned off automatically.  
Be sure to turn the switch off after using the heater.*

## Head Rest

### Removal

When the head rest is not necessary, remove it according to the following procedure.

1. Pull up the head rest until it stops.
2. Pull up the head rest with a little force, and it will come out.

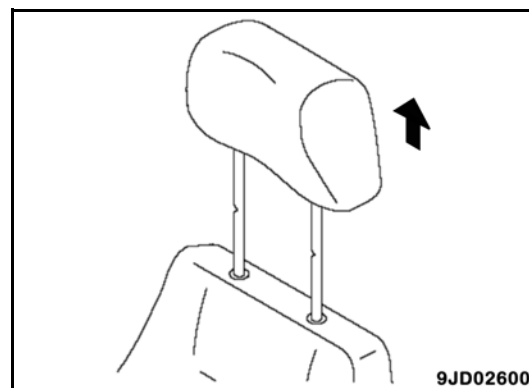

9JD02600

### Installation

1. Insert the headrest into the holes of the back seat and press down.

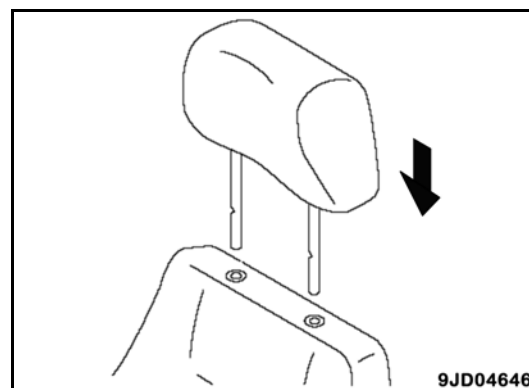

9JD04646

2. If preheating pilot lamp (2) does not light up, or it lights up and then goes out to inform that the engine preheating has been completed, turn the key in starting switch (1) to START position (C).
3. The starting motor keeps running to start the engine.  
Keep the key in starting switch (1) at START position (C) to keep running the starting motor until the engine starts.

**Remark**

*When the temperature low, fuel is not supplied to the engine for three seconds to ensure lubrication of the engine and to improve the durability after the key in starting switch (1) is turned to START position (C), so the engine does not start during this time.*

*Accordingly, keep the key in starting switch (1) at START position (C) to keep running the starting motor until the engine starts.*

4. When the engine starts, release the key in starting switch (1).  
The key will return automatically to ON position (B).

After the engine is started, white smoke may come out of the exhaust pipe. It is fine water particles which are produced from moisture or water vapor and which seem white, thus it does not indicate a problem.

The smell of the exhaust gas is different from that of the conventional diesel machine because of the exhaust gas filtering function.

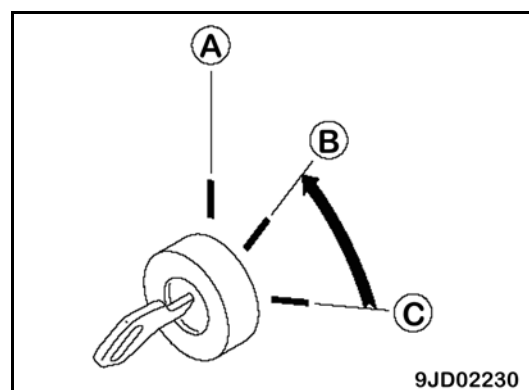
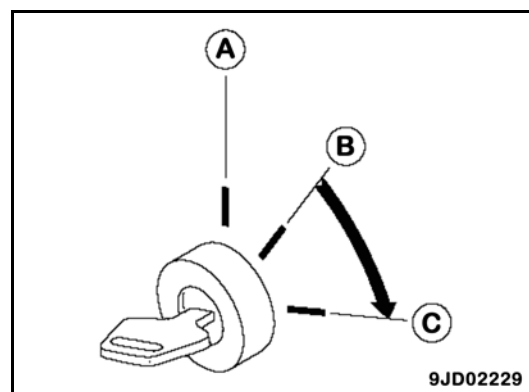

- Set directional lever (7) to the desired position.

Position (F): Forward

Position (N): Neutral

Position (R): Reverse

- Check that the back-up alarm sounds when the directional lever is set to R. If the back-up alarm does not sound, have your Komatsu distributor perform repairs.

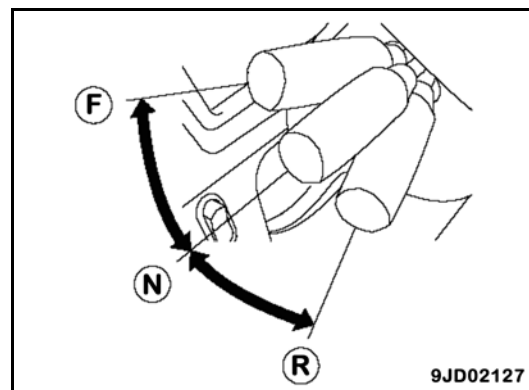

### Remark

Switch (8) also serves to switch the travel direction among FORWARD, NEUTRAL, and REVERSE.

Position (F): Forward

Position (N): Neutral

Position (R): Reverse

When selecting the FORWARD, NEUTRAL or REVERSE with this switch (8), set directional lever (7) to the NEUTRAL position and directional selector enable switch on R.H. switch panel (12) to the ON position.

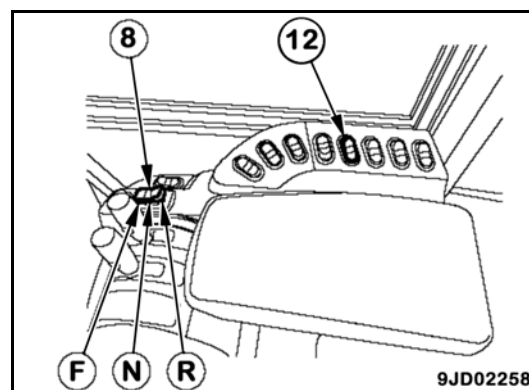

- Release R.H. brake pedal (5), then depress accelerator pedal (9) to start the machine.

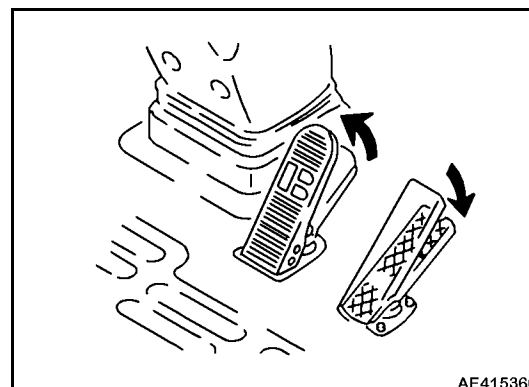

## Steering Machine

### **WARNING**

- Avoid steering during high-speed travel or steering on a steep slope.
- If the engine is stopped during travel, the emergency steering is actuated. Note that this system is only for steering in emergencies, so never stop the engine during travel. It is particularly dangerous if the engine is stopped while the machine is traveling on slopes, so be sure to avoid such situations.  
If the engine stops, place the machine immediately in a safe place.

When the machine is traveling, turn steering wheel (1) in the desired direction, then the machine turns to the direction.

Front and rear frames of this machine articulates around the connection pin (center pin) at which the two frames are connected with each other and the rear wheels follow the trace of the front wheels.

Turn the steering wheel lightly to follow the machine as it turns.

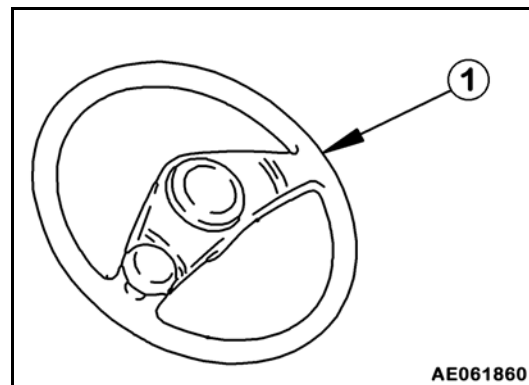

### **NOTICE**

**When steering the machine fully, if the steering wheel is turned to its stroke end, do not try to turn it further.**

**Check that play (a) of the steering wheel is in the range 50 to 100 mm {2 to 3.9 in} and the steering system operates properly.**

**If any problem is found, have your Komatsu distributor perform the inspection.**

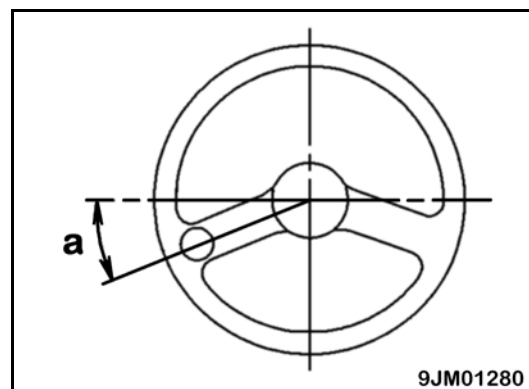

3. Keep on driving the machine forward while adjusting the digging depth by using the boom control lever.  
When you carry out digging by use of the bucket, avoid applying the digging force only to one side of the bucket.

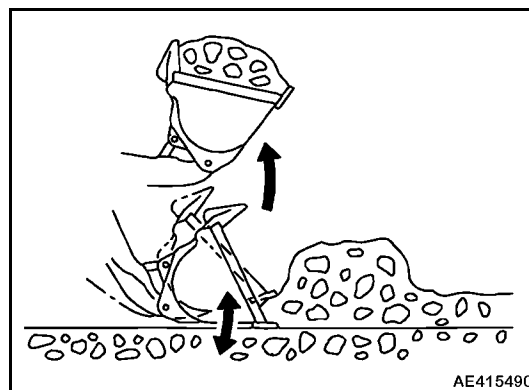

## Leveling Work

### NOTICE

- **Always drive the machine in reverse when carrying out leveling work.**  
**When it is unavoidable to drive the machine forward for the leveling work, do not set the bucket more than 20° downward. The work equipment may be damaged.**
  - **Set the E.C.S.S. switch to OFF during leveling work.**
1. Scoop earth and sand into the bucket and then, while driving the machine in reverse, tilt the bucket forward to dump earth and sand bit by bit to spread them.
  2. When leveling the ground, tilt the bucket forward so that the bucket cutting edge touches the ground, then drag the bucket by driving the machine in reverse.
  3. When performing finish leveling, scoop earth and sand into the bucket, set the boom to "FLOAT" position with the bucket horizontal, and reverse the machine.

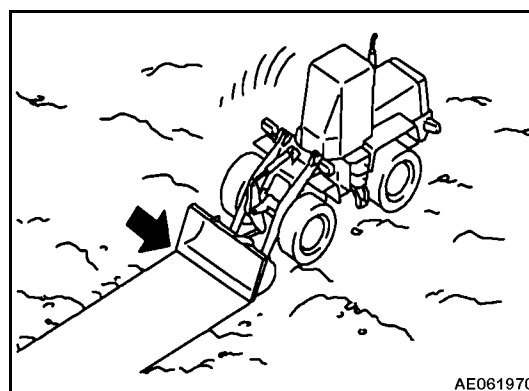

## Dozing Work

### **WARNING**

Never set the bucket to the DUMP position when carrying out the dozing operation. The work equipment may be damaged..

When performing dozing operation, set the bottom of the bucket parallel to the ground surface

## Reversing Machine After Excavation

### NOTICE

- Do not steer the machine immediately after reversing the machine. If you steer the machine when the bucket is surrounded with rocks, a large load may be applied to the bucket and machine frame, and the frame may be damaged.
- Accelerate the machine gradually after shifting the gear. If you accelerate the machine quickly, tires may slip and they may be worn or cut.

1. After the excavation, shift the gear to R2 to reverse the machine without steering.
2. If reverse travel distance (a) is approximately 1.2 to 1.5 times the overall length of the machine, the tires rotate smoothly and the tire wear is reduced.

Keep the angle between the line extended from the target materials to the machine at a right angle and the line extended from the dump truck to the machine at a right angle is  $60^\circ$ .

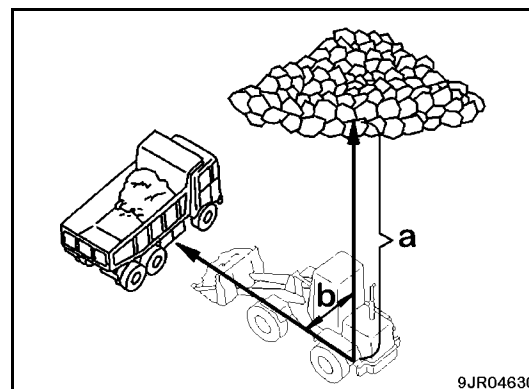

9JR04630

### Remark

Carefully steer the machine according to the stop position of dump truck and the status of target material. Determine the stop position of dump truck so that the required steering angle of the machine is less than  $20^\circ$ .

- (1) Steer the machine gently to the right or left.
  - (2) Steer the machine gently to the target materials.
  - (3) Move the machine straight to the target materials.
3. When reversing the machine, do not raise the bucket excessively. Determine the bucket height by considering the truck position, status of ground surface, travel speed, and work equipment speed. But do not raise the top end of load in the bucket above your sight at the operator's seat.

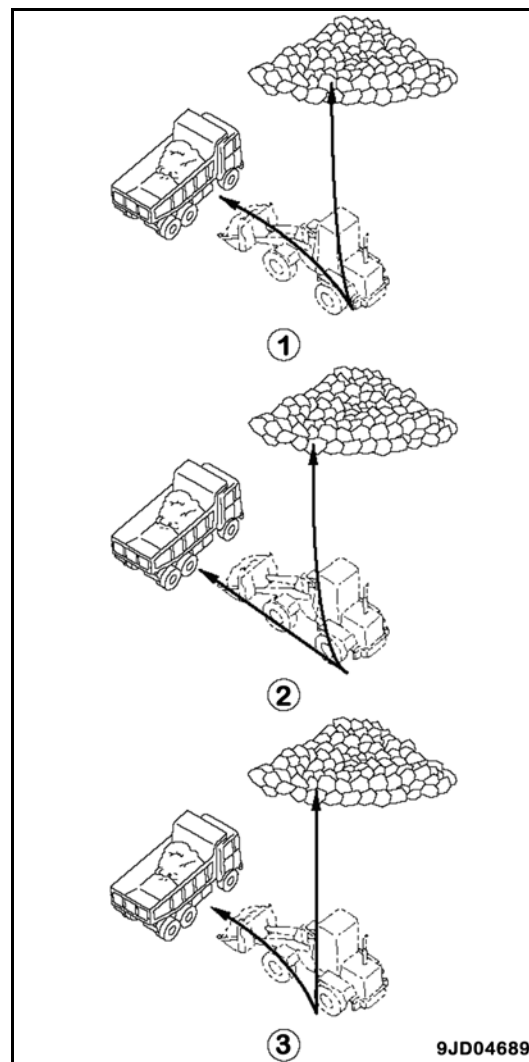

9JD04689

### Reset Lower Remote Boom Positioner

Set the boom in a position between below the horizontal level and 30 cm {12 in} above the ground, set the boom control lever to the HOLD position and then press position (a) of switch (1) for more than one second.

The buzzer beeps indicating that the LOWER stop position is reset.

If the boom control lever is set to the FLOAT position while the stop position is reset, the boom is set to the float mode and moved freely by the external force applied.

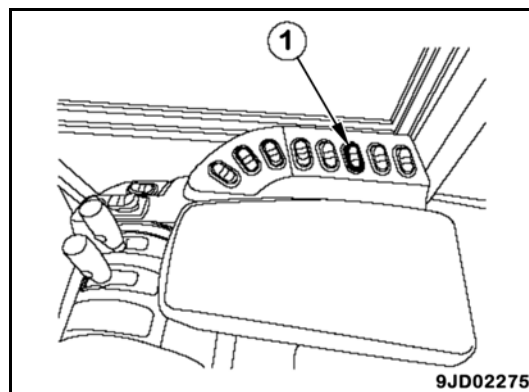

9JD02275

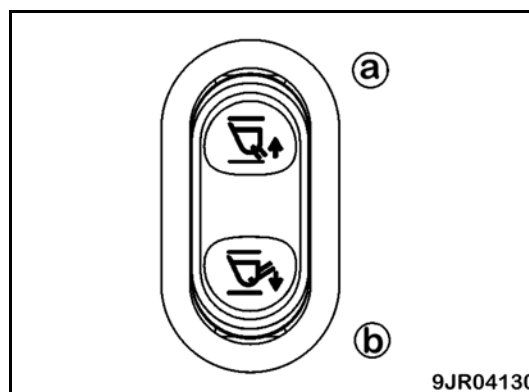

9JR04130

**Remark**

- When the boom is above the horizontal level, the boom RAISE stop position setting and its reset operation can be made. And when the boom is below the horizontal level, the boom LOWER stop position setting and its reset operation can be made.
- When the remote positioner is enabled, the pilot lamp lights up on the machine monitor.

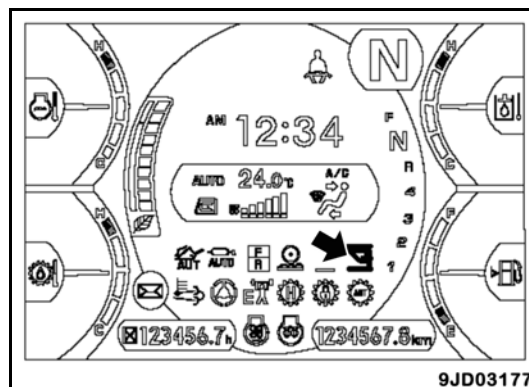

9JD03177

- (A): When only boom RAISE positioner is enabled
- (B): When only boom LOWER positioner is enabled
- (C): When both boom RAISE and LOWER positioners are enabled

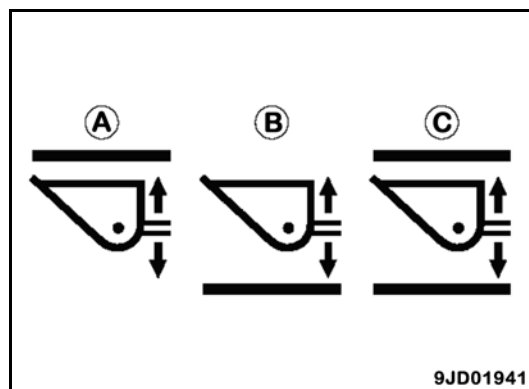

9JD01941

Securing Position

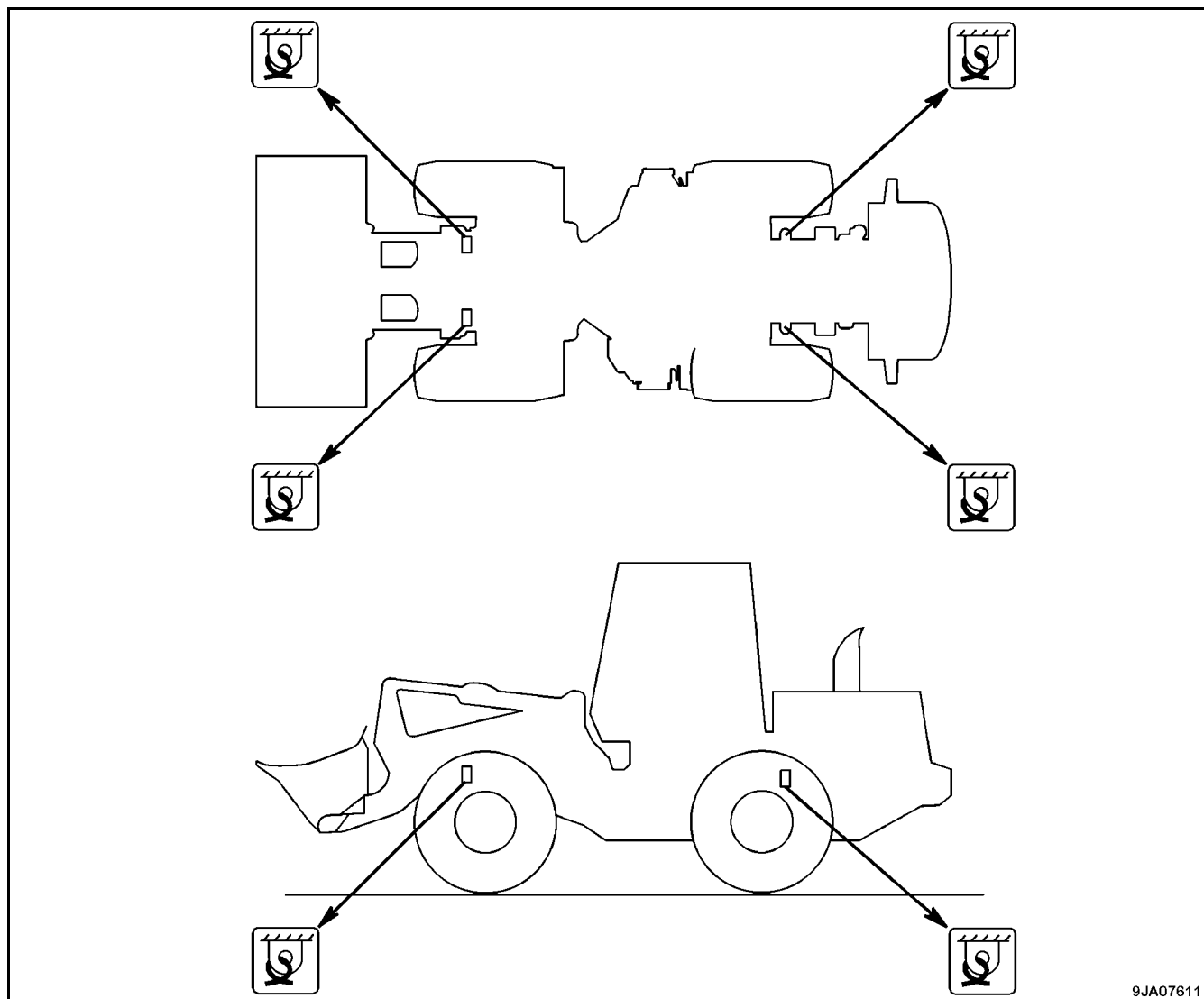

9JA07611

4. Set the parking brake switch to ON (A) position (applied), then set it to OFF (B) position (released).  
The parking brake is released.

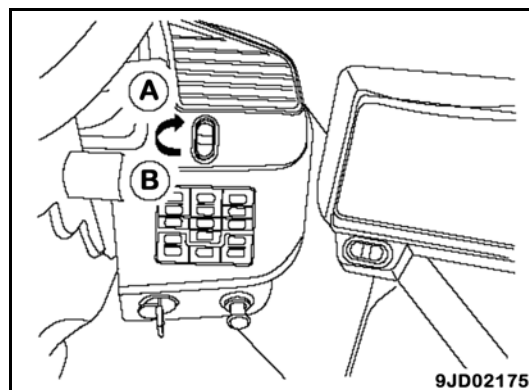

5. To restore the function of the parking brake, turn grip (3) of the cancel valve clockwise to close the cancel valve, then turn locknut (2) clockwise to lock.

Tightening torque

- Grip (3):  $20 \pm 5 \text{ N}\cdot\text{m}$  ( $2.0 \pm 0.5 \text{ kgm}$ ) {  $15 \pm 4 \text{ lbf ft}$  }
- Locknut (2):  $20 \pm 5 \text{ N}\cdot\text{m}$  ( $2.0 \pm 0.5 \text{ kgm}$ ) {  $15 \pm 4 \text{ lbf ft}$  }

6. Set the parking brake switch to ON (A) position.  
The parking brake is applied.  
To release the parking brake again, repeat the procedure in Steps 1 to 5.

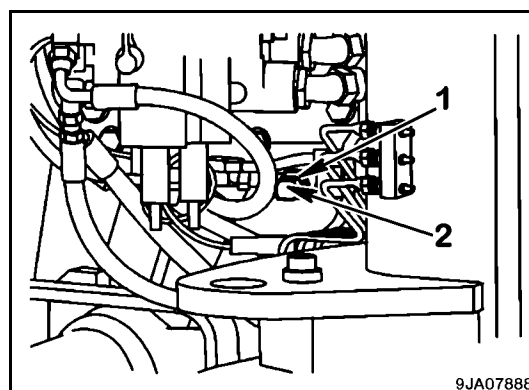

#### Remark

*If the pressure in the brake accumulator is low, the parking brake caution lamp does not go out or the alarm buzzer sounds (continuous beep). In this case, release the brake. For details, see "Releasing Method with Adjustment Bolt" on page 2-253.*

## Chassis

- Always contact your Komatsu distributor when dealing with the **Remedy** items indicated with (\*) in the remedy column.
- In cases of problems or causes which are not listed below, contact your Komatsu distributor for repairs.

Problem	Main Causes	Remedy
<b>Transmission</b>		
Engine runs but machine does not move	Parking brake applied	Release parking brake.
	Directional lever not being in position	Set the lever completely in position.
	Lack of oil in transmission case	Add oil to specified level. See Maintenance when required.
Machine moves slowly and lacks power with engine running at full throttle	Lack of oil in transmission case	Add oil to specified level. See Maintenance when required.
	Clogged screen	Disassemble and clean. (*)
Oil overheats	Insufficient or excessive oil in transmission case	Add oil to specified level or drain excessive oil. See Maintenance when required.
	Traveling in incorrect speed range	Use correct speed range.
	Torque converter stall operation too long	Reduce stall time.
	Engine overheating	Check engine. (*)
Noise is heard	Lack of oil in transmission case	Add oil to specified level. See Maintenance when required
<b>Axle</b>		
Noise is heard	Lack of oil	Add oil to specified level. See Maintenance when required
	Improper oil used (for machines with anti-slip differential)	Change to specified oil.
<b>Brake</b>		
Even when pedal is depressed, brake does not work	Disc worn to wear limit	Replace disc. (*)
	Defective hydraulic system	Check and repair. (*)
	Insufficient oil	Add oil to specified level. See Every 100 hours maintenance
	Air in brake system	Bleed air (*)
Brake drags or remains applied	Clogged vent hole of brake valve	Clean
Brake squeals	Worn disc	Replace disc. (*)
	Large amount of water in axle oil	Change axle oil.
	Deteriorated axle oil due to over use of brake	Change axle oil.

## **OUTLINES OF SERVICE**

- Always use Komatsu genuine parts for replacement parts, grease, or oil.
- When changing or adding oil, do not mix different types of oil.
- When changing the type of oil, drain all the old oil and fill completely with the new oil.
- Always replace the filter at the same time.
  - There is no problem if the small amount of oil remaining in the piping mixes with the new oil.
- Unless otherwise specified, when the machine is shipped from the factory, it is filled with the oil and coolant listed in the following table.















<b>Item</b>	<b>Type</b>
Engine oil pan	Engine oil EO15W40-LA (Komatsu genuine)
Transmission case	Power train oil TO10 (Komatsu genuine)
Hydraulic oil system	Power train oil TO10 (Komatsu genuine)
Axle	Axle oil AXO80 (Komatsu genuine)
Radiator	Non-Amine Engine Coolant (AF-NAC) (Komatsu genuine) (density: 30% or above)

## **HANDLING OIL, FUEL, COOLANT, AND PERFORMING OIL CLINIC**

### **Oil**

- Oil is used in the engine and hydraulic equipment under extremely severe conditions (high temperature, high pressure); it deteriorates with use.
- Always use oil that matches the grade and maximum and minimum ambient temperatures recommended in this manual.
  - ★ See “RECOMMENDED FUEL, COOLANT, AND LUBRICANTS” on page 3-11.
- Even if the oil is not dirty, always change the oil after the specified interval.
- Oil corresponds to blood in the human body; it provides life-sustaining properties. Always be careful when handling it to prevent any impurities (water, metal particles, dirt, etc.) from getting into the oil.
  - The majority of problems with machines are caused by the entry of such impurities.
  - Be very careful not to contaminate the oil when storing or adding it.
- Never mix oils of different grades or brands.
- Always add the specified amount of oil.
  - Having too much oil or too little oil both cause problems.
- If the oil in the work equipment is not clear, there is probably water or air getting into the circuit.
  - ★ In such cases, contact your Komatsu distributor for inspection and repair.
- When changing the oil, always replace the related filters at the same time.
- Komatsu strongly recommends that you have an analysis made of the oil periodically to check the condition of your machine.
  - ★ For details of this service, contact your Komatsu distributor.
  - ★ See “KOWA Analysis Items” on page 3-8.
- When using commercially available oil, it may be necessary to reduce the oil change interval.
  - Komatsu recommends that you use the Komatsu oil clinic to carry out a detailed check of the characteristics of the oil.

Symbols used in the lubrication standard chart

Symbol	Meaning of symbol	Symbol	Meaning of symbol
	Read Operation and Maintenance Manual		Supply grease
	Change engine oil		Check engine oil level
	Change hydraulic oil		Check hydraulic oil level
	Change power train oil		Change power train oil filter
	Replace engine oil filter		Replace hydraulic oil filter
	Replace hydraulic tank breather element		Replace fuel filter
	Replace KCCV filter		Change axle oil

AJD00111

**Replace Element**

1. Open the engine side cover on the right side of the machine.
2. Remove clips (1) in three places and remove cover (2).

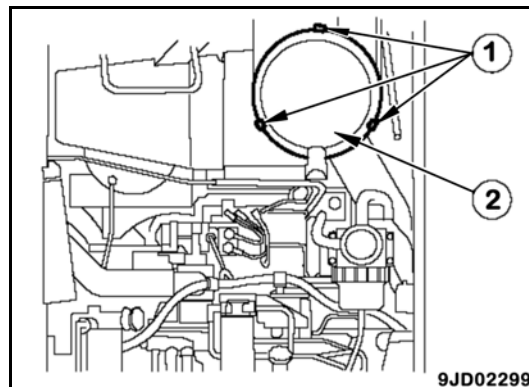

3. Remove the outer element (3).  
Do not remove inner element (4) at this time.

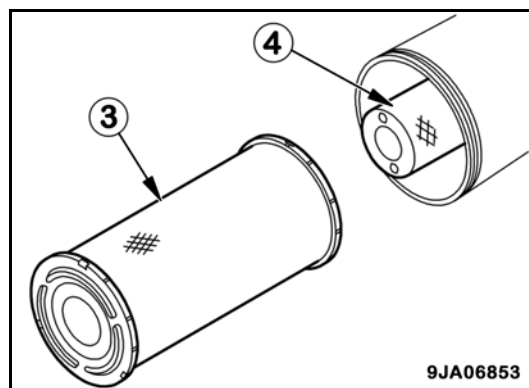

4. Clean the inside of the air cleaner body and dust cup.
5. Remove inner element (4), then quickly install the new inner element.
6. Set a new outer element (3) at the place, replace O-ring (6) with a new one, install cover (2) and fix them with mounting clip (1).

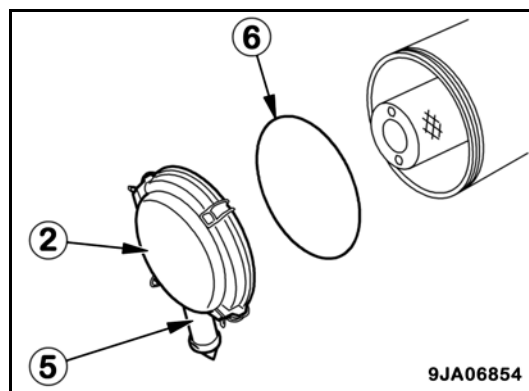

7. Press the button of the dust indicator to return the yellow piston to the original position.
8. Close the engine side cover on the right side of the machine.

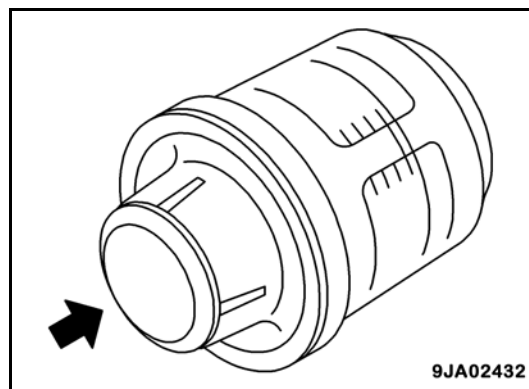

## Clean Radiator Fin and Cooler Fin

### **WARNING**

- When the engine is running, do not open the engine side cover. When cleaning the fin, stop the engine rotation completely.
- If compressed air, high-pressure water, or steam hits your body directly or dirt is scattered by the compressed air, high-pressure water, or steam, there is a danger of personal injury. Always wear protective equipment such as protective eyeglasses and dust mask.

Carry out this procedure if there is any mud or dirt stuck to the radiator.

### Clean By Cooling Fan Reverse Turn

#### NOTICE

**When rotating the fan in the reverse direction, be extremely careful of dirt that may fly out and be sure that no material, etc., gets wound up in the fan.**

**Since dust or dirt may fly up, check that nobody is around while the fan is rotating in reverse.**

On the job site where the dirt sticks easily to the radiator or cooler, set the automatic cooling fan to rotate the fan in reverse. This will blow off any dirt stuck to the radiator or cooler, and can extend the cleaning interval.

### Manual Fan-Reverse Operation

#### NOTICE

- **Never rotate the fan in reverse by hand when carrying out the operation.**
- **Before operating the manual reverse rotation of the fan, set the engine speed to low idle.**

For the manual reverse rotation of the fan, see “Manual Fan Reverse Mode” on page 2-64.

After reverse rotation of the fan is started, set the engine speed to high idle.

Select the time for running engine at high idle as follows according to the condition of clogging.

Normal clogging: one to two minutes

Excessive clogging: two to three minutes

When the cleaning is completed, set the engine speed to low idle and restore the rotation of the fan to normal.

### Automatic Fan-Reverse Operation

For the automatic reverse rotation of the fan, see “Automatic Fan Reverse Mode” on page 2-66.

#### Remark

*When the fan rotation direction is switched, the reverse rotation pilot lamp flashes.*

*After a heavy load operation, the fan rotation direction may not change to protect the machine.*

*Set the engine speed to low idle and wait until the oil and coolant temperature goes down before operating the switch.*

6. After cleaning, install the element to the breather body.  
At that time, install the element in correct direction.  
Direct the surface marked (5) towards up and install.
7. Install cover (3).
8. Tighten nut (2).  
Tightening torque: 10 to 14 N·m {1.0 to 1.4 kgm, 64 to 89 lbf in}
9. Close the engine side cover.

### NOTICE

**If the element is dirty or damaged, replace with a new one.**

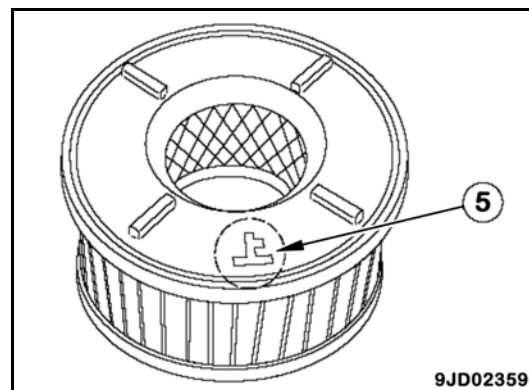

## Check Function of Accumulator

For details of the handling of the accumulator, see “Handling Accumulator and Gas Spring” on page 1-49.

### Brake Accumulator

If the engine stops during travel, the brake can be applied with the oil pressure in the accumulator as an emergency operation.

1. Park the machine on a level ground and lower the work equipment to the ground.
2. Apply the parking brake.
3. Start the engine and run it at medium speed for one minute, and then stop it.
4. Turn the starting switch to the ON position and depress the brake pedal several times.
  - If the brake oil pressure caution lamp does not light up after you depress the brake pedal six times, the gas pressure in the accumulator is normal.
  - If the brake oil pressure caution lamp light up, when you depress the brake pedal five times or less, the accumulator gas pressure may be low. Ask your Komatsu distributor for inspection.

### Remark

*The inspection must be done within five minutes after the engine stops. If the engine is kept stopped, the gas pressure in the accumulator lowers and the inspection cannot be made.*

## Lubricate Work Equipment

1. Pump in grease through the grease fittings marked by arrows by using a grease pump.
2. After greasing, wipe off any old grease that is pushed out.

### NOTICE

Shorten the greasing interval than usual in a jobsite where the machine works for severe operations, or for continuous operations that last eight or more hours.

Grease the machine once for every ten hours until the initial 100 hours are reached.

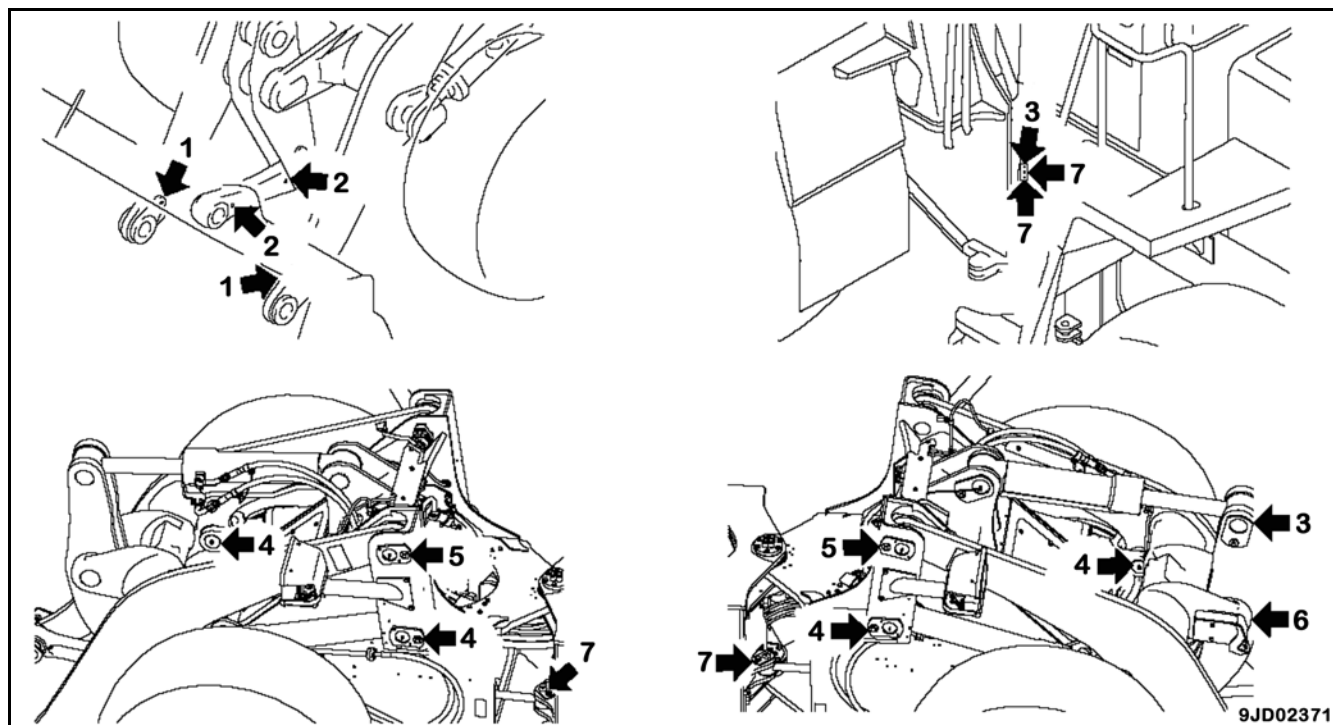

- |                                      |                                         |
|--------------------------------------|-----------------------------------------|
| (1) Bucket pin (two places)          | (5) Boom pivot pin (two places)         |
| (2) Bucket link pin (two places)     | (6) Bell crank pin (one place)          |
| (3) Bucket cylinder pin (two places) | (7) Steering cylinder pin (four places) |
| (4) Lift cylinder pin (four places)  |                                         |

**Lubricate Center Hinge Pin**

1. Using a grease pump, pump in grease through the grease fittings marked indicated by arrows.
2. After greasing, wipe off any old grease that is pushed out.
  - Center hinge pin (two places)

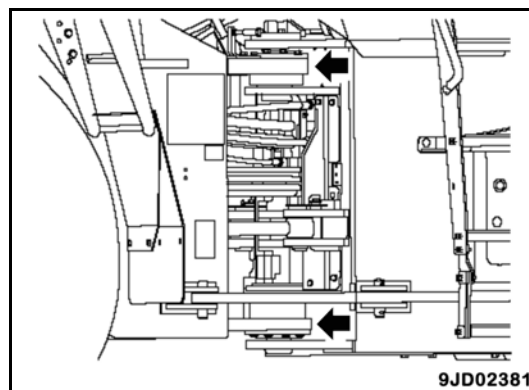

**Lubricate Drive Shaft Center Support**

1. Using a grease pump, pump in grease through the grease fittings marked indicated by arrows.
2. After greasing, wipe off any old grease that is forced out.
  - Drive shaft center support (one place)

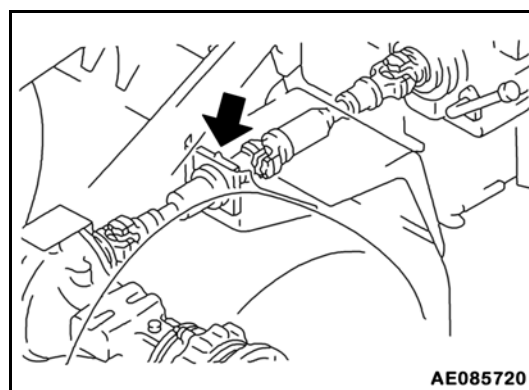

## Replace KCCV Filter Element

# WARNING

After the engine is operated, all parts are at high temperature, so do not replace the filter element immediately. Wait until the temperature of all parts drops. Always stop the engine before starting the part replacement.

### NOTICE

- Always use Komatsu genuine parts for replacement parts.
- If the engine is operated without the filter element, the turbocharger and aftercooler will become dirty and their performance will lower and that can cause engine problems such as overrun caused by suction of oil. Therefore, do not start the engine without the filter element.
- The filter element cannot be cleaned. If the filter element is cleaned or refurbished, the filter performance lowers. As a result, the turbocharger and aftercooler become dirty and the crankcase pressure increases. Never reuse the filter element since it can cause an engine failure.
- After the filter element is replaced, if KCCV is not assembled correctly, oil or blowby gas may leak. Replace the filter element in the correct procedure.

Prepare the special wrench for KCCV and a container to catch the oil.

The KCCV ventilator is located at the positions shown in the figure on the right.

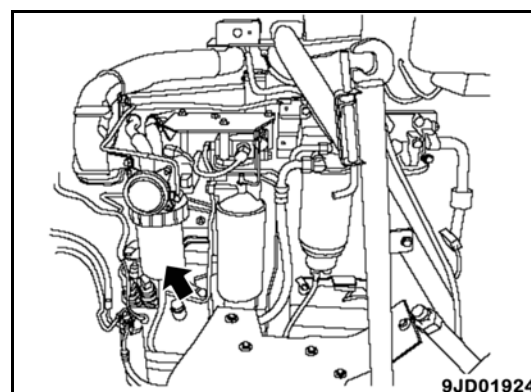

For how to use the special wrench, see the figure on the right.

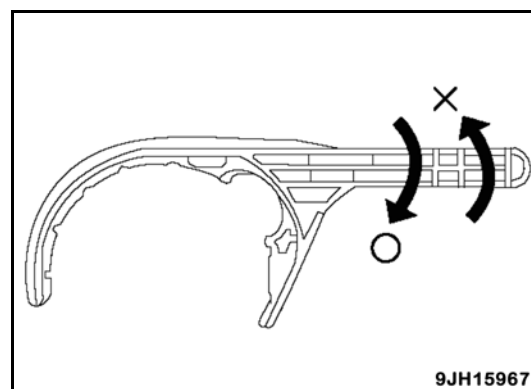

# **SPECIFICATIONS**

**Directional Selector Switch**

**⚠ WARNING**

Do not maintain the directional selector switch at the intermediate position between positions (F) and (N), or between positions (N) and (R). If you do so, the alarm buzzer sounds and the transmission is set in NEUTRAL.

This switch (4) is used to set the travel direction to forward, neutral, and reverse.

The basic operation is as follows:

- Position (F): Forward
- Position (N): Neutral
- Position (R): Reverse

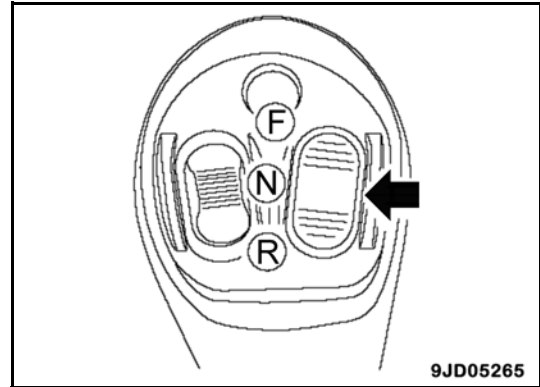

Before using this switch to change the travel direction, set the directional lever to the NEUTRAL position and set directional selector switch (A) of R.H. switch panel to position (a).

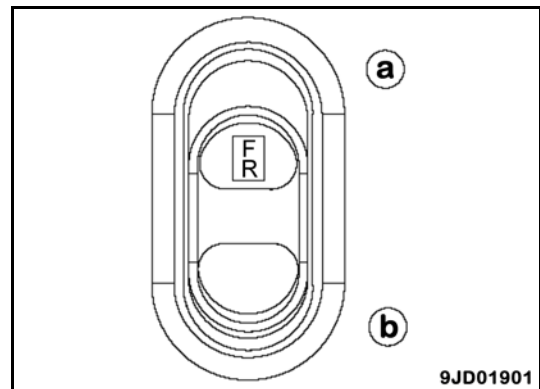
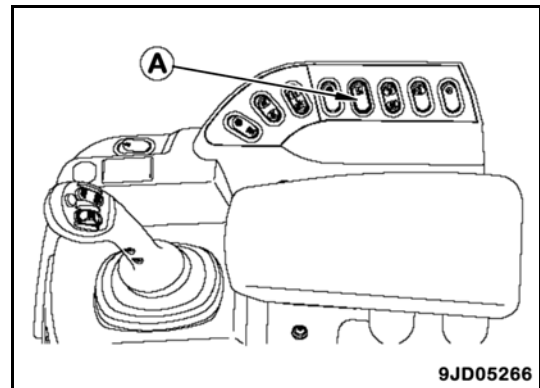

CLICK HERE TO **DOWNLOAD** THE COMPLETE MANUAL

- Thank you very much for reading the preview of the manual.
- You can download the complete manual from: [www.heydownloads.com](http://www.heydownloads.com) by clicking the link below



- Please note: If there is no response to CLICKING the link, please download this PDF first and then click on it.

CLICK HERE TO **DOWNLOAD** THE COMPLETE MANUAL