

Operation & Maintenance Manual

WHEEL LOADER

WA150-5

SERIAL NUMBERS 73685 and up

⚠ WARNING

Unsafe use of this machine may cause serious injury or death. Operators and maintenance personnel must read this manual before operating or maintaining this machine. This manual should be kept near the machine for reference and periodically reviewed by all personnel who will come into contact with it.

NOTICE

Komatsu has Operation & Maintenance Manuals written in some other languages. If a foreign language manual is necessary, contact your local distributor for availability.

KOMATSU

CLICK HERE TO **DOWNLOAD** THE COMPLETE MANUAL

- Thank you very much for reading the preview of the manual.
- You can download the complete manual from: www.heydownloads.com by clicking the link below



- Please note: If there is no response to CLICKING the link, please download this PDF first and then click on it.

CLICK HERE TO **DOWNLOAD** THE COMPLETE MANUAL

INITIAL 250 HOURS SERVICE	4- 16
WHEN REQUIRED	4- 17
CHECK BEFORE STARTING	4- 37
EVERY 50 HOURS SERVICE	4- 38
EVERY 100 HOURS SERVICE	4- 39
EVERY 250 HOURS SERVICE	4- 42
EVERY 500 HOURS SERVICE	4- 48
EVERY 1000 HOURS SERVICE	4- 54
EVERY 2000 HOURS SERVICE	4- 58
EVERY 4000 HOURS SERVICE	4- 64
SPECIFICATIONS	5- 1
SPECIFICATIONS	5- 2
ATTACHMENTS, OPTIONS	6- 1
SELECTING BUCKET AND TIRES	6- 2
HANDLING BATTERY DISCONNECTOR SWITCH	6- 3
EXPLANATION OF COMPONENTS	6- 3
HANDLING	6- 3
HANDLING MACHINES EQUIPPED WITH KOMTRAX	6- 4
BASIC PRECAUTIONS	6- 4
INDEX	7- 1

(17) Prohibition of engine start by short-circuiting (09842-A0481)



Start the engine only after sitting down in the operator's seat.

Do not attempt to start the engine by short-circuiting the engine starting circuit. Such an act may cause a serious bodily injury or fire.

PRECAUTIONS FOR OPERATION

STARTING ENGINE

If there is a warning tag hanging from the work equipment control lever, do not start the engine or touch the levers.

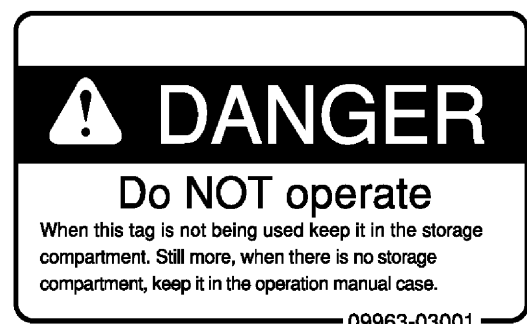
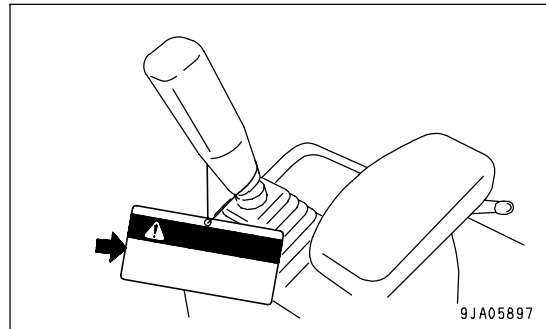

CHECKS BEFORE STARTING ENGINE

Carry out the following checks before starting the engine at the beginning of the day's work.

- Remove all dirt from the surface of the window glass to ensure a good view.
- Remove all dirt from the surface of the lens of the front lamps, working lamps, and rear combination lamp, and check that they light up correctly.
- Check the coolant level, fuel level, and oil level in engine oil pan, check for clogging of the air cleaner, and check for damage to the electric wiring.
- Check that there is no mud or dust accumulated around the movable parts of the accelerator pedal or brake pedal, and check that the pedals work properly.
- Adjust the operator's seat to a position where it is easy to carry out operations, and check that there is no damage or wear to the seat belt or mounting clamps.
- Check that the gauges work properly, check the angle of the lights and working lamps, and check that the control levers are all at the neutral position.
- Before starting the engine, make sure that the work equipment lock lever is in the LOCK position.
- Adjust the mirrors so that the rear of the machine can be seen clearly from the operator's seat. See "ADJUST REAR VIEW MIRROR (PAGE 3-80)".
- Check that there are no persons or obstacles above, below, or in the area around the machine.

PRECAUTIONS WHEN STARTING

- Start and operate the machine only while seated.
- Do not attempt to start the engine by short-circuiting the engine starting circuit. Such an act may cause a serious bodily injury or fire.
- When starting the engine, sound the horn as a warning.
- Do not allow anyone apart from the operator to ride on the machine.
- When starting the engine, always check that the work equipment control levers are at the HOLD position.

STARTING WITH BOOSTER CABLES

If any mistake is made in the method of connecting the booster cables, it may cause the battery to explode, so always do as follows.

- When starting with a booster cable, carry out the starting operation with two workers (one worker sitting in the operator's seat and the other working with the battery).
- When starting from another machine, do not allow the two machines to touch.
- When connecting the booster cables, turn the starting switch OFF position for both the normal machine and problem machine. There is a hazard that the machine will move when the power is connected.
- Be sure to connect the positive (+) cable first when installing the booster cables. Disconnect the negative (-) cable (ground side) first when removing them.
- When removing the booster cables, be careful not to let the booster cable clips touch each other or to let the clips touch the machine.
- Always wear safety glasses and rubber gloves when starting the engine with booster cables.
- When connecting a normal machine to a problem machine with booster cables, always use a normal machine with the same battery voltage as the problem machine.
- For details of the starting procedure when using booster cables, see "STARTING ENGINE WITH BOOSTER CABLE (PAGE 3-122)" in the OPERATION section.

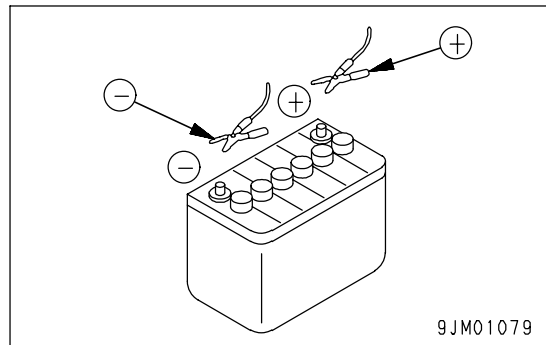
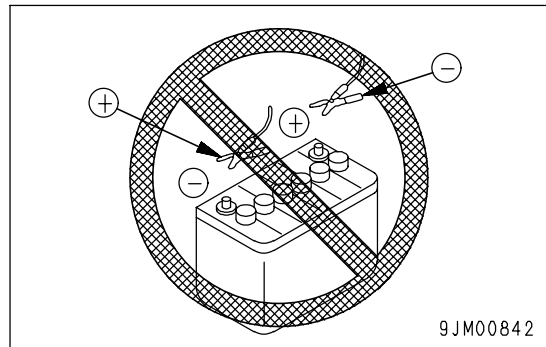

E01: When a failure occurs in the mechanical system, such as a drop in the level of the engine coolant, the maintenance location is displayed. If the maintenance caution lamp lights up at the same time, inspect and perform maintenance of the item indicated after completion of the day's work or when changing shifts. If "MAINTENANCE" is displayed together with E01, check the failure code and ask for repairs to be carried out.

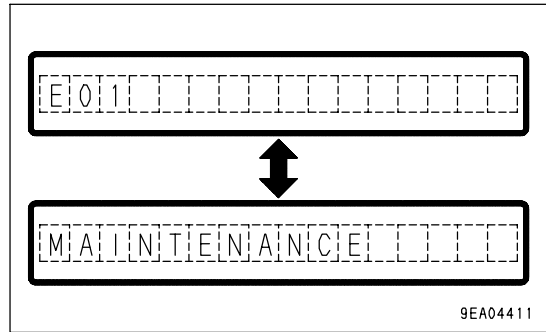

REMARK

"E01" is displayed on the character display, and then "MAINTENANCE" or the part of the machine requiring inspection, filling of fluid, or replacement is displayed on the bottom line.

E00: If travel speed overrun is displayed, ease the accelerator pedal back to reduce speed.

REMARK

"E00" is displayed on the character display, and then "OVERRUN PROTECT" and "E00" are displayed in turn for 3 seconds each.

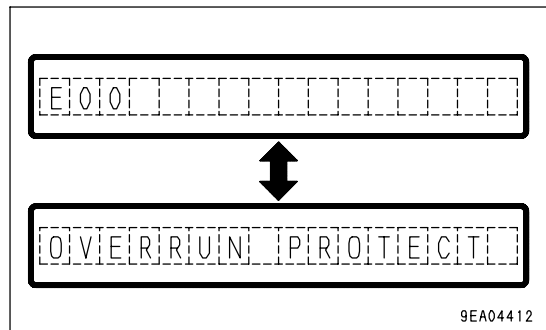

INSPECTION AND MAINTENANCE ITEMS

CAUTION

If these lamps light up, stop operations quickly and carry out the following action.

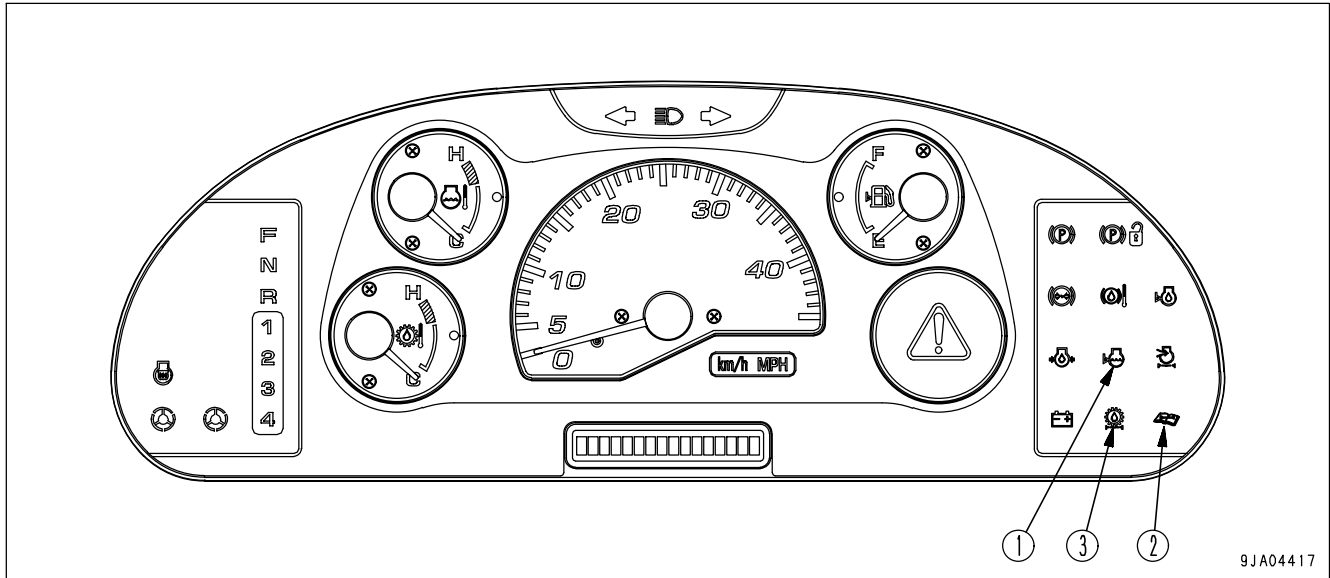

- (1) Radiator coolant level caution lamp
- (2) Maintenance caution lamp
- (3) HST oil filter clogging caution lamp

RADIATOR COOLANT LEVEL CAUTION LAMP

This lamp (1) lights up to warn the operator that the coolant level in the radiator has gone down.

During checks before starting (when the starting switch is turned to the ON position but the engine is not started), this monitor lights up if the coolant level in the radiator is low.

At the same time, "E01" and "COOLANT LOW" are displayed on the character display in turn. Check the coolant level in the radiator sub-tank, and add coolant.

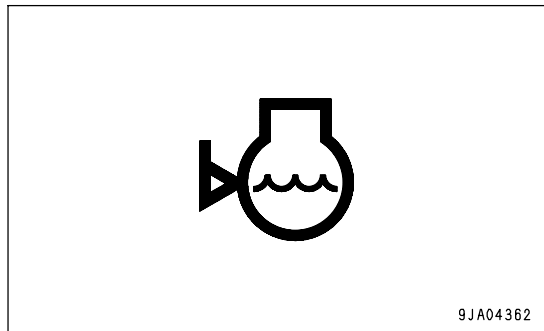

During operation (engine running)

If the coolant level in the radiator becomes too low, the radiator coolant level caution lamp will light up.

At the same time, "E01" and "COOLANT LOW" are displayed on the character display in turn. Stop the engine, check the coolant level in the radiator sub-tank, and add coolant.

SWITCHES

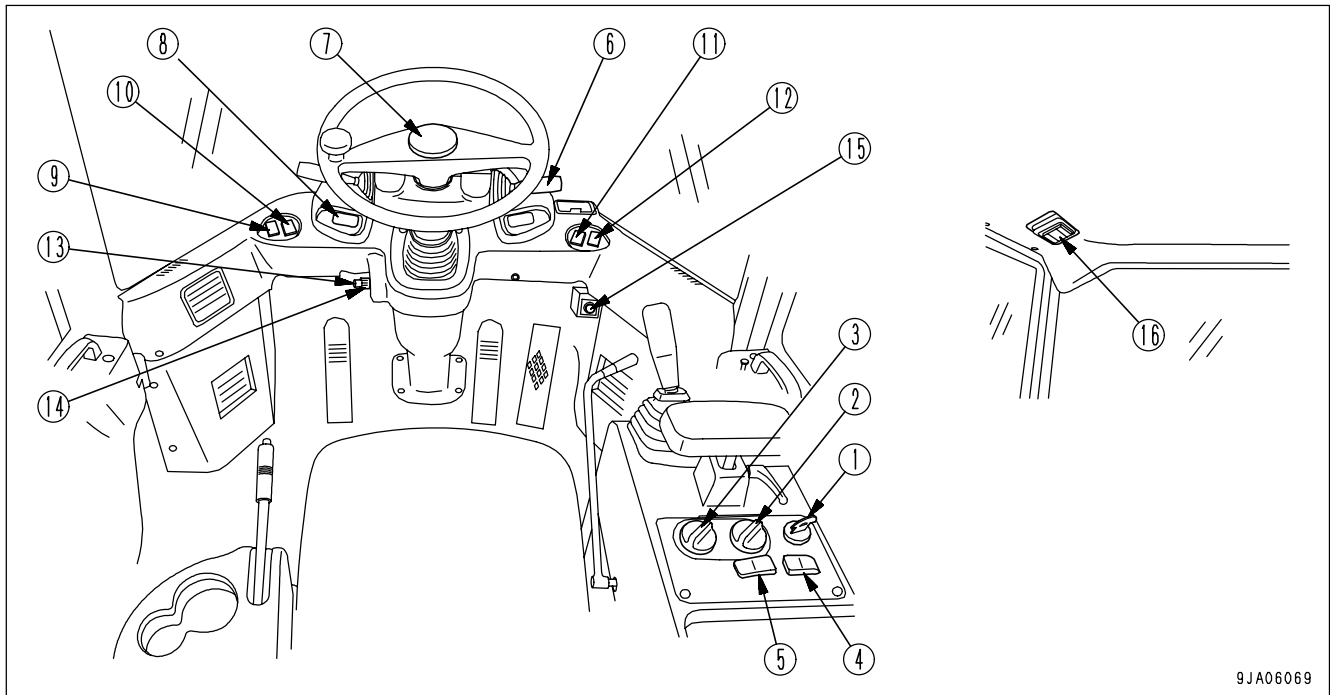

9JA06069

- | | |
|---|---|
| (1) Starting switch | (8) Hazard lamp switch |
| (2) Speed range selector switch | (9) Front working lamp switch |
| (3) Variable shift control switch | (10) Rear working lamp switch |
| (4) Traction control switch | (11) Monitor panel mode selector switch 1 |
| (5) E.C.S.S. (Electronic Controlled Suspension System) switch (if equipped) | (12) Monitor panel mode selector switch 2 |
| (6) Lamp switch | (13) Front wiper switch |
| (6) Turn signal lever | (14) Rear wiper switch |
| (6) Dimmer switch | (15) Cigarette lighter |
| (7) Horn button | (16) Room lamp switch |

STARTING SWITCH

This switch (1) is used to start or stop the engine.

OFF position

The key can be inserted or with drawn. The switches for the electric system are all turned off and the engine is stopped.

ON position

In this position, electric current flows to the charging circuit, lamp circuit, and accessory circuit.

Keep the starting switch key at the ON position while the engine is running.

START position

This is the engine-start position. Keep the key at this position during cranking. Immediately after starting the engine, release the key. It will automatically return to the ON position.

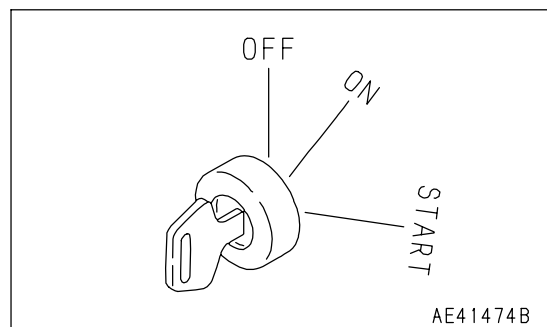

AE41474B

PARKING BRAKE LEVER

**WARNING**

Always apply the parking brake when leaving the machine or when parking it.

NOTICE

- Never use the parking brake lever to slow the machine when traveling except in an emergency. The parking brake may be damaged and this may lead to a serious accident. Apply the parking brake only after the machine has stopped.
- If the parking brake has been used as an emergency brake when traveling at high speed (near the maximum speed), contact your Komatsu distributor to have the parking brake checked for any abnormality.

This lever (6) operates the parking brake.

Pull the lever up to the LOCK position to actuate the parking brake.

At the same time, the parking brake pilot lamp will light up.

To release the brake, pull the lever, then press button (A) at the tip of the lever and return the lever to the FREE position. At the same time, the parking brake pilot lamp will go out.

REMARK

If the directional lever is placed at the FORWARD or REVERSE position with the parking brake still applied, the central warning lamp will light up and the buzzer will sound.

Before operating the directional lever, check that the parking brake lever is at the FREE position.

When the parking brake is applied, the machine will not move even if the directional lever is operated.

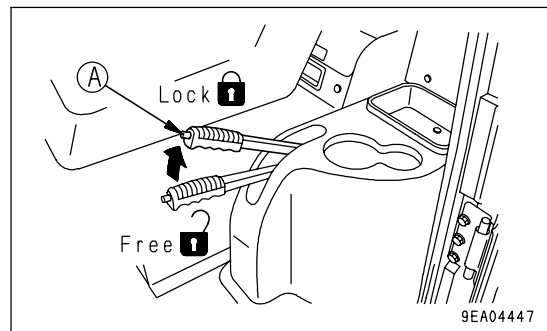

METHOD OF OPERATION

LISTENING TO RADIO

1. Turn radio power switch (1) ON.
2. "BAND" switch (2) is used to select MW (AM) or FM.
3. Use the preset switch or tuning switch (3) to select the station.
4. Adjust the volume and tone as desired.
5. To turn the radio OFF, turn VOL knob (1) to the left until a click is heard.

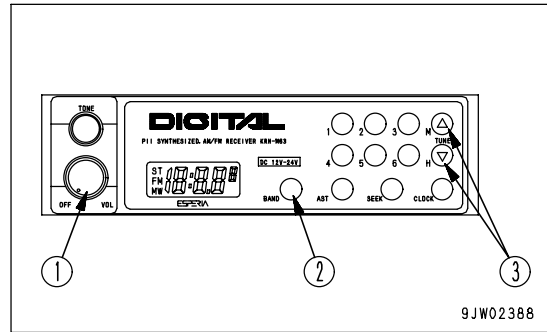

METHOD FOR SELECTING STATION AUTOMATICALLY

When the "SEEK" switch is pressed, it moves up to higher frequencies and when it finds a station that can be received, it stops automatically.

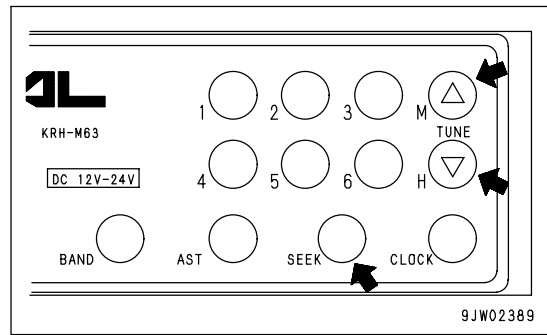

METHOD FOR SELECTING STATION MANUALLY

When the TUNE button Δ is pressed, the frequency goes up; when the ▽ button is pressed, the frequency goes down. If it is kept pressed, the frequency changes continuously.

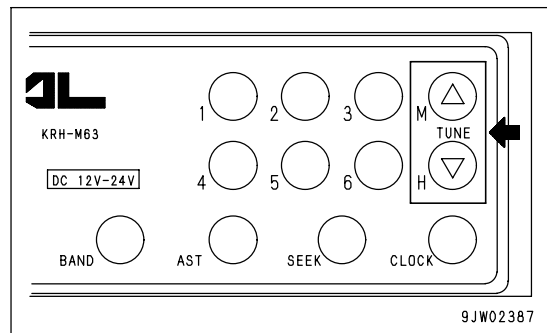

REVERSING TAPE

When listening to the tape, press both FAST FORWARD, REWIND buttons (A) and (B) at the same time lightly.

When this is done, the tape direction display will be reversed.

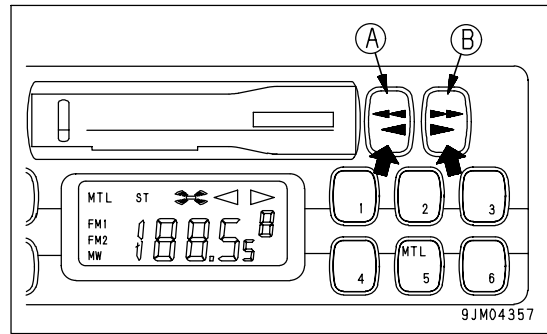
**PRECAUTIONS WHEN USING****WARNING**

- If a voltage greater than the specified voltage is input, it may cause fire, electrocution, or other failure. Never input any voltage other than the specified voltage.
- Places inside the radio are under high voltage. Do not remove the cover.
- Do not carry out any modifications. This may cause fire, electrocution, or other failure.
- If the sound cannot be heard, nothing is displayed, or any other problem occurs, turn off the power switch and ask your Komatsu distributor to make repairs without delay.

- Stow the antenna when traveling in places with low overhead clearance.
- To ensure safety during operations, keep the volume at a level where it is possible to hear other machines.
- If water gets inside the speaker case or radio (auto tuning), it may cause a serious problem, take care not to let water get in these items.
- Do not wipe the scales or buttons with solvent such as benzene or thinner. Wipe with a dry soft cloth. If the dirt cannot be removed easily, soak the cloth with alcohol.

NOTICE**Handling cassette tape**

- Clean the tape head approx. once a month with a commercially available head cleaning tape.
- Do not leave the tape any place where it is exposed to direct sunlight, any place that is excessively dusty, or any place where there is a magnetic field.
- Do not use 120-minute tapes. The tape is thin and it easily gets caught up inside the machine.
- If the tape is slack, it easily gets caught up inside the machine. Use a pencil to wind in the tape to remove any slack.
- Do not use any cassette tape if the label has started to come off. It may cause defective rotation, or it may be impossible to get the tape out of the machine.

CLICK HERE TO **DOWNLOAD** THE COMPLETE MANUAL

- Thank you very much for reading the preview of the manual.
- You can download the complete manual from: www.heydownloads.com by clicking the link below



- Please note: If there is no response to CLICKING the link, please download this PDF first and then click on it.

CLICK HERE TO **DOWNLOAD** THE COMPLETE MANUAL

CHECK WATER SEPARATOR

The water separator separates water mixed in the fuel. If float (1) goes above water drain line (2), drain the water as follows.

1. Loosen drain plug (3) and drain the accumulated water until the float (1) reaches the bottom.
2. Tighten drain plug (3).
3. If the air is sucked into the fuel line when draining water, be sure to bleed air in the same manner as for the fuel filter. See "REPLACE FUEL FILTER CARTRIDGE (PAGE 4-50)".

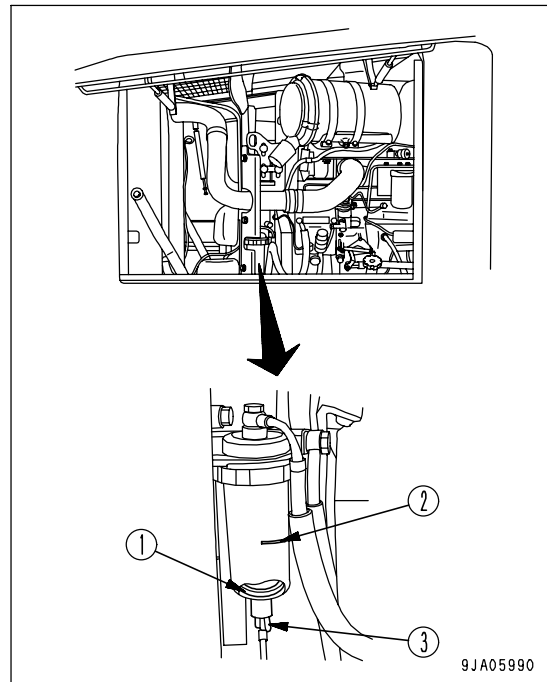
**CHECK DUST INDICATOR**

1. Check that the red piston has not appeared in the transparent portion of dust indicator (1).
2. If the red piston has appeared, clean or replace the element immediately.

For details on cleaning the element, see "CHECK, CLEAN, OR REPLACE AIR CLEANER ELEMENT (PAGE 4-17)".

3. After checking, cleaning, or replacing the air cleaner element, press the knob of dust indicator (1) to return the red piston to its original position.

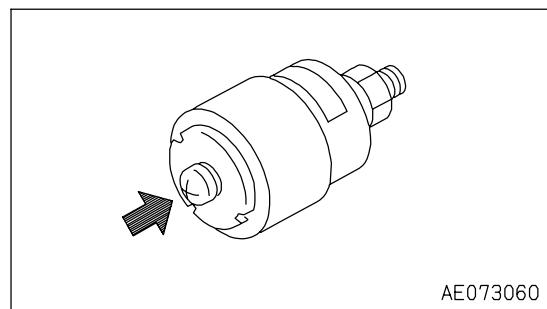
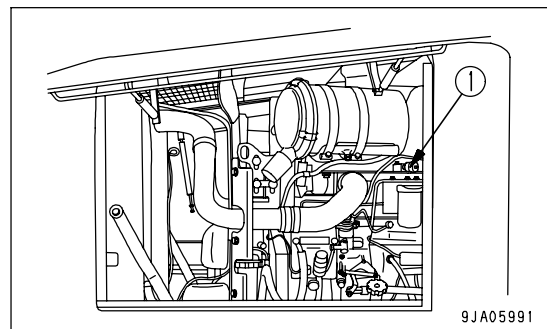

ADJUST REAR VIEW MIRROR

Sit in the operator's seat and adjust the rear view mirror so that you can see properly to the rear.

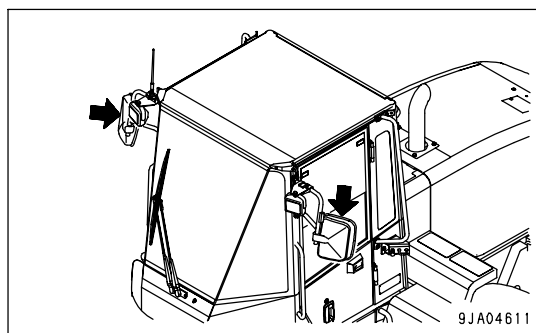

CHANGING DIRECTION



WARNING

- When changing direction between FORWARD and REVERSE, check that the new direction of travel is safe. There is a blind spot behind the machine, so be particularly careful when changing direction to travel in reverse.
- Do not switch between FORWARD and REVERSE when traveling at high speed.
When switching between FORWARD and REVERSE, depress the brake to reduce the travel speed sufficiently, then change the direction of travel. (Max.speed for changing direction: 13 km/h (8.1 MPH))

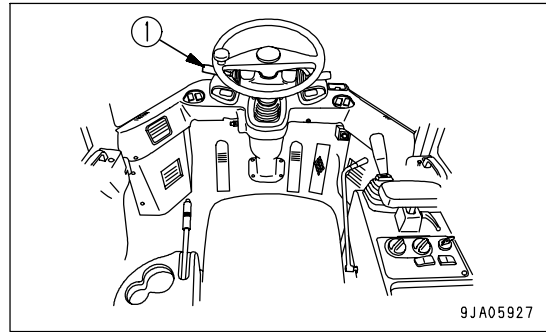

There is no need to stop the machine even when switching between FORWARD and REVERSE.

Place directional lever (1) in the desired position.

Position (a): FORWARD

Position N: NEUTRAL

Position (b): REVERSE

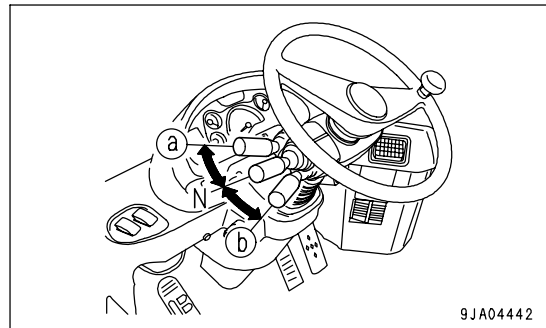

- Check that the backup alarm sounds when the directional lever is set to REVERSE. If the backup alarm does not sound, please contact your Komatsu distributor for repairs.

PRECAUTIONS FOR OPERATION

PERMISSIBLE WATER DEPTH

When working in water or on swampy ground, do not let the water come above the bottom of the axle housing.

After finishing the operation, wash and check the lubricating points.

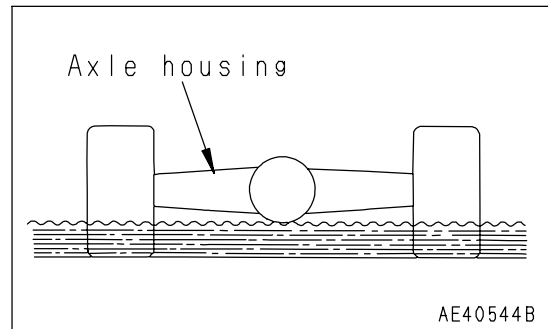

IF WHEEL BRAKE DOES NOT WORK

If the machine is not stopped by depressing the brake pedal, use the parking brake to stop the machine.

NOTICE

If the parking brake has been used as an emergency brake, contact your Komatsu distributor to have the parking brake checked for any abnormality.

PRECAUTIONS WHEN DRIVING UP OR DOWN SLOPES

LOWER THE CENTER OF GRAVITY WHEN TURNING

When turning on slopes, lower the work equipment to lower the center of gravity before turning. It is dangerous to turn the machine suddenly on slopes.

BRAKING ON DOWNHILL SLOPE

If the brake pedal is used frequently when traveling downhill, the brake will overheat and may be damaged. Release the accelerator pedal to make full use of the braking force of the engine when traveling downhill.

Use the right brake pedal for braking.

If the brakes are used excessively, the axle oil temperature caution lamp may light up and the alarm buzzer may sound intermittently. For details of the necessary action to take, see "AXLE OIL TEMPERATURE CAUTION LAMP (PAGE 3-16)" in EXPLANATION OF COMPONENTS.

IF ENGINE STOPS

If the engine stops on a slope, apply the parking brake immediately, and lower the work equipment to the ground and stop the machine. Then put the directional lever in neutral position, and start the engine again.

SECURING MACHINE

Load the machine onto a trailer as follows:

1. Lower the work equipment slowly.
2. Check that the work equipment control lever is at the HOLD position, then set the work equipment lock lever to the LOCK position.

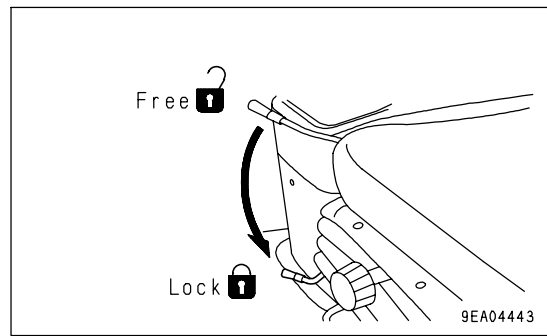

3. Pull parking brake lever to the LOCK position while stepping the brake pedal, then make sure the machine is completely stopped.
4. Turn the starting switch to the OFF position to stop the engine, and pull out the starting switch key.

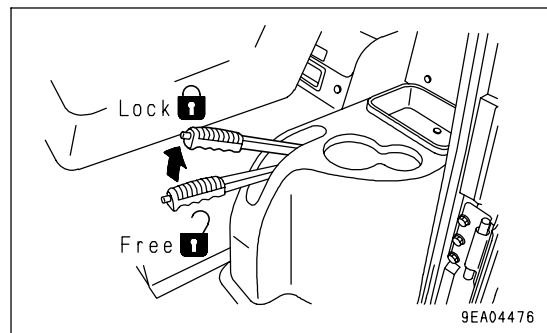

5. Set the frame lock bar to the LOCK position to lock the front frame and rear frame.

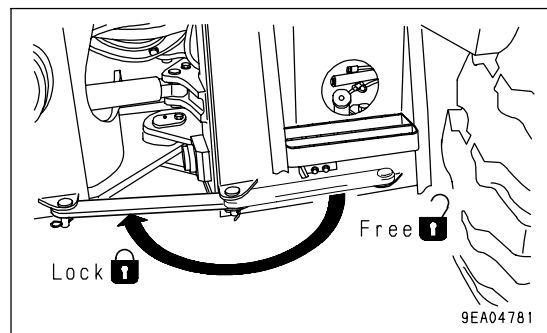

- The towing machine should normally be of the same class as the machine being towed. Check that the towing machine and towed machine both have ample braking power and that the towing machine has ample rimpull to control both machines on the slopes or on the tow road.
- When towing a machine downhill, it may be necessary to connect another machine to the rear of the machine being towed in order to provide ample rimpull and braking power. This makes it possible to prevent the machine from losing control.
- Towing may be carried out under various differing conditions, so it is impossible to determine beforehand the requirements for towing. Towing on flat horizontal roads will require the minimum rimpull, while towing on slopes or on uneven road surfaces will require the maximum rim pull.
- Connect a wire rope to the part indicated with the arrow in the diagram at right.

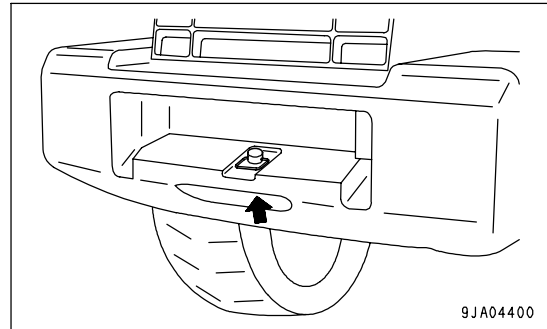

WHEN ENGINE CAN BE USED

- If the transmission and steering wheel can be operated, and the engine is running, it is possible to tow the machine out of mud or to move it for a short distance to the edge of the road.
- The operator should sit on the machine being towed and operate the steering in the direction that the machine is towed.

WHEN ENGINE CANNOT BE USED

When towing a machine with the engine stopped, use the following procedure.

1. The transfer oil does not lubricate the system, so remove the front and rear drive shafts. If necessary, block the tires to prevent the machine from moving.
2. The steering cannot be operated, so remove the steering cylinder.
Even if the brakes are in good condition, the brakes can only be used a limited number of times. There is no change in the operating force for the brake pedal, but the braking force is reduced each time the pedal is depressed.
3. Connect the towing equipment securely. When carrying out towing operations, use two machines of at least the same class as the machine being towed. Connect one machine each to the front and rear of the machine being towed, then remove the blocks from the tires and tow the machine.

EMERGENCY TRAVEL OPERATION

The normal gear shifting operation is carried out by electric signals. If there should be a failure in the electrical system and the machine does not move, please contact your Komatsu distributor to have the machine moved.

NOTICE

Always request your Komatsu distributor to carry out the emergency travel operation.

GUIDES TO MAINTENANCE

Do not perform any inspection and maintenance operation that is not found in this manual.

CHECK SERVICE METER:

Check the service meter reading every day to see if the time has come for any necessary maintenance to be performed.

KOMATSU GENUINE REPLACEMENT PARTS:

Use Komatsu genuine parts specified in the Parts Book as replacement parts.

KOMATSU GENUINE OILS:

For lubrication of the machine, use the Komatsu genuine lubricants. Moreover use oil of the specified viscosity according to the ambient temperature.

ALWAYS USE CLEAN WASHER FLUID:

Use automobile window washer fluid, and be careful not to let any dirt get into it.

ALWAYS USE CLEAN OIL AND GREASE:

Use clean oil and grease. Also, keep the containers of the oil and grease clean. Keep foreign materials away from oil and grease.

CHECKING FOR FOREIGN MATERIALS IN DRAINED OIL AND ON FILTERS:

After oil is changed or filters are replaced, check the old oil and filters for metal particles and foreign materials. If large quantity of metal particles or foreign materials are found, always report to the person in charge, and carry out suitable action.

FUEL STRAINER:

Do not remove the strainer from the filler port when adding fuel.

WELDING INSTRUCTIONS:

- Turn off the engine starting switch.
- Do not apply more than 200 V continuously.
- Connect grounding cable within 1 m (3.3 ft) of the area to be welded. If grounding cable is connected near instruments, connectors, etc., the instruments may malfunction.
- If a seal or bearing happens to come between the part being welded and grounding point, change the grounding point to avoid such parts.
- Do not use the area around the work equipment pins or the hydraulic cylinders as the grounding point.

DO NOT DROP THINGS INSIDE MACHINE:

- When opening inspection windows or the oil filler port of the tank to carry out inspection, be careful not to drop nuts, bolts, or tools inside the machine.
If such things are dropped inside the machine, it may cause damage and/or malfunction of the machine, and will lead to failure. If you drop anything inside the machine, always remove it immediately.
- Do not put unnecessary things in your pockets. Carry only things which are necessary for inspection.

STANDARD TIGHTENING TORQUES FOR BOLTS AND NUTS

TORQUE LIST



If nuts, bolts, or other parts are not tightened to the specified torque, it will cause looseness or damage to the tightened parts, and this will cause failure of the machine or problems with operation.

Always pay careful attention when tightening parts.

Unless otherwise specified, tighten the metric nuts and bolts to the torque shown in the table below. If it is necessary to replace any nut or bolt, always use a Komatsu genuine part of the same size as the part that was replaced.

Thread diameter of bolt (a)(mm)	Width across flats (b)(mm)	Tightening torque					
		Target value			Service limit		
		Nm	kgm	lbft	Nm	kgm	lbft
6	10	13.2	1.35	9.8	11.8-14.7	1.2-1.5	8.7-10.8
8	13	31	3.2	23.1	27-34	2.8-3.5	20.3-25.3
10	17	66	6.7	48.5	59-74	6.0-7.5	43.4-54.2
12	19	113	11.5	83.2	98-123	10.0-12.5	72.3-90.4
14	22	172	17.5	126.6	153-190	15.5-19.5	112.1-141
16	24	260	26.5	191.7	235-285	23.5-29.5	170.0-213.4
18	27	360	37	267.6	320-400	33.0-41.0	238.7-296.6
20	30	510	52.3	378.3	455-565	46.5-58.0	336.3-419.5
22	32	688	70.3	508.5	610-765	62.5-78.0	452.1-564.2
24	36	883	90	651	785-980	80.0-100.0	578.6-723.3
27	41	1295	132.5	958.4	1150-1440	118.0-147.0	853.5-1063.3
30	46	1720	175.0	1265.8	1520-1910	155.0-195.0	1121.1-1410.4
33	50	2210	225.0	1627.4	1960-2450	200.0-250.0	1446.6-1808.3
36	55	2750	280.0	2025.2	2450-3040	250.0-310.0	1808.3-2242.2
39	60	3280	335.0	2423.1	2890-3630	295.0-370.0	2133.7-2676.2

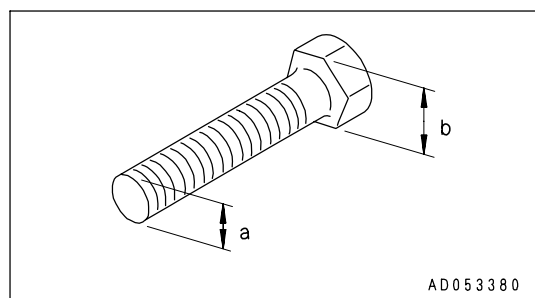

Apply the following table for Hydraulic Hose.

Nominal - No. of threads (a)	Width across flats (b) (mm)	Tightening torque					
		Target value			Permissible range		
		Nm	kgm	lbft	Nm	kgm	lbft
9/16 -18UNF	19	44	4.5	32.5	35 - 63	3.5 - 6.5	25.3 - 47.0
11/16 -16UN	22	74	7.5	54.2	54 - 93	5.5 - 9.5	39.8 - 68.7
13/16 -16UN	27	103	10.5	75.9	84 - 132	8.5 - 13.5	61.5 - 97.6
1 -14UNS	32	157	16.0	115.7	128 - 186	13.0 - 19.0	94.0 - 137.4
13/16 -12UN	36	216	22.0	159.1	177 - 245	18.0 - 25.0	130.2 - 180.8

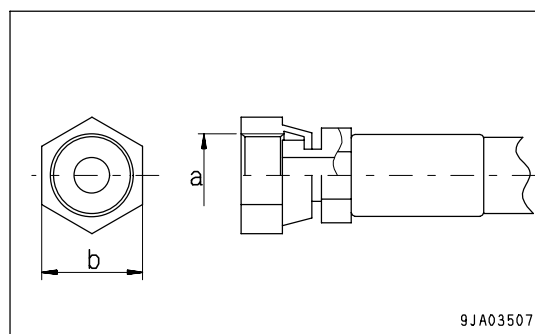

5. Set a container in position to catch the coolant, then open valve (3) under the radiator to drain coolant.
6. After draining the water, close drain valve (3) and fill with city water.
7. When the radiator is full, start the engine, and run it at low idle. Keep the engine running at low idle for 10 minutes until the coolant temperature reaches more than 90°C (194°F).
8. Stop the engine, open drain valves (3), drain the water, then tighten them again.

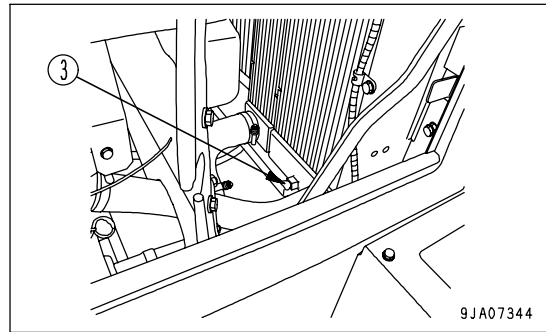

9JA07344

9. After draining the water, clean the cooling system with cleaning agent. For the cleaning method, see the instructions for the cleaning agent.

10. Replace the corrosion resistor, then open 2 valves (1).

For details of the procedure for replacing the corrosion resistor, see "REPLACE CORROSION RESISTOR CARTRIDGE (PAGE 4-57)".

(Machines equipped with corrosion resistor)

11. Add coolant through the water filler port up to the mouth of the port. For details of the COOLANT density, see "COOLANT DENSITY TABLE".
12. To bleed the air from the cooling system, run the engine at low idle for 5 minutes, and for a further 5 minutes at high idle. (When doing this, leave the radiator cap off.)
13. Drain the coolant from sub-tank (4), clean the inside of the sub-tank, then add coolant until the coolant level is between the FULL and LOW marks.
14. Stop the engine, wait for approximately 3 minutes, add coolant up to the mouth of the filler port, and tighten the cap.

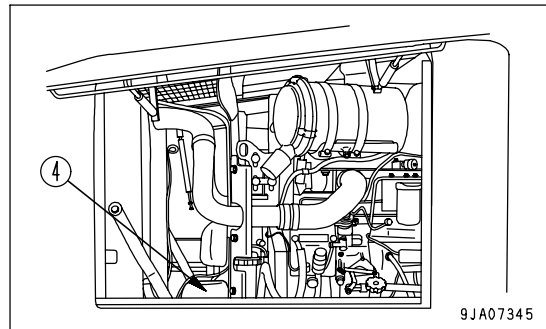

9JA07345

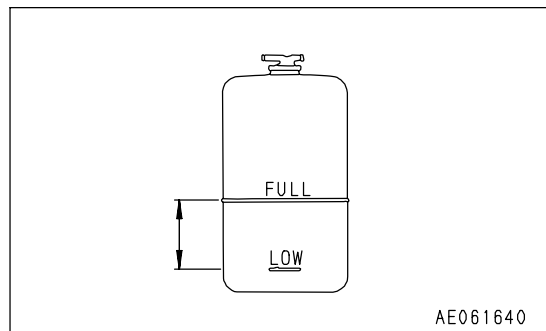

AE061640

CHECK AIR CONDITIONER

(If equipped)

CHECK LEVEL OF REFRIGERANT (GAS)



WARNING

If the refrigerant used in the air conditioner gets into your eyes or on your hands, it may cause loss of sight or frostbite. Do not touch the refrigerant. Never loosen any part of the refrigerant circuit.

Do not bring any flame close to any point where the refrigerant gas is leaking.

Remove cap (1) of the engine hood.

The sight glass of the receiver can be seen through the cap hole.

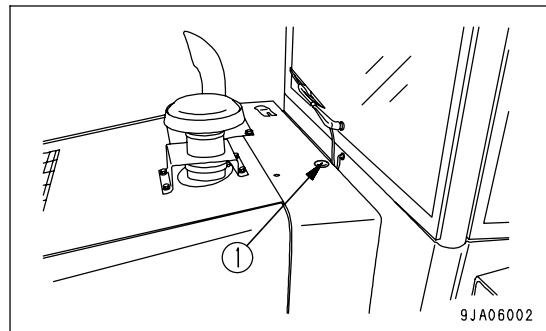

If there is a lack of refrigerant (gas), the cooling performance will be poor. When operating the air conditioner at high speed with the engine at full throttle, use the receiver sight glass (inspection window) to check the condition of the refrigerant gas (R134a) flowing in the refrigerant circuit.

- No bubbles in refrigerant flow: Suitable
- Some bubbles in flow
(bubbles pass continuously): Lack of refrigerant
- Colorless, transparent: No refrigerant

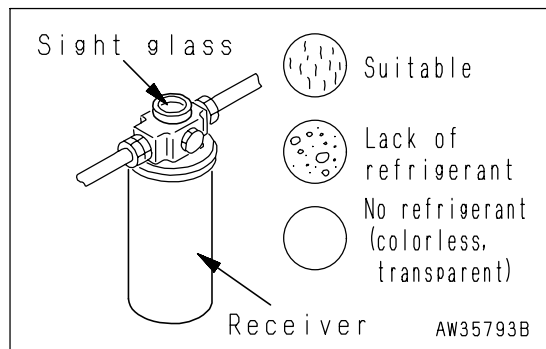

REMARK

When there are bubbles, the refrigerant gas level is low, so contact your Komatsu distributors to have refrigerant added. If the air conditioner is run with the refrigerant gas level low, it will cause damage to the compressor.

OPERATING THE AIR CONDITIONER OFF-SEASON

Even during the off-season, operate the air conditioner for 3 to 5 minutes once a month to maintain the oil film at all parts of the compressor.

EVERY 250 HOURS SERVICE

Maintenance for every 50 and 100 hours service should be carried out at the same time.

CHECK BATTERY ELECTROLYTE LEVEL

Carry out this procedure before operating the machine.



WARNING

- Do not use the battery if the battery electrolyte level is below the LOWER LEVEL line. This will accelerate deterioration of the inside of the battery and reduce the service life of the battery. In addition, it may cause an explosion.
- The battery generates flammable gas and there is danger of explosion, do not bring fire or sparks near the battery.
- Battery electrolyte is dangerous. If it gets in your eyes or on your skin, wash it off with a large amount of water and consult a doctor.
- When adding distilled water to the battery, do not allow the battery electrolyte to go above the UPPER LEVEL line. If the electrolyte level is too high, it may leak and cause damage to the paint surface or corrode other parts.

NOTICE

If there is a fear that the battery water may freeze after refilling with purified water (e.g. commercially available replenishment water for a battery), do the replenishment before the day's work on the next day.

Inspect the battery electrolyte level at least once a month and follow the basic safety procedures given below.

WHEN CHECKING ELECTROLYTE LEVEL FROM SIDE OF BATTERY

If it is possible to check the electrolyte level from the side of the battery, check as follows.

1. Open the cover of the battery box.

There are two battery boxes: One on each side at the rear of the machine.

2. Use a wet cloth to clean the area around the electrolyte level lines and check that the electrolyte level is between the UPPER LEVEL (U.L.) and LOWER LEVEL (L.L.) lines.

If the battery is wiped with a dry cloth, static electricity may cause a fire or explosion.

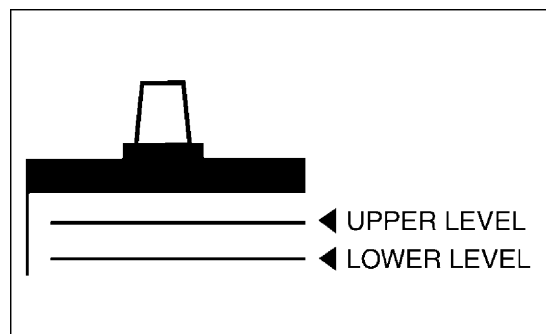

3. If the electrolyte level is below the midway point between the U.L and L.L lines, remove cap (1) and add distilled water to the U.L line.

4. If distilled water has been added to any cell of cap (1), add distilled water also to the other cells.

5. Clean the vents of the battery caps, then close the caps securely.

Keep the top of the battery clean and wipe it with a wet cloth.

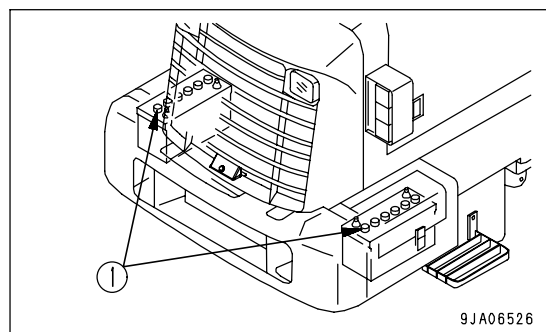

9JA06526

REMARK

If distilled water is added to above the U.L. line, use a syringe to lower the level to the U.L. line. Neutralize the removed fluid with baking soda (sodium bicarbonate), then flush it away with a large amount of water or consult your Komatsu distributor or battery maker.

CLEAN WATER SEPARATOR STRAINER

**WARNING**

- The engine is at high temperature immediately after the machine has been operated. Wait for the engine to cool down before replacing the filter.
- Do not bring fire or sparks near the fuel.

1. Open the engine side cover on the right side of the chassis.
2. Prepare a container to catch the drained fuel and set it under the water separator.
3. Loosen drain valve (1) at the bottom of the water separator and drain the fuel into the container.
4. Loosen ring nut (2), then remove cup (3).
5. Remove strainer (4) from the separator base.
6. Wash the interior of strainer (4) and cup (3) with clean fuel.
7. Check strainer (4) and replace it if it is damaged.
8. Clean the separator base and wash strainer (4), then install the strainer to the separator base.
9. Coat the threaded portion of ring nut (2) thinly with grease.
10. Fill cup (3) with clean fuel, install it to the separator base, then tighten it with ring nut (2).

The specified tightening torque of ring nut (2):

37 to 43 Nm (3.8 to 4.4 kgm , 27.5 to 31.8 lbft)

If the ring is loose, it will cause leakage of fuel, so always tighten it to the specified torque.

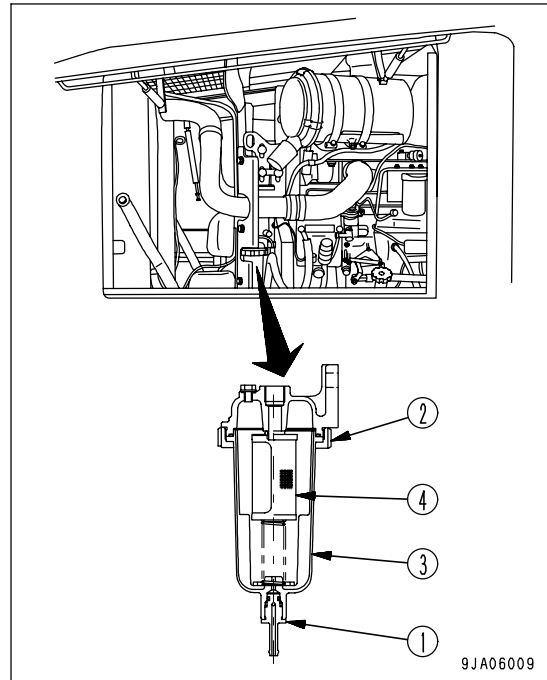

9JA06009

REMARK

Be careful not to lose the O-ring, float, or spring. Be sure to assemble them after washing.

11. After installing filter cup (3), bleed air in the following manner.
12. Loosen air bleed plug (5) of the fuel filter.
13. Loosen the knob of feed pump (6), then pump it up and down until no more bubbles come out with the fuel from air bleed plug (5).
14. After bleeding the air, tighten air bleed plug (5), then push in the knob of priming pump (6) and tighten it.

Tightening torque for air bleed plug: 7.8 to 11.8 Nm (0.8 to 1.2 kgm , 5.8 to 8.7 lbft)

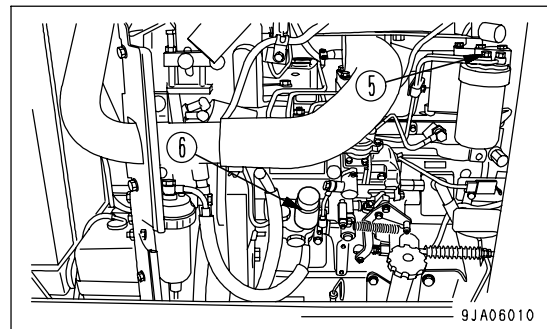

9JA06010

CHECK BRAKE DISC WEAR

**WARNING**

- When checking the brake disc wear, apply the parking brake and secure the front and rear frames with the frame lock bar.
- Make sure that the brake oil temperature is less than 60°C (140°F) before checking the brake wear.
- If the disc is near the wear limit, carry out inspection at shorter intervals, regardless of the specified inspection interval.

When checking the brake disc for wear, there are 4 places (front axle and rear axle, left and right), so use the same procedure to check all 4 places.

- Prepare an inspection gauge.

1. Remove check plug (1).

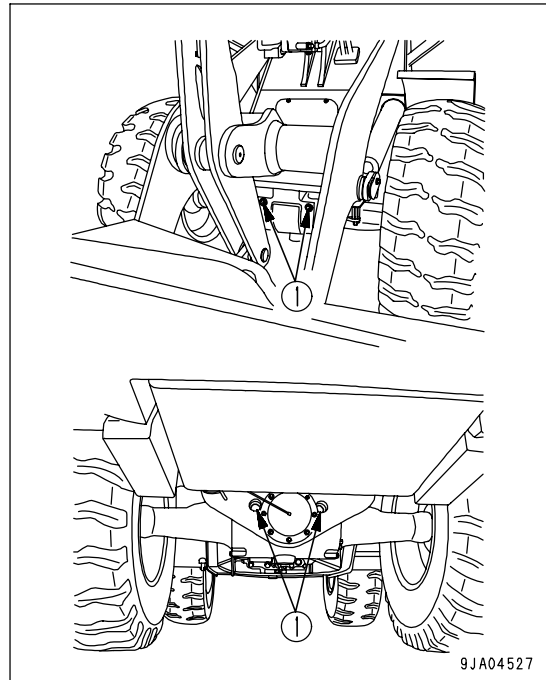

2. With the brake pedal depressed, insert inspection gauge (2) into the tooth portion of piston (3) and plate (4).

3. If the inspection gauge can be inserted into the tooth portion, the disc has reached the wear limit.

Please ask your Komatsu distributor to carry out the replacement.

4. After checking, install check plug (1).

Tightening torque: 127 to 177 Nm (13 to 18 kgm , 94.0 to 130.2 lbft)

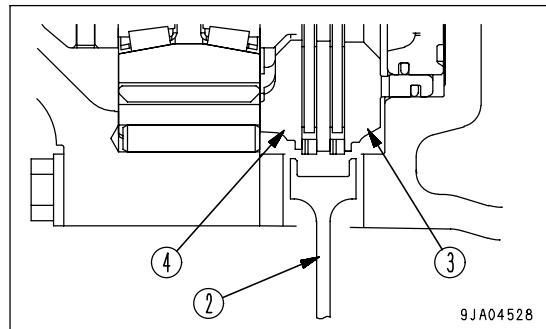

CLICK HERE TO **DOWNLOAD** THE COMPLETE MANUAL

- Thank you very much for reading the preview of the manual.
- You can download the complete manual from: www.heydownloads.com by clicking the link below



- Please note: If there is no response to CLICKING the link, please download this PDF first and then click on it.

CLICK HERE TO **DOWNLOAD** THE COMPLETE MANUAL