

Operation & Maintenance Manual

SK1020-5 turbo

SKID-STEER LOADER

SERIAL NUMBERS SK1020-5 turbo 37CTF00147 and up

This material is proprietary to Komatsu America Corp. and is not to be reproduced, used, or disclosed except in accordance with written authorization from Komatsu America Corp.

It is our policy to improve our products whenever it is possible and practical to do so. We reserve the right to make changes or improvements at any time without incurring any obligation to install such changes on products sold previously.

Due to this continuous program of research and development, revisions may be made to this publication. It is recommended that customers contact their distributor for information on the latest revision.

Copyright 2004 Komatsu
Printed in U.S.A.
Komatsu America Corp.

November 2004

CLICK HERE TO **DOWNLOAD** THE COMPLETE MANUAL

- Thank you very much for reading the preview of the manual.
- You can download the complete manual from: www.heydownloads.com by clicking the link below









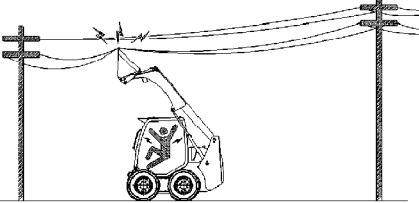
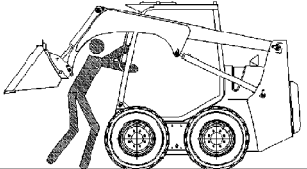

- Please note: If there is no response to CLICKING the link, please download this PDF first and then click on it.

CLICK HERE TO **DOWNLOAD** THE COMPLETE MANUAL

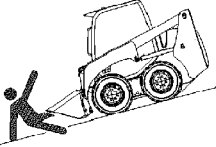
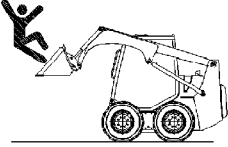
PAGE INTENTIONALLY LEFT BLANK

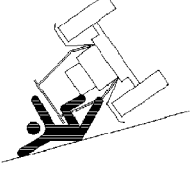







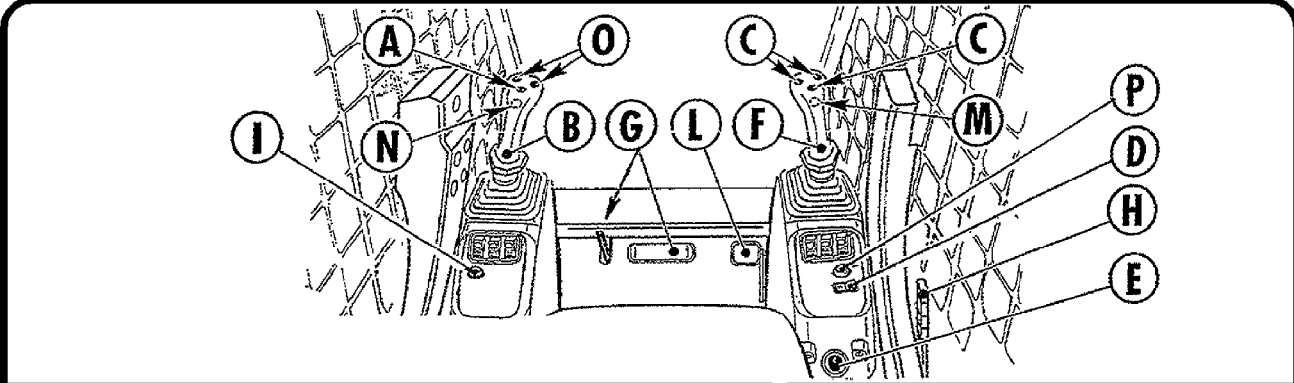

1. Danger, Warning and Caution Decal

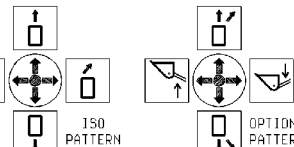
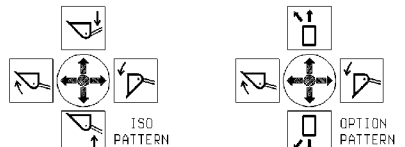
 <h1 style="margin: 0;">DANGER</h1>		 <h1 style="margin: 0;">CAUTION</h1>									
 <p>ELECTROCUTION HAZARD. SERIOUS INJURY OR DEATH CAN OCCUR IF MACHINE OR ATTACHMENT ARE NOT KEPT SAFE DISTANCES AWAY FROM ELECTRICAL LINES.</p> <table border="1" style="width: 100%; border-collapse: collapse;"> <thead> <tr> <th style="text-align: left;">Line voltage</th> <th style="text-align: left;">Safe distance</th> </tr> </thead> <tbody> <tr> <td>6.5 KV</td> <td>At least 10 ft (3 m)</td> </tr> <tr> <td>66.3 KV</td> <td>At least 16 ft (5 m)</td> </tr> <tr> <td>275.3 KV</td> <td>At least 33 ft (10 m)</td> </tr> </tbody> </table>	Line voltage	Safe distance	6.5 KV	At least 10 ft (3 m)	66.3 KV	At least 16 ft (5 m)	275.3 KV	At least 33 ft (10 m)	<h2 style="margin: 0;">KEEP OUT OF THIS AREA</h2>  <h2 style="margin: 0;">DO NOT RISK SERIOUS INJURY OR DEATH</h2>	<p>DO NOT WELD ONTO ROPS STRUCTURE IF ANY DAMAGE IS SUSTAINED TO ROPS STRUCTURE CONTACT YOUR LOCAL KOMATSU DEALER IMMEDIATELY.</p>	
Line voltage	Safe distance										
6.5 KV	At least 10 ft (3 m)										
66.3 KV	At least 16 ft (5 m)										
275.3 KV	At least 33 ft (10 m)										
 <h1 style="margin: 0;">WARNING</h1>											
 <p>BLOCK WHEELS TO PREVENT MACHINE MOVEMENT. DO NOT RISK SERIOUS INJURY OR DEATH.</p>	 <p>DO NOT RISK SERIOUS INJURY OR DEATH.</p>	<p>ALWAYS USE SEAT BELT.</p> 									
 <p>AVOID BEING CRUSHED DO NOT JUMP IF MACHINE TIPS. DO NOT RISK SERIOUS INJURY OR DEATH.</p>		<p>BEFORE MOVING MACHINE OR ITS ATTACHMENTS:</p> <ul style="list-style-type: none"> • HONK HORN TO ALERT PEOPLE NEARBY. • BE SURE NO ONE IS ON OR NEAR MACHINE OR IN AREA OF OPERATION • USE SPOTTER IS VIEW IS OBSTRUCTED. <p>FOLLOW ABOVE INSTRUCTIONS EVEN IF MACHINE IS EQUIPPED WITH TRAVEL ALARM AND MIRRORS.</p> <p>DO NOT RISK SERIOUS INJURY OR DEATH.</p>	 <p>IMPROPER OPERATION AND MAINTENANCE CAN CAUSE SERIOUS INJURY OR DEATH.</p> <p>READ MANUAL AND LABELS BEFORE OPERATING AND MAINTENANCE. FOLLOW INSTRUCTIONS AND WARNING IN MANUAL AND IN LABELS ON MACHINE.</p> <p>KEEP MANUAL IN MACHINE CAB NEAR OPERATOR. CONTACT KOMATSU DISTRIBUTOR FOR A REPLACEMENT MANUAL.</p> <p style="font-size: small;">37C-98-11211</p>								

RKA10890

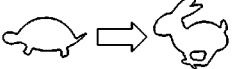
24. Lever Controls



<p>A</p> <ul style="list-style-type: none"> • AVVISATORE ACUSTICO (A RICHIESTA) • WARNING HORN (OPTIONAL) • KLAXON (OPTIONAL) • HUPE (ZUSÄTZE) • AVISADOR ACUSTICO (OPCIONAL) • AVISADOR ACUSTICO (OPTIIONAL) 	<p>G</p> <ul style="list-style-type: none"> • PEDALE COMANDO KIT IDRAULICO AUSILIARIO • AUXILIARY HYDRAULIC KIT CONTROL PEDAL • PEDALE DE COMMANDE DU KIT HYDRAULIQUE AUXILIAIRE • BEDIENTUNGSPEDAL FÜR HYDRAULIKWERZEUG • PEDAL DE MANDO KIT HIDRAULICO AUXILIAR • PEDAL DE COMANDO KIT HIDRAULICO AUXILIAR 
<p>B</p> <ul style="list-style-type: none"> • LEVA COMANDO SX • LEFT CONTROL LEVER 	<p>F</p> <ul style="list-style-type: none"> • LEVA COMANDO DX • RIGHT CONTROL LEVER 
<p>C</p> <ul style="list-style-type: none"> • INTERRUPTORI (A RICHIESTA) • SWITCH (OPTIONAL) • INTERRUPTEUR (OPTIONAL) • SCHALTER (ZUSÄTZE) • INTERRUPTOR (OPCIONAL) • INTERRUPTOR (OPTIIONAL) 	<p>L</p> <ul style="list-style-type: none"> • PEDALE ACCELERATORE (A RICHIESTA) • ACCELERATOR PEDAL (OPTIONAL) • PEDALE DE L'ACCELERATEUR (OPTIONAL) • GASPEDAL (ZUSÄTZE) • PEDAL DEL ACCELERADOR (OPCIONAL) • PEDAL DO ACCELERADOR (OPTIIONAL) 
<p>D</p> <ul style="list-style-type: none"> • COMUTATORE INDICATORI DI DIREZIONE • DIRECTION INDICATOR SWITCH • COMUTEATEUR INDICATEURS DE DIRECTION • RICHTUNGSANZEIGER • INDICADORES DE DIRECCION • INDICADORES DE DIRECCAO 	<p>M</p> <ul style="list-style-type: none"> • COMANDO DISPOSITIVO FLOTTANTE (SE MONTATO) • ARM FLOATING DEVICE CONTROL (IF INSTALLED) • COMMANDE DU DISPOSITIF POUR BRAS FLOTTANT (SI IL EST MONTE') • DRUCKKNOPF SCHWIMMVOORRICHTUNG (FALLS VORHANDEN) • COMANDO DEL DISPOSITIVO FLOTTANTE (SI ESTA' MONTADO) • COMANDO DO DISPOSITIVO FLUTUANTE (SE MONTADO) 
<p>E</p> <ul style="list-style-type: none"> • COMUTATORE DI AVVIAMENTO • STARTING COMMUTATOR • COMUTEATEUR DE MISE EN MARCHÉ • STARTUNTSCHALTER • INTERRUPTOR DE PUESTA EN MARCHA • INTERRUPTOR DE IGNICÃO 	<p>N</p> <ul style="list-style-type: none"> • INTERRUPTORE INCREMENTO VELOCITA' • SPEED INCREASE SWITCH • INTERRUPTEUR D'AugMENTATION VITESSE • SCHALTER FÜR GESCHWINDIGKEITZUNAHME • INTERRUPTOR AUMENTO DE LA VELOCIDAD • INTERRUPTOR DE AUMENTO DA VELOCIDADE 
<p>H</p> <ul style="list-style-type: none"> • LEVA ACCELERATORE A MANO • HAND ACCELERATOR LEVER • LEVIER ACCELERATEUR MANUEL • HANDGASHEBEL • ACCELERADOR DE MÃO • ACCELERADOR MANUAL 	<p>O</p> <ul style="list-style-type: none"> • OPTIONAL INTERRUPT. HIGH FLOW (SE MONTATO) • OPTIONAL HIGH FLOW (IF EQUIPPED) 
<p>I</p> <ul style="list-style-type: none"> • INTERRUPTORE FRENO • SWITCH BRAKE • INTERRUPTEUR FREIN DE STATIONNEMENT • STANDBREMS-SCHALTER • INTERRUPTOR FRENO • INTERRUPTOR DE ESTACIONAMENTO 	<p>P</p> <ul style="list-style-type: none"> • INTERRUPTORE INSERIMENTO EMERGENZA • EMERGENCY SWITCH • INTERRUPTEUR D'ENCLenchement URGENCE • NOTSCHALTER • INTERRUPTOR DE EMERGENCIA • INTERRUPTOR DE ACTIVAÇÃO DE EMERGENCIA 

32A-98-11251

RKA10940

2.2 GENERAL PRECAUTIONS

2.2.1 GENERAL SAFETY RULES

- Only trained and authorized personnel can use the machine and perform maintenance operations.
- When using the machine or performing maintenance operations, follow all the safety rules, precautions and instructions.
- When working with other operators or when the work site is often occupied by other operators, make sure that everyone knows and understands all the agreed signals and, in any case, that everyone works in such a way as to be able to see the machine and to be visible to the operator.

2.2.2 SAFETY DEVICES AND GUARDS

- Make sure that all the guards and covers are in the correct position. Have guards and covers changed or repaired if damaged. Neither use the machine without guards, nor remove the guards when the engine is running.
- Always use the proper safety devices to lock the machine when parking and remember to fasten the seat belt.
- For the safety devices, see "3.1 SAFETY LOCKS".
- For the seat belt, see "3.5.6 SEAT BELT".
- Do not remove the safety devices and always keep them in good operating conditions.
- Improper use of the safety devices may lead to serious injuries or even death.

2.2.3 CLOTHING AND PERSONAL PROTECTION ITEMS

- Do not wear large or loose clothes, rings and watches and do not approach the machine with loose long hair, since they can get entangled in the moving parts of the machine and cause serious injuries and damage.
Avoid also wearing clothes dirty with oil or fuel, since they are flammable.
- Wear a hard hat, goggles, safety shoes, mask, gloves and headphones when operating the machine or performing maintenance operations.
- Always wear safety goggles, a hard hat and heavy gloves if your job involves scattering metal chips or minute materials; these precautions are particularly useful when driving the equipment connection pins with a hammer and when blowing compressed air into the air filter and the radiator to clean them.
During these operations, make also sure that no one is standing or working near the machine without the necessary protections.
- When working for 8 hours with a noise level exceeding 90 dBA, it is necessary to use headphones or ear plugs and to be particularly careful, especially at the end of the work shift.

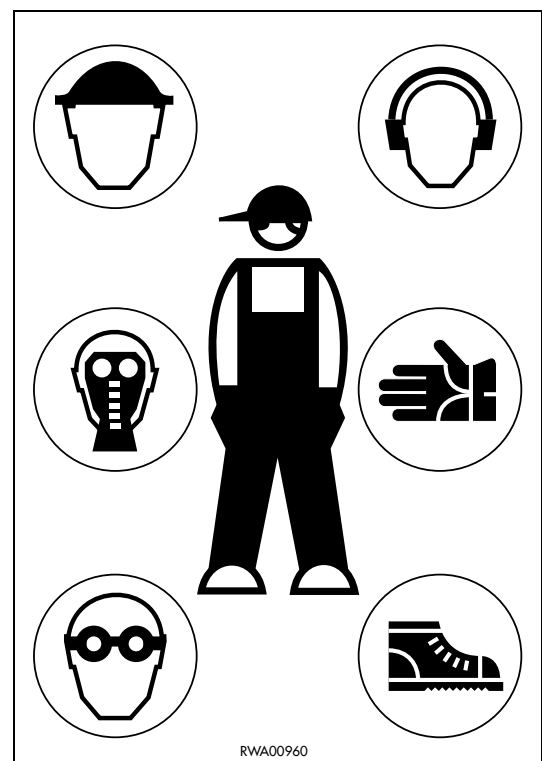

PRECAUTIONS TO BE TAKEN WHEN WORKING

- Travel up or down slopes with the heaviest part of the loader facing the top of the slope.
- Do not travel on wet grass or thick layers of leaves: if the machine moves obliquely in these conditions, it may slip.
- Before carrying out any operation on a slope, always check the functionality of the parking brake.
- Do not go down slopes at high speed; you may lose control of the machine and cause serious damage and even death.
- Do not move on slopes with inclination exceeding 15°, since the machine may overturn.
- When the fuel level indicator reaches the red reserve area during work on a slope, immediately provide for refueling; due to the inclination of the machine, the engine may suck in air and stop suddenly, which represents a grave risk for the safety of the operator and of the persons before the machine.
- If the engine should stop all of a sudden, immediately lower the bucket to the ground and apply the parking brake.

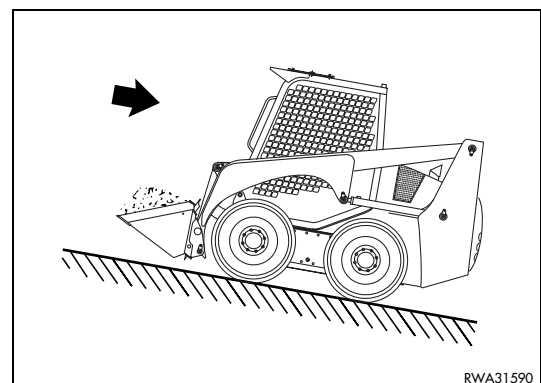
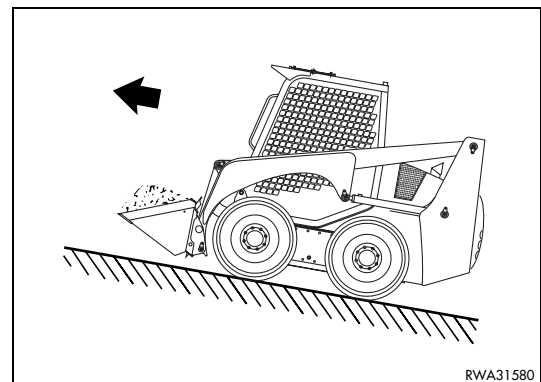
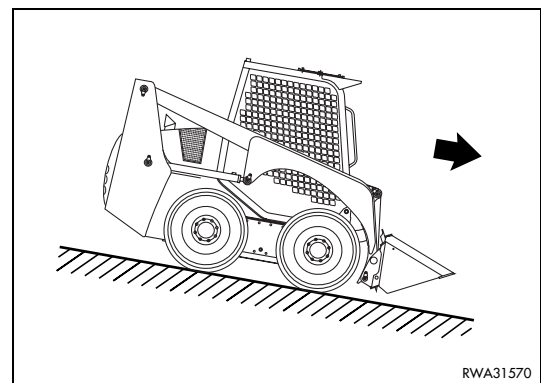
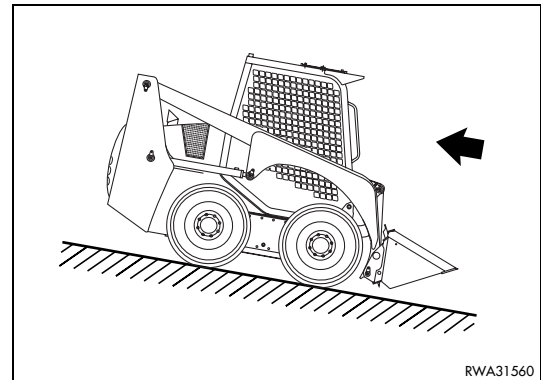

2.8.7 USE OF THE ENGINE DURING MAINTENANCE

- During maintenance operations, run the engine only when indispensable. If it is necessary to have the engine running (for example, to wash the cooling circuit or to check the functionality of the alternator), an operator should constantly remain in the cab, in order to be able to stop the engine whenever this is required.
- During maintenance operations with running engine, never disengage the safety locks of the controls from the normal LOCK position.
Service personnel must not move any control lever.
- When carrying out maintenance operations, do not touch the moving parts of the machine and avoid wearing large and loose clothes.

2.8.8 PERIODICAL CHANGE OF THE PARTS THAT ARE CRITICAL FOR SAFETY

- Periodically change the following parts, which are important to prevent fires.
Fuel supply system: fuel delivery and return pipes.
Hydraulic system: main delivery pipes of the hydraulic pump.
- Even if they seem to be in good conditions, these components must be periodically changed with new ones. In fact, these components tend to deteriorate over time.
- If one of these parts is defective, change or repair it even if the recommended change interval has not elapsed yet (see "4.6 PERIODICAL CHANGE OF THE COMPONENTS CONNECTED WITH SAFETY").

2.8.9 STOP THE ENGINE BEFORE CARRYING OUT ANY MAINTENANCE OPERATION OR INSPECTION

- Stop the machine only on firm and level ground and stop the engine before carrying out any maintenance operation or inspection.
- If the engine must be running during a maintenance operation, shift the safety bars to the LOCK position and carry out the maintenance operation with the help of another person; one operator must remain on the machine and the words and signs to be used must be agreed upon in advance.
- The person who carries out the maintenance operations must be very careful not to touch any moving part of the engine.

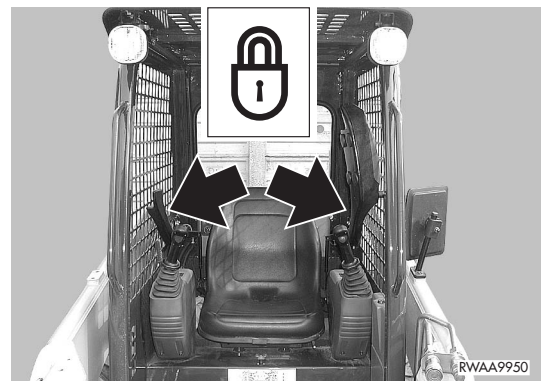
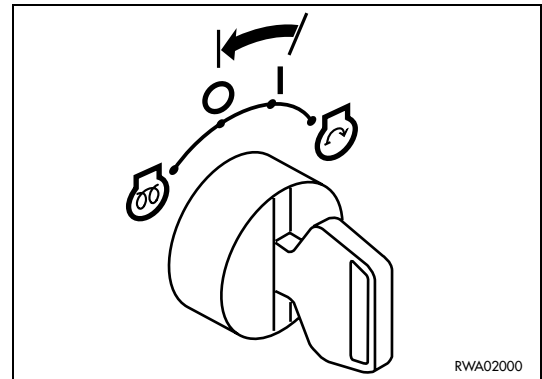

3.1.2 BACKHOE LOCKS (if installed)

⚠ DANGER

- When traveling on roads, always position the backhoe following the longitudinal axis of the vehicle, apply the safety locks and lock the equipment control by shifting the safety device lever to the lock position.

The safety locks of the backhoe are necessary for circulation on roads and they must be applied by proceeding as follows.

- After folding the bucket completely, engage the retainer (1) between the boom and the arm, the pin (2) connecting the boom with the revolving support, the central pin (3) locking the sliding plate on the frame, raise the stabilizers completely and couple the relevant safety chains (4).

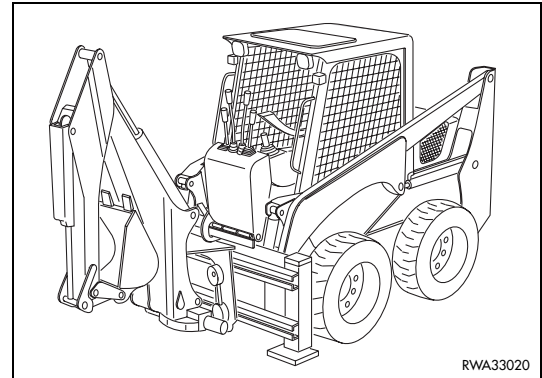

RWA33020

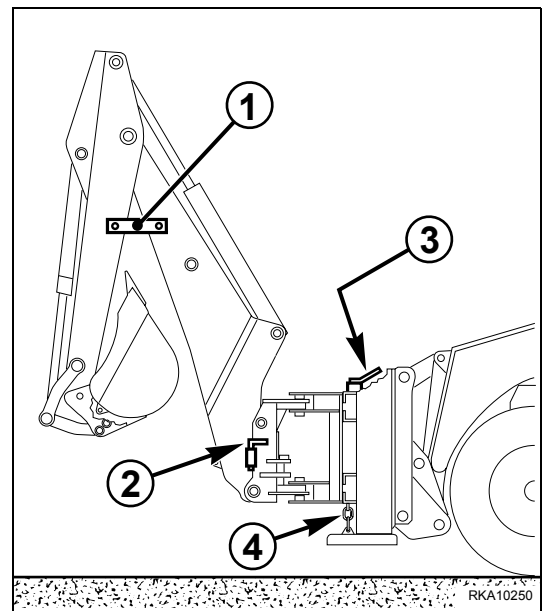

RKA10250

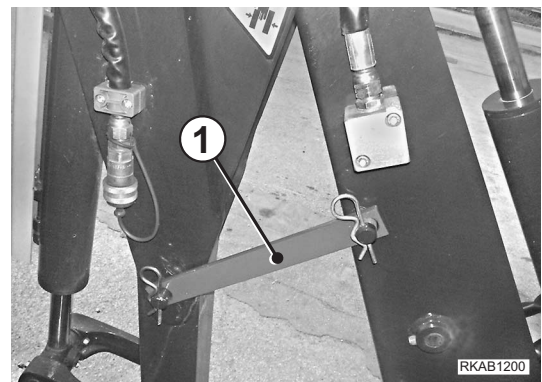

RKAB1200

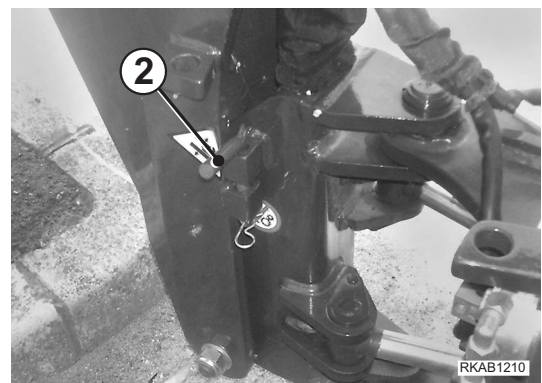

RKAB1210

2 - PREHEATING INDICATOR LIGHT

This indicator light comes on when the ignition key is turned to position «» to start the engine at low temperatures and goes out automatically after approximately 13 seconds (see "3.6.2.2 STARTING WITH COLD ENGINE OR IN COLD CLIMATES").

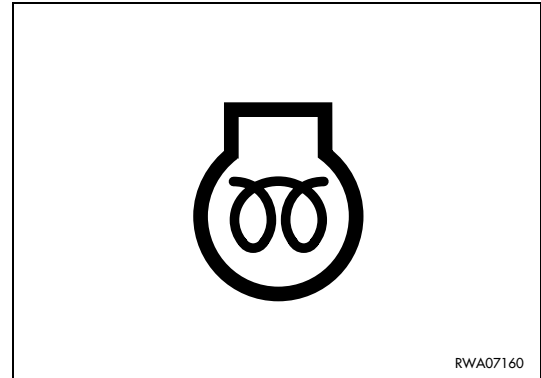

3 - ENGINE OIL PRESSURE INDICATOR LIGHT

This indicator light comes on and activates the acoustic alarm with engine at rest when the starting circuit is energized and goes out as soon as the engine lubrication circuit is pressurized.

If this indicator light remains on or comes on with the engine running, stop the machine immediately and try to locate the trouble.

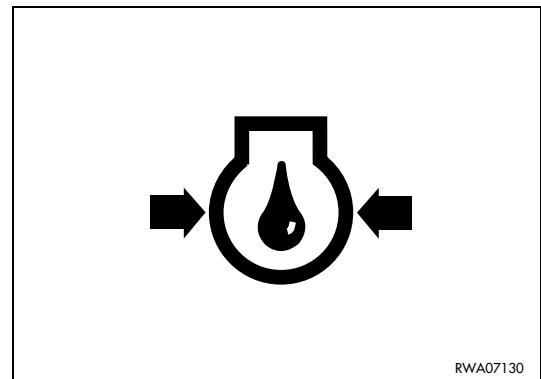

4 - AIR CLEANER CLOGGING INDICATOR LIGHT

This indicator light comes on when the engine air filter needs cleaning.

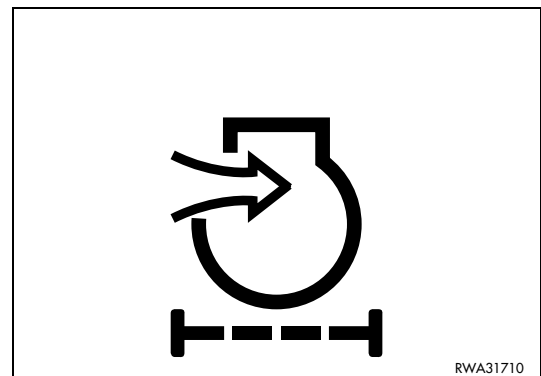

5 - HYDRAULIC OIL FILTER CLOGGING INDICATOR LIGHT

This indicator light comes on when the hydraulic circuit filter needs replacing.

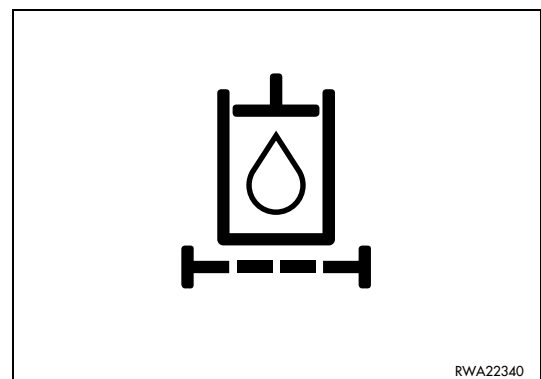

2 - 12 VOLT ELECTRICAL OUTLET

An electric outlet is positioned on the right side of the cab inner wall for the connection of a lighting device for routine and maintenance operations.

It is a two-pole outlet and is in compliance with the ISO 4165-1979 standard.

Power supply 12 V.

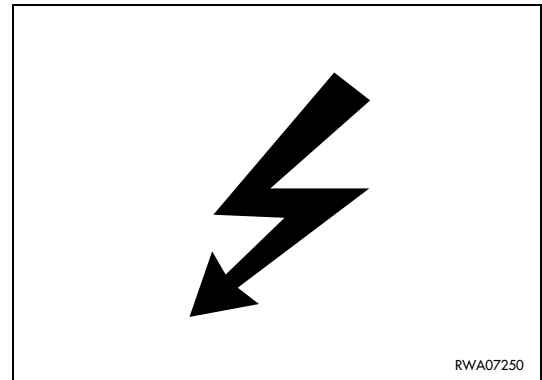

3 - MASTER ELECTRICAL DISCONNECT SWITCH (if provided)

This is a removable lever-type switch positioned near the battery; to reach it, it is necessary to open the engine hood (see "3.5.1 ENGINE HOOD").

The current transmitted by the battery to the electric system of the machine can be interrupted by rotating the switch clockwise (position B).

Always rotate the switch to "position B" if it is necessary to work on the battery or the electric system, or if electric welds must be carried out on the machine.

The electric contact can be restored by rotating the switch anticlockwise (position A).

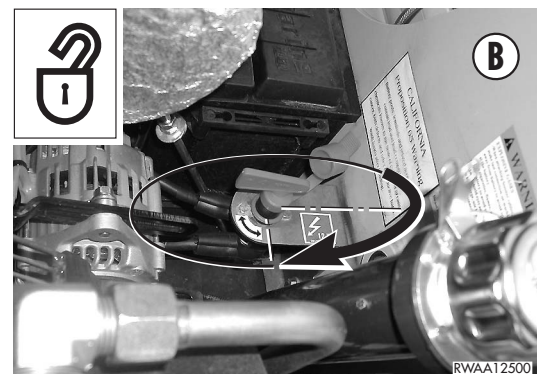
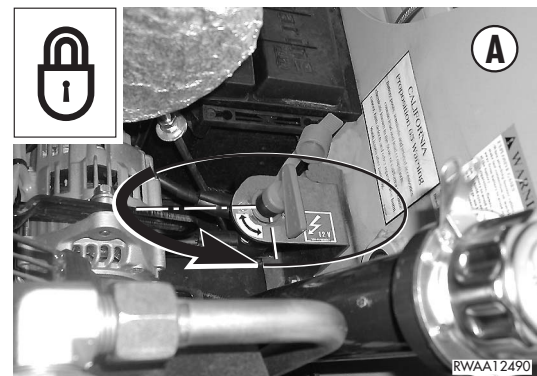

3 - RIGHT PPC CONTROL LEVER (RIGHT WHEEL TRAVEL, STEERING AND BUCKET CONTROL)

WARNING

- Before carrying out any maneuver with this lever, the operator must be seated in the work position with fastened seat belt; before every maneuver the operator must take all the precautions indicated in "3.6.5 HOW TO MOVE THE MACHINE (ISO PATTERN CONTROL SYSTEM)" and "3.13 USING THE WORK EQUIPMENT".
- Before moving, make sure that the safety bars are in the horizontal (unlocked) position and the parking brake is disengaged.
- When traveling on roads, always lock the equipment control (see "3.3.5 pos. 8 - EQUIPMENT CONTROL LOCKING LEVER (IF INSTALLED)").
- When traveling on roads, make sure that all the safety devices have been engaged.
- Before leaving the work position, lower the equipment to the ground and lock the safety bars (vertical position), then stop the engine.
- Failure to comply with these rules may lead to serious accidents.

The right PPC control lever (3) serves to control the forward and reverse movements, the steering of the machine to the left, the bucking curling and dumping function, according to the movements indicated in the diagram below.

IMPORTANT

- To move the machine forward or backward, shift the control levers (2) and (3) at the same time and in the same direction.

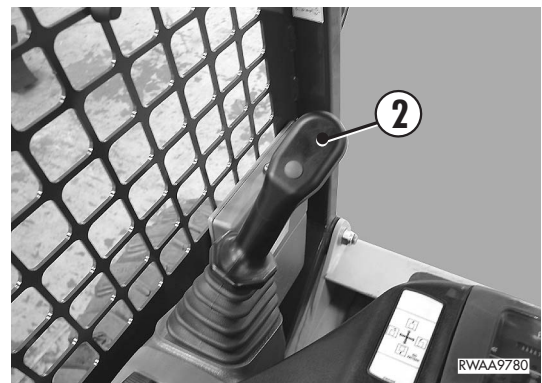

INSTRUMENTS AND CONTROLS

The lever (2) controlling the pattern change valve has two positions:

A - Position for the ISO PATTERN CONTROL SYSTEM

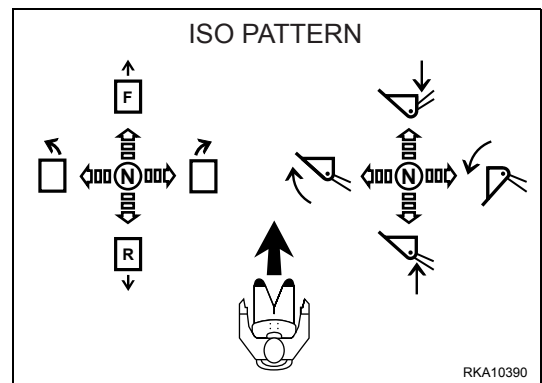
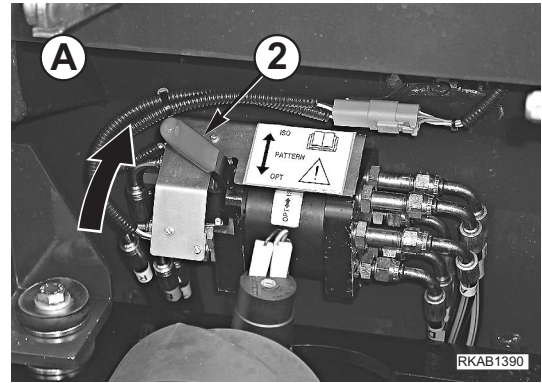

B - Position for the OPTION PATTERN CONTROL SYSTEM

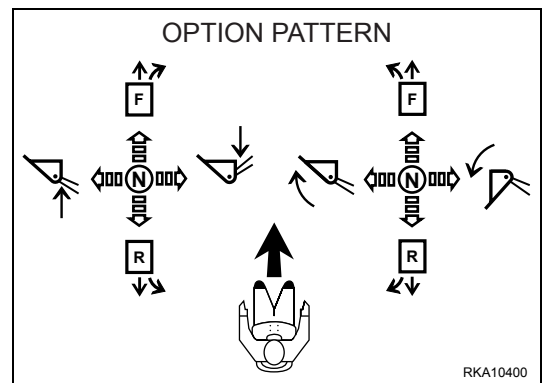
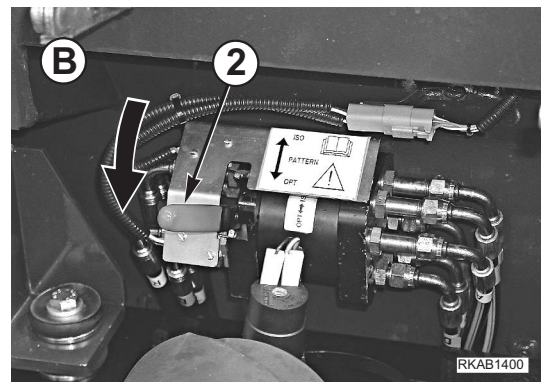

CLICK HERE TO **DOWNLOAD** THE COMPLETE MANUAL

- Thank you very much for reading the preview of the manual.
- You can download the complete manual from: www.heydownloads.com by clicking the link below



- Please note: If there is no response to CLICKING the link, please download this PDF first and then click on it.

CLICK HERE TO **DOWNLOAD** THE COMPLETE MANUAL

3.5.3.1 TILTING THE CAB

WARNING

- Tilt the cab only with the machine parked on a firm and level surface and with arm lowered to the ground complete with bucket or any other optional equipment. Make sure that the surface on which the machine is parked is not slippery.
- Before tilting the cab, make sure that the engine hood is open.
- The cab must be tilted or lowered by two persons, one per side, and it is important to make sure that the handles and hold points are not dirty with oil or grease.
- After tilting the cab, always engage the safety split pin of the cab overturning protection lock.
- Do not carry out any operation on the machine if the safety split pin of the cab overturning protection lock is not engaged.
- Always tighten the cab fastening screws to the torque indicated in "4.4.2 SPECIFIC DRIVING TORQUES".

To carry out some maintenance or routine operations it is necessary to tilt the cab, an operation that must be carried out by two persons according to the prescribed procedure.

- 1 - Stop the machine on firm and level ground.
- 2 - Lower the equipment to the ground.
- 3 - Apply the parking brake and lock the controls by lifting the safety bars.
- 4 - Stop the engine as indicated in "3.8 STOPPING THE ENGINE".
- 5 - Open the engine hood (see "3.5.1 ENGINE HOOD") and remove the rear screws (1) that fasten the cab. Use a 19 mm hexagon wrench.
- 6 - With the help of another person, tilt the rear part of the cab using the appropriate handles and overturn it forwards until it stops.
- 7 - Engage the safety split pin (2) of the cab overturning protection lock (3).

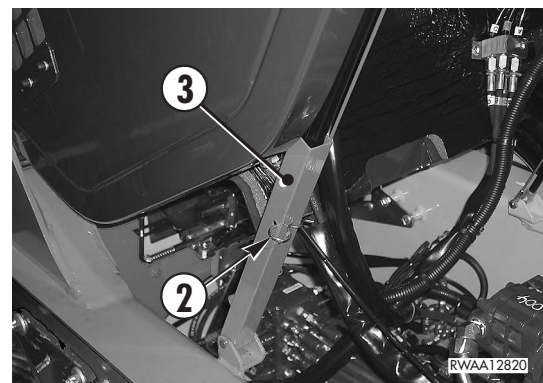
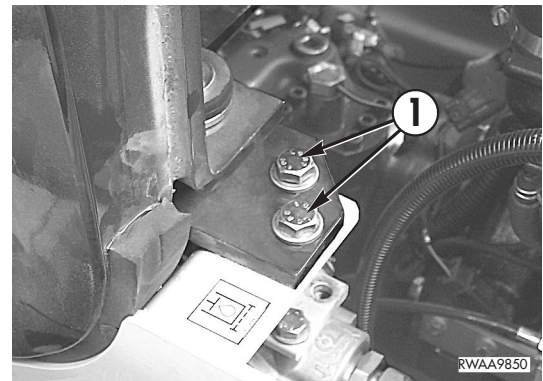

USE OF THE MACHINE

Before moving the machine, check the instruments, warm up the engine and the hydraulic system oil, make sure that the safety device of the controls is released (safety bars down) and the bucket is curled; the equipment control lever must be in neutral position.

Release the parking brake.

- 1 - Pull the hand accelerator lever and set the engine running at idling speed.

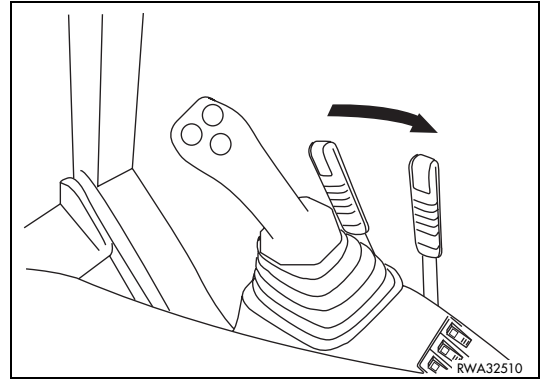

- 2 - Operate the lever (1), shifting it forward to make the machine advance or backward to make it move in reverse.

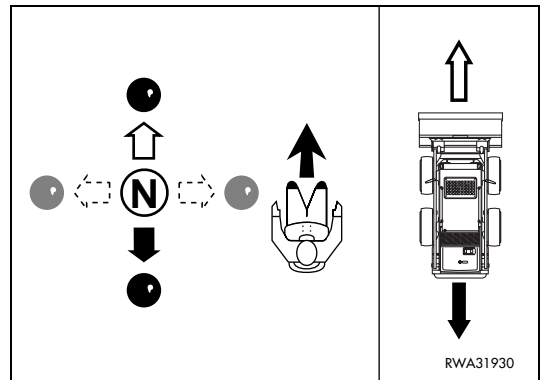
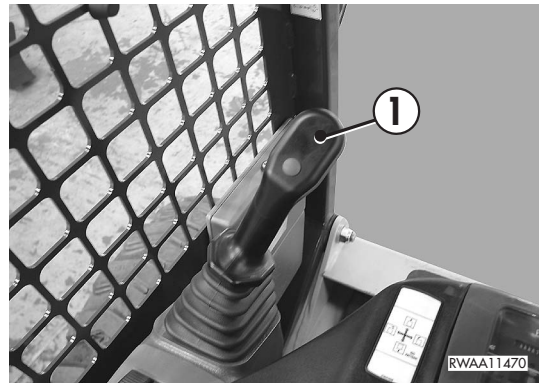

3.7.2 PARKING ON SLOPES

WARNING

- The movement of the machine when the operator is not board may cause serious accidents and even death; to prevent this, carry out the operations described below.
- Park on slopes only when it is absolutely necessary.
- Park only with the bucket directed downwards.

- 1 - Park the machine with the bucket directed downwards and resting against an obstacle.
If this is not possible due to the absence of natural obstacle rotate the bucket forward and thrust its teeth into the ground.
- 2 - Lock the equipment and travel hydraulic control by shift the safety bars to the vertical position (see "3.3.5 pos. SAFETY BARS").
- 3 - Engage the safety guard to lock the optional equipment control pedal.
- 4 - Apply the parking brake.
- 5 - Stop the engine following the procedure indicated in paragraph "3.8 STOPPING THE ENGINE".
- 6 - Remove the ignition key.
- 7 - Leave the cab using the handles and the footboards.
- 8 - Position safety wedges under the wheels.
- 9 - Refuel, taking the necessary precautions.

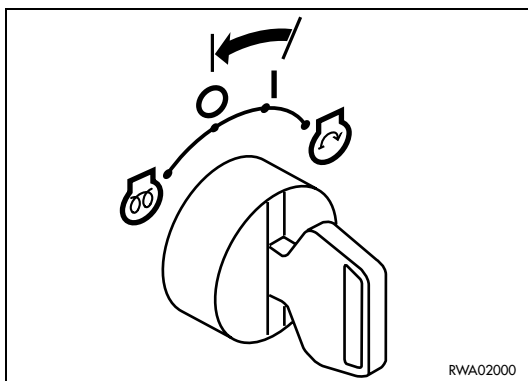
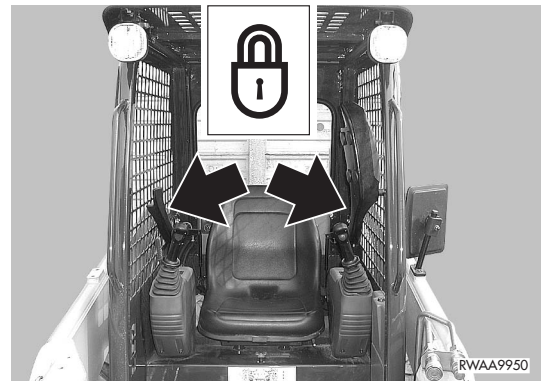
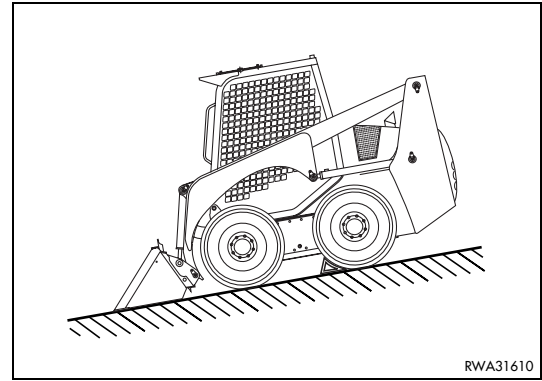

3.13.3 LOADING MATERIAL ON HEAPS AND ON LEVEL SURFACES

The efficiency of the bucket depends on how the operator begins to load; keep to the following rules:

- 1 - Start moving with the arm completely lowered and direct the bucket toward the base of the heap.
- 2 - While the material on top of the heap falls into the bucket, gradually raise the arm and at the same time fold the bucket until reaching the end of stroke.

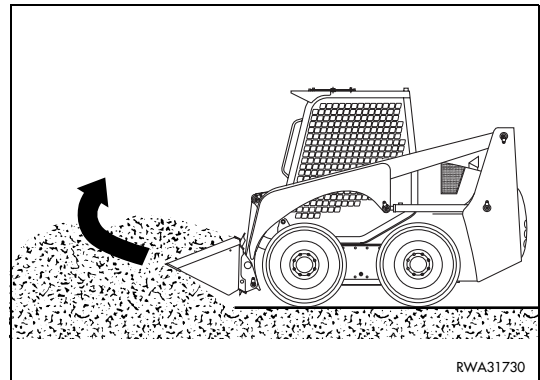
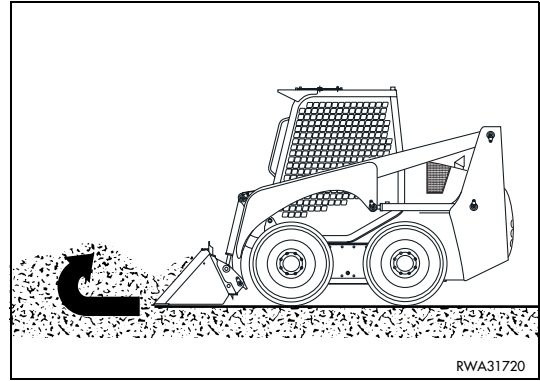

- 3 - Invert the machine motion and dump the bucket on to the truck.

IMPORTANT

- Start loading the truck from the cab side and, if the material is sufficiently homogeneous, dump from the maximum height in order to increase the compactness of the material and its distribution on the loading surface.

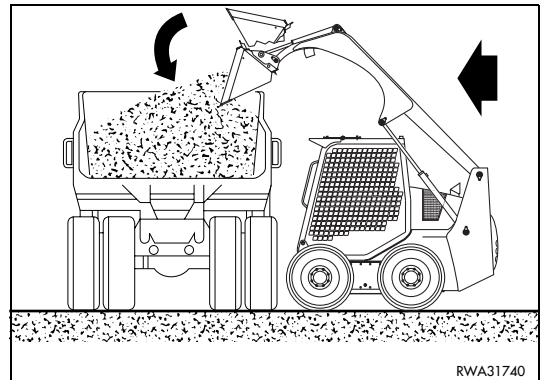

- 4 - After removing the heap completely, incline the bucket forward, lower the arm until raising the front wheels slightly and, proceeding in reverse, level the ground distributing the material uniformly. Repeat the operation reducing the inclination of the bucket for the finishing work.

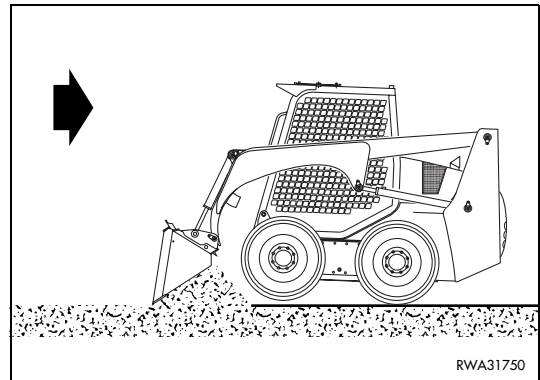

3.15 TROUBLESHOOTING

3.15.1 HOW TO REMOVE THE MACHINE

⚠ DANGER

- When removing the machine, use a wire rope suitable for the weight of the machine to be removed.

If the machine gets stuck in mud and cannot get out using only its motive power, or in case of breakdown, use a wire rope as shown in the figure on the right.

IMPORTANT

- In case of failure of the hydraulic circuit, before recovering the machine release the negative brake installed on the rear axle (see "4.8.1.d RELEASING THE PARKING BRAKE").

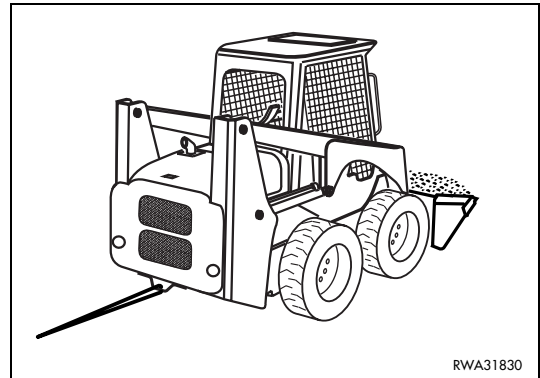

3.15.2 IF THE FUEL HAS BEEN COMPLETELY DEPLETED

Before starting the engine when the fuel has been completely depleted and therefore air has entered the fuel supply circuit, it is necessary to bleed the fuel supply circuit.

For the necessary operations, see "4.8.8 MAINTENANCE EVERY 500 HOURS OF OPERATION".

4.2 MAINTENANCE NOTES

- Use only Komatsu genuine spare parts.
- Do not mix different types of oil.
- Unless specified otherwise, the oils and the coolant used by Komatsu to fill the tanks before the delivery of the machine are the following:

ITEM	SPECIFICATIONS
• Engine oil	SAE 10W-30 API classification CD
• Hydraulic system and hydrostatic transmission oil	SAE 10W API classification CD
• Biodegradable hydraulic system oil (only for machines filled with synthetic biodegradable oil type HEES not of plant origin)	SHELL NATURELLE HFX-32
• Final transmission oil	SAE 10W-30 API classification CD
• Fuel	Ambient temperature above -10°C (14°F): ASTM D975 no. 2 diesel oil
	Ambient temperature below -10°C (14°F): ASTM D975 no. 1 diesel oil
• Radiator coolant	Permanent, ethylene glycol-based antifreeze, with corrosion inhibitor for protection up to -36°C (-33°F).

4.2.1 NOTES REGARDING THE ENGINE

4.2.1.1 ENGINE OIL

- The engine oil must be selected very carefully, since it lubricates the engine, which is the machine's heart; the main maintenance operations required for the engine oil are the following:
 - 1 - daily check of the oil level;
 - 2 - check of the oil pollution degree;
 - 3 - periodical change.

4.2.1.2 COOLANT

- The coolant serves to keep the engine at the correct temperature and therefore to ensure optimal operating conditions; check the coolant level in the expansion tank daily and top up if necessary.
- The coolant containing antifreeze is flammable; do not use naked flames near the coolant and do not smoke while topping up.
- Use only permanent ethylene glycol-based antifreeze with the addition of anticorrosion and antifoam products. The antifreeze-water ratio must be 50% (50% antifreeze and 50% water).
- The use of permanent antifreeze requires only the routine change. It is not necessary to wash the cooling circuit.
- Use drinkable water and in any case soft water.
- Do not use corrosion inhibitors containing soluble oil, since they damage the rubber couplings.
- The required standards for permanent antifreeze are the following: SAE-J1034 and FEDERAL STANDARD O-A-548D.
In case of doubt regarding the compliance of the antifreeze used with the standards, contact your Komatsu Distributor and ask for precise information.

4.5 LUBRICATION

4.5.1 LUBRICATION DIAGRAM

IMPORTANT

- For the lubrication procedures for the single points, see "4.7 MAINTENANCE PLAN".
- The type of lubricant to be used is indicated in the lubricant table (see "4.3 FUEL, COOLANT AND LUBRICANTS").

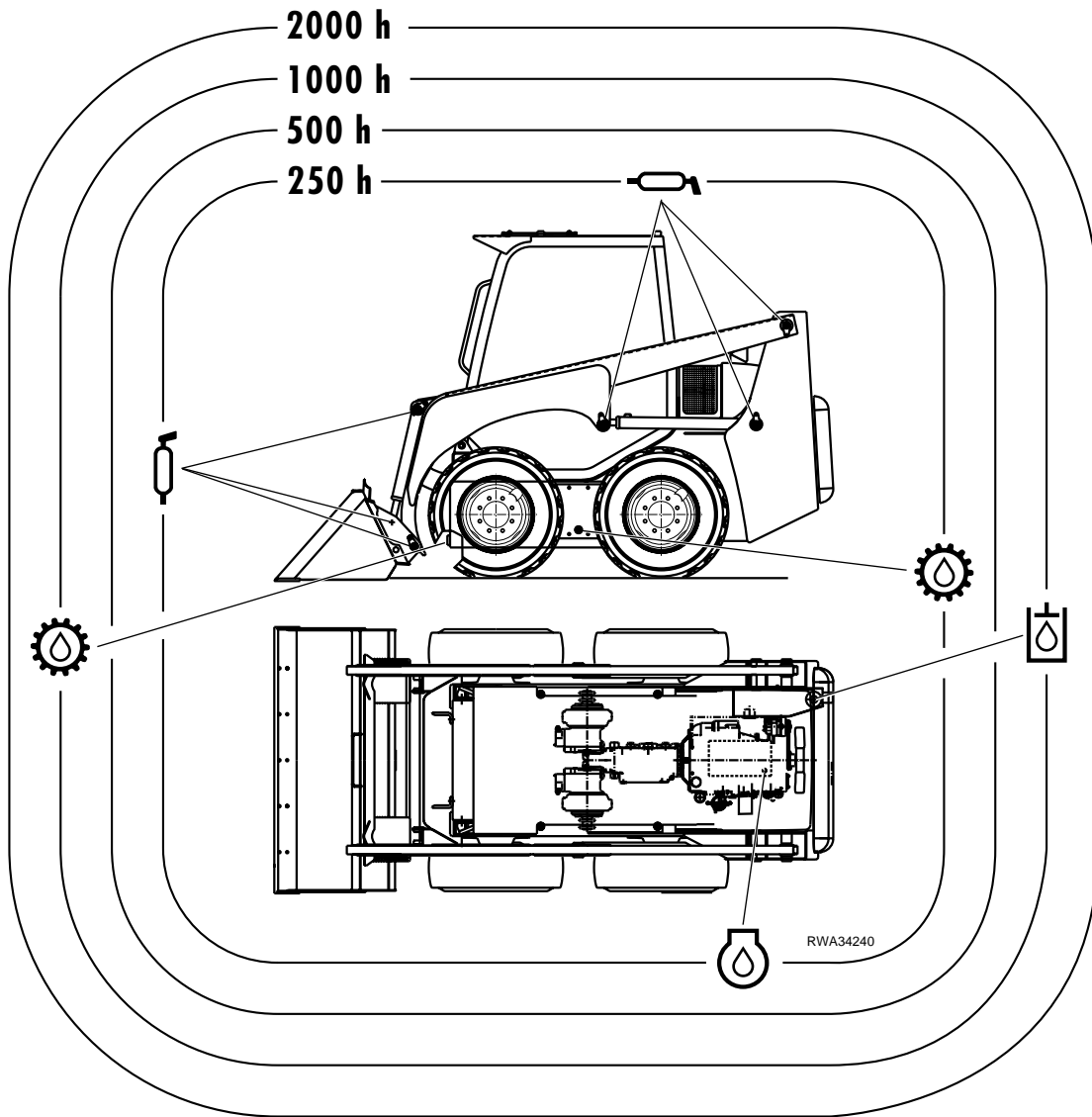

Engine oil



Hydraulic oil



Transmission oil



Grease

4.8 MAINTENANCE PROCEDURE

4.8.1 WHEN REQUIRED

4.8.1.a CHECKING, CLEANING OR CHANGING THE AIR CLEANER CARTRIDGE

⚠ WARNING

- Remove the air cleaner only after stopping the engine and do not start the engine if the air cleaner is open.
- Always wear goggles while cleaning the filter.

IMPORTANT

- The air filtering system comprises a primary filtering element with great capacity and a secondary cartridge that provides additional safety protection. The primary element can be cleaned with compressed air, while the safety cartridge must only be changed.
- The filtering element must be cleaned when the clogging indicator light (A) positioned on the instrument panel blinks or comes on completely. In any case, check whether the cartridge is clogged every 50 hours of operation.
- The filtering element must be cleaned even when the need for cleaning is signalled by the clogging indicator.

The air cleaner can be reached after lifting the engine hood (see "3.5.1 ENGINE HOOD" and opening the rear panel (see "3.5.2 REAR PANEL").

To clean the primary element, proceed as follows:

- 1 - Remove the couplings (1) and remove the clogging filter cover (2).
- 2 - Extract the main filtering element (3).
- 3 - Slightly strike the element on the palm of your hand to eliminate the dust and blow compressed air on the inner surface, keeping the air jet at a distance of approximately 15 cm (5.9 in) and making sure that the pressure does not exceed 4-5 bars (58-73 psi).
- 4 - Carefully clean the filter casing (4), taking care to avoid the introduction of foreign matters in the suction duct and reassemble the unit making sure that the ejector is positioned vertically and at the bottom.

IMPORTANT

- If the clogging indicator light comes on after the engine has started, it is necessary to change the primary filtering element and the safety cartridge.
- Change the primary filtering element after 5 cleaning operations or after one year. The safety cartridge must always be changed together with the primary filtering element.

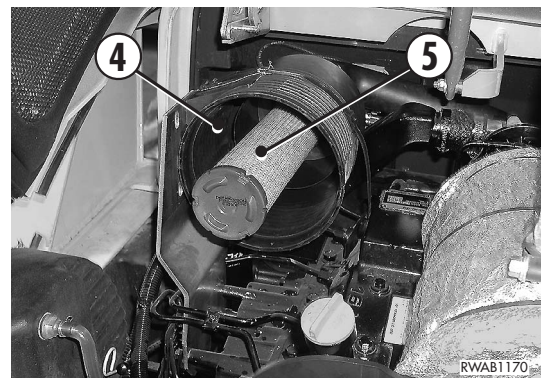
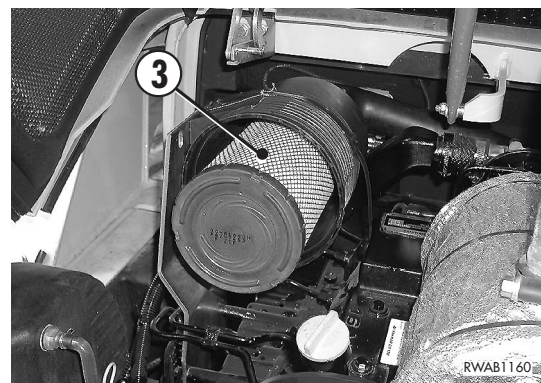
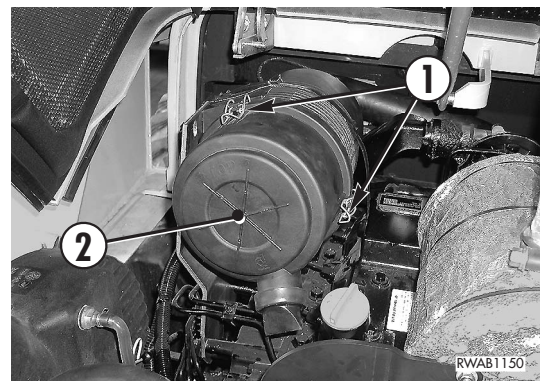
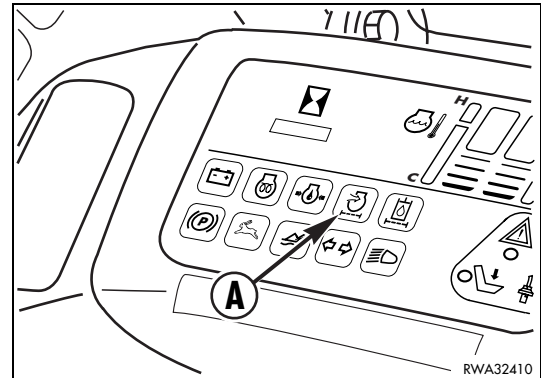

4.8.3 MAINTENANCE AFTER THE FIRST 50 HOURS OF OPERATION

These maintenance operations must be carried out after the first 50 hours of operation, together with those to be carried out "EVERY 50 HOURS".

- CHECK THE GEARING CHAIN TENSION
- CHECK THE TIGHTENING OF THE WHEEL FASTENING NUTS
- HYDRAULIC OIL DRAIN FILTER (only for machines filled with biodegradable oil)

For details on the various maintenance operations, see sections "4.8.6 MAINTENANCE EVERY 250 HOURS OF OPERATION" and "4.8.8 MAINTENANCE EVERY 500 HOURS OF OPERATION".

4.8.4 MAINTENANCE EVERY 50 HOURS OF OPERATION

4.8.4.a CHECKING THE TIRE PRESSURE

WARNING

- Inflate the tires standing beside the outer belt.
- Do not exceed the pressures recommended in the "5.1.3 TECHNICAL CHARACTERISTICS".

This check is indispensable for the preservation, exploitation and duration of the tires.

The pressure must be as indicated in the specifications (see "5.1.3 TECHNICAL CHARACTERISTICS").

While checking the tire pressure, check also the conditions of the tread and sidewalls.

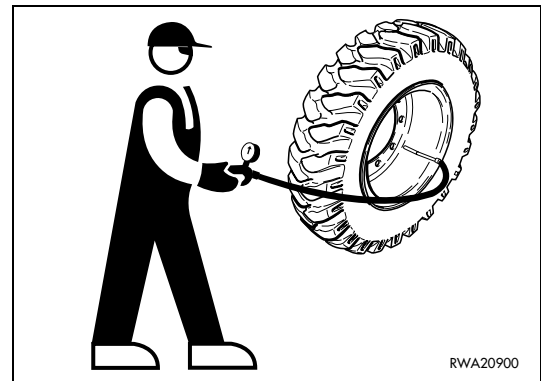

4.8.4.b CHECKING THE COOLANT LEVEL IN THE RADIATOR

WARNING

- Carry out this check with the machine parked on a level surface and the equipment resting on the ground.
- Do not remove the radiator cap when the fluid is hot, since it may be sprayed out violently and cause burns.
- Loosen the cap slowly in order to release the pressure before removing it.

The radiator cap can be reached after raising the engine hood (see "3.5.1 ENGINE HOOD").

Remove the cap (1) and make sure that the fluid level reaches the filling hole.

IMPORTANT

- If the fluid level in the radiator is low and the expansion tank is full of coolant, check the tightness of the radiator and make sure that there is no air leakage from the radiator-expansion tank coupling.

If this inconvenience occurs repeatedly, contact your Komatsu Distributor.

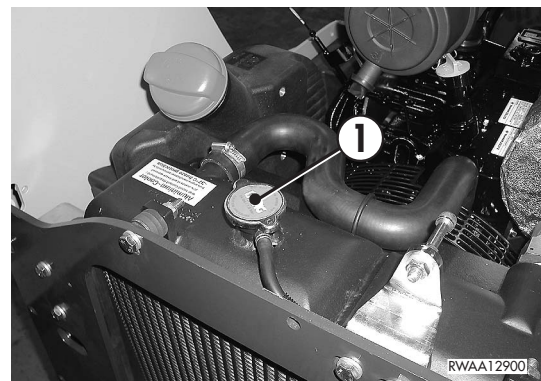

BLEEDING THE CIRCUIT

After filling the tank, turn the ignition key to position «I» and wait for approximately 15-20 seconds, in such a way as to bleed the fuel supply circuit.

IMPORTANT

- After bleeding the circuit, turn the ignition key to position «0» for a few seconds and wait at least 2 minutes before starting the engine.
- If the engine starts without problems and then stops or works irregularly, check if there is air in the circuit; if so, check the tightness of the fuel filter and of the fuel pump prefilter.
- After the fuel has run out, bleed the circuit by proceeding as described above and repeat the operation for at least 2-3 times.

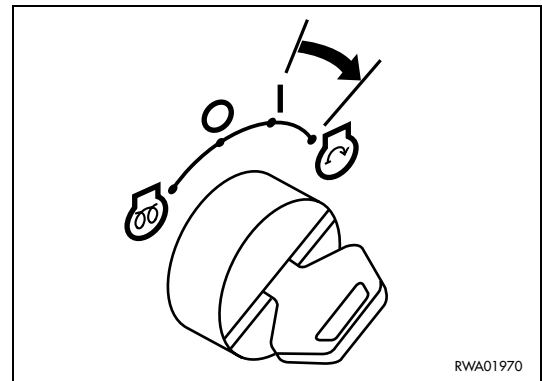
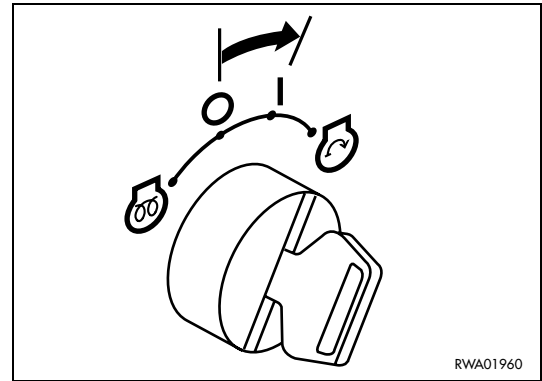

4.8.10.b CHANGING THE SUCTION FILTER

WARNING

- Lower the loader arm completely, rest the bucket on to the ground, stop the engine, eliminate the residual pressures that may be present in the equipment (by operating the controls more than once) and lock the safety bars (see "3.3.5 pos. 1 - SAFETY BARS").
- Before carrying out any maintenance operation, let the oil cool down until it reaches 40-45°C (104-113°F).
- Immediately clean any area dirty with oil.
- Oils, filters, coolants and batteries are considered special waste and must be collected and disposed of according to the anti-pollution regulations in force.

Stop the machine on a firm and level surface, lower the equipment to the ground, stop the engine and release the residual pressures from the equipment by operating the controls more than once.

Raise the engine hood (see "3.5.1 ENGINE HOOD") and open the rear panel (see "3.5.2 REAR PANEL").

The suction filter must be changed every two hydraulic oil changes.

- 1 - Slowly loosen the filling cap (1) in order to release the residual pressure from the tank and then remove it.

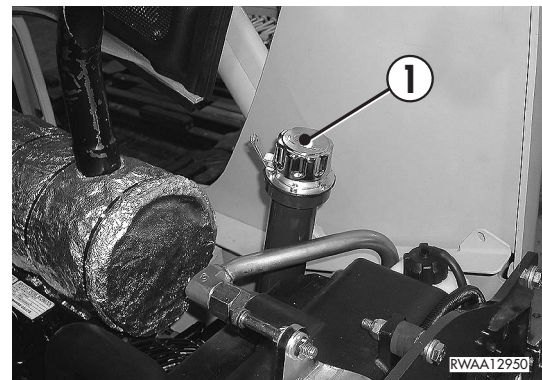
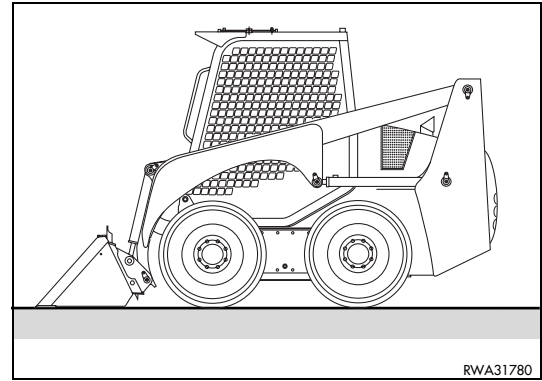

6.1 AUTHORIZED OPTIONAL EQUIPMENT

CAUTION

- **Komatsu machines can be supplied with optional equipment in addition to the standard equipment; if optional equipment is installed and used, carefully read the relevant operation manual and keep to the instructions given therein.**
 - **Use exclusively optional or special equipment recommended and approved by Komatsu and complying with the requisites indicated in the table (see "6.1.3 CHARACTERISTICS OF THE STANDARD MACHINE OPTIONAL EQUIPMENT").**
 - **Komatsu cannot be held liable for any damage, accident, reduction of the machine efficiency due to the application and use of unauthorized equipment.**
-

6.1.1 PRECAUTIONS REGARDING SAFETY

The installation of optional accessories or equipment other than those authorized by Komatsu shortens the life of the machine and may also cause problems concerning safety.

It is advisable to contact a Komatsu Dealer before installing any accessory not indicated in this operation and maintenance manual.

In case of failure to comply with this recommendation, Komatsu declines any responsibility for accidents or damage.

WARNING

- **When removing or installing any equipment, take the following precautions and be careful to the safety conditions.**
 - **Carry out installation and removal on a firm and flat surface.**
 - **When the operations are carried out by two or more operators, decide the communication signals in advance and respect them during the operations.**
 - **Use a crane to handle objects weighing more than 25 kg (55 lb).**
 - **Always support any heavy part before removing it. When heavy parts are lifted, be always careful to the position of the center of gravity of the object being handled.**
 - **It is very dangerous to carry out any operation with a suspended load; therefore, always position the load on a support and make sure that it is in a safe position.**
 - **When installing or removing any equipment, make sure that it is stable and cannot fall down.**
 - **Never stand under loads being lifted by a crane.**
Take care to choose a safe position, where you do not run any risk in case the load should fall down.
 - **Cranes must be operated by specialized personnel. Do not allow non-specialized personnel to use cranes.**
 - **For further details regarding installation and removal operations, contact your Komatsu Dealer.**
-

6.1.2 PRECAUTIONS REGARDING THE INSTALLATION OF EQUIPMENT

WARNING

- **The use of lengthened work equipment reduces the stability of the machine.**
If it is necessary to go up or down a slope, be particularly careful, since the machine may lose its balance and overturn.
 - **When installing work equipment with dimensions exceeding those of the standard equipment, be careful to the space necessary for the movements of the equipment and of the machine.**
-

6.4.1.1 TRAVEL AND STEERING CONTROL LEVERS

⚠ WARNING

- Before carrying out any maneuver with this levers, the operator must be seated in the work position with fastened seat belt and the safety bars in the unlocked (horizontal) position; before every maneuver the operator must take all the precautions indicated in "6.4.2 HOW TO MOVE THE MACHINE (HAND & FOOT CONTROL SYSTEM)".
- Before moving, make sure that the safety bars are in the horizontal (unlocked) position and the parking brake is disengaged.
- When traveling on roads, always lock the equipment control (see "3.3.5 pos. 8 - EQUIPMENT CONTROL LOCKING LEVER (IF INSTALLED)").
- When traveling on roads, always make sure that all safety devices have been engaged.
- Before leaving the work position, lower the equipment to the ground and lock the safety bars (vertical position), then stop the engine.
- Non-compliance with these rules may lead to serious accidents.

The travel control levers (1) and (2) are positioned on the Operator's left and right side, respectively, and they control the forward and reverse travel of the machine according to the movements shown in the diagram.

IMPORTANT

- To move the machine forward or in reverse, shift the levers (1) and (2) at the same time and in the same direction.
- For further details on the use of the levers, see pos. HOW TO MOVE THE MACHINE (HAND & FOOT CONTROL SYSTEM)"

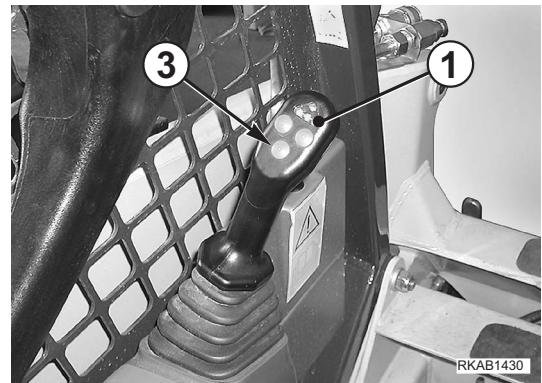

- N - Neutral
- A - Forward
- B - Reverse

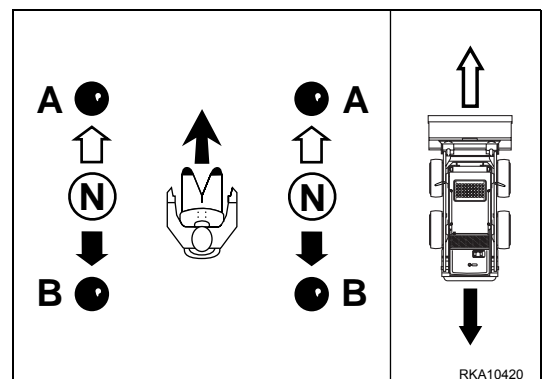

CLICK HERE TO **DOWNLOAD** THE COMPLETE MANUAL

- Thank you very much for reading the preview of the manual.
- You can download the complete manual from: www.heydownloads.com by clicking the link below



- Please note: If there is no response to CLICKING the link, please download this PDF first and then click on it.

CLICK HERE TO **DOWNLOAD** THE COMPLETE MANUAL