

Operation & Maintenance Manual

UENAM01652

PC700LC-11E0

HYDRAULIC EXCAVATOR

SERIAL NUMBER

PC700LC-11E0 - K75001 and up



WARNING

Unsafe use of this machine may cause serious injury or death. Operators and maintenance personnel must read this manual before operating or maintaining this machine. This manual should be kept inside the cab for reference and periodically reviewed by all personnel who will come into contact with the machine.

ORIGINAL INSTRUCTIONS

KOMATSU

CLICK HERE TO **DOWNLOAD** THE COMPLETE MANUAL

- Thank you very much for reading the preview of the manual.
- You can download the complete manual from: www.heydownloads.com by clicking the link below



- Please note: If there is no response to CLICKING the link, please download this PDF first and then click on it.

CLICK HERE TO **DOWNLOAD** THE COMPLETE MANUAL

VIBRATION LEVELS

When used for its intended purpose, levels of vibration for the earth-moving machine transmitted from the operator's seat are lower than or equal to the tested vibrations for the relative machinery class in compliance with ISO 7096.

For PC700LC-11 E0

The actual acceleration value for the hands and arms is less than or equal to 2.5 m/s^2 , the uncertainty for this value is 0.46 m/s^2 according to EN12096:1997.

The actual acceleration value for the body is less than or equal to 0.5 m/s^2 , the uncertainty for this value is 0.26 m/s^2 according to EN12096:1997.

These values were determined using a representative machine and measured during the typical operating condition indicated below according to the measurement procedures that are defined in the standards ISO 2631/1 and ISO 5349.

VIBRATION - OPERATING CONDITION

Excavating (Digging-loading-rotating-unloading-rotating)

GUIDE TO REDUCE VIBRATION LEVELS ON MACHINE

The following guides can help an operator of this machine to reduce the whole body vibration levels:

1. Use the correct equipment and attachments.
2. Maintain the machine according to this manual
 - Tension of crawler (for crawler machines)
 - Brake and steering systems
 - Controls, hydraulic system and linkages
3. Keep the terrain where the machine is working and travelling in good condition
 - Remove any large rocks or obstacles
 - Fill any ditches and holes
 - Site manager should provide machine operators with machine and schedule time to maintain terrain conditions
4. Use a seat that meets ISO 7096 and keep the seat maintained and adjusted
 - Adjust the seat and suspension for the weight and size of the operator
 - Wear seat belt
 - Inspect and maintain the seat suspension and adjustment mechanisms
5. Steer, brake, accelerate, and move the attachment levers and pedals slowly so that the machine moves smoothly
6. Adjust the machine speed and travel path to minimize the vibration level
 - When pushing with bucket or blade, avoid sudden loading; load gradually
 - Drive around obstacles and rough terrain conditions
 - Slow down when it is necessary to go over rough terrain
 - Make the curve radius of travelling path as large as possible
 - Travel at low speed when travelling around sharp curves
7. Minimize vibrations for long work cycle or long distance travelling
 - Reduce speed to prevent bounce
 - Transport machines long distances between worksites
8. The following guidelines can be effective to minimize risks of low back pain
 - Operate the machine only when you are in good health
 - Provide breaks to reduce long periods of sitting in the same posture

OPERATION	3-1
GENERAL VIEW	3-2
MACHINE EQUIPMENT NAME	3-2
CAB EQUIPMENT NAMES	3-4
CONTROLS AND GAUGES NAMES	3-5
EXPLANATION OF COMPONENTS	3-8
EXPLANATION OF MACHINE MONITOR EQUIPMENT	3-8
SWITCHES	3-89
CONTROL LEVERS AND PEDALS	3-97
OTHER EQUIPMENT	3-100
MACHINE OPERATIONS AND CONTROLS	3-138
CHECKS AND ADJUSTMENT BEFORE STARTING ENGINE	3-138
METHOD FOR STARTING ENGINE	3-168
METHOD FOR OPERATIONS AND CHECKS AFTER STARTING ENGINE	3-172
METHOD FOR STOPPING ENGINE	3-181
METHOD FOR STARTING MACHINE (TRAVEL FORWARD AND REVERSE) AND STOPPING MACHINE	3-184
METHOD FOR STEERING MACHINE	3-187
METHOD FOR SWINGING MACHINE	3-189
METHOD FOR OPERATING WORK EQUIPMENT	3-189
HANDLE WORKING MODE	3-191
PROHIBITED OPERATIONS	3-193
PRECAUTIONS FOR OPERATION	3-197
PRECAUTIONS FOR WORKING ON SLOPE	3-199
METHOD FOR ESCAPING FROM MUD	3-200
RECOMMENDED APPLICATIONS	3-201
EFFECTIVE USE OF HYDRAULIC EXCAVATOR	3-202
METHOD FOR REPLACING AND INVERTING BUCKET	3-203
METHOD FOR CHANGING BUCKET	3-203
METHOD FOR PARKING MACHINE	3-205
METHOD FOR CHECKING AFTER FINISHING WORK	3-206
LOCK	3-207
HANDLE AIR CONDITIONER	3-212
EXPLANATION OF AIR CONDITIONER EQUIPMENT	3-213
METHOD FOR OPERATING AIR CONDITIONER	3-217
HANDLING RADIO	3-226
EXPLANATION OF RADIO EQUIPMENT	3-226
METHOD FOR CONTROLLING RADIO	3-228
STOW ANTENNA	3-231
SPACE FOR RADIO CASSETTE	3-231
KomVision	3-232
PRECAUTIONS WHEN USING KomVision	3-232
MONITOR DISPLAY	3-232
TRANSPORTATION	3-234
PRECAUTIONS FOR TRANSPORTING MACHINE	3-234
SELECT TRANSPORTATION METHOD	3-234
METHOD FOR LIFTING MACHINE	3-234
PRECAUTIONS FOR LOADING MACHINE	3-235
MACHINE CONFIGURATION FOR TRANSPORTATION	3-236
SPREAD AND NARROW TRACK FRAME GAUGE	3-239
COLD WEATHER OPERATION	3-242
COLD WEATHER OPERATION INFORMATION	3-242
PRECAUTIONS AFTER DAILY WORK COMPLETION IN COLD WEATHER	3-243
AFTER COLD WEATHER SEASON	3-244
PRECAUTIONS FOR LONG-TERM STORAGE	3-245
PREPARATION FOR LONG-TERM STORAGE	3-245
MAINTENANCE DURING LONG-TERM STORAGE	3-245
STARTING MACHINE AFTER LONG-TERM STORAGE	3-245

(f) Caution when standing

Before standing up from the operator's seat or when adjusting the operator's seat, always lower the work equipment completely to the ground, set lock lever (1) securely to the LOCK position (L), then stop the engine.

If you accidentally touch the control levers (pedals) when they are not locked, there is a hazard that the machine may suddenly move and cause serious injury or property damage.

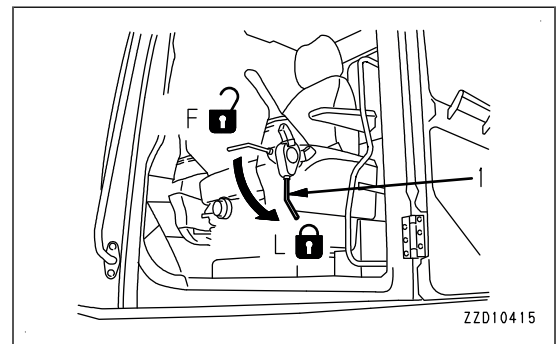
**(g) Warning - Prohibition of getting on the machine**

No passengers allowed to ride on the machine while it is moving.

**(h) Warning - Caution for falling object**

Do not operate where a danger of falling objects exists.

Consult your dealer for fitting of FOPS (FALLING OBJECT PROTECTIVE STRUCTURE) protection.



- Do not grip the control levers or lock lever when getting on or off the machine.
- Never climb on the engine hood or covers where there are no non-slip pads.
- Do not get on or off the machine with tools in your hand.
- Do not grab a foldable mirror as a handrail since it turns.

NO JUMPING ON OR OFF MACHINE

Getting on or off the moving machine can cause serious personal injury or death. Always observe the following.

- Never jump on or off the machine. Never get on or off a moving machine.
- If the machine starts to move when there is no operator on the machine, do not jump on to the machine and try to stop it.

LIFTING OF PERSONNEL PROHIBITED

Under no circumstances should this machine be used for the lifting of personnel.

NO PEOPLE ON ATTACHMENTS

Never let anyone ride on the work equipment or other attachments. There is a hazard of falling and suffering serious personal injury or death.

PRECAUTIONS WHEN STANDING UP FROM OPERATOR'S SEAT

Be sure to lower the work equipment completely to the ground before standing up from the operator's seat, such as when opening or closing the front window or ceiling window, when removing or installing the bottom window, or adjusting the position of the seat. Operate the operating portion (g) of the lock lever (1) to set it to LOCK position (L) and stop the engine.

If the control levers are touched by mistake, there is danger that the machine may suddenly move and cause serious personal injury or death.

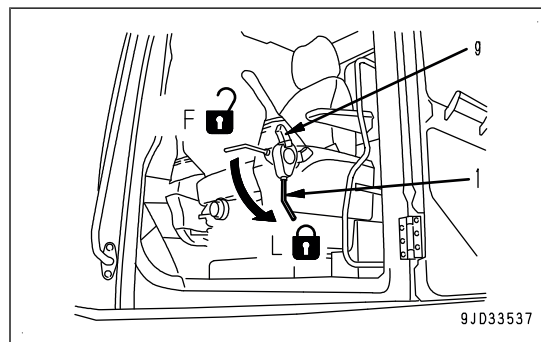

PRECAUTIONS WHEN LEAVING MACHINE

If the proper procedures are not taken when parking the machine, the machine may suddenly move off by itself, and this may lead to serious personal injury or death. Always observe the following.

- When passing over bridges or structures, check first that the structure is strong enough to support the weight of the machine. When passing on a public road, check with authorities concerned and observe their instruction.
- When operating in tunnels, under bridges, under electric wires, or other places where the height is limited, operate slowly and be extremely careful not to let the machine body or work equipment hit anything.

PRECAUTIONS WHEN TRAVELING ON SLOPES

To prevent the machine from tipping over or slipping to the side, always observe the following.

- Keep the work equipment at height (a) of approximately 20 to 30 cm above the ground. In case of emergency, lower the work equipment to the ground immediately to help stopping the machine.
- When driving the machine up slopes, set the operator's cab facing uphill, when driving downhill, set the operator's cab facing downhill. Always be sure of the safety of the ground under the front of the machine when driving.

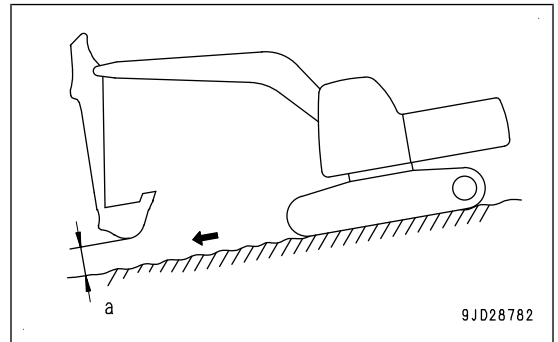
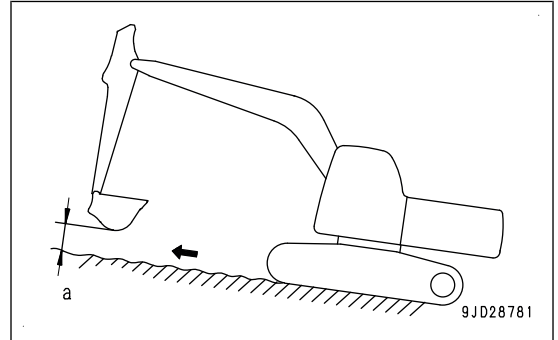

- When driving the machine up a steep slope, extend the work equipment to the front to improve the balance, keep the work equipment at height (a) of approximately 20 to 30 cm above the ground, and drive it at low speed.

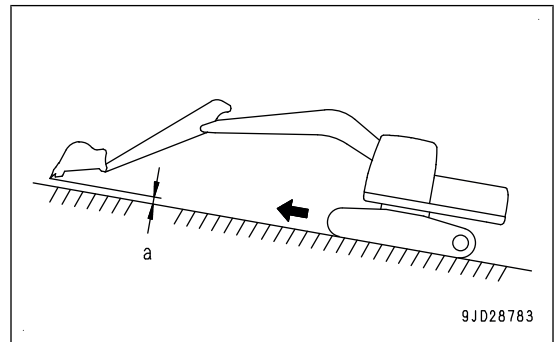

- When driving the machine downhill, lower the engine speed, keep the travel lever close to NEUTRAL position, and drive it at low speed.
- Always drive the machine straight up or down a slope. Driving the machine at an angle or across the slope is extremely dangerous.
- Do not turn on slopes or drive across slopes. Always go down to a flat place to change the position of the machine, then drive it on to the slope again.

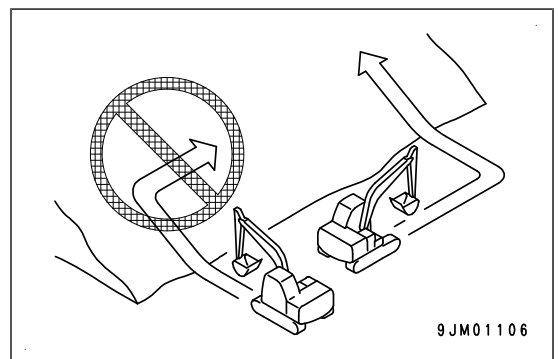

PRECAUTIONS WHEN WORKING UNDER MACHINE OR WORK EQUIPMENT

Machine or work equipment may fall, and it is dangerous that serious personal injury or death may occur. Always observe the following.

- Make sure the hoists or hydraulic jacks you use are in good condition and strong enough to handle the weight of the component. Never use hydraulic jacks at places where the machine is damaged, bent, or twisted. Never use if the element wire of wire rope is frayed, twisted or pinched. Never use bent or distorted hooks.
- It is extremely dangerous to work under the machine if the track shoes are lifted off the ground and the machine is supported only with the work equipment. If any of the control levers is touched by accident, or there is damage occurring to the hydraulic piping, the work equipment or the machine will suddenly fall. Never work under the work equipment or the machine.
- If it is necessary to raise the work equipment or the machine and then go under it to perform inspection or maintenance, support the work equipment and machine securely with blocks and stands strong enough to support the weight of the work equipment and machine.
If the work equipment and machine are not supported, they may come down and it may cause serious personal injury or death.
- Never use concrete blocks for supports. Concrete blocks may break under even light loads.



USE PROPER TOOLS

Use the tools suited to the task and use them correctly. Using damaged, deformed, or low quality tools, or making improper use of the tools may cause serious personal injury or death.

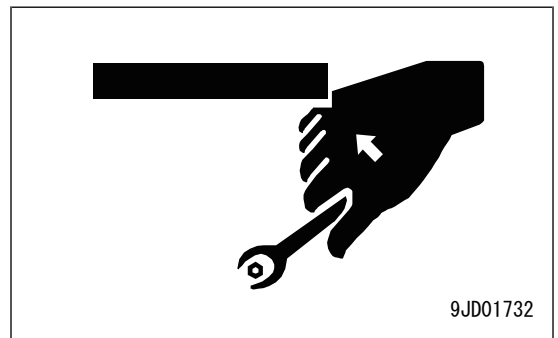

PRECAUTIONS FOR CHECK AND MAINTENANCE

TURN BATTERY DISCONNECT SWITCH TO OFF POSITION

In the following cases, turn the starting switch to OFF position and check that the system operating lamp is off. Then set the battery disconnect switch to OFF position and remove the switch key.

If you check and handle battery without turning battery disconnect switch to OFF position, serious personal injury or death by such as an electric shock may occur.

- When storing the machine for a long time (more than 1 month)
- When repairing the electrical system
- When performing electric welding
- When handling the battery
- When replacing the fuse, etc.

PRECAUTIONS FOR WELDING

Welding operations must always be performed by a qualified welder and in a place equipped with proper equipment. There is a hazard of gas, fire, or electric shock when performing welding, so never allow any unqualified person to perform welding.

Details of parts A and B

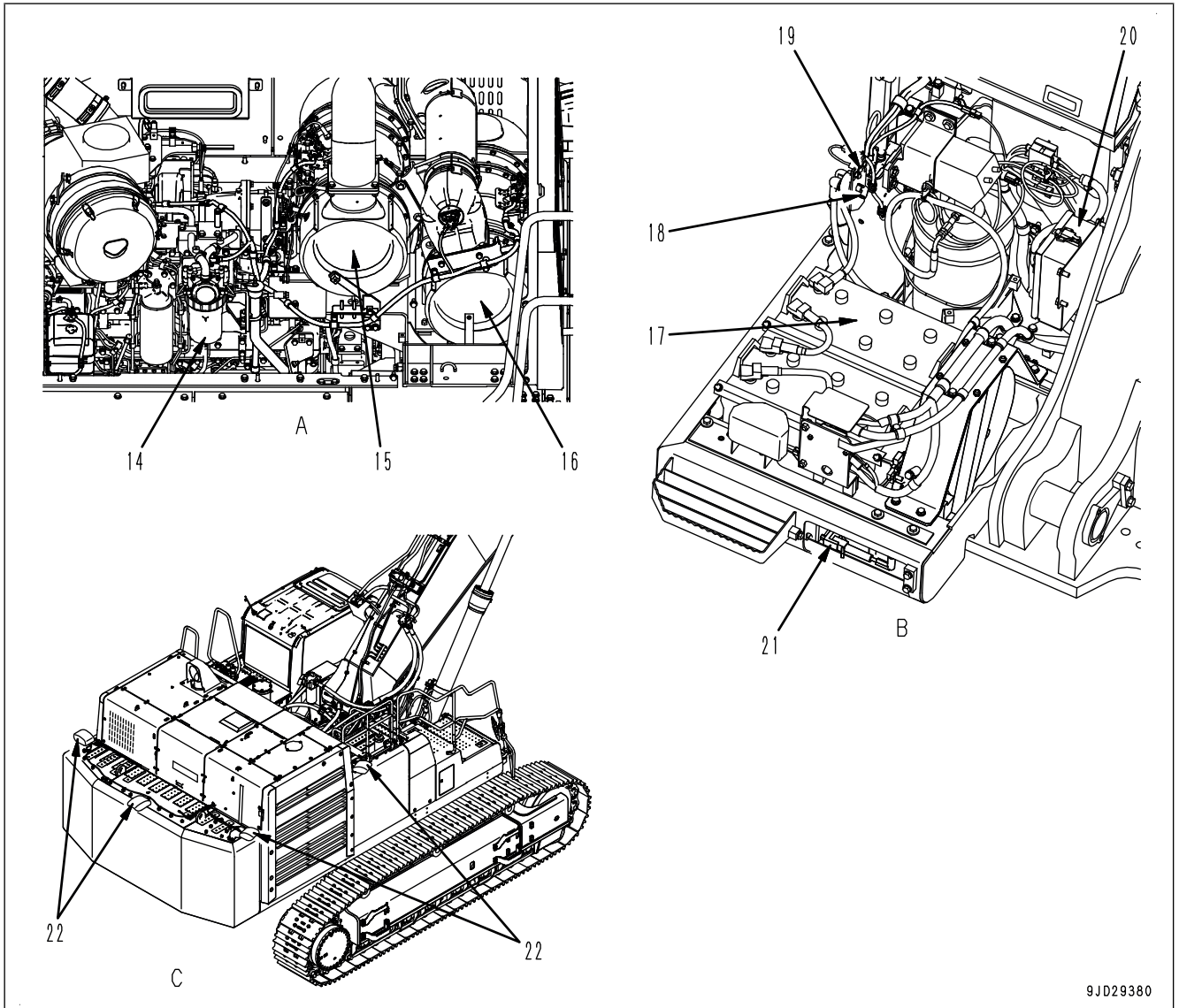

9JD29380

(14) Komatsu Closed Crankcase Ventilation (hereafter KCCV) ventilator

(15) SCR

(16) KDPF

(17) Battery

(18) Battery disconnect switch

(19) System operating lamp

(20) Circuit breaker

(21) Grease gun holder

(22) KomVision

BASIC OPERATION OF MACHINE MONITOR WHEN STARTING ENGINE IN ABNORMAL SITUATION

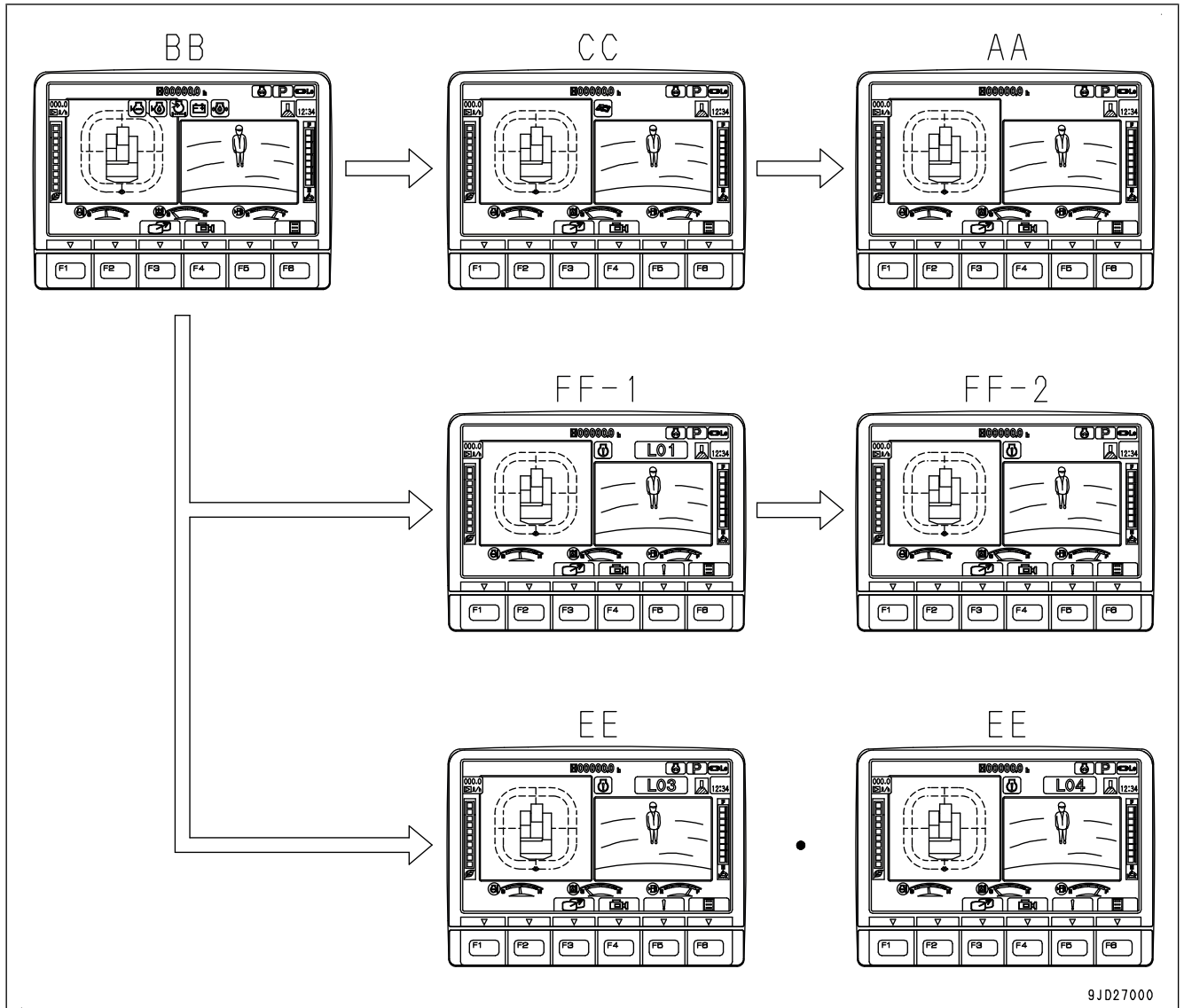

9JD27000

- If there is any abnormality when starting the engine, the check before starting screen BB changes to the maintenance time warning screen CC, warning screen FF, or error screen EE.
- After displaying the checks before starting screen BB for 2 seconds, the screen changes to the maintenance time warning screen CC.
- After displaying the maintenance time warning screen CC for 30 seconds, the screen returns to the standard screen AA.
- After displaying the check before starting screen BB for 2 seconds, the screen changes to the warning screen FF-(1) or error screen EE.
- After displaying warning screen FF-(1) for 2 seconds, the screen automatically changes to warning screen FF-(2).

Ask your Komatsu distributor for inspection and maintenance as needed.

KDPF SYSTEM CAUTION LAMP

The KDPF system caution lamp warns about abnormality in the KDPF system.

When action level “L04” is displayed

The caution lamp lights up in red and the alarm buzzer sounds continuously.

Stop the machine immediately and ask your Komatsu distributor for inspection and maintenance.

When action level “L03” is displayed

The caution lamp lights up in red and the alarm buzzer sounds intermittently.

Stop the operation and move the machine to a safe place, then ask your Komatsu distributor for inspection and maintenance.

When action level “L01” is displayed

The caution lamp lights up in yellow.

Some functions may be restricted for use, but the machine can operate.

When you finish the operation, always perform the inspection and maintenance.

Ask your Komatsu distributor for the inspection and maintenance as needed.

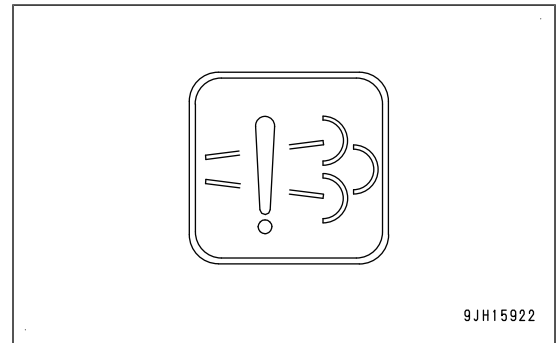

KDPF SOOT ACCUMULATION CAUTION LAMP

The KDPF soot accumulation caution lamp warns that soot is accumulated in KDPF or the filtering function of KDPF has lowered abnormally.

To cancel the alarm, perform the manual stationary regeneration of KDPF.

When abnormal

The caution lamp lights up in red and indicates action level “L03”.

The alarm buzzer sounds intermittently.

Large accumulation of soot in KDPF or a system failure such as lowering of the filtering function of KDPF occurs.

Urgent remedy is required.

Move the machine to a safe place immediately and perform the manual stationary regeneration.

The manual stationary regeneration may start automatically to protect KDPF system.

When soot is accumulated

The caution lamp lights up in yellow and indicates action level “L01”.

Much soot is accumulated in KDPF, however, the operation can be performed.

After the operation is finished, move the machine to a safe place and perform manual stationary regeneration.

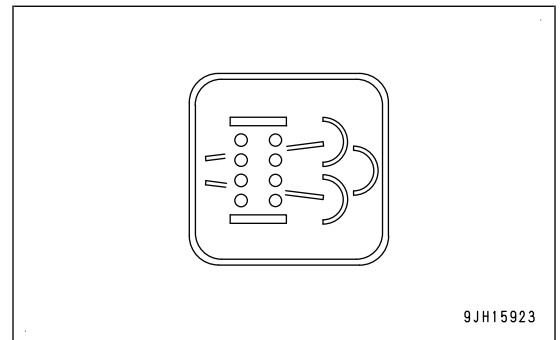

ONE-TOUCH POWER MAXIMIZING PILOT LAMP

One-touch power maximizing pilot lamp shows if the one-touch power maximizing function is being actuated.

The following pilot lamp is displayed when the knob switch on the L.H. control lever is operated. (The actual pilot lamp display is shown at the position of preheating pilot lamp.)

Pilot lamp lights up: Digging power increases while the knob switch is kept pressed (for a maximum of 8.5 seconds).

Pilot lamp goes out: Power maximizing function is stopped

REMARK

Only when the working mode is P and E mode, the power is increased while the knob switch is being pressed. Even if the knob switch continues to be pressed, the power maximizing operation ends in 8.5 seconds.

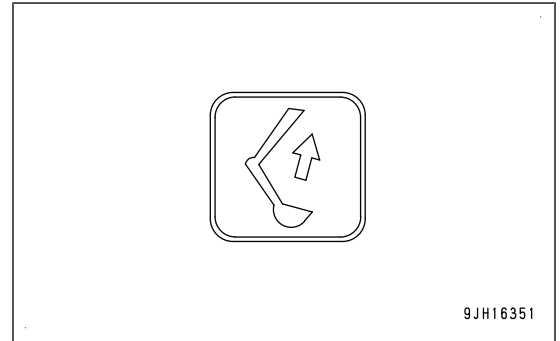

AIR CONDITIONER PILOT LAMP

The air conditioner pilot lamp shows the operating state of the air conditioner.

Pilot lamp lights up: Air conditioner ON

Pilot lamp goes out: Air conditioner OFF

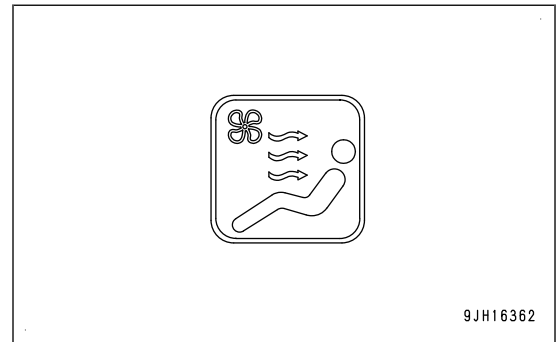

MESSAGE DISPLAY

The message display lights up when there is a message from Komatsu.

To read the message, see "MESSAGE DISPLAY".

Lights up in green (A): There is unread message.

Lights up in blue (B): There is any read message to which no reply is made.

OFF: No messages

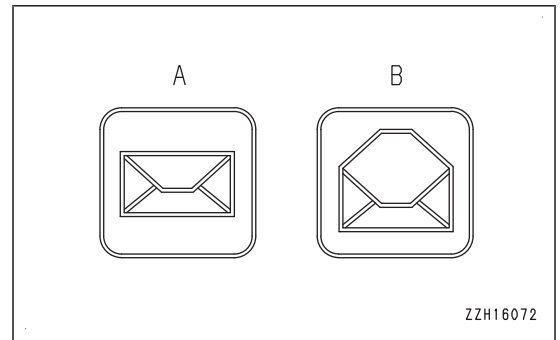

ENGINE STOP PILOT LAMP

The engine stop pilot lamp is displayed while the engine is stopped. It goes out when the engine is started.

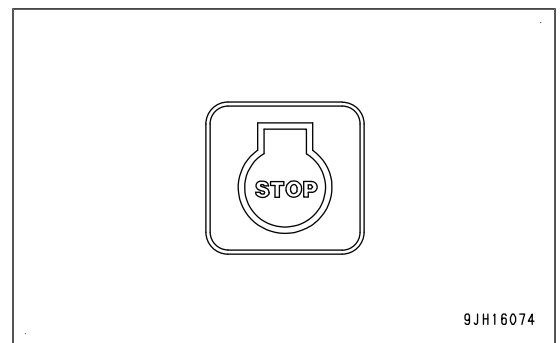

WORKING MODE SELECTOR SWITCH

Use the working mode selector switch (1) to set the movement or power of the work equipment.

The operation becomes easier by selecting the mode to match the content of the operation.

P mode: For heavy-duty operations

E mode: For operations with emphasis on fuel consumption

L mode: For fine control operations

- When the monitor is turned on, it is automatically set to the mode used when the starting switch was turned to OFF position last.
- Press the switch to display the working mode selection screen. For each set mode, P, E, and L are displayed on the working mode display (2) at the top right of the machine monitor display.

Ask your Komatsu distributor to change the setting if you want to have an automatic setting of P, E, and L mode (optional default setting) when starting the engine.

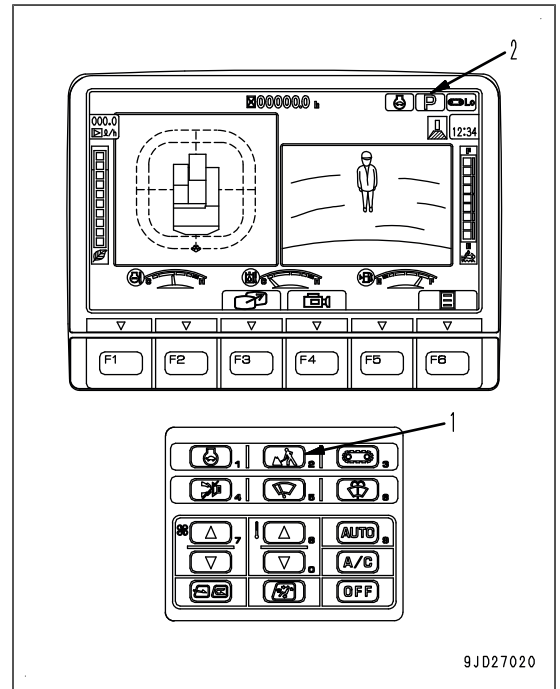

9JD27020

How to use the working mode selector switch

1. When working mode selector switch (1) is pressed, the working mode selector screen is displayed on the monitor.

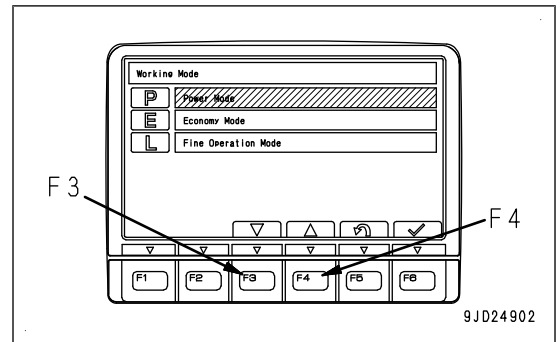

9JD24902

2. Press the switches F3 or F4 at the bottom of the screen or working mode selector switch (1) to change the mode selection one at a time.

If no switch is touched for more than 5 seconds, the selected working mode is automatically set as the working mode. The screen changes to the one for the steps 3 and 4.

REMARK

To return to the standard screen without changing the working mode, press switch F5.

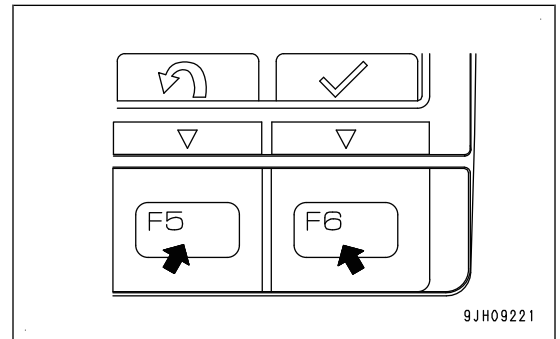

9JH09221

- Press the auto-deceleration switch to turn on or off the auto-deceleration function.

Even if the auto-deceleration switch is pressed, the camera image display screen neither switches to another screen nor returns to the standard screen display.

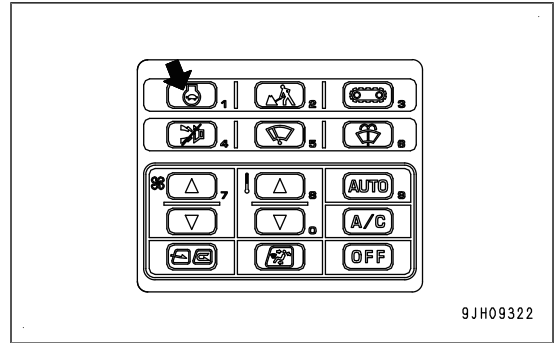

- Press the buzzer cancel switch to stop the alarm buzzer for the warning item where there is an abnormality.

Even if the buzzer cancel switch is pressed, the camera image display screen neither switches to another screen nor returns to the standard screen. Depending on the warning, alarm buzzer does not stop sounding by pressing the buzzer cancel switch.

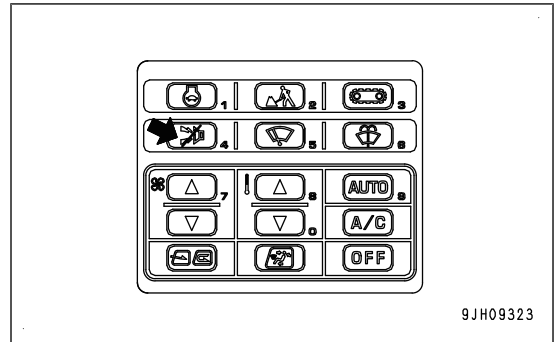

- Press the wiper switch and washer switch to operate the wipers and washer.

Even if the wiper switch or washer switch is pressed, the camera image display screen neither switches to another screen nor returns to the standard screen.

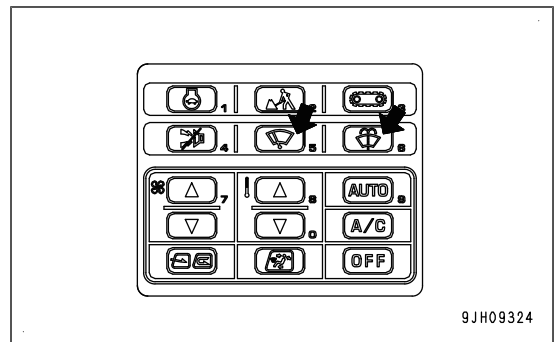

ACTIONS AGAINST WARNING DURING CAMERA IMAGE DISPLAY

- If any abnormality is generated on the machine while the camera image is displayed, the caution lamp flashes at the top left of the screen.

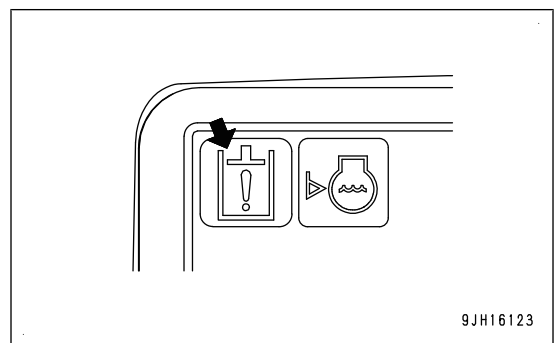
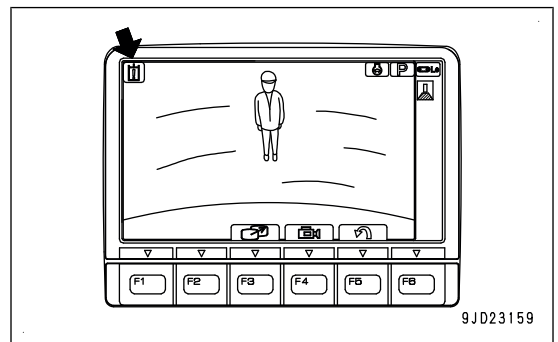

REMARK

When you select the split measurement, the measurement stop switch (STOP) is displayed on the Operation Records screen and the ECO Guidance Records screen.

When you stop the measurement, move from Energy Saving Guidance menu (a) screen to the Operation Records (1) screen or ECO Guidance Records (2) screen, then press the measurement stop switch F1 (STOP).

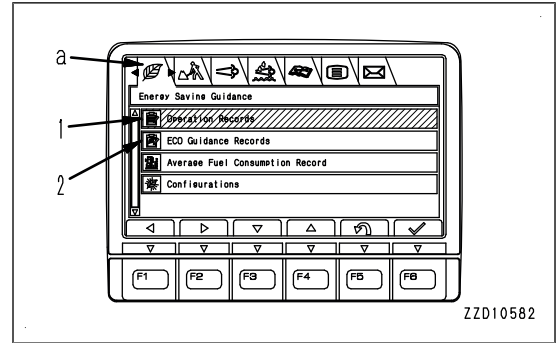

ZZD10582

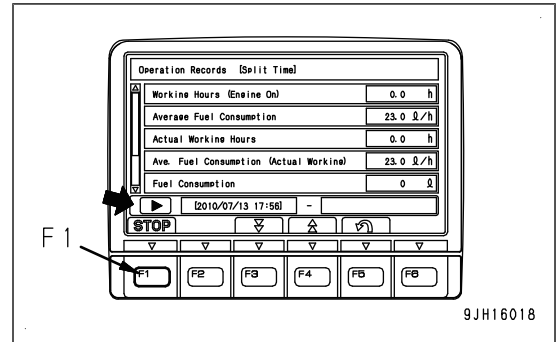

9JH16018

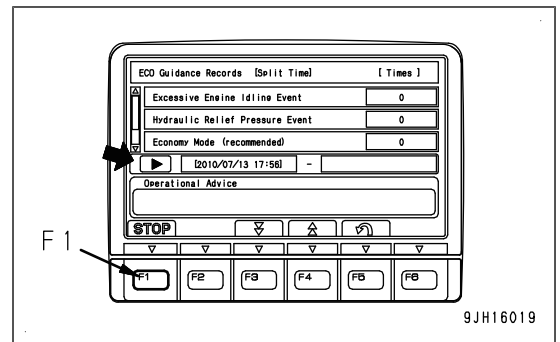

9JH16019

SWITCH DISPLAY/NON-DISPLAY OF ECO GAUGE

It is possible to change the setting of Display/Non-display of ECO gauge (7).

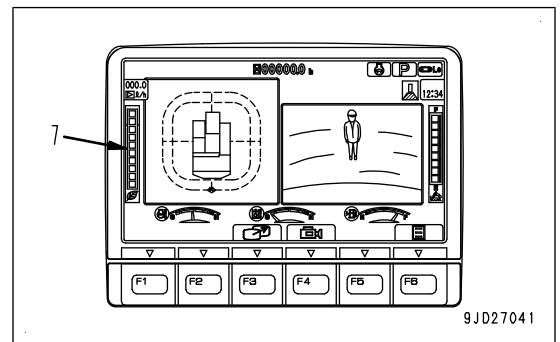

9JD27041

1. Select the ECO Gauge display (8) from the Configurations screen, then press switch F6.
2. ECO Gauge Display setting screen appears.
 ON: Displays the ECO gauge (7) on the standard screen.
 OFF: Does not display ECO gauge (7) on the standard screen.

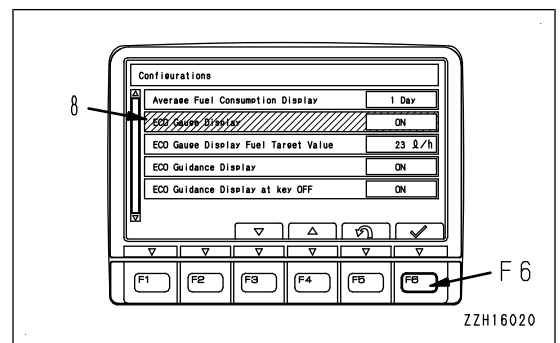

ZZH16020

7. To return the fan rotation direction from reverse to normal, press the switch F5 on the screen shown in the figure.

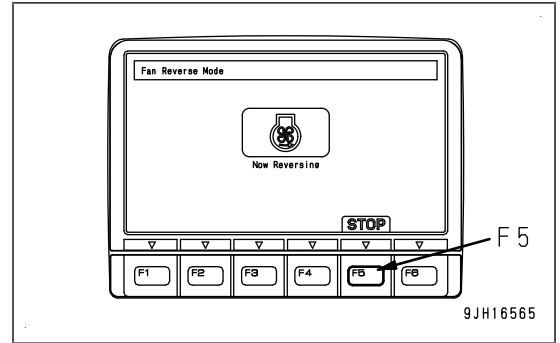

8. Press the switch F6 when the confirmation screen shown in the figure is displayed.
(If switch F5 is pressed, the screen returns to the previous screen.)

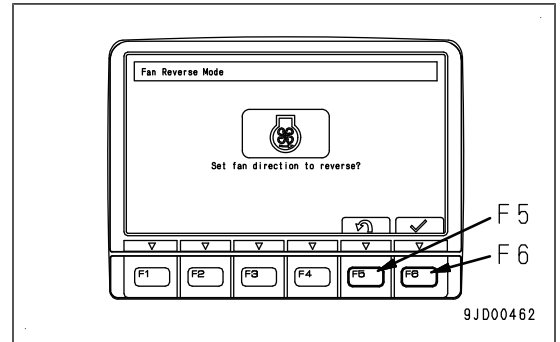

9. If the screen shown in the figure is displayed, the engine speed is set to low idle automatically and the fan rotation direction is returned to normal in approximately 15 seconds. Approximately 4 seconds after, the engine speed returns to the original level.

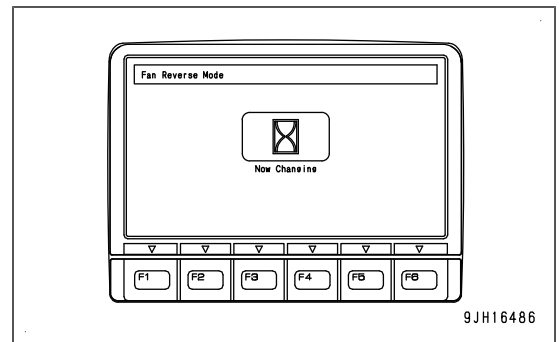

10. When the fan rotation direction returns to normal, the standard screen is displayed automatically.

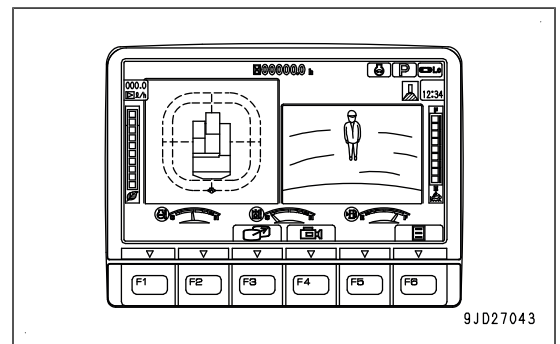

2. "12h/24h Mode" screen appears.
 - F3: Moves to the next item (1 line below). Moves to the top line when it is on the bottom line.
 - F4: Moves to the previous item (1 line above). Moves to the bottom line when it is on the top line.
 - F5: Cancels the change and returns the screen to "Clock Adjustment" screen.
 - F6: Accepts change and returns to "Clock Adjustment" screen.

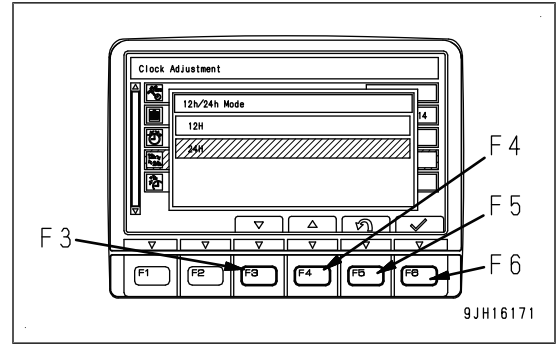

DAYLIGHT SAVING TIME (SUMMER TIME) SETTING

If "Daylight Saving Time" is turned on, the clock display becomes 1 hour forward. If "Daylight Saving Time" is turned off, the clock display returns to the set time.

1. Select "Daylight Saving Time" (e) on "Clock Adjustment" screen, then press switch F6.

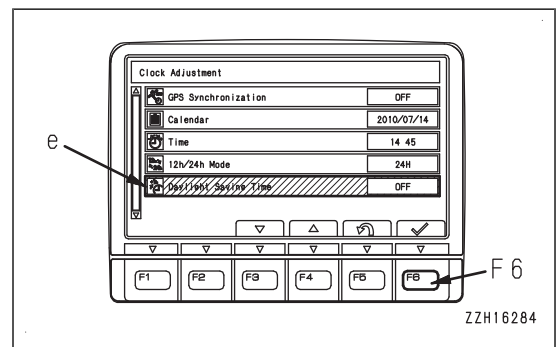

2. The "Daylight Saving Time" screen is displayed.
 - F3: Moves to the next item (1 line below). Moves to the top line when on the bottom line.
 - F4: Moves to the previous item (1 line above). Moves to the bottom line when on the top line.
 - F5: Cancels change and returns to "Clock Adjustment" screen.
 - F6: Accepts change and returns the screen to "Clock Adjustment" screen.

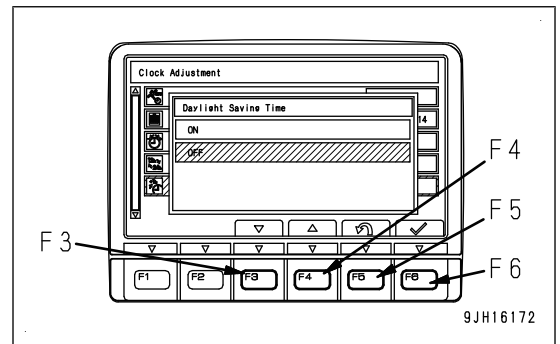

REMARK

Daylight saving time or summer time means moving the clock forward an hour to take advantage of the fact that the sun rises early in summer in our daily life.

LANGUAGE SETTINGS

On "Language Setting" menu, it is possible to select the language used on the monitor display.

The languages that can be selected are as follows.

Japanese, English, German, French, Spanish, Portuguese, Italian, Swedish, Dutch, Danish, Norwegian, Finnish, Icelandic, Czech, Hungarian, Polish, Slovak, Slovene, Estonian, Latvian, Lithuanian, Bulgarian, Greek, Romanian, Croatian and Serbian

If the Current Abnormality list includes any of the hydraulic system errors “DXA3KB”, “DXA2KB”, “DXA3KA” or “DXA2KA”, you can perform operation temporarily by setting this switch to “Emergency” position (a).

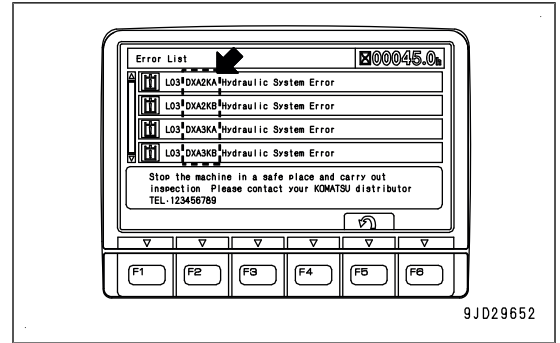

SWING PARKING BRAKE CANCEL SWITCH

NOTICE

Swing operations can be performed temporarily with swing parking brake cancel switch when there is a problem in the swing parking brake system. Do not use it except for emergency. Repair the problem as soon as possible.

Swing operations can be performed temporarily with swing parking brake cancel switch when there is a problem in the swing parking brake system (when the upper structure does not swing but the display does not show “L03”).

(a) Cancel

When abnormal (switch is set up)

(b) Normal

When normal (switch is pushed down)

- When the upper structure does not swing but the display does not show “L03”, move this switch to Cancel position (a), and operation can be performed.
- When the switch is moved to Cancel position (a), the swing lock pilot lamp flashes.

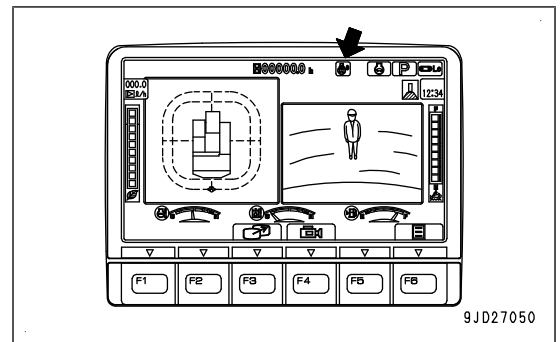
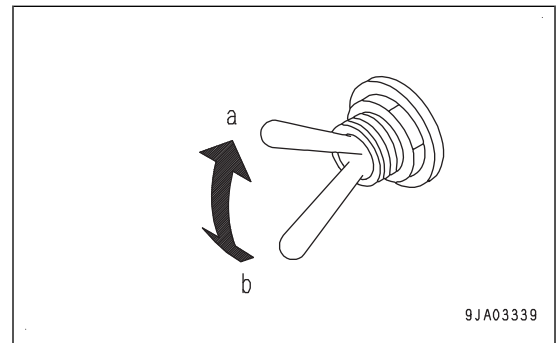

LOCK LEVER AUTOMATIC LOCK CANCEL SWITCH

NOTICE

The lock lever automatic lock cancel switch is used to disable the lock lever automatic lock function and enable the operations of the work equipment and machine temporarily, when the lock lever automatic lock function is abnormal. Use this switch only when the machine or working machine needs to be moved temporarily in an abnormal and emergency condition. Repair the problem as soon as possible.

NOTICE

While removing the ashtray, if it is stuck in the console cover and hard to be removed, open lid (A) of ashtray, then hold the ashtray body (B) and twist it to remove. If you hold lid (A) of ashtray and twist it, the ashtray may break.

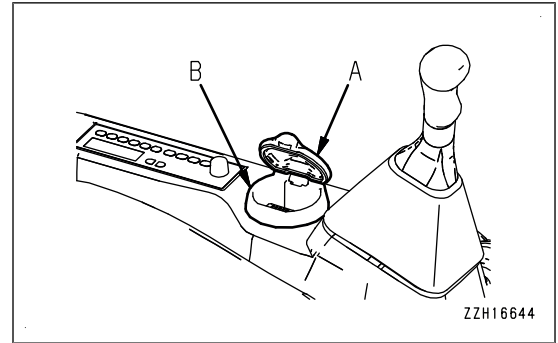
**POWER SUPPLY OUTLET****24 V power source****NOTICE**

Do not use it as a power supply for 12 V equipment. This will cause failure of the equipment.

When cigarette lighter is removed, the lighter socket can be used as a power source.

The capacity of the cigarette lighter is 85 W (24 V x 3.5 A).

REMARK

Use 24 V power source while engine is running.

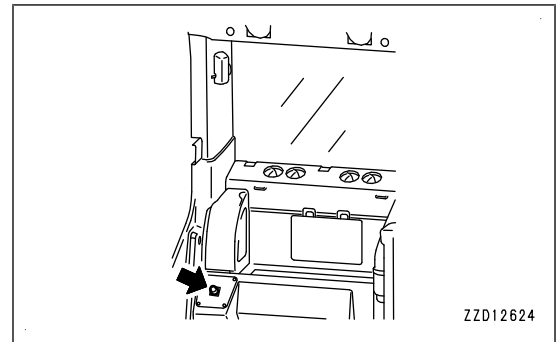
**12 V power source**

This power source can be used up to a capacity of 144 W (12 V x 12 A).

When it is used at 1 place: 144 W (12 V x 12 A)

When it is used at 2 places: 144 W in total

REMARK

Use 12 V power source while engine is running.

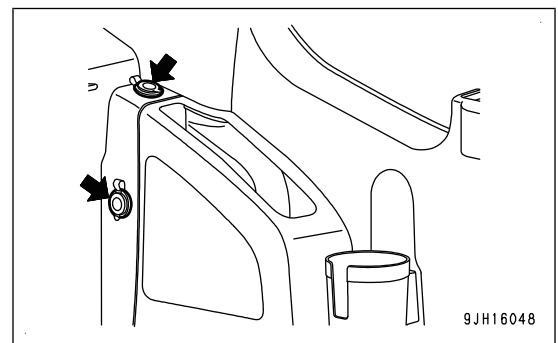
**FUSE****NOTICE**

Before replacing a fuse, be sure to turn the starting switch to OFF position, then turn the battery disconnect switch to OFF position.

- The fuse holder is at the rear of the operator's seat.
- The fuses protect the electrical component and wiring from burning out.
- If the fuse becomes corroded, or white powder can be seen, or the fuse is loose in the fuse holder, replace the fuse.
- Replace the fuse with the one of the same capacity.

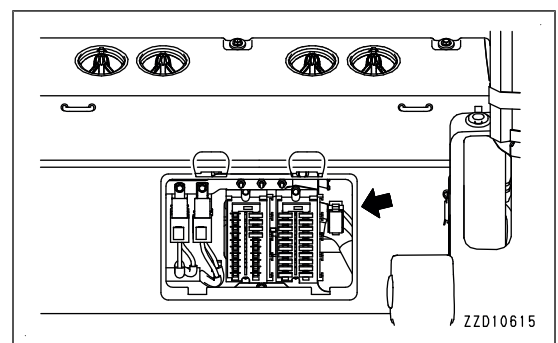

REMARK

- Soot accumulation level (4) can be checked with the “Aftertreatment Devices Regeneration” screen. Press function switch F6 on the standard screen to display the “Aftertreatment Devices Regeneration” screen of the user menu.
- Since the soot in the filter of KDPF can be burnt by the high-performance catalyst and high-temperature exhaust heat, the soot accumulation quantity may decrease even if the regeneration is not performed, depending on the operating condition.
- Even when the soot accumulation level is low, the automatic regeneration may be performed and the manual stationary regeneration may be requested to protect the system. In particular, if engine is kept running with no load, the regeneration frequency may increase, but this is not a failure.
- Even just after the regeneration is completed, the soot accumulation level may not be “0”. This is caused by the accumulated noncombustible material in the exhaust gas and is not a failure.
- Since noncombustible matter which cannot be burnt by the regeneration is accumulated in the filter of KDPF, the filter needs to be cleaned or replaced at regular intervals.
- The engine speed or engine sound may change during or after the regeneration. This is caused by the control for better regeneration and this is not a failure.
- The smell of the exhaust gas is different from that of the conventional diesel engine because of the exhaust gas filtering function.
- White smoke may be discharged for a short time just after the engine is started or during the regeneration in the cold season, but this is not a failure.
- Komatsu recommends using Komatsu genuine engine oil for KDPF. If engine oil other than Komatsu genuine oil for KDPF is used, it may shorten cleaning interval of KDPF filters, adversely affect the engine such as deteriorated oil may reduce lubricating function, and it may cause failure. In addition, the regeneration interval may be shortened and the fuel consumption may increase.
- Ash is easy to be accumulated in KDPF when the biofuel is used. Thus, the regeneration of KDPF can possibly become more frequent if the mixing ratio of the biofuel is high.

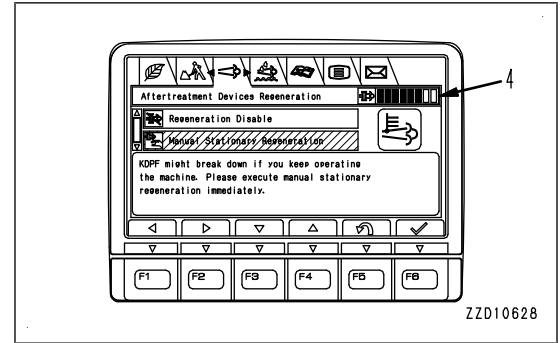

DEF is supplied from DEF system into the exhaust system. DEF system consist of DEF tank (1), DEF hose (2), DEF pump (3), and DEF injector (4). SCR Ass'y is indicated by (5).

In the event that indications of potential degradation of nitrogen oxides conversion efficiency are detected, the active regeneration is triggered to rejuvenate Urea SCR system even if the amount of soot accumulated in the KDPF has not reached to the regeneration thresholds.

⚠ WARNING

Fill ONLY DEF into DEF tank. Foreign material in the DEF system or urea deposits caused by evaporation may hinder operation of the devices.

NOTICE

- Do not disassemble any devices of the DEF system other than the filter for change. Do not modify any devices of the DEF system.
- Paint may cause deterioration of the devices. When painting the surrounding areas, take care not to get any paint on the injector and the supply pump.
- Always use DEF that conforms to the quality standard. If any additional additive agents or water is mixed in DEF and that mixture is used, the devices will not function properly, and conformance to the exhaust gas regulations will be lost. In addition, it may cause failures in the engine system. If DEF out of the standard is filled or used by mistake, contact your Komatsu distributor.

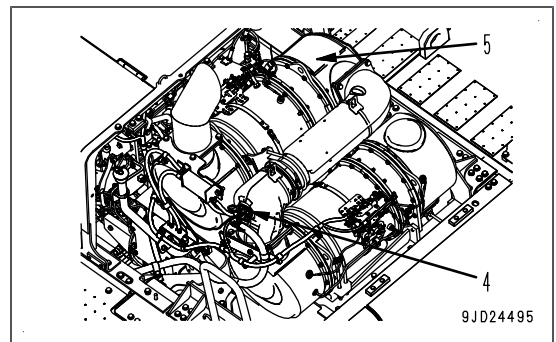
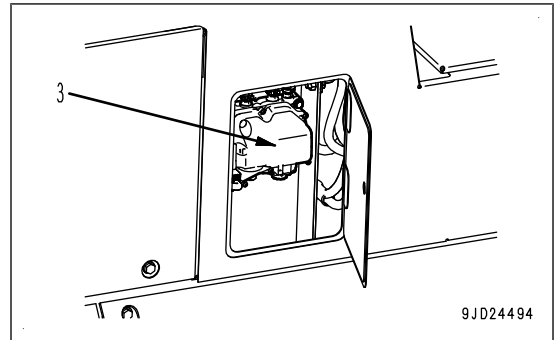
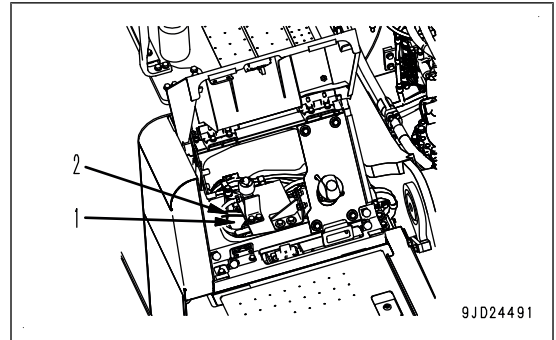

About the operation of Urea SCR system

The Urea SCR system automatically starts operating as soon as the engine is started.

Even after the engine starting switch is turned to the OFF position, the devices will still be in operation for several minutes to purge any DEF in the lines, the injector and the supply pump back to the DEF tank. It does not indicate any abnormality. When DEF has been returned to the tank, the devices stop.

Do not turn OFF the battery disconnect switch while the devices are still in operation. When the devices complete their shutdown process, the system operating lamp will go out, and the battery disconnect switch may be disconnected.

About the operation in cold weather

DEF freezes at -11°C .

Urea SCR system is equipped with a heating system to thaw frozen DEF once it is frozen, for example, during parking and to prevent DEF from freezing during operation.

In case DEF freezes during parking, once the engine starts running the heating system automatically starts providing heat to thaw frozen DEF. The pump and the injector start working only after a proper amount of DEF is thawed. This may be noticed as a delay in the start of functioning of the pump and the injector.

The heating system is also activated automatically during operation to prevent DEF from freezing whenever the ambient temperature drops below a certain threshold where DEF in the system may freeze. In the event that the ambient temperature drops further than a temperature where the heating system is capable of maintaining fluidity of DEF, the DEF system automatically starts purging the remaining DEF back to the tank and stops pumping and injection while heating continues. Once the ambient temperature rises above a temperature where DEF system becomes functional, it resumes operation automatically.

“SCR Information” screen message (5): 5 “Engine is running at low idle.”

Engine speed is fixed at low idle to disable practical machine operation.
Move the machine to a safe place and contact your Komatsu Distributor.

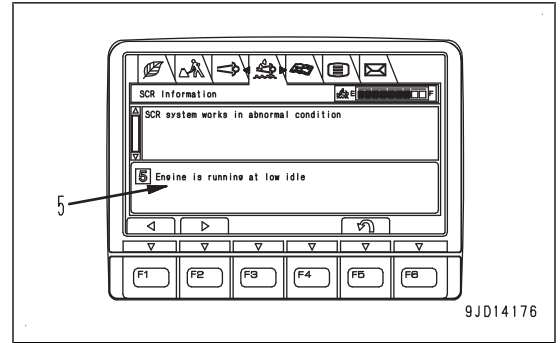

Temporary Restoration from Inducement

Temporary Restoration from Inducement is one of the Inducement strategies allowed to be included in Urea SCR systems.

In case the Urea SCR system advances to “Severe Inducement”, engine power is derated heavily. This may cause difficulties of moving the machine to a safe place for adding DEF or troubleshooting and correcting abnormalities of the Urea SCR system. For temporary remedies from these difficulties the operator can restore engine power for a short time to the deration of “Mild Inducement” through the machine monitor. Note that “Temporary Restoration from Inducement” does not regain full engine power.

“Temporary Restoration from Inducement” can be activated only when the Urea SCR system is in “Severe Inducement”. The maximum duration is limited to 30 minutes in each restoration operation, and 3 operations are allowed, but “Temporary Restoration from Inducement” is turned off whenever the system advances to “Final Inducement” even if either 30 minutes or 3 operations are not used up.

All the abnormalities of the Urea SCR system need to be corrected to regain another restoration capability.

If all the abnormalities of the Urea SCR system are not corrected when the system is in “Severe Inducement”, the system advances to “Final Inducement” in 1 hour after “Severe Inducement” started and engine speed will be fixed to low idle to disable practical machine operation. If the system advances to “Severe Inducement”, utilize “Temporary Restoration from Inducement” immediately.

Procedure to activate “Temporary Restoration from Inducement”.

1. Press F6 to display the “SCR Information” screen when the Standard screen is on, only when the Urea SCR system is in “Severe Inducement”.

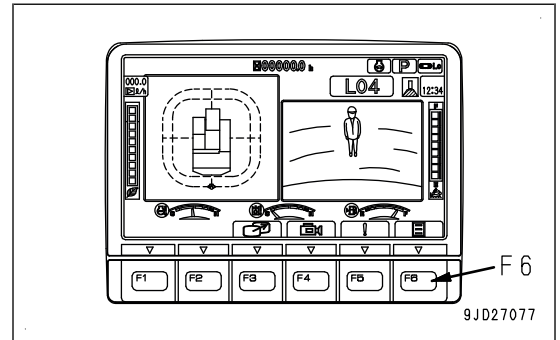

2. Press F6 to display the menu windows popping up in the bottom half of the “SCR Information”.

The menu windows popping up in the bottom half of the “SCR Information” screen alternate every 15 seconds as shown in the graphics A and B.

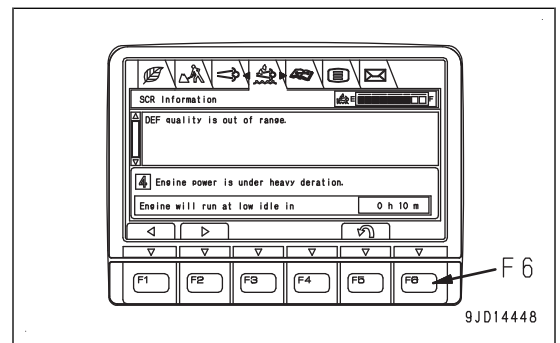

METHOD FOR CHECKING OIL LEVEL IN SWING MACHINERY CASE, ADDING OIL

WARNING

Immediately after the engine is stopped, its parts and oil are still very hot, and may cause burn injury. Wait for the temperature to go down, and then start the work.

1. Remove the dipstick (G) and wipe off oil on it with a cloth.
2. Insert the dipstick (G) fully into the dipstick pipe.

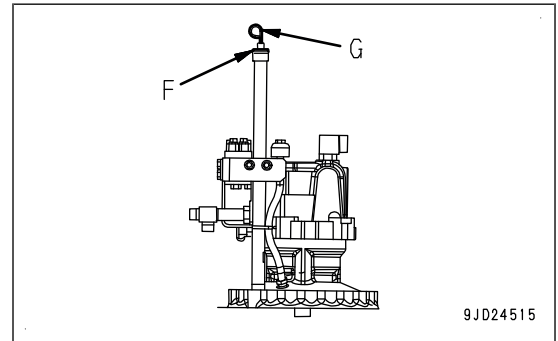

3. Pull out the dipstick (G) and check that the oil level is between the (H) and (L) marks on the dipstick.

If the oil level is below (L) mark, add oil through the oil filler port (F).

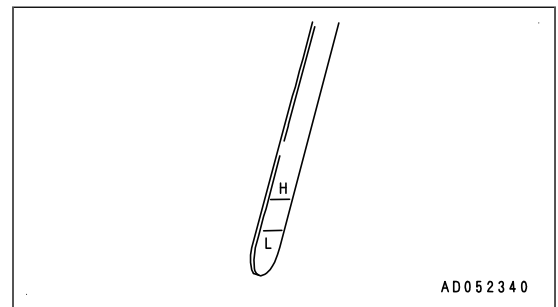

4. If the oil level is above the mark (H) of dipstick (G), install the hose (1) which has been stored in the toolbox to the drain valve (P) on the lower side of the machine. Loosen the drain valve (P) slowly to drain the excessive oil.
5. After checking the oil level or adding the oil, insert the dipstick (G) into the dipstick pipe.

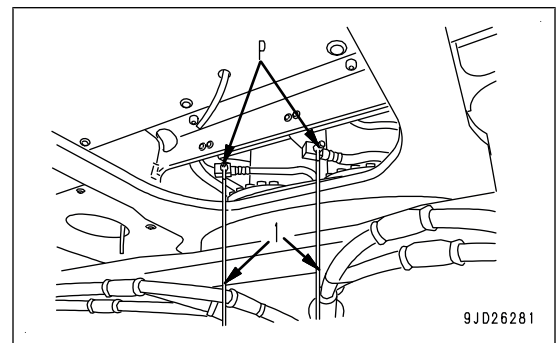

METHOD FOR CHECKING OIL LEVEL IN PTO GEAR CASE, ADDING OIL

WARNING

Immediately after the engine is stopped, its parts and oil are still very hot, and may cause burn injury. Wait for the temperature to go down, and then start the work.

NOTICE

Park the machine on a flat ground and stop the engine. When more than 30 minutes elapse after stopping the engine, check the oil level.

CLICK HERE TO **DOWNLOAD** THE COMPLETE MANUAL

- Thank you very much for reading the preview of the manual.
- You can download the complete manual from: www.heydownloads.com by clicking the link below



- Please note: If there is no response to CLICKING the link, please download this PDF first and then click on it.

CLICK HERE TO **DOWNLOAD** THE COMPLETE MANUAL

Height of the armrest can be adjusted up or down by using the knob at the rear of the armrest.

Armrest height adjustment: 43 mm (4 steps)

1. Loosen knob (1) at the rear of the armrest.
2. Pull plunger (2).

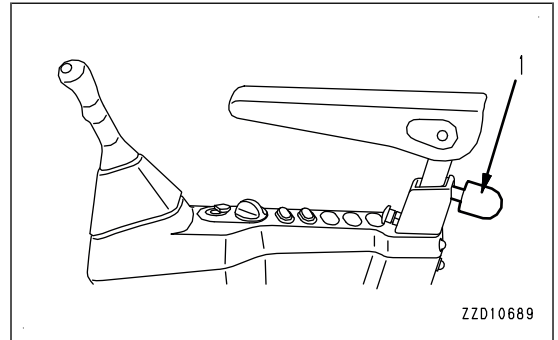

3. Adjust the height of armrest (3) while pulling plunger (2).
4. Push back plunger (2) after aligning it to the height adjustment hole of armrest (3).
5. Tighten knob (1) at the rear of the armrest.

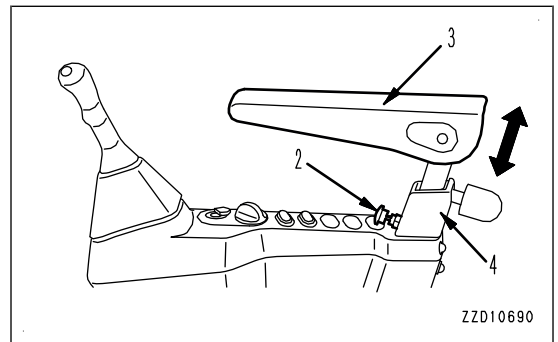

NOTICE

If you loosen knob (1) at the rear of the armrest too much, it touches the stopper in cover (4) and you cannot adjust the armrest height. Take care.

METHOD FOR ADJUSTING ARMREST ANGLE

Angle of the armrest can be adjusted vertically by turning adjustment dial (7) at the bottom of the armrest (5).

Angle adjustment: 9° in lower direction, 4° in upper direction

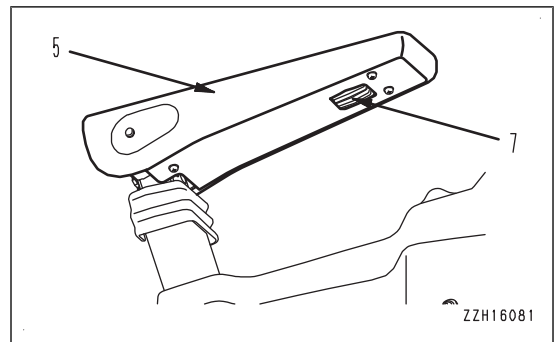

METHOD FOR ADJUSTING SEAT UNIT IN FORE-AND-AFT DIRECTION

Operate the fore-aft adjustment lever (8) to the right, and set the seat to the desired position, then let go of the lever.

The operator's seat, right and left control levers, and lock lever move together.

Fore-and-aft adjustment: 180 mm (9 steps)

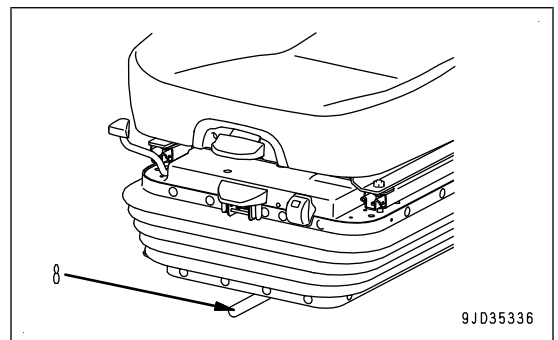

METHOD FOR ADJUSTING AIR SUSPENSION SEAT HARDNESS

Air suspension seat (if equipped)

Adjust the mirror so that you can see a person at the rear right end of the machine.

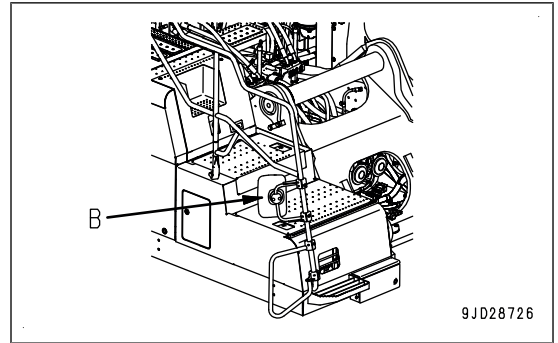

1. Adjust the mirror with your hand so that the side of the machine is reflected in the mirror as shown in the figure.
2. Check that you can see a person at the rear right end of the machine, at a 1.2 m height and a distance of 1.0 m from the edge of the machine.

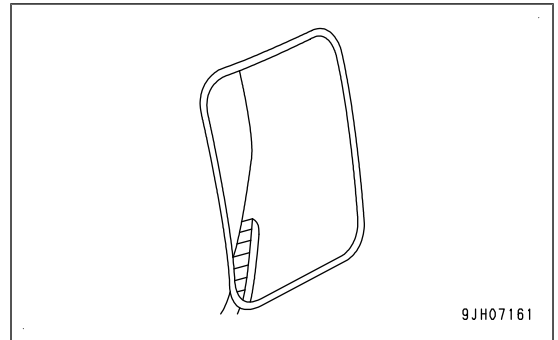

3. If you cannot adjust, loosen the mounting bolt (1) of mirror and the mounting bolt (2) of stay, and adjust the angles.

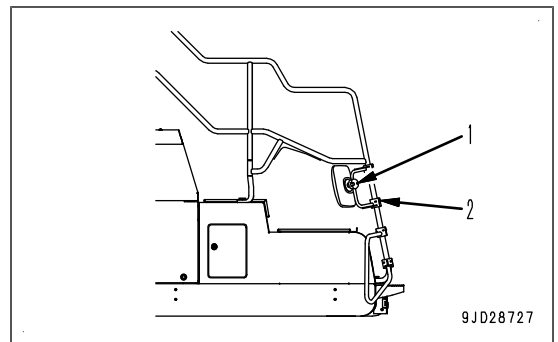

If the mirror is adjusted by loosening the mounting bolts, be sure to adjust the mirror to its regular position. For the adjustment method, see "PROCEDURE FOR ADJUSTING REGULAR POSITION OF MACHINE RIGHT FRONT MIRROR (B)".

PROCEDURE FOR ADJUSTING REGULAR POSITION OF MACHINE RIGHT FRONT MIRROR (B)

CAUTION

The following conditions must be met before starting the work to prevent the machine from moving during the work.

- The machine is placed on a level ground.
- The work equipment is lowered to the ground in secure posture.
- The lock lever is in LOCK position.
- The engine is stopped.

When returning the mirror to its regular position, perform the following adjustment.

METHOD FOR CHECKING LOW-SPEED RUN AND ACCELERATION OF ENGINE

CAUTION

- Perform these checks in a safe place, watching out for danger in the surroundings.
- When the engine performs very badly at low idle and in the acceleration and if that condition continues, it may damage the engine or confuse the operator's sense of driving or lower the braking efficiency, and as a result lead to an unexpected accident. In that case, ask your Komatsu distributor to check the engine as soon as possible.

- When stopping the machine during the normal travelling operation, check that the engine does not hunt or stop suddenly.
- Check that the engine speed rises smoothly when the fuel control dial is turned to High idle (MAX) position.

REMARK

- The smell of the exhaust gas is different from that of the conventional diesel engine because of the exhaust gas filtering function.
- White smoke may be discharged for a short time immediately after the engine is started or during the after-treatment devices regeneration in the cold season, but this is not a failure.
- When the hydraulic oil temperature is low, the engine speed and engine output at high idle are set to low to protect the components. When the hydraulic oil temperature becomes proper level, the engine speed and engine output at high idle are raised and the machine operates normally.

METHOD FOR RUNNING-IN THE NEW MACHINE

NOTICE

Your Komatsu machine has been thoroughly adjusted and tested before shipment from the factory. However, operating the machine under full load before breaking the machine in can adversely affect the performance and shorten the machine life.

Be sure to break in the machine for the initial 100 hours (as indicated on the service meter).

Make sure that you fully understand the descriptions in this manual, then run in the machine while paying attention to the following points.

- Run the engine at idle for 15 seconds immediately after starting it up. Do not operate the control levers or fuel control dial during this time.
- Perform warm-up operation for 5 minutes after the engine is started.
- Avoid operation with heavy loads or at high speeds.
- Immediately after starting the engine, avoid sudden starts, sudden acceleration, unnecessary sudden stops, and sudden changes in direction of the machine.

METHOD FOR ENGINE WARM-UP OPERATION

NOTICE

- Do not accelerate the engine abruptly until it is warmed up.
- Do not run the engine at low idle or high idle under no load for more than 20 minutes. This will have an adverse effect on the environment and also on the internal structure of the engine. If it is necessary to run the engine at idle for 20 minutes or more, apply a load from time to time or run at a medium speed.

This machine is equipped with an automatic engine warm-up system, so if the engine coolant temperature is 30 °C or less after the engine is started, the engine warm-up operation starts automatically. When the engine automatic warm-up operation starts, the engine speed is maintained higher than the normal speed at low idle.

If the engine coolant temperature goes 30 °C or more or if the warm-up operation is continued for more than 10 minutes, the automatic warm-up operation is cancelled and the engine speed drops to the normal speed at low idle.

Do not start operating the machine immediately. First, perform the following operations and checks.

REMARK

- When the key in starting switch (1) is turned to OFF (A) position, the engine stops, but the machine's main power supply is not turned off immediately. This is because that the power is supplied for the controller to save the operating condition and then finish the system. The time to keep supplying the power depends on the operating condition.
- Also when the cooling fan is used for a cleaning purpose, the machine's main power supply is not turned off immediately, even if the key in starting switch (1) is turned to OFF (A) position. This is for protection of the hydraulic circuit, and the power is kept supplied for 7 seconds.
- If the starting switch key (1) is turned to OFF (A) position while the engine is still hot, guidance (2) may be displayed on the machine monitor. This may cause damage to the devices. To cool down the engine gradually before stopping, run it at low idle for approximately 5 minutes.
- After the engine is stopped, DEF in DEF injector and pump is automatically purged and returned to the tank to prevent malfunction of the devices caused by freezing of DEF or deposition of urea. The devices continue the operation for maximum 7 minutes for this reason after the starting switch key is turned to OFF position, and this does not indicate abnormality. Do not turn the battery disconnect switch to OFF position while the devices are purging DEF. After the purging operation is finished, the devices stop automatically.

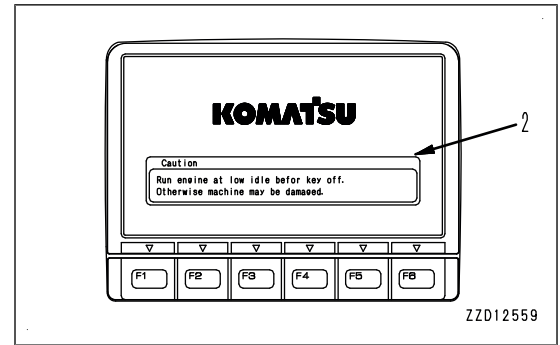

PROHIBITED OPERATIONS

WARNING

- Do not operate the work equipment control lever when the machine is travelling.
- If any lever is operated when the auto-deceleration is being actuated, the engine speed will suddenly increase, so be careful when operating.

PROHIBITION OF OPERATIONS USING SWING FORCE

Do not use the swing force to compact soil or break objects. This is not only dangerous, but also drastically reduces the life of the machine.

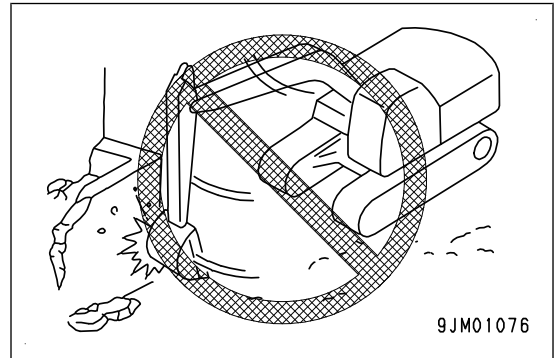

PROHIBITION OF OPERATIONS USING TRAVEL FORCE

Do not use the travel force to perform excavation by digging the bucket into the ground. This damages the machine or work equipment.

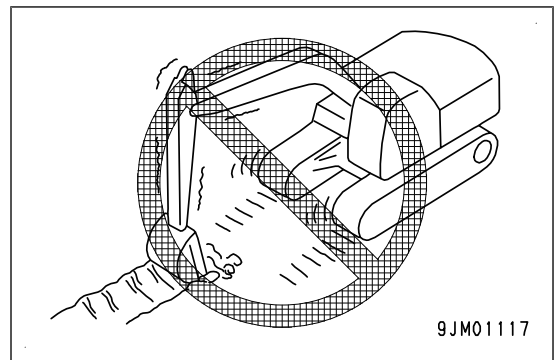

PROHIBITION OF OPERATIONS USING HYDRAULIC CYLINDERS TO STROKE END

If the work equipment is used with the cylinder rod operated to its stroke end, and given impact by some external force, the hydraulic cylinders may be damaged, causing personal injury. Do not perform operations with the hydraulic cylinder fully retracted or fully extended.

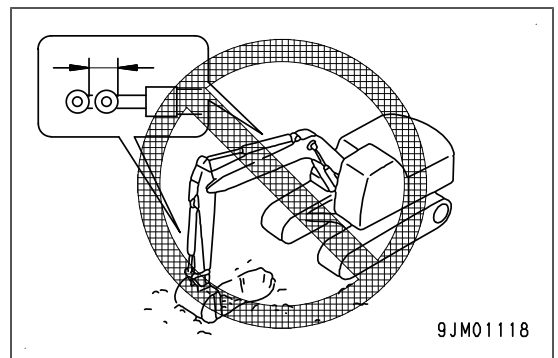

METHOD FOR REPLACING AND INVERTING BUCKET

⚠ WARNING

- When pins are knocked in with a hammer, pieces of metal may fly and cause serious injury. When performing this operation, always wear protective eyeglasses, hard hat, gloves, and other protective equipment.
- Place the removed bucket in a stable condition.
- The pin is hit with a strong force to remove, so the pin may fly out and injure people in the area around the machine. Make sure that there is no one in the area around the machine before starting the work.
- When pulling out the pins, do not stand behind the bucket. In addition, take extreme care not to put your foot under the bucket since the bucket may fall and cause serious injury.
- When removing or inserting pins, be extremely careful not to get your fingers caught.
- Never insert your fingers into the pin holes when aligning the holes.

Stop the machine on a firm and flat surface and do the work. When performing joint work, appoint a leader and follow that person's instructions and signals.

METHOD FOR CHANGING BUCKET

⚠ WARNING

- When pins are knocked in with a hammer, pieces of metal may fly and cause serious injury. When performing this operation, always wear protective eyeglasses, hard hat, gloves, and other protective equipment.
- Place the removed bucket in a stable condition.
- The pin is hit with a strong force to remove, so the pin may fly out and injure people around the machine. Make sure that there is no one around the machine before starting the work.
- When pulling out the pins, do not stand behind the bucket. In addition, take extreme care not to put your foot under the bucket since the bucket may fall and cause serious injury.
- Do not get your fingers caught when removing or inserting pins.
- Never insert your fingers into the pin holes when aligning the holes.

Stop the machine on a firm and flat surface and do the work. When performing joint work, appoint a leader and follow that person's instructions and signals.

1. Lower the bucket to the flat surface of the ground.

NOTICE

When removing the bucket, put the bucket cylinder downward as shown in the figure so that the front link (4) does not jump up due to the weight of the bucket cylinder (5).

REMARK

When removing the pins, place the bucket so that it is in light contact with the ground.

If the bucket is lowered strongly to the ground, the resistance will be increased and it will be difficult to remove the pins.

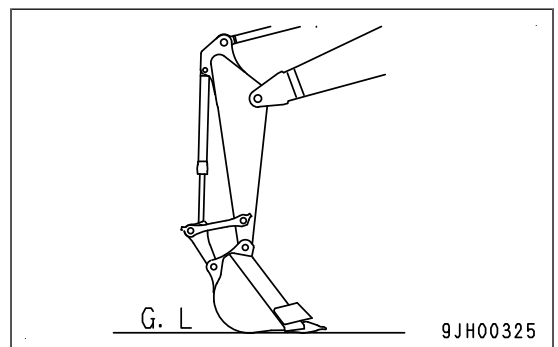

EXPLANATION OF AIR CONDITIONER EQUIPMENT

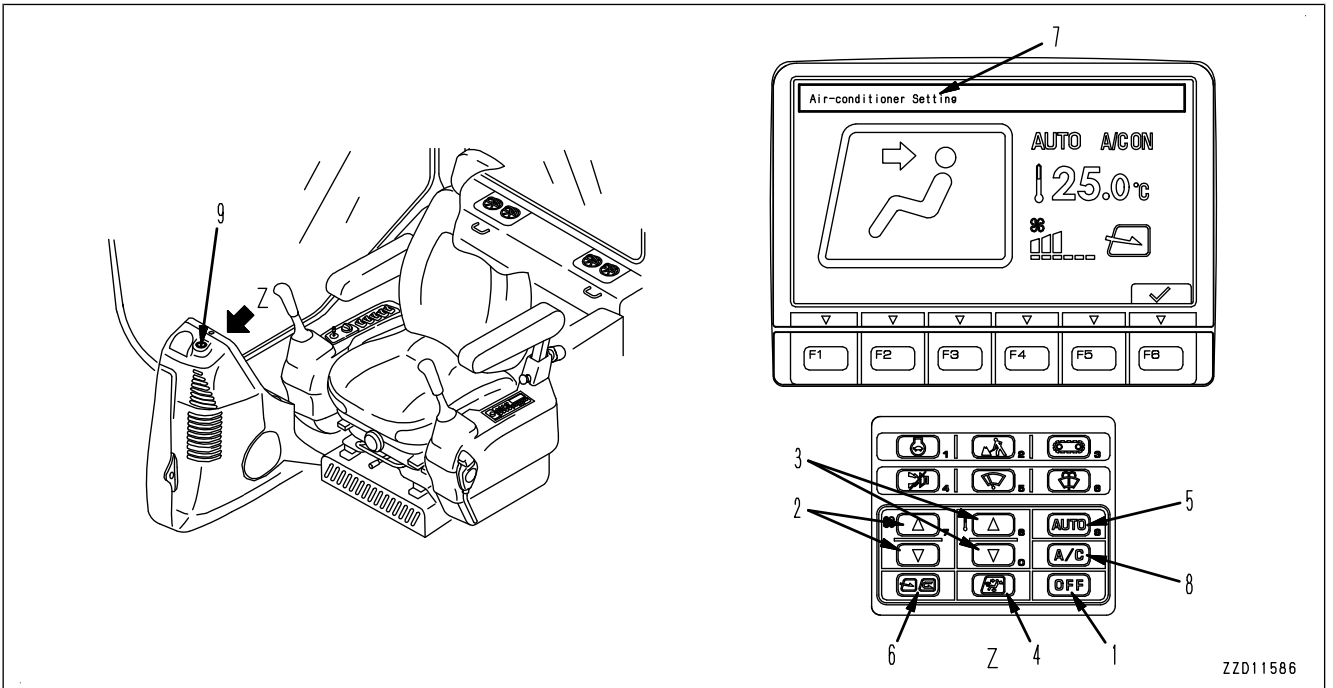

- (1) OFF switch
- (2) Fan switch
- (3) Temperature control switch
- (4) Vent selector switch
- (5) Auto switch
- (6) FRESH/RECIRC air selector switch
- (7) Display monitor
- (8) Air conditioner switch
- (9) Sunlight sensor

OFF SWITCH

This switch is used for stopping the fan and air conditioner.

REMARK

Even if this OFF switch is pressed, the monitor screen does not switch to the air conditioner adjustment screen.

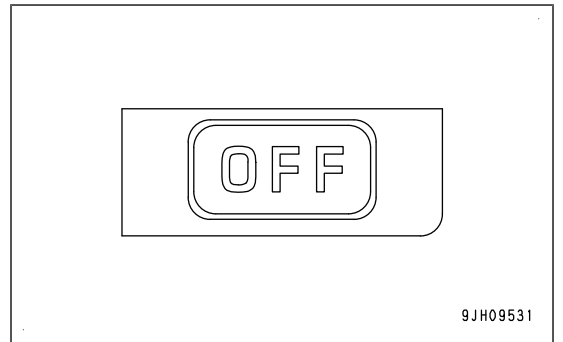

FAN SWITCH

You can adjust the air flow by using the fan switch.

The air flow can be adjusted to 6 levels.

- Press the Δ switch to increase the air flow; press the ∇ switch to decrease the air flow.
- During auto operation, the air flow is automatically adjusted.

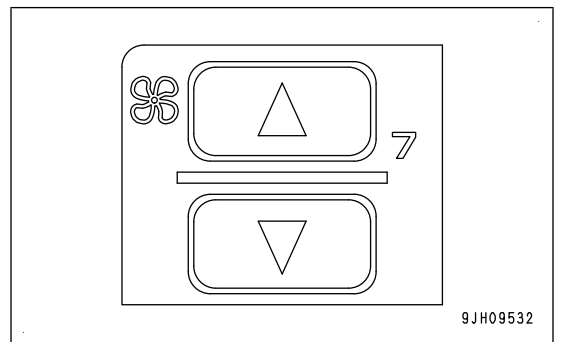

- Adjust fan switch (1), temperature control switch (4) and FRESH/RECIRC selector switch (5) to the desired positions.

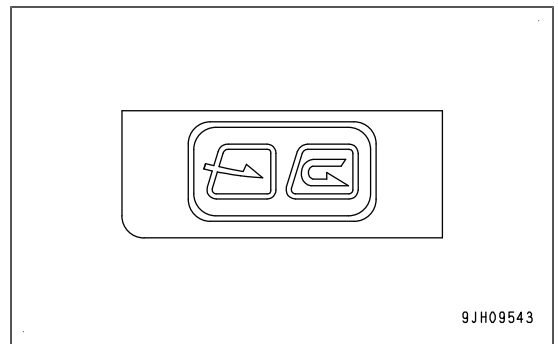
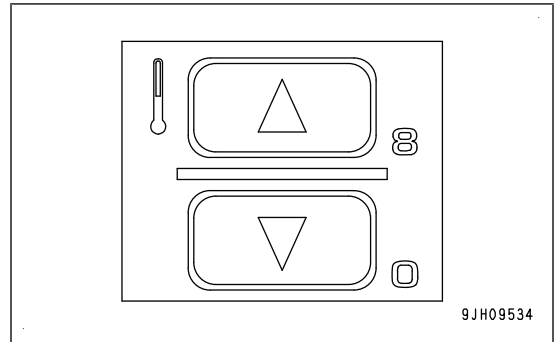
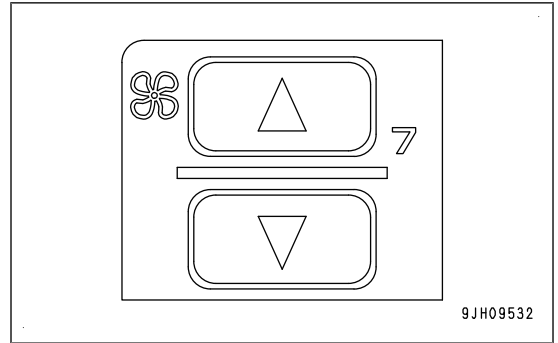

METHOD FOR OPERATING DEFROSTER

- Press fan switch (1) and adjust the air flow.

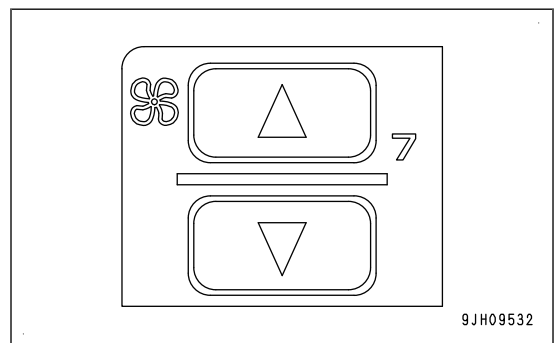
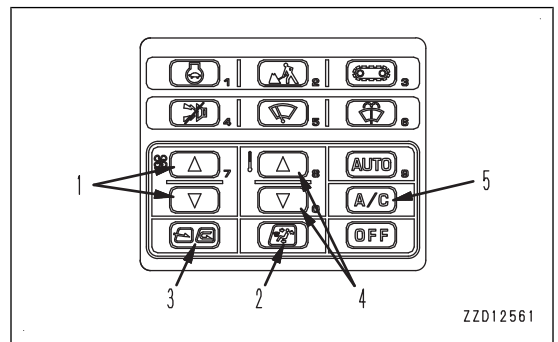

KomVision synthesizes the images of 4 cameras and displays the image from 300 ° above the machine.

The shaded area in the figure is not displayed on the monitor screen even if the camera images are synthesized.

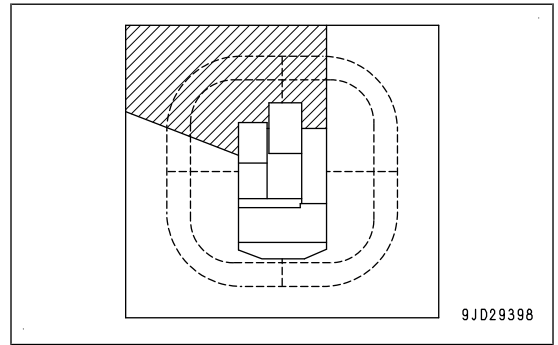

Since this image is electronically synthesized, the objects in the image may be displayed double or distortions or misalignment may occur in the shaded areas of the back of the machine (A) and (B) and the right of the machine (C).

For the camera image, the image shot by each of the loaded cameras is displayed.

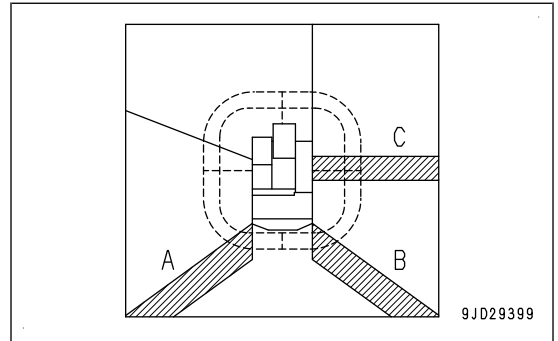

The guide line is displayed as follows:

Display area	Display colour
Quadrangle (A) in which the rear of the machine is inscribed when the machine swings	Red
Quadrangle + 2 m (B) in which the rear of the machine is inscribed when the machine swings	Yellow

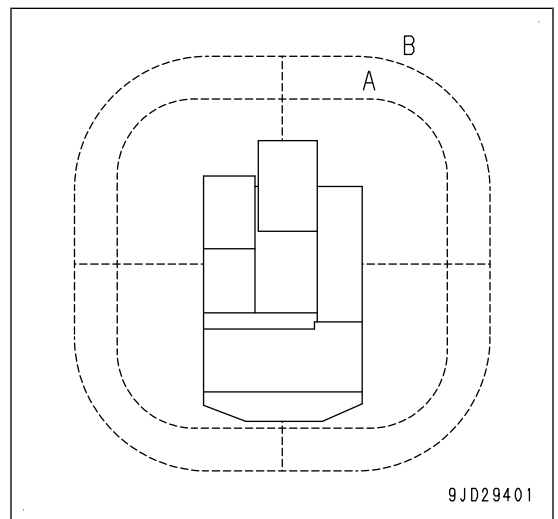

When the ambient temperature drops, the capacity of the battery will also drop. Maintain the battery charging rate as close as possible to 100 %. Insulate it against cold temperature to ensure that the machine can be started easily in the next morning.

REMARK

Measure the gravity of the electrolyte and calculate the charging rate from the following conversion table.

Electrolyte Temperature Charging Rate (%)	20 °C	0 °C	-10 °C	-20 °C
100	1.28	1.29	1.30	1.31
90	1.26	1.27	1.28	1.29
80	1.24	1.25	1.26	1.27
75	1.23	1.24	1.25	1.26

- When the ambient temperature is low, the capacity of the battery considerably drops. Cover it, or remove it from the machine to place it in the warm place. Restore it again before the operation.
- If the electrolyte level is low, add distilled water in the morning before beginning the work. Do not add water after the day's work to prevent diluted electrolyte in the battery from freezing during the night.

PRECAUTIONS AFTER DAILY WORK COMPLETION IN COLD WEATHER

⚠ WARNING

Performing idling of the tracks is dangerous, stay well away from the tracks.

To prevent mud, water, or the undercarriage from freezing and making it impossible for the machine to move on the following morning, observe the following precautions.

- Remove all the mud and water from the machine body. In particular, wipe the hydraulic cylinder rods clean to prevent damage to the seal caused by mud, dirt, or drops of water on the rod from getting inside the seal.
- Place the machine on a firm, dry ground.
If this is impossible, park the machine on boards.
The boards prevent the tracks from freezing to the ground, and allow the machine to move the next morning.
- Open the drain valve and drain any water collected in the fuel system to prevent it from freezing.
- Fill up the fuel tank. This minimizes moisture condensation in the tank when the temperature drops.
- In cold weather condition, add DEF to the defined level strictly. If adding more than the defined level, it may expand to break the devices in the tank when it freezes.
If DEF tank level is lower than the defined level for the cold weather, DEF may freeze easily to damage the parts in DEF system. If the filler cap freezes, defreeze and open.
- After operation in water or mud, remove water from undercarriage as described below to extend undercarriage service life.

Swing 90 ° with engine at low idle and bring the work equipment to the side of the track.

Slowly push up the machine until the track is raised slightly from the ground. Perform idle rotation of track. Perform this procedure on the right and left sides alternately.

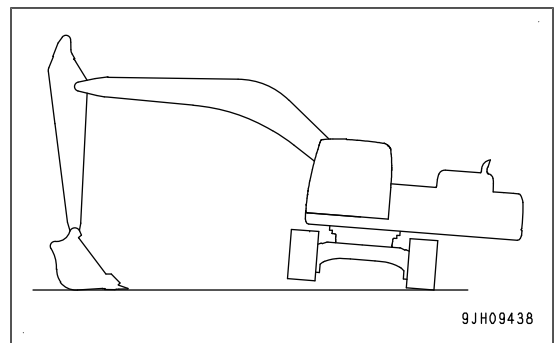

START ENGINE WITH JUMPER CABLES

⚠ WARNING

- When connecting the cables, never contact the positive (+) and negative (-) terminals.
- Always wear protective eyeglasses and rubber gloves when starting the engine by using the jumper cable.
- Be careful not to let the normal machine and failed machine contact each other.
The sparks caused near the battery could ignite the hydrogen gas generated from the battery, so be careful not to let it happen.
- Make sure that there is no mistake in the jumper cable connections. In the last connection (to the upper structure frame), a spark will be caused, connect the cable to a spot as far away from the battery as possible. (However, do not connect to the work equipment since the current does not flow well through it.)
- When disconnecting the jumper cable, take care not to bring the clips in contact with each other or with the machine.
- Do not ground by contact between the track shoes, because it may cause a spark in the swivel joint, etc.

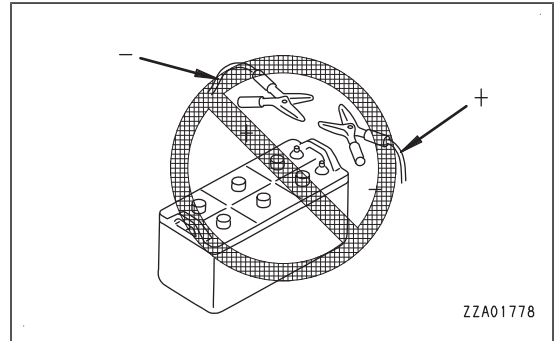

NOTICE

- The starting system for this machine uses 24 V. Accordingly, the normal machine must be equipped with a 24 V battery.
- The sizes of the jumper cables and clips should be suitable for the battery size.
- The battery of the normal machine must be the same capacity as that of the failed machine.
- Check the cables and clips for damage or corrosion.
- Make sure that the cables and clips are firmly connected.
- Check that the lock levers and parking brake levers (if equipped) of both machine are in LOCK position.
- Check that each lever is in NEUTRAL position.
- To prevent damage of the electric devices of the failed machine, turn the starting switch of the failed machine to OFF position, and then turn the battery disconnect switch key to OFF position before connecting the jumper cables.

PROCEDURE FOR CONNECTING JUMPER CABLE

Turn the starting switch and battery disconnect switch of the failed machine, and the starting switch of the normal machine to OFF position.

1. Connect the clip of jumper cable (A) to the positive (+) terminal of battery (C) on the failed machine.
2. Connect the clip at the other end of jumper cable (A) to the positive (+) terminal of battery (D) on the normal machine.
3. Connect the clip of jumper cable (B) to the negative (-) terminal of battery (D) on the normal machine.
4. Turn the battery disconnect switch (S) of the failed machine to ON position.

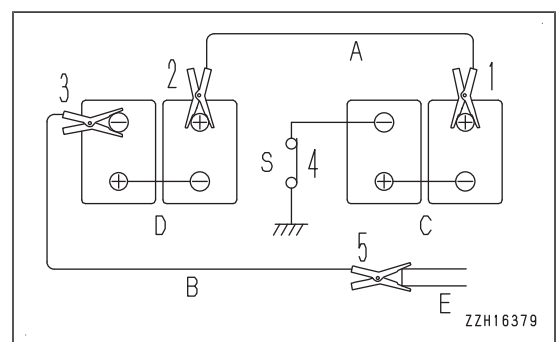

- Do not put unnecessary things in your pockets. Carry only things which are necessary for inspection.

PRECAUTIONS FOR KDPF

When performing inspection and maintenance during or just after regeneration, take care of the high temperature parts.

Even after the engine stops the parts around KDPF may be at high temperature.

PRECAUTIONS FOR SCR ASSEMBLY

Be careful for the high temperature parts when performing inspection and maintenance. Even after the engine stops the parts around SCR device may be at high temperature.

DUSTY JOBSITES

When working at dusty jobsites, observe the following.

- Clean the radiator fins and other parts of the heat exchange equipment more frequently, and take care not to let the fins become clogged.
- Replace the fuel filter more frequently.
- Clean electrical components, especially the starting motor and alternator, to avoid accumulation of dust.
- When checking and replacing the oil or filters, move the machine to a place where there is no dust and take care to prevent dust from entering the system.

AVOID MIXING OIL

Never mix different brand or grade of oil. If a different brand or grade of oil has to be added, drain the old oil and replace all the oil with the new brand or grade of oil.

LOCK INSPECTION COVERS

Lock inspection cover securely into position with the lock bar, etc. If inspection or maintenance is performed with inspection cover not locked in position, there is a danger that it may be suddenly shut by the wind and cause personal injury.

BLEED AIR FROM HYDRAULIC CIRCUIT

When hydraulic equipment is repaired or replaced, or the hydraulic piping is disconnected, the air must be bled from the circuit.

PRECAUTIONS WHEN INSTALLING HYDRAULIC HOSES

- When removing parts at locations where there are O-rings or gasket seals, clean the mounting surface, and replace them with new parts.
When doing this, be careful not to forget to assemble O-rings and gaskets.
- When installing the hoses, do not twist them or bend them sharply.
If they are installed so, their service life will be extremely shortened and they may be damaged.

CHECKS AFTER INSPECTION AND MAINTENANCE

Unexpected problems may occur if you do not perform the necessary inspection and maintenance. Always observe the following, otherwise it may lead to personal injury.

Checks after operation (with engine stopped)

- Have any inspection and maintenance points not been forgotten?
- Have all inspection and maintenance items been performed correctly?
- Have any tools or parts not dropped inside the machine? It is particularly dangerous if the parts drop inside the machine and get caught in the lever linkage mechanism.
- Isn't there any leakage of coolant or oil? Have all nuts and bolts been tightened?

Torque list for hoses

Tighten the hoses to the torque shown in the table.

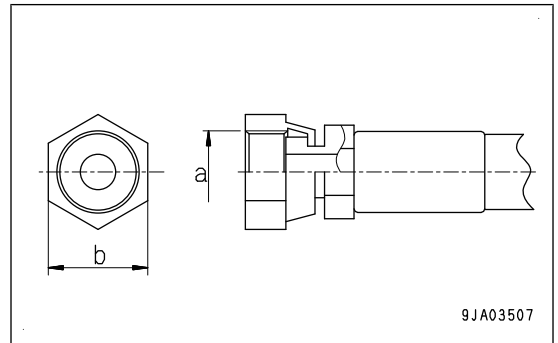

Taper seal

Nominal No. of hose	Thread size "a" (mm)	Width across flats "b" (mm)	Tightening torque					
			Target value			Allowable range		
			Nm	kgfm	lbft	Nm	kgfm	lbft
02	14	19	44	4.5	32.5	34 to 63	3.5 to 6.5	25.3 to 47
03	18	22	78	8.0	57.9	59 to 98	6.0 to 10.0	43.4 to 72.3
04	22	27	103	10.5	75.9	84 to 132	8.5 to 13.5	61.5 to 97.6
05	24	32	157	16.0	116	128 to 186	13.0 to 19.0	94 to 137
06	30	36	216	22.0	159	177 to 245	18.0 to 25.0	130 to 181
10	33	41	216	22.0	159	177 to 245	18.0 to 25.0	130 to 181

Face seal

Nominal No. of hose	Nominal size - threads per inch "a"	Width across flats "b" (mm)	Tightening torque					
			Target value			Allowable range		
			Nm	kgfm	lbft	Nm	kgfm	lbft
02	$\frac{9}{16}$ -18UN	19	44	4.5	32.5	34 to 54	3.5 to 5.5	25.3 to 39.8
03	$\frac{11}{16}$ -16UN	22	74	7.5	54.2	54 to 93	5.5 to 9.5	39.8 to 68.7
04	$\frac{13}{16}$ -16UN	27	103	10.5	75.9	84 to 132	8.5 to 13.5	61.5 to 97.6
05	1-14UNS	32	157	16.0	116	128 to 186	13.0 to 19.0	94.0 to 137.4
06	$1\frac{3}{16}$ -12UN	36	216	22.0	159	177 to 245	18.0 to 25.0	130.2 to 180.8

Komatsu machines are supplied with Non-Amine Engine Coolant (AF-NAC). Non-Amine Engine Coolant (AF-NAC) has excellent anti-corrosion, antifreeze and cooling properties and can be used continuously for 2 years or 4000 hours.

Komatsu recommends the use of Non-Amine Engine Coolant (AF-NAC). If you use another coolant, it may cause serious problems, such as corrosion of the engine and aluminum parts of the cooling system.

To maintain the anti-corrosion properties of Non-Amine Engine Coolant (AF-NAC), always keep the density of Non-Amine Engine Coolant between 30% and 64%.

Non-Amine Engine Coolant (AF-NAC) is already diluted with distilled water. When using the coolant, investigate the lowest temperature in the past and decide the density for the coolant from the coolant density table below.

When deciding the density for the coolant, set it for a temperature 10 °C below the actual lowest temperature in the working area.

The coolant density varies according to the ambient temperature, but it must be over 30% at least.

Coolant density table

Min. atmospheric temperature	°C	-10 or more	-15	-20	-25	-30	-35	-40	-45	-50
Density (%)		30	36	41	46	50	54	58	61	64

⚠ WARNING

- **Coolant is toxic. When opening the drain valve, be careful not to get coolant on you. If it gets in your eyes, flush your eyes with large amount of fresh water and see a doctor immediately.**
- **When handling the cooling water containing coolant that has been drained during changing the coolant or repairing the radiator, contact your Komatsu distributor or request a qualified company to perform the operation. Coolant is toxic, so never pour it into drainage ditches or drain it onto the ground surface.**

NOTICE

Komatsu recommends using genuine Non-Amine Engine Coolant (AF-NAC) for the coolant.

Non-Amine Engine Coolant (AF-NAC) is already diluted with distilled water, so it is not flammable.

Check the density with a coolant tester.

Prepare a container whose capacity is larger than the specified coolant volume to catch the drained coolant.

Clean the inside of the cooling system according to the following procedure.

1. Place the machine on a level ground, then stop the engine.
2. Remove the bolt, remove the cover (1), and check that the coolant temperature is low enough to touch the radiator cap surface by bare hand, turn the radiator cap (2) slowly until it hits the stopper, and release the pressure.
3. While pushing the radiator cap (2), turn it until it hits the stopper, then remove it.
4. Remove the covers (3), (4), (5), and set the containers under the coolant drain valves (6) and (7) on the lower side of the radiator and the engine coolant drain valve (8) on the upper side of the engine oil pan, to receive the coolant mixture.
5. Open the drain valves (6), (7), and (8) to drain the coolant.
6. After the coolant is drained, add the tap water. After the radiator is filled with water, start the engine, run it at low idle, raise the water temperature to 90 °C or higher, and run the engine for approximately 10 minutes.

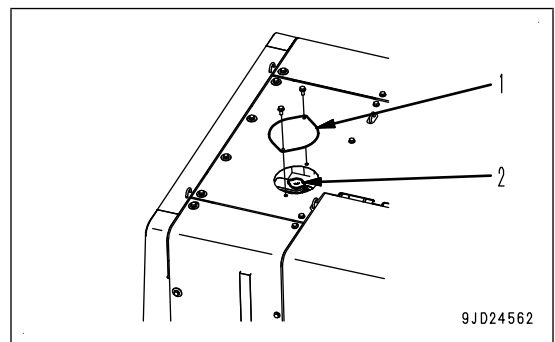

If the level of the refrigerant (gas) is low, the cooling effect will be reduced. Run the engine at high idle, and check the flow of the refrigerant gas (Hydrofluorocarbons HFC -134a) in the refrigerant circuit through the sight glass (2) (inspection window) of the receiver (1) when the cooler is running at high speed.

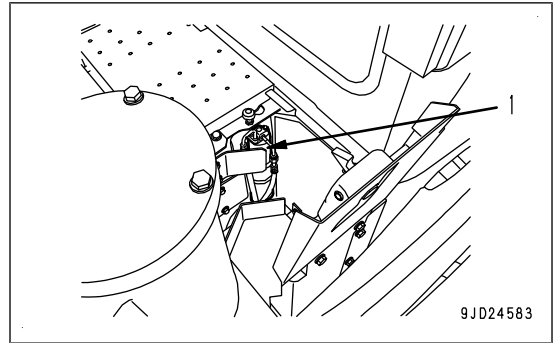

- (A) No bubbles in refrigerant flow: Suitable
- (B) Some bubbles in refrigerant flow (bubbles pass continuously): Insufficient
- (C) Colourless, transparent: No refrigerant

REMARK

When there are bubbles, the refrigerant gas level is low. Contact your Komatsu distributor to have refrigerant added. If the air conditioner is operated with the refrigerant gas level low, it will cause damage to the compressor.

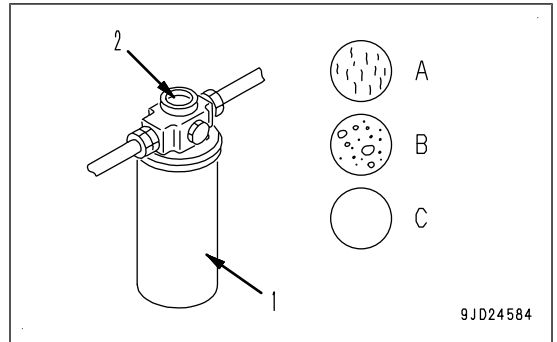

METHOD FOR REPLACING ADDITIONAL FILTER ELEMENT FOR BREAKER

(if equipped)

⚠ WARNING

- **Immediately after the engine is stopped, its parts and oil are still very hot, and may cause burn injury. Wait for the temperature to go down, and then start the work.**

For the element replacement interval, see “MAINTENANCE INTERVAL FOR HYDRAULIC BREAKER”.

Items to be prepared

Container to catch the oil

1. Place a container to catch the drained oil under the filter element.

- (2) Boom foot pin (2 places)
- (3) Boom cylinder rod pin (2 places)
- (4) Arm cylinder foot pin (1 place)

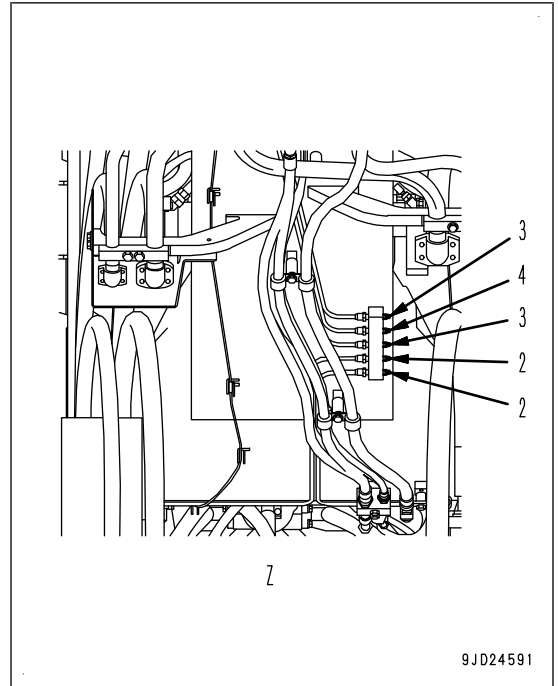

- (5) Boom and arm connection pin (1 place)
- (6) Bucket cylinder foot pin (1 place)
- (7) Arm cylinder rod pin (1 place)

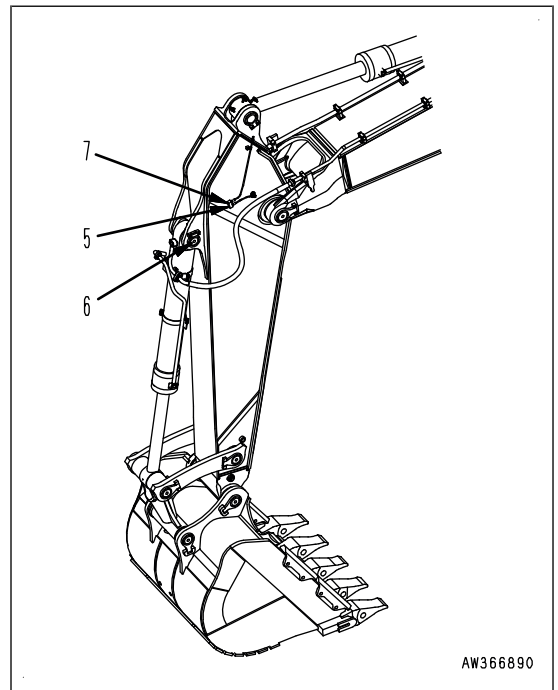

- (8) Arm and link connection pin (1 place)
- (9) Arm and bucket connection pin (1 place)

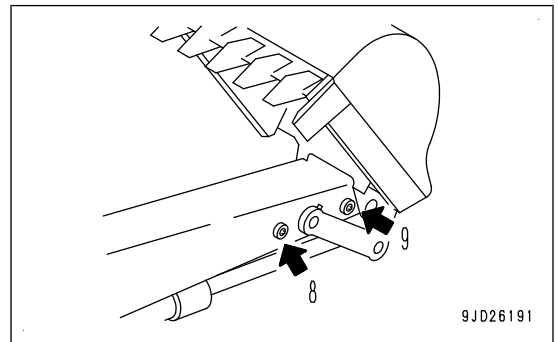

METHOD FOR CLEANING RECIRCULATION AIR FILTER

1. Remove wing bolts (1) from the inspection window at the bottom rear left inside the operator's cab.
2. Take out the recirculation air filter.
3. Clean the filter with compressed air.

If there is oil on the filter, or if the filter is extremely dirty, wash it in a neutral detergent. After rinsing it in water, dry it thoroughly before using it again.

Replace the filter with a new one every year. If the clogging of the filter cannot be removed by blowing with air or washing in water, replace the filter immediately.

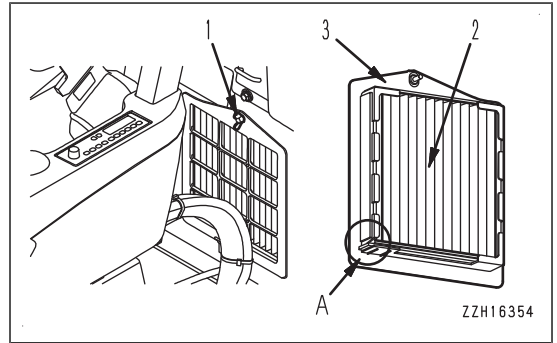

REMARK

- The recirculation air filter must be installed in the correct direction.
 - Install the filter so that protrusion (A) of filter (2) matches the groove of holder (3).
4. Install the recirculation air filter.

METHOD FOR CLEANING FRESH AIR FILTER

1. Unlock cover (4) at the rear left of the operator's cab with the starting switch key.
2. While holding cover (4) open, remove filter (5) inside it.

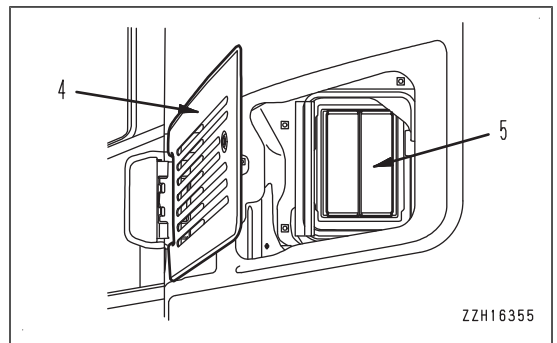

REMARK

- When removing, insert your finger into dent (D) of duct (6) and pull it toward you. If you grasp the filter with excessive force, it may be deformed or damaged.
- If the filter is damaged or deformed, replace it with new one.

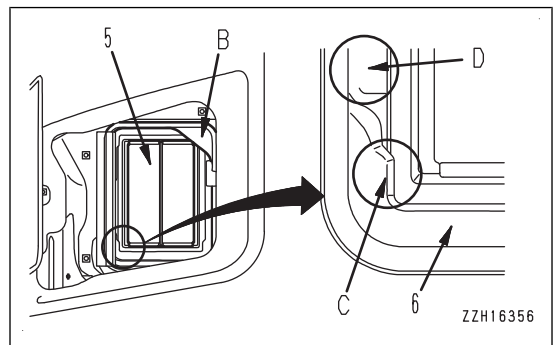

3. Clean the filter (5) with compressed air. Set the compressed air pressure below 0.49MPa{5kgf/cm²} and blow it in the arrow direction.

If there is oil on the filter, or if the filter is extremely dirty, wash it in a neutral detergent. After rinsing it in water, dry it thoroughly before using it again.

Replace the filter with a new one every year. If the clogging of the filter cannot be removed by blowing with air or washing in water, replace the filter immediately.

If the filter is damaged or deformed, replace it with new one.

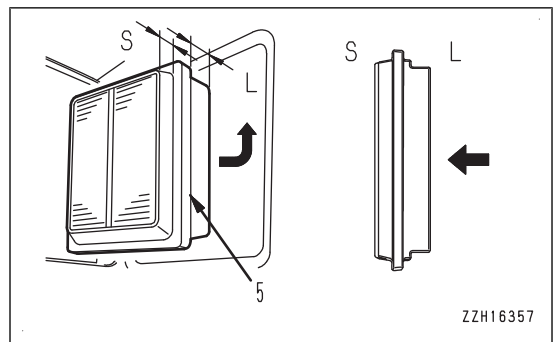

4. After cleaning, return filter (5).

1. Remove the nut (2) of breather assembly (1) (2 pieces) on top of the hydraulic tank, then remove the cover (3).

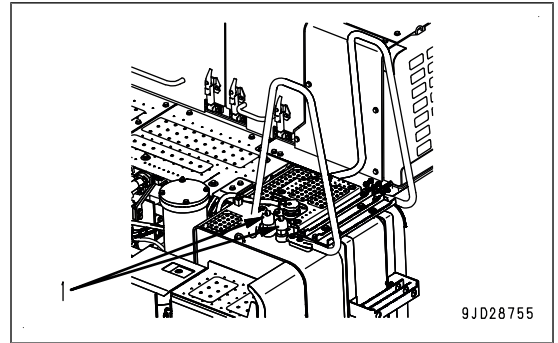

2. Replace the filter element (4) with a new one.
3. Install the cover (3) and nut (2).
Tightening torque: 10 to 14 Nm {1.0 to 1.4 kgfm}

NOTICE

If the breather assembly (1) is removed for replacement, apply a tool to the bolt (5) and tighten it.
Tightening torque: 68 to 78 Nm {6.93 to 7.95 kgfm}

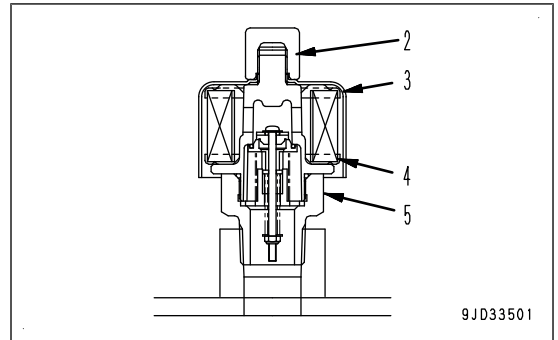

METHOD FOR REPLACING DEF TANK BREATHER ELEMENT

⚠ WARNING

Do not replace the element immediately after engine is stopped.

NOTICE

- Komatsu recommends using Komatsu genuine parts for replacement parts.
- If the machine is operated without DEF tank breather element attached, or with the element other than Komatsu genuine parts, foreign materials may enter into DEF pump and DEF injector which will cause failure of the machine. Never operate the machine without DEF tank breather element attached, nor use the element other than Komatsu genuine parts.
- Do not flush DEF tank breather element. Flushing or regenerating of it will degrade the performance of element, and will cause the breakage of DEF tank. Never reuse the DEF element.
- Always stop the engine and clean around DEF tank before replacing.
- After the engine is stopped, DEF system devices automatically purge DEF in DEF injector and DEF pump and return it to DEF tank to prevent malfunction of the devices caused by freezing of DEF or deposition of urea.
After the engine is stopped, the devices are operated for a few minutes. Replace the element after DEF system devices stop.
- Improper assembly of DEF tank breather element may cause leakage of DEF. Replace the element in the correct procedure.

1. Open DEF tank cover at the right of the machine upward.

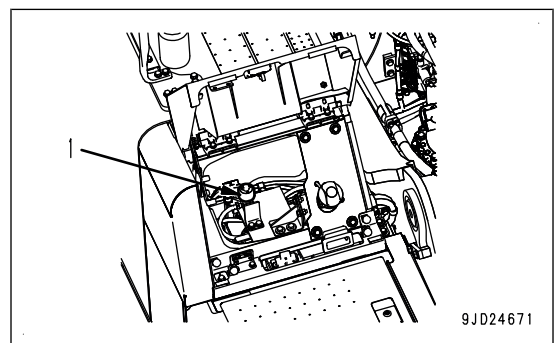

METHOD FOR REPLACING DEF FILTER

⚠ WARNING

Immediately after the engine is stopped, the parts are still very hot. Do not replace the filter immediately. Wait for all parts to cool down before starting the work.

NOTICE

- **Komatsu recommends using Komatsu genuine parts for replacement parts.**
- **If the machine is operated without the DEF filter attached, or with the filter other than Komatsu genuine parts, foreign materials may enter the DEF pump and DEF injector which will cause failure of the machine. Never operate the machine without the DEF filter attached, nor use the filter other than Komatsu genuine parts.**
- **The DEF filter cannot be flushed. Flushing or regenerating of it will degrade the performance of filter, and will cause the breakage of equipment. Never reuse the filter.**
- **Improper assembly of the DEF filter may cause leakage of the DEF. Replace the DEF filter in the correct procedure.**
- **DEF freezes at -11 °C. If it is frozen, replacement of the filter becomes difficult. Replace the filter when the temperature around DEF pump is higher than -11 °C, and in the condition that DEF is not frozen.**

After the engine is stopped, the DEF system devices automatically purge the DEF in the DEF injector and DEF pump and return it to the DEF tank to prevent malfunction of the devices caused by freezing of the DEF or deposition of urea.

After the engine is stopped, the devices are still operated for a few minutes. Before replacing the filter, clean around the DEF pump first after the DEF system devices stop.

Items to be prepared

- DEF filter removal tool

The DEF filter is located at the position shown in the figure.

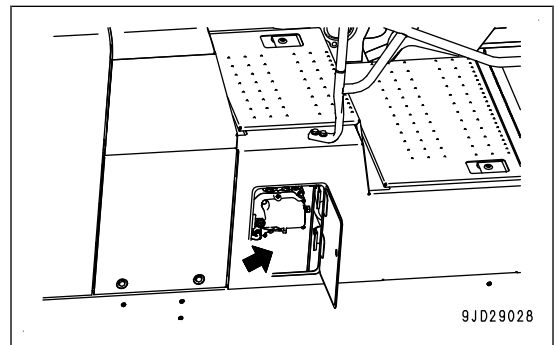

1. Remove the filter cap (1) at the bottom of DEF pump, and remove the element (2).

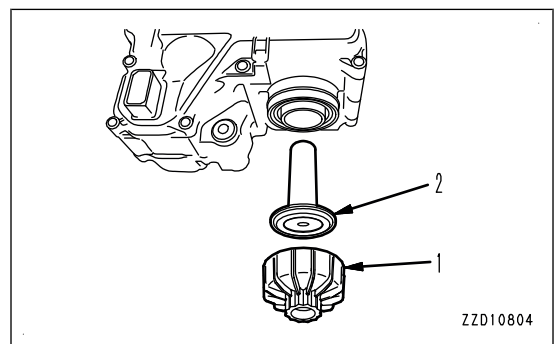

SPECIFICATIONS

HANDLE MACHINE READY FOR INSTALLATION OF ATTACHMENT

EXPLANATION OF COMPONENTS ON MACHINE EQUIPPED WITH ATTACHMENT

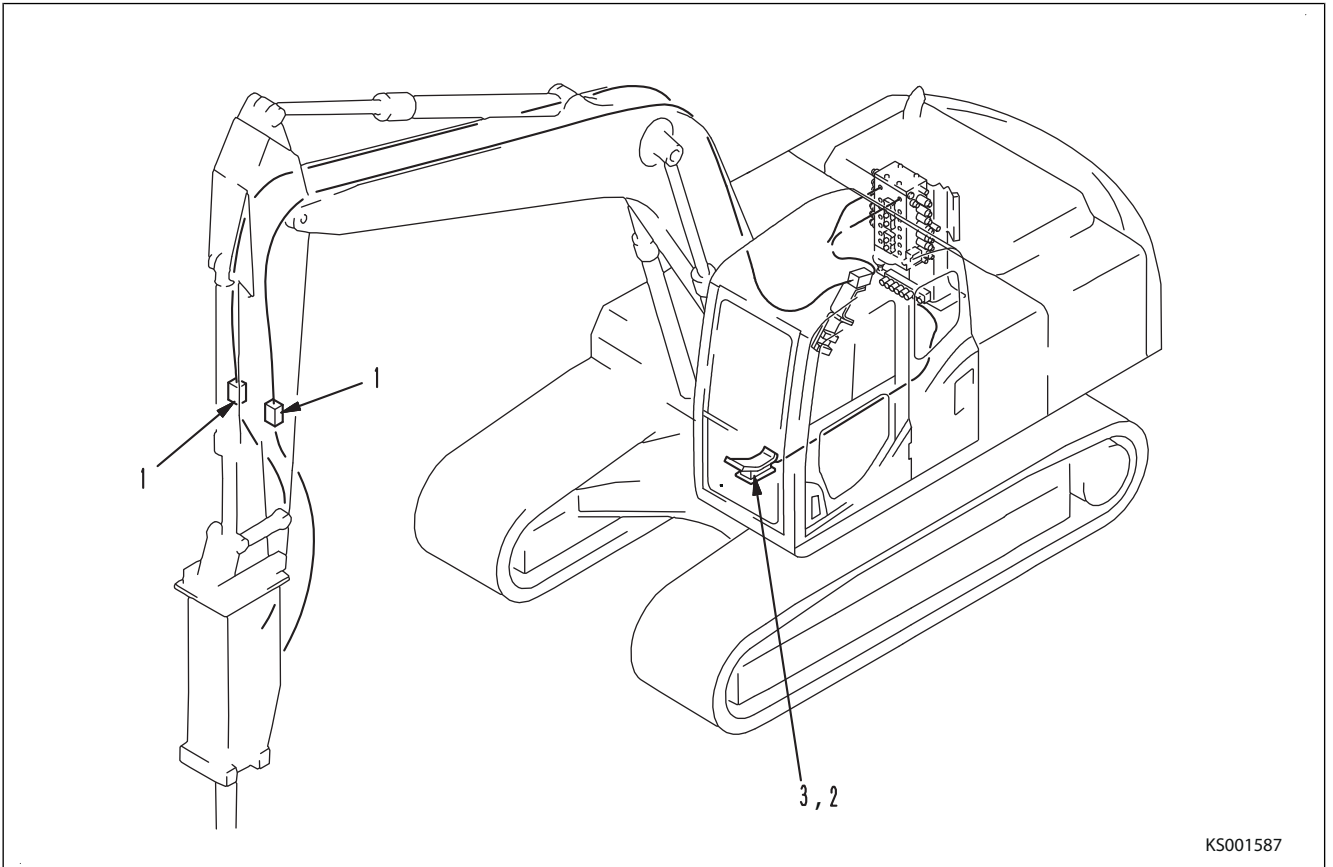

KS001587

(1) Stop valve

(2) Attachment control pedal (breaker)

(3) Lock pin

STOP VALVE

The stop valve stops the flow of the hydraulic oil.

(F) FREE

Hydraulic oil flows.

(L) LOCK

Hydraulic oil stops.

When removing or installing the attachments, set this valve to LOCK position.

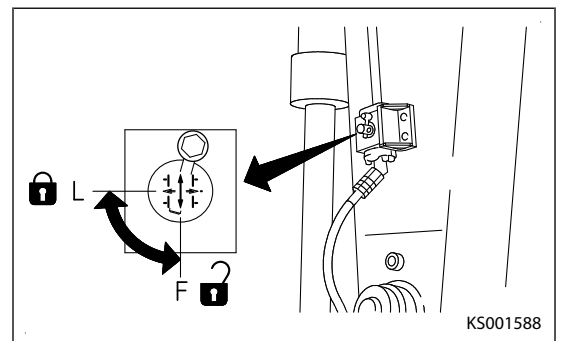

KS001588

Bucket 1.2 t/m ³	m ³ / kg	5.58 / 3925	4.28 / 3625	4.05 / 3250
Bucket 1.5 t/m ³	m ³ / kg	4.66 / 3650	3.59 / 3375	3.24 / 2600
Bucket 1.8 t/m ³	m ³ / kg	4.00 / 3425	3.10 / 3200	2.70 / 2175
Max Allowable Bucket Width mm	-	1910	1780	1600

Values shown are in accordance with EN474-5:2006+A1:2009 (E)

TRACK SHOES SELECTION

Select the appropriate track shoe to match the operating conditions.

Track shoe selection

Check the classification from the table of Classification by use, and select the shoe from the List of shoe specifications.

- Classification “B” is wide shoe whose usage is limited. Check the precautions for use and the using condition, and then use a suitable shoe.
- When selecting the shoe width, choose the narrowest shoes possible to bring the machine within the range where there is no problem regarding the machine flotation and ground contact pressure. If wider shoes than necessary are used, the load on the track shoes will increase. It may cause problems such as bending of the shoe, cracking of the link, damage of the pin, coming off of the pin and looseness of the shoe bolts.

Classification by use

	Use	Precautions when using
A	Rocky ground, river-beds Normal soil	Travel at low speed (Lo) on rough ground with large obstacles such as boulders or fallen trees.
B	Normal soil Soft ground	These shoes cannot be used on rough ground where there are large obstacles such as boulders or fallen trees. Use high-speed (Hi) on flat roads only. If you travel over an obstacle out of necessity, travel slowly at approximately 1/2 of low-speed (Lo).

List of shoe specifications

	PC700LC-11 E0	
	Specification	Classification
Standard	610 mm double	A
Optional	710 mm double	A
Optional	810 mm double	B

CLICK HERE TO **DOWNLOAD** THE COMPLETE MANUAL

- Thank you very much for reading the preview of the manual.
- You can download the complete manual from: www.heydownloads.com by clicking the link below



- Please note: If there is no response to CLICKING the link, please download this PDF first and then click on it.

CLICK HERE TO **DOWNLOAD** THE COMPLETE MANUAL