

Operation & Maintenance Manual

EEAM008402



PC450-6K

PC450LC-6K

HYDRAULIC EXCAVATOR

SERIAL NUMBERS PC450-6K - K30001 AND UP
PC450LC-6K - K30001



WARNING

Unsafe use of this machine may cause serious injury or death. Operators and maintenance personnel must read this manual before operating or maintaining this machine. This manual should be kept near the machine for reference and periodically reviewed by all personnel who will come into contact with it.

KOMATSU

CLICK HERE TO **DOWNLOAD** THE COMPLETE MANUAL

- Thank you very much for reading the preview of the manual.
- You can download the complete manual from: www.heydownloads.com by clicking the link below



- Please note: If there is no response to CLICKING the link, please download this PDF first and then click on it.

CLICK HERE TO **DOWNLOAD** THE COMPLETE MANUAL

MAINTENANCE

17. Guides to maintenance	3-2
18. Outlines of service	3-5
18.1 Outline of oil, fuel, coolant	3-5
18.2 Outline of electric system	3-9
18.3 Outline of hydraulic system	3-10
19. Wear parts list	3-11
20. Use of fuel, coolant and lubricants according to ambient temperature	3-12
21. Standard tightening torques for bolts and nuts	3-16
21.1 Introduction of necessary tools	3-16
21.2 Torque list	3-17
22. Periodic replacement of safety critical parts	3-18
23. Maintenance schedule chart	3-20
23.1 Maintenance schedule chart	3-20
23.2 Maintenance interval when using hydraulic breaker	3-22
24. Service procedure	3-23
24.1 When required	3-24
24.2 Check before starting	3-45
24.3 Every 50 hours service	3-49
24.4 Every 100 hours service	3-51
24.5 Every 250 hours service	3-54
24.6 Every 500 hours service	3-63
24.7 Every 1000 hours service	3-65
24.8 Every 2000 hours service	3-72
24.9 Every 4000 hours	3-79

SPECIFICATIONS

25. SPECIFICATIONS	4-2
25.1 Machine specifications	4-2
25.2 Explanation of lifting capacity chart	4-5

⚠ WARNING: Failure to follow these safety precautions may lead to a serious accident.

VENTILATION FOR ENCLOSED AREAS

- If it is necessary to start the engine within an enclosed area, provide adequate ventilation. Exhaust fumes from the engine can KILL.



PRECAUTIONS FOR MIRRORS, WINDOWS AND LIGHTS

- Remove all dirt from the surface of the windows and lights to ensure that you can see well.
- Adjust the rear view mirror so that you can see clearly from the operator's seat, and always keep the surface of the mirror clean. If any glass is broken, replace it with a new part.
- Check that the head lamps and working lamps are installed to match the operating conditions. Check also that they light up properly.

 **WARNING:** Failure to follow these safety precautions may lead to a serious accident.

OPERATION SUPERVISOR

- Before performing lifting operation, designate an operation supervisor. Always execute operation according to his instructions.
 - Execute operating methods and procedures under his direction.
 - Select a person responsible for signalling. Operate only on signals given by such person.

HANDLING OF WIRE ROPES ETC.

- Wear leather gloves when handling wire ropes.

HANDLING OF FLUIDS

- Some oils and other fluids, such as Antifreeze, can be harmful to you and the environment, you should therefore always follow the manufacturers instructions regarding storage, handling and disposal.

HANDLING OF USED ENGINE OILS

- Avoid contact with used engine oils.
- Refer to engine oils data sheet for handling and storage precautions.

HANDLING OF OILS

- For diesel oils, hydraulic oils and oils used in the swing machinery, PTO, transmission axles and hubs avoid prolonged or frequent contact with skin.
- Refer to manufacturers data sheet for handling and storage precautions.

HANDLING OF FLUIDS

- For antifreeze and grease refer to manufacturers data sheet for handling and storage precautions.

PROTECTING EYES

- Some oils and fluids can damage eyes. Refer to manufactured data sheet for handling and storage instructions.

1. Warnings for operation, inspection and maintenance

1. 2OE-00-K1170



- Improper operation and maintenance can cause serious injury or death.
- Read the manual and labels before operation and maintenance. Follow instructions and warnings in manual and in labels on machine.
- Keep the manual in machine cab near operator. If this manual is lost, please contact your Komatsu distributor for a replacement.



- Always apply lock when leaving operator's seat.

2. 2OE-00-KI230

Warnings when opening front window



- When raising window, lock it in place with lock pins on both sides.
- Falling window can cause injury.

3. 20Y-00-K2220

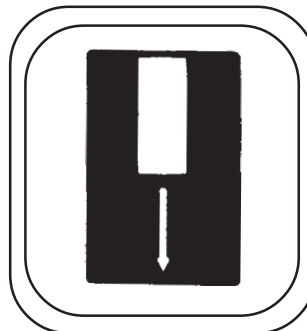

- Emergency exit
- Read operation manual before operation

3. HYDRAULIC OIL LEVEL

This warns that the hydraulic oil level is too low.
If the monitor lamp flashes, check the hydraulic oil level, and add oil.

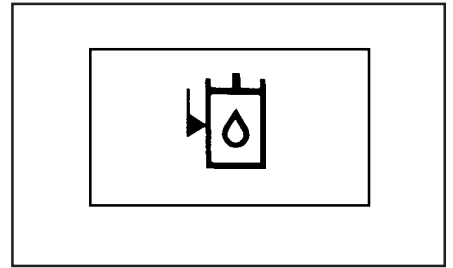

11.1.2 B: CAUTION ITEMS

⚠ CAUTION

If the caution monitor lamp flashes, repair the problem as soon as possible.

1. CHARGE LEVEL

This monitor indicates an abnormality in the charging system while the engine is running. If the monitor lamp flashes, check the V-belt tension. If any abnormality is found, see "16.6 OTHER TROUBLE".

REMARK

While the starting switch is ON, the lamp will remain lit and will go off once the engine is started.

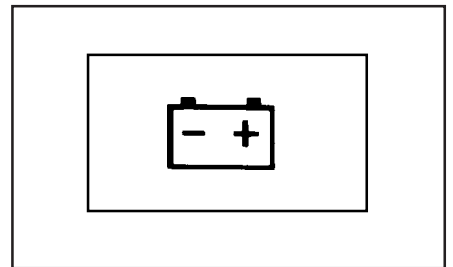

2. FUEL LEVEL

If the fuel drops below 55 litres (14.5 US gal, 12.2 UK gal), the lamp will flash. Top up the fuel before this.

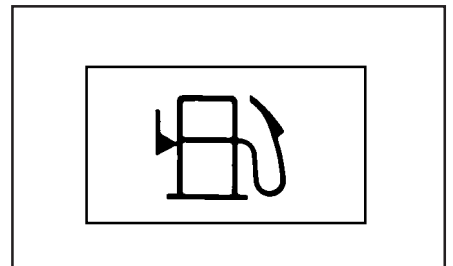

3. AIR CLEANER CLOGGING

This warns that the air cleaner is clogged.
If the monitor lamp flashes, stop the engine then inspect and clean the air cleaner.

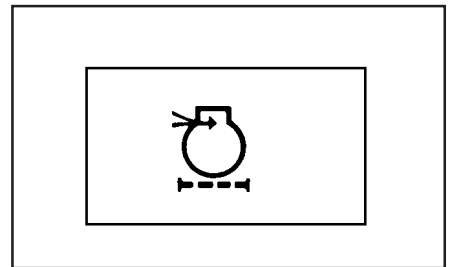

4. OVERLOAD CAUTION (When lifting)

This warns that the machine is close to tipping due to the load (an audible warning is also given), if the warning is given lower the load. Refer to the lifting capacity chart for safe load.

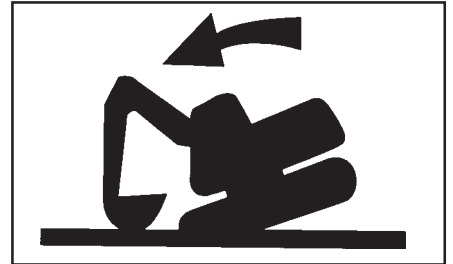

6. LAMP SWITCH

This switch turns on the working lamps and monitor illumination.

- ① OFF
- ② Standard work lamps
- ③ Standard and additional work lamps (if fitted)

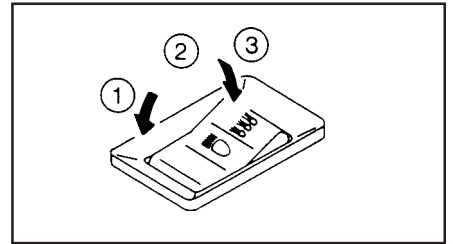

7. ALARM BUZZER STOP SWITCH

This is used to stop the alarm buzzer when it has sounded to warn of some abnormality in the EMERGENCY STOP ITEMS while the engine is running.

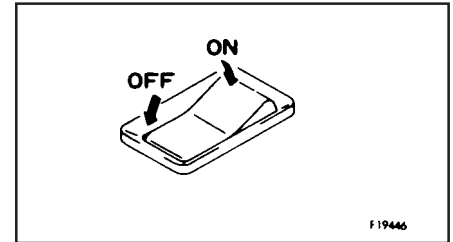

8. LOWER WIPER SWITCH (If fitted)

This switch actuates the front lower wiper.

OFF: wiper stops

ON: wiper moves continuously

NB. Do not operate with front lower screen removed.

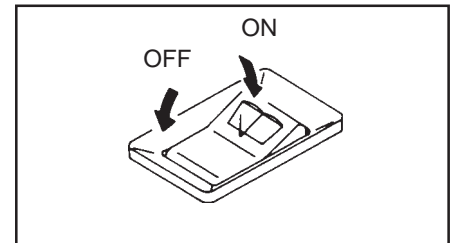

9. HORN BUTTON

When the button at the tip of the right work equipment control lever is pressed, the horn will sound.

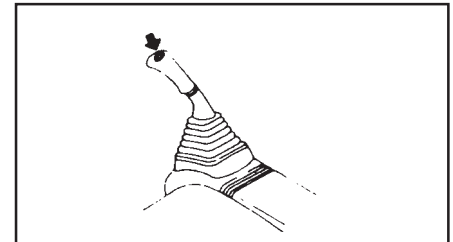

10. KNOB BUTTON

The button at the tip of the left work equipment control lever is used to actuate the power max./swift slow-down functions. Press the button once (single click) and keep it depressed. In the heavy-duty and general operation modes, the power max. function actuates for max. 8.5 seconds and the swift slow-down function actuates while the button is depressed.

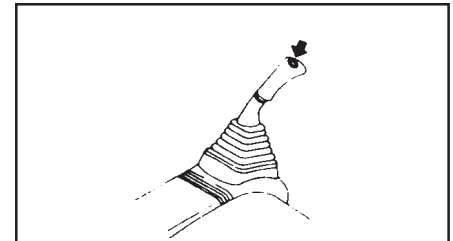

11. HEATED OPERATOR SEAT SWITCH (If fitted)

This switch is used to switch on the heated seat.

OFF: seat not heated

ON : seat heated

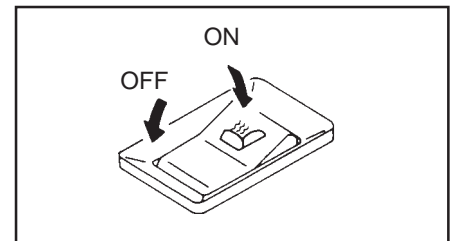

12. BEACON SWITCH (If fitted)

This switch is used to switch on the rotating beacon.

OFF

ON: beacon lights lights and rotates

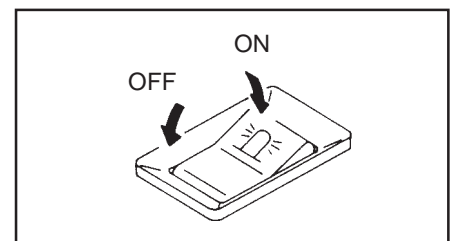

5. Lock securely with lock pins (A) at the left and right sides

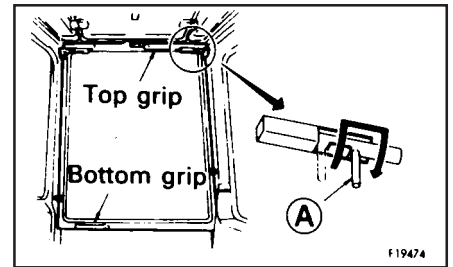

Removing front window (bottom)

Ensure lower wiper (if fitted) is in correct park position.

With the front window open, remove lock pins (E), and the bottom part of the front window can be removed.

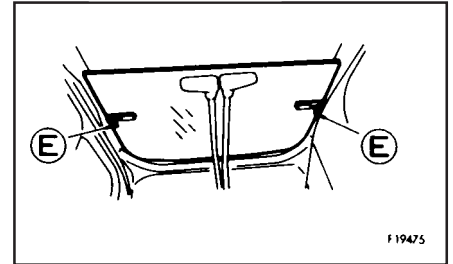

Store the removed bottom part of the front window at the rear of the operator's cab and lock with lock pins (E).

Notice

Do not operate lower wiper (if fitted) when front window (bottom) is removed.

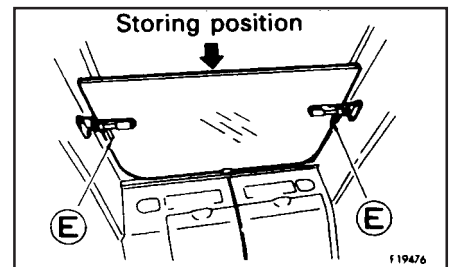

11.6 DOOR LOCK

Use the door lock to fix the door in position after opening it.

1. The door will become fixed in place when it is pressed against catch (1).
2. To release the lock, press knob (2) down at the left side of the operator's seat to release the catch.
When fixing the door, fix it firmly to the catch.

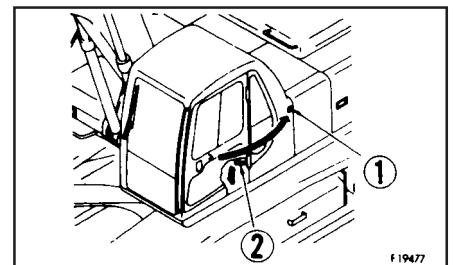

11.18.1 METHOD FOR RELEASING PRESSURE IN CONTROL CIRCUIT OF MACHINES EQUIPPED WITH ACCUMULATOR

1. Lower the work equipment to the ground. Close any attachment such as the crusher attachment jaws, etc.
2. Stop the engine.
3. Move the safety lock lever completely in the FREE position. Move the work equipment control lever and attachment control pedal full to the back and forth, right and left so as to release the pressure in the control circuit.
4. Move the safety lock lever to the lock position. Lock the control lever and attachment control pedal. The pressure, however, will not be completely released, so when the accumulator is removed in the control circuit, gradually loosen the screws. Never stand in the oil ejection direction.

After approx. 3 sec, the following gauges will remain on and the other monitors will go out.

- Engine water temperature gauge ⑩
- Fuel gauge ⑪

(2) Press lamp switch ⑮ to turn on the head lamps.

If the lamp switch do not light up, there is probably a broken bulb or disconnection in the wiring, so contact your Komatsu distributor for repairs.

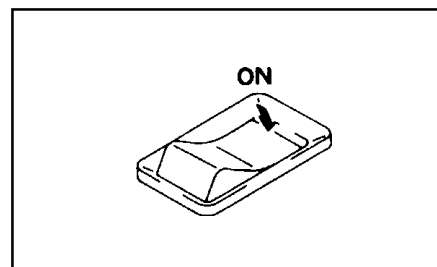

12.4 MOVING MACHINE OFF

12.4.1 MOVING MACHINE FORWARD

WARNING

- Before operating the travel levers, check the direction of the track frame. If the sprocket is at front, the operation of the track levers is reversed.
- When moving off, check that the area around the machine is safe, and sound the horn before moving.
- Clear all personnel from the machine and the area.
- Clear all obstacles from the path of the machine.
- If the lever is moved inside the deceleration range, engine speed will rise suddenly. Operate the levers carefully.

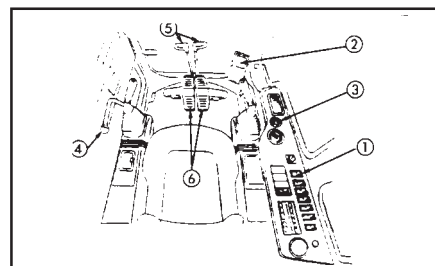

1. Set swing lock switch ① to the ON (actuated) position and confirm that swing lock monitor lamp ② lights up.

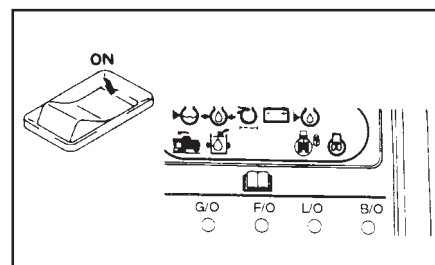

2. Turn fuel control dial ③ towards the full speed position to increase the engine speed.

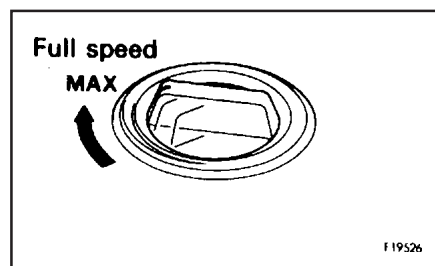

3. Set safety lock lever ④ in the FREE position, fold the work equipment, and raise it 40 - 50 cm (16 to 20 in) from the ground.

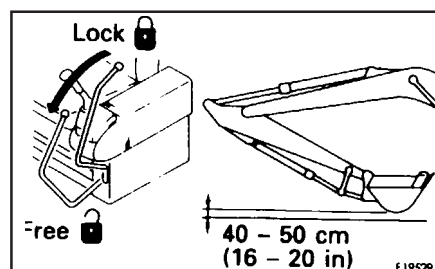

12.10 PROHIBITIONS FOR OPERATION

WARNING

- If it is necessary to operate the work equipment control lever when the machine is travelling, stop the machine before operating the work equipment control lever.
- If the lever is moved inside the deceleration range, engine speed will suddenly rise. Operate the levers carefully.
- Never operate the machine on a rock bed (hard or soft rock).

Prohibited operations using swing force

Do not use the swing force to compact soil or break earth mounds or walls.

When swinging, do not dig the bucket teeth into the soil. These operations will damage the work equipment.

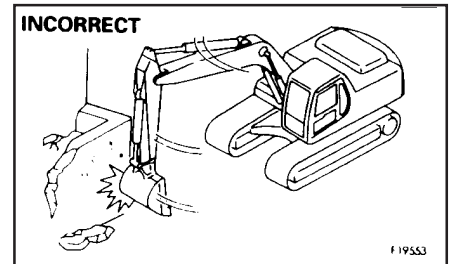

Prohibited operations using travel force

Do not leave the bucket dug into the ground and use the travel force to excavate. This will bring excessive force to bear on the rear of the machine.

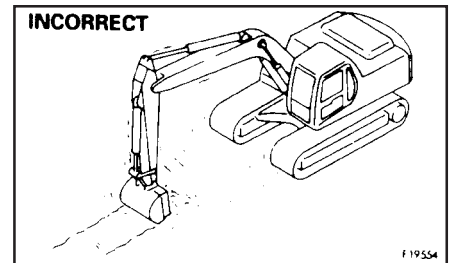

Precautions when operating hydraulic cylinders to end of stroke

If the cylinder is operated to the end of its stroke during operations, force will be brought to bear on the stopper inside the cylinder, and this will reduce the life of the machine. To prevent this, always leave a small safety margin when operating the cylinders.

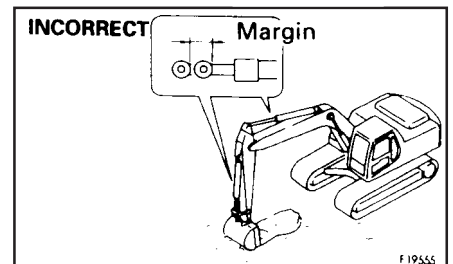

Prohibited operations using dropping force of bucket

Do not use the dropping force of the bucket as a pickaxe, breaker, or pile driver. This will bring excessive force to bear on the rear of the machine, and will not only damage the machine, but is also dangerous.

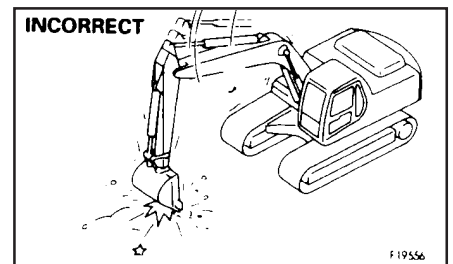

3. Lower the bucket horizontally until the bottom touches the ground.

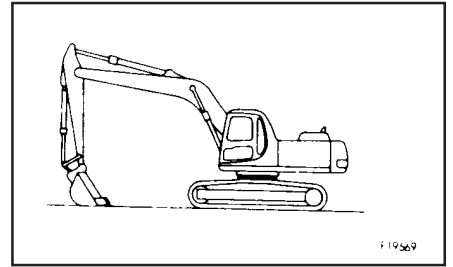

4. Set safety lock lever ③ in the LOCK position.

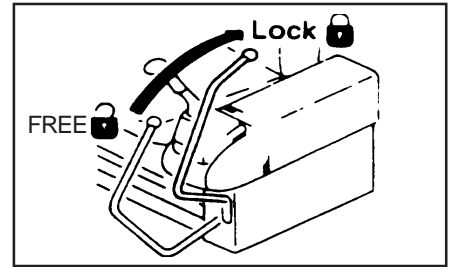

12.17 CHECK AFTER FINISHING WORK

Check the engine water temperature, engine oil pressure and fuel level on the monitor.

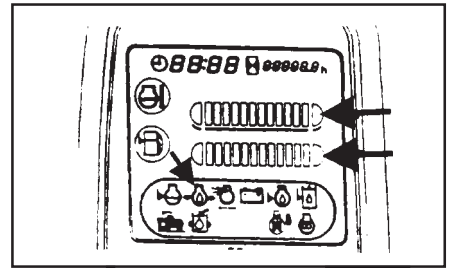

CLICK HERE TO **DOWNLOAD** THE COMPLETE MANUAL

- Thank you very much for reading the preview of the manual.
- You can download the complete manual from: www.heydownloads.com by clicking the link below



- Please note: If there is no response to CLICKING the link, please download this PDF first and then click on it.

CLICK HERE TO **DOWNLOAD** THE COMPLETE MANUAL

15. LONG-TERM STORAGE

15.1 BEFORE STORAGE

NOTICE

To protect the cylinder rod when the machine is not being used, set the work equipment in the posture shown in the diagram.

(This prevents rusting of the cylinder rod)

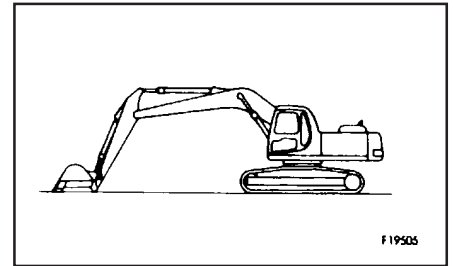

When putting the machine in storage for a long time, do as follows.

- After every part is washed and dried, the machine shall be housed in a dry building. Never leave it outdoors. In case it is indispensable to leave it outdoors, park the machine on the well-drained concrete and cover it with canvas etc.
- Completely fill the fuel tank, lubricate and change the oil before storage.
- Apply a thin coat of grease to metal surface of the hydraulic piston rods.
- Disconnect the negative terminals of the battery and cover it, or remove it from the machine and store it separately.
- If the ambient temperature is expected to drop below 0°C, always add antifreeze to the cooling water.
- Lock each control lever and pedal with the lock lever and pedal lock.
- Set the stop valve to the “lock” position on machines ready for attachments. Install the blind plugs to the elbows.
- Set the selector valve to the “When not use” position on machines ready for attachments.

ENGINE (cont'd) (16.6.3)

Problem	Main causes	Remedy
Exhaust gas is white or blue	<ul style="list-style-type: none"> • Too much oil in oil pan • Improper fuel 	<ul style="list-style-type: none"> • Add oil to specified level see "CHECK BEFORE STARTING" • Change to specified fuel
Exhaust gas occasionally turns black	<ul style="list-style-type: none"> • Clogged air cleaner element • Defective nozzle • Defective compression • Defective turbocharger 	<ul style="list-style-type: none"> • Clean or replace, see "WHEN REQUIRED" (• Replace nozzle) (• See defective compression above) (• Clean or replace turbocharger)
Combustion noise occasionally makes breathing sound	<ul style="list-style-type: none"> • Defective nozzle 	<ul style="list-style-type: none"> (• Replace nozzle)
Abnormal noise generated (combustion or mechanical)	<ul style="list-style-type: none"> • Low grade fuel being used • Overheating • Damage inside muffler • Excessive valve clearance 	<ul style="list-style-type: none"> • Change to specified fuel • Refer to "Radiator water level monitor lights up" as above (• Replace muffler) (• Adjust valve clearance)

18.2 OUTLINE OF ELECTRIC SYSTEM

- If the wiring gets wet or the insulation is damaged, the electric system may earth and could result in hazardous malfunction of the machine.
- Services relating to the electric system are (1) check of fan belt tension, (2) check of damage or wear in the fan belt and (3) check of battery fluid level.
- Never remove or disassemble any electric components installed in the machine.
- Never install any electric components other than these specified by Komatsu.
- Be careful to keep the electric system free of water when washing the machine or when it rains.
- Since the controller for the control system may cause malfunction due to external wave interference, before installing a radio receiver and a walkie-talkie or citizen band, consult your Komatsu distributor.
- When working on the seashore, carefully clean the electric system to prevent corrosion.
- When installing a car cooler or an other electrical equipment, connect it to an independent power source. The optional power source must never be connected to the fuse, starting switch, or battery relay.

SAFETY CRITICAL PARTS

No.	Safety critical parts for periodic replacement	Q'ty	Replacement interval
1	Fuel hose (fuel tank - engine)	1	Every 2 years or 4000 hours, whichever comes sooner
2	Return fuel hose (engine - fuel tank)	1	
3	Front pump hoses (line filter - control valve)	2	Every 2 years or 4000 hours.

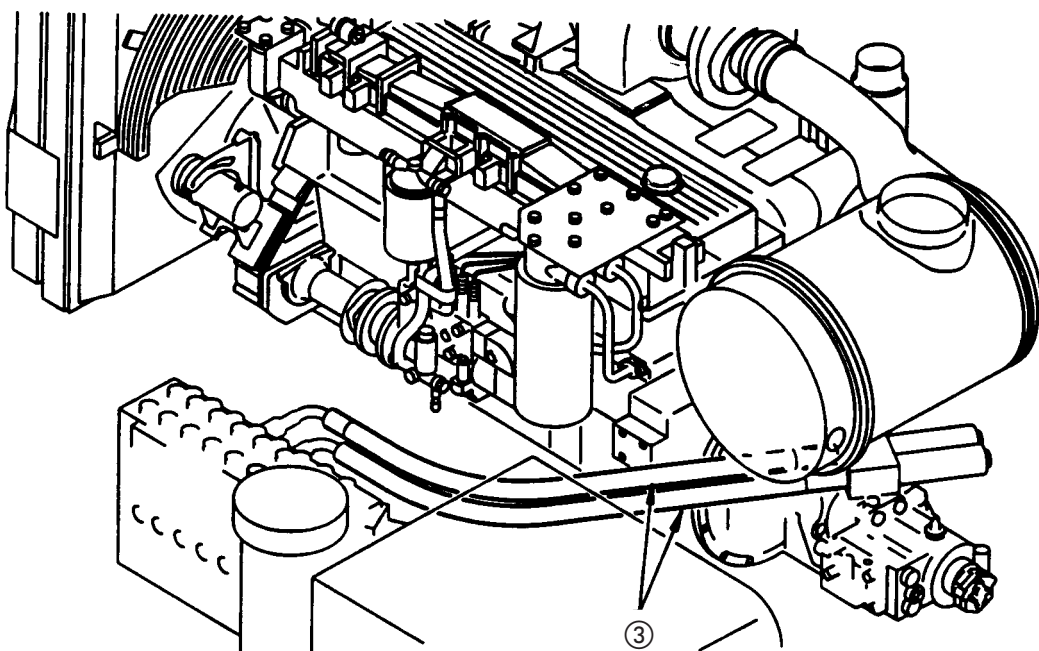
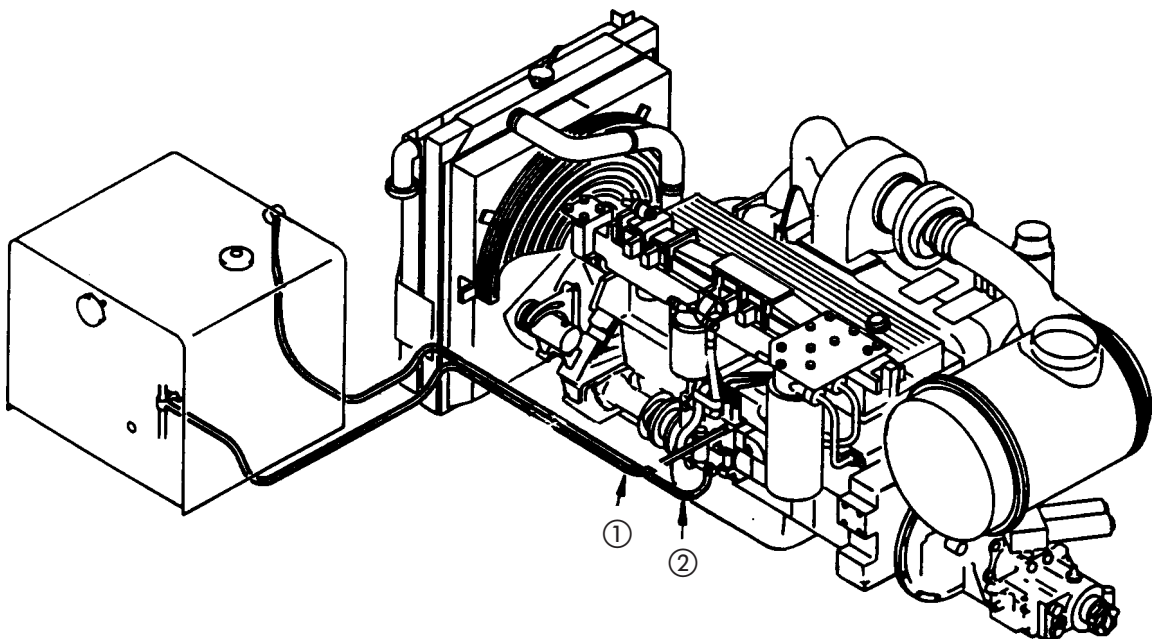

5. Open the cab water heater valves, if equipped.
6. Allow the system to completely drain into a suitable container.
Do not let drain outlets plug up during draining.
7. Close the radiator drain valve.
8. Close the cab heater water valves, if equipped.
9. Do not allow the cooling sytem to dry out.

24.1.21 REMOVAL OF BUCKET TEETH (ESCO VERTALOK® TYPE)

Replace the point before the adapter starts to wear.

⚠ WARNING

It is dangerous if the work equipment moves by mistake when the teeth are being replaced.
Set the work equipment in a stable conditions, then stop the engine and apply the safety lock lever securely.

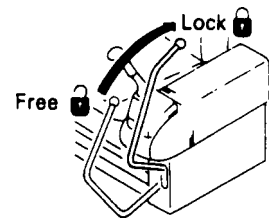

- Place a block under the bottom of the bucket to allow the pin to be knocked out with a hammer. Carry out full stroke operation of the control levers within 15 seconds after stopping the engine. After confirming that the work equipment is in a stable condition, lock the safety lock lever.
Set so that the bottom face of the bucket is horizontal.

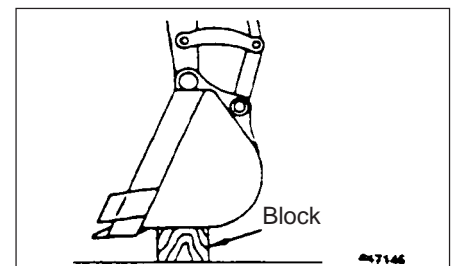

⚠ WARNING

- When installing Vertalok® teeth, always work safely and use proper equipment to avoid injury. Wear OSHA-approved hard hat, safety glasses, gloves, and steeltoed shoes. Be sure other people are out of the way; only one person is needed to install Vertalok® points.
- All struck tools or punches should have a bevel or radius around the striking face that is equal to 1/10th the width of the striking face.
- The rubber plug should be removed prior to any heating or welding near the Vertalok® nose or adapter.

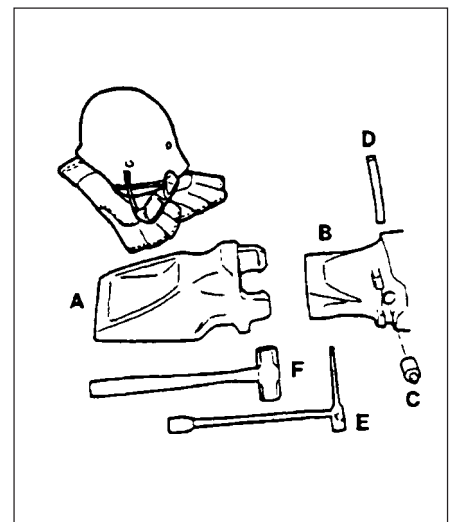

24.3 EVERY 50 HOURS SERVICE

24.3.1 LUBRICATING

NOTICE

For the first 100 hours on new machines where the parts are setting in, carry out greasing every 10 hours.

1. Set the work equipment in the greasing posture below, then lower the work equipment to the ground and stop the engine.
2. Using a grease pump, pump in grease through the grease fittings shown by arrows.

For details of the grease to use, see "20. USE OF FUEL, COOLANT AND LUBRICANTS ACCORDING TO AMBIENT TEMPERATURE" on page 3-12.

3. After greasing, wipe off any old grease that was pushed out.

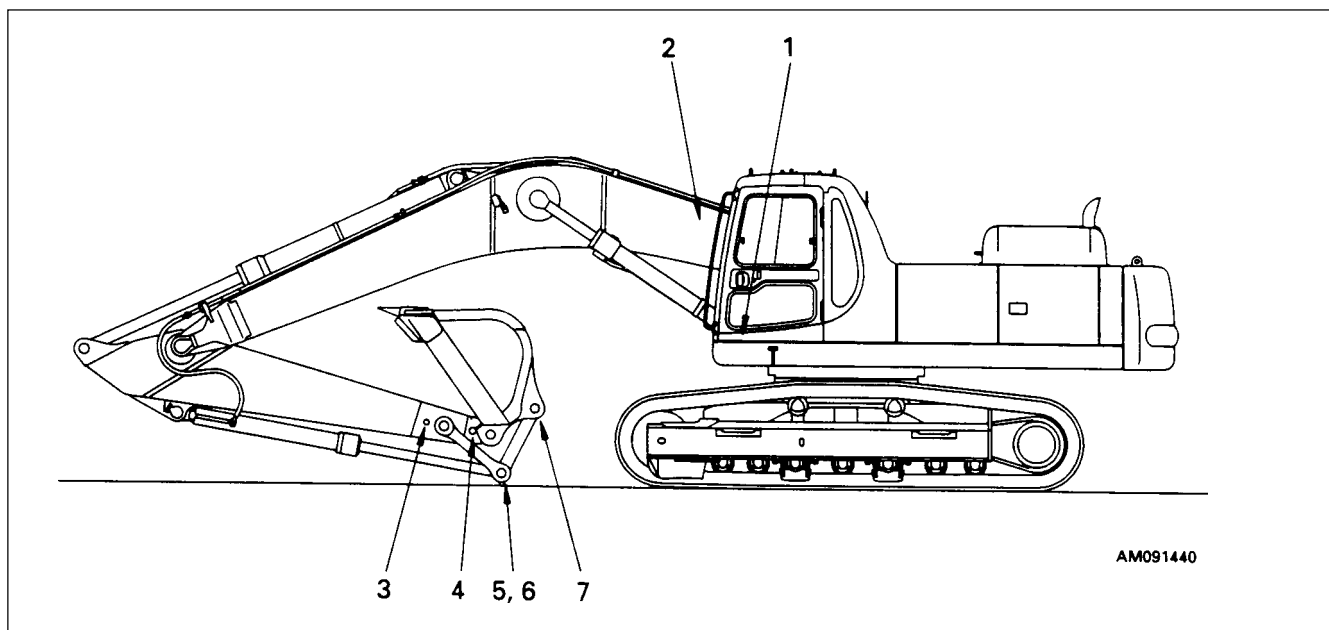

FAN DRIVE BELT - REMOVE

Loosen the idler pulley shaft locknut.

Turn the adjusting screw counterclockwise to release tension, and remove the belt.

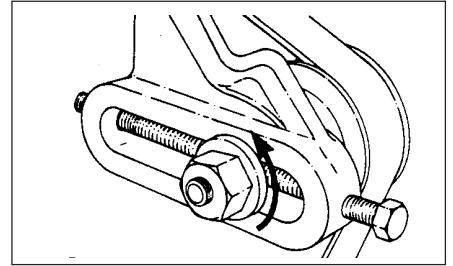
**24.5.7 CHECK ALTERNATOR AND WATER PUMP BELT TENSION, ADJUST CHECKING TENSION**

Use belt tension gauge to measure the belt tension.

Loosen the adjusting screw locknut ①.

Loosen the adjusting link capscrew ②. (2 places)

Loosen the pivot capscrew and nut ③.

Turn the adjusting screw ④ clockwise to increase the belt tension.

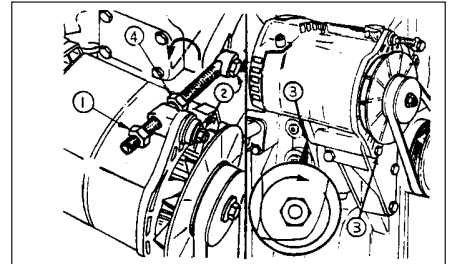

Belt Tension

N		lbf	
670	New	150	
270 to 530	Used	60 to 120	

Tighten the adjusting screw locknut ① against the retainer.

Tighten adjusting link locknuts ②.

Torque Value: 80 N•m [60 ft-lb]

Tighten the pivot capscrew ③ and nut ③.

Torque Value: 47 N•m [35 ft-lb]

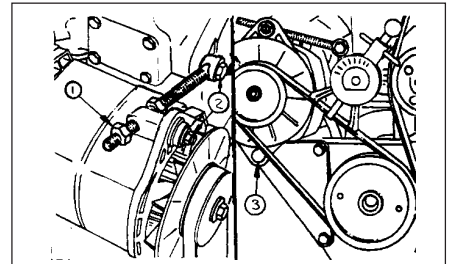
**ALTERNATOR BELT - REMOVAL**

Loosen the adjusting screw locknut ①.

Loosen the adjusting link capscrew ②.

Loosen the pivot capscrew and nut ③.

Turn the adjusting screw ④ to release tension, and remove the belt.

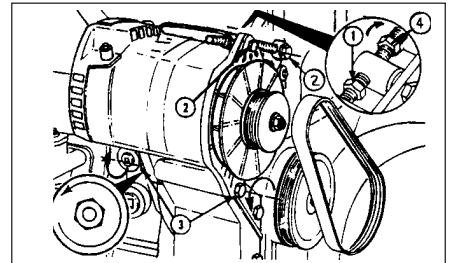

4. Place the STC tappet adjusting tool, Part No.3823348, on the upper surface of the STC injector top-cap. Rotate the tool around the tappet until the tool's locating pin is inserted into one of the four holes in the top of the tappet.

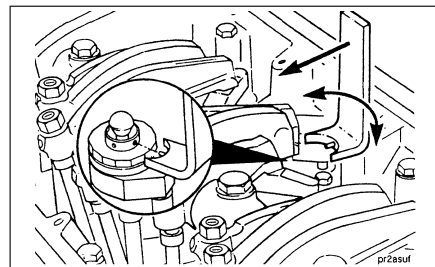

5. Apply thumb pressure to the tool handle to hold the tappet in the maximum upward position.

NOTE: Apply only enough force to the tool to hold the tappet in the maximum upward position. Excess force will cause the tool to break.

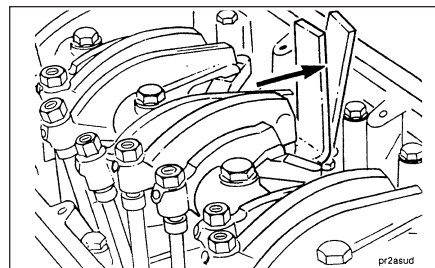

6. An overtightened setting on the injector adjusting screw will produce increased stress on the injector train and the camshaft injector lobe which can result in engine damage.

Use torque wrench, Part No.3376592, to tighten the adjusting screw while holding the tappet in the maximum upward position.

Torque Value: 0.6 to 0.7 N•m [5 to 6 in-lb]

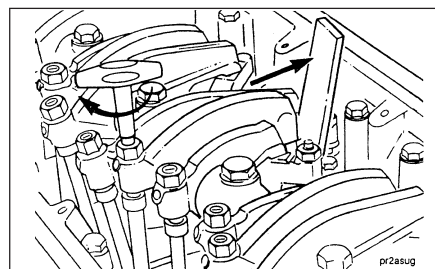

7. Hold the adjusting screw in this position. The adjusting screw must not turn when the locknut is tightened.

Torque Value:

- **Without** Torque Wrench Adapter:
61 N•m [45 ft-lb]
- **With** Torque Wrench Adapter (1):
47 N•m [35 if-lb]

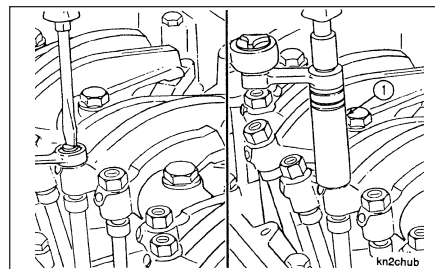

8. The tappet tool must be removed before rotating the crankshaft to prevent damage to the tappet.

Remove the tappet adjusting tool.

Check to make sure the injector push rod can be rotated by hand. If it can't, the setting is too tight.

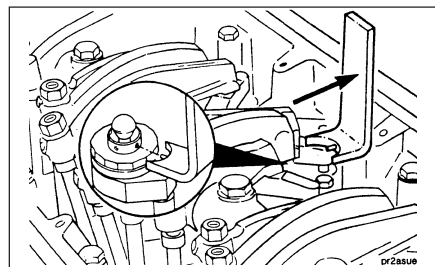

24.8.3 CHECK ALTERNATOR, STARTING MOTOR

The brush may be worn, or the bearing may have run out of grease, so contact your Komatsu distributor for inspection or repair. If the engine is started frequently, carry out inspection every 1000 hours.

24.8.4 CHECK WATER PUMP

Check that there is no oil leakage, water leakage, or clogging of the drain hole. If any abnormality is found, contact your Komatsu distributor for disassembly and repair or replacement.

24.8.5 CHECK ALL TIGHTENING PARTS OF TURBO CHARGER

Contact your Komatsu distributor to have the tightening portions checked.

Crankcase Breather Tube Cleaning and Checking

The tube must be removed and checked internally for obstructions or sludge buildup. If the tube is blocked, the tube and crankcase breather must be cleaned to prevent excess crankcase pressure buildup.

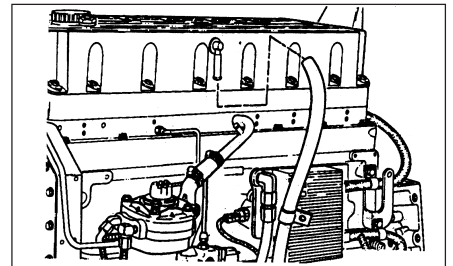

PC450, PC450LC-6k

[]: Values are for PC450LC-6k.

- : Values are for trackframe in transport position.

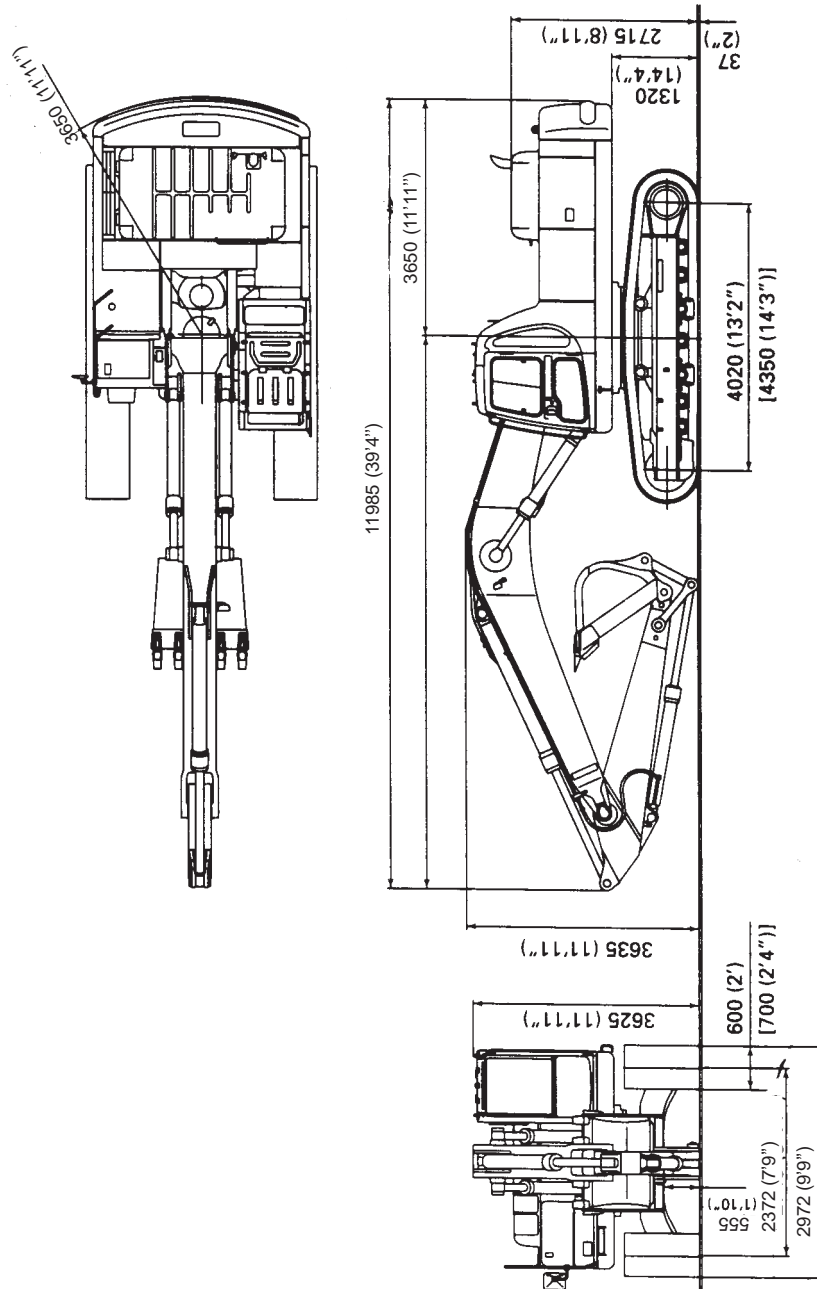

AM096370



28.2 HYDRAULIC CIRCUIT

Change-over hydraulic circuit

When the machine is equipped with an attachment or a bucket, set left and right 3-way valve ① as follows.

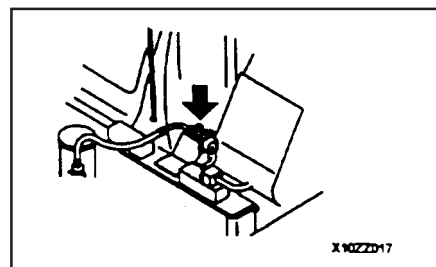
Referring to the following chart, turn the rotor of the right 3-way valve ① using a wrench to select the attachment to be mounted. (The arrows indicating the port direction are stamped on the 3-way valve head).



Attachment	Right 3-way valve ①
Breaker etc.	Right of machine 
Crusher etc.	Right of machine 
When not used	Right of machine 

NOTICE

- When the machine is equipped with the breaker, connect the return circuit directly to the return filter.
- The set pressure of the relief valve is set to 20600 kPa (210 kg/cm², 2980 psi) as standard when delivered from the factory. If a breaker by another manufacturer is installed, adjustment is required. Consult your Komatsu distributor.

29.5 HANDLING TRAPEZOIDAL BUCKET

This bucket is used to dig trapezoidal ditches on paddy fields, farmland ect. and can dig 3 types of ditch gradients (45°, 40° and 38°) when a movable plate is attached.

- The mounting position of the movable plate varies depending on whether the ditch gradient is 45°, 40° or 38°.

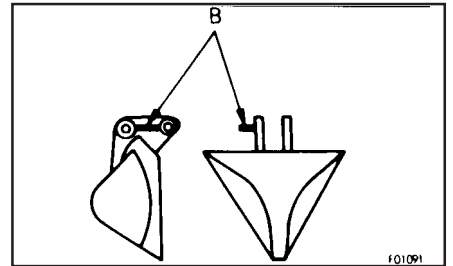
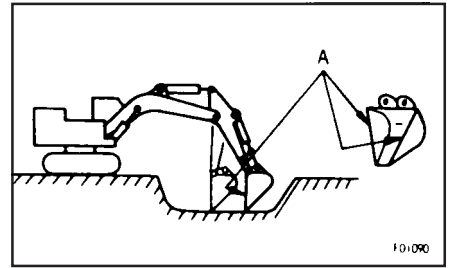

How to perform excavation

Operate the boom, the arm and the bucket to make the line ① of the side-plate of the bucket vertical.

The guide plate ② to check this position is installed beside the bucket pins. Accordingly, hold this plate horizontal when digging.

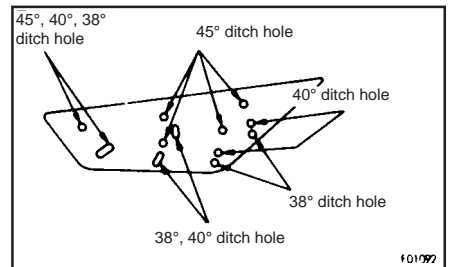

Ditch gradient of 45°

Attached the bucket only or the movable plate by selecting the related ditch holes. Perform digging by the above method.

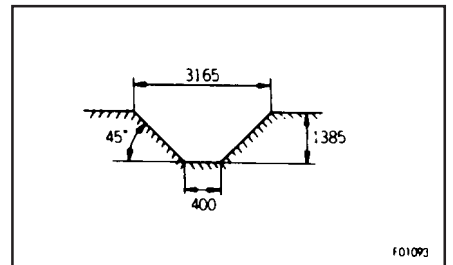

Ditch gradient of 40° or 38°

Attached the bucket only or the movable plate by selecting the related ditch holes. Perform digging by the above method. Even if the trapezoidal bucket is provided with the movable plate, always perform digging with the bucket side face perpendicular to the ground.

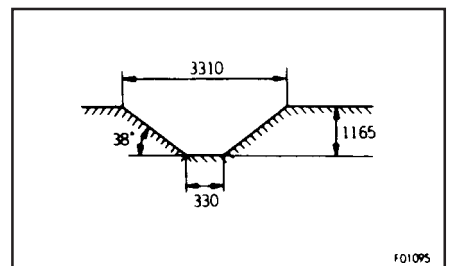
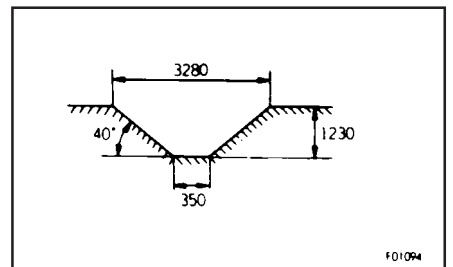

CLICK HERE TO **DOWNLOAD** THE COMPLETE MANUAL

- Thank you very much for reading the preview of the manual.
- You can download the complete manual from: www.heydownloads.com by clicking the link below



- Please note: If there is no response to CLICKING the link, please download this PDF first and then click on it.

CLICK HERE TO **DOWNLOAD** THE COMPLETE MANUAL