

# Operation & Maintenance Manual

TEN00056-02

## **GALEO**

# **PC300,300LC-7**

# **PC350,350LC-7**

### **HYDRAULIC EXCAVATOR**

SERIAL NUMBERS PC300,300LC-45001 and up  
PC350,350LC-25001

#### **⚠ WARNING**

Unsafe use of this machine may cause serious injury or death. Operators and maintenance personnel must read this manual before operating or maintaining this machine. This manual should be kept near the machine for reference and periodically reviewed by all personnel who will come into contact with it.

#### **NOTICE**

Komatsu has Operation & Maintenance Manuals written in some other languages. If a foreign language manual is necessary, contact your local distributor for availability.

# **KOMATSU**

CLICK HERE TO **DOWNLOAD** THE COMPLETE MANUAL

- Thank you very much for reading the preview of the manual.
- You can download the complete manual from: [www.heydownloads.com](http://www.heydownloads.com) by clicking the link below



- Please note: If there is no response to CLICKING the link, please download this PDF first and then click on it.

CLICK HERE TO **DOWNLOAD** THE COMPLETE MANUAL

# CONTENTS

## FOREWORD

<b>FOREWORD</b> .....	1-2
<b>SAFETY INFORMATION</b> .....	1-5
<b>INTRODUCTION</b> .....	1-7
DIRECTIONS OF MACHINE .....	1-7
BREAKING-IN OPERATION .....	1-7
<b>PRODUCT INFORMATION</b> .....	1-8
PRODUCT IDENTIFICATION NUMBER (PIN), MACHINE SERIAL NO. PLATE .....	1-8
ENGINE SERIAL NUMBER PLATE AND ITS LOCATION .....	1-8
SERVICE METER LOCATION .....	1-9
YOUR MACHINE SERIAL NUMBERS AND DISTRIBUTOR .....	1-9

## SAFETY

<b>SAFETY INFORMATION</b> .....	2-2
<b>POSITION FOR ATTACHING SAFETY LABELS</b> .....	2-4
POSITION FOR ATTACHING SAFETY LABELS .....	2-4
SAFETY LABELS .....	2-5
<b>SAFETY INFORMATION</b> .....	2-10
<b>SAFETY MACHINE OPERATION</b> .....	2-19
STARTING ENGINE .....	2-19
OPERATION .....	2-21
TRANSPORTATION .....	2-27
BATTERY .....	2-28
TOWING .....	2-30
LIFTING OBJECTS WITH BUCKET .....	2-31
<b>SAFETY MAINTENANCE INFORMATION</b> .....	2-32

## OPERATION

<b>GENERAL VIEW</b> .....	3-2
GENERAL VIEW OF MACHINE .....	3-2
GENERAL VIEW CONTROLS AND GAUGES .....	3-3
<b>EXPLANATION OF COMPONENTS</b> .....	3-4
MACHINE MONITOR .....	3-4
BASIC CHECK ITEMS .....	3-5

(4) Warnings for high voltage (09801-03001)

**⚠ DANGER**

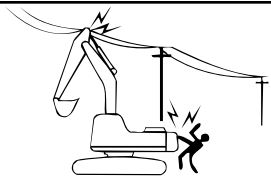

Hazardous voltage hazard. Serious injury or death can occur if machine or attachments are not kept safe distance away from electric lines.

VOLTAGE		SAFE DISTANCE
LOW VOLTAGE	100V-200V	2m
	6.600V	2m
	22.000V	3m
	66.000V	4m
SPECIAL HIGH VOLTAGE	154.000V	5m
	187.000V	6m
	275.000V	7m
	500.000V	11m

09801-03001

(5) Warnings when opening front window (09839-03000)

**⚠ WARNING**

To open or close the front or ceiling window, never stand up from the operator's seat before throwing the safety lock lever to the LOCK position.

Inadvertently touching any of the working equipment control levers might cause the machine to start moving all of a sudden, probably resulting in a serious injury.

09839-03000

(6) Warnings when stowing front window (09803-03000)

**⚠ WARNING**

When raising window, lock it in place with lock pins on both sides.

Falling window can cause injury.

09803-03000

(7) Precautions for high-temperature oil (09653-03001)

**⚠ WARNING**

Hot oil hazard.

To prevent hot oil from spurt-ing out:

- Turn engine off.
- Allow oil to cool.
- Slowly loosen cap to relieve pressure before removing.

09653-03001

## ATTACHMENT COMBINATIONS

Depending on the type or combination of work equipment, there is a hazard that the work equipment may hit the cab or other parts of the machine. Before using unfamiliar work equipment, check if there is any hazard of interference, and operate with caution.

## CAB WINDOW GLASSES

- If the cab glass on the work equipment side is broken, there is a hazard that the work equipment may contact the operator's body directly. Stop operation immediately and replace the glass.
- Use water to clean roof windows made of organic glass (polycarbonate); do not use any organic solvent. If benzene, toluene, methanol, or other organic solvents are used, there will be chemical reactions such as the glass dissolving or decomposing, and the polycarbonate will deteriorate.

## UNAUTHORIZED MODIFICATIONS

Any modification made without authorization from Komatsu can create hazards. Before making a modification, consult your Komatsu distributor.

- Komatsu will not be responsible for any injuries, accidents, or product failures resulting from modifications made without authorization from Komatsu.

## SAFETY AT JOBSITE

Before starting operations, thoroughly check the area for any unusual conditions that could be dangerous.

- When carrying out operations near combustible materials such as thatched roofs, dry leaves or dry grass, there is a hazard of fire, so be careful when operating.
- Check the terrain and condition of the ground at the worksite, and determine the safest method of operation. Do not carry out operations at places where there is a hazard of landslides or falling rocks.
- If water lines, gas lines, or high-voltage electrical lines may be buried under the worksite, contact each utility and identify their locations. Be careful not to sever or damage any of these lines.

- Take action to prevent unauthorized people from approaching the jobsite.

When working on public roads, position flagmen and erect barriers to ensure the safety of passing traffic and pedestrians.

- When traveling or operating in shallow water or on soft ground, check the shape and condition of the bedrock, and the depth and speed of flow of the water before starting operations.

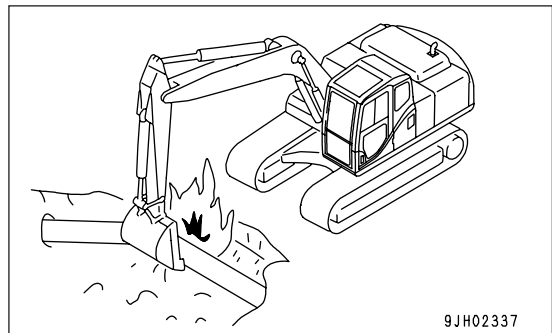

## OPERATIONS ON SNOW

- Snow-covered or frozen surfaces are slippery, so be extremely careful when traveling or operating the machine, and do not operate the levers suddenly. Even a slight slope may cause the machine to slip, so be particularly careful when working on slopes.
- With frozen ground surfaces, the ground becomes soft when the temperature rises, and this may cause the machine to tip over.
- If the machine enters deep snow, there is a hazard that it may tip over or become buried in the snow. Be careful not to leave the road shoulder or to get trapped in a snow drift.
- When clearing snow, the road shoulder and objects placed beside the road are buried in the snow and cannot be seen. There is a hazard of the machine tipping over or hitting covered objects, so always carry out operations carefully.

## PARKING MACHINE

- Park the machine on firm, level ground.
- Select a place where there is no hazard of falling rocks or landslides, or of flooding if the land is low.
- Lower the work equipment completely to the ground.

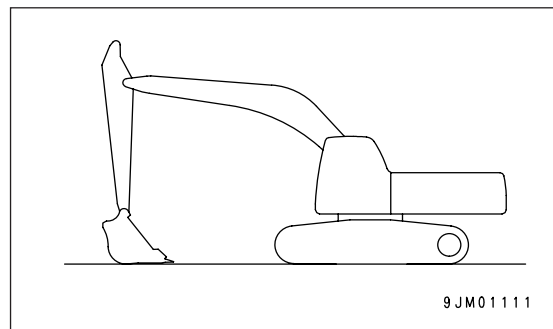

- When leaving the machine, set lock lever (1) to the LOCK position, then stop the engine.
- Always close the operator's cab door, and use the key to lock all the equipment in order to prevent any unauthorized person from moving the machine. Always remove the key, take it with you, and leave it in the specified place.

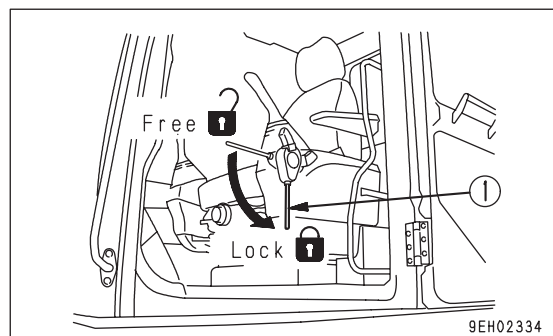

- If it is necessary to park the machine on a slope, always do as follows.
  - Set the bucket on the downhill side, then dig it into the ground.
  - Put blocks under the tracks to prevent the machine from moving.

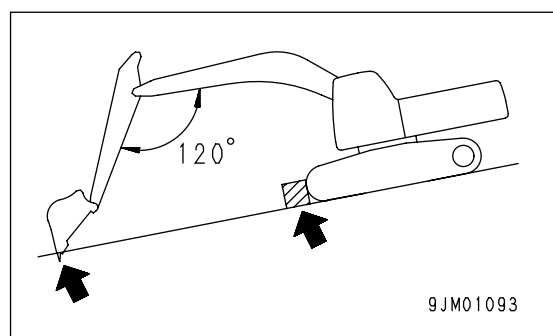

## NOISE

If the noise from the machine is too loud, it may cause temporary or permanent hearing problems.

When carrying out maintenance of the engine and you are exposed to noise for long periods of time, wear ear covers or ear plugs while working.

## WHEN USING HAMMER

When using a hammer, pins may fly out or metal particles may be scattered. This may lead to serious injury. Always do as follows.

- If hard metal parts such as pins, bucket teeth, cutting edges, or bearings are hit with a hammer, there is a hazard that pieces might be scattered and cause injury. Always wear safety goggles and gloves.
- When hitting pins or bucket teeth, there is a hazard that broken pieces might be sent flying and injure people in the surrounding area. Always check that there is no one in the surrounding area.
- If pins are hit with strong force, there is a hazard that the pin may fly out and injure people in the surrounding area.

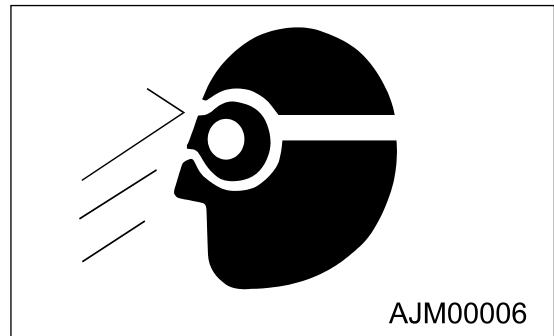

## WELDING WORKS

Welding operations must always be carried out by a qualified welder and in a place equipped with a proper equipment. There is a hazard of fire or electrocution when carrying out welding, so never allow any unqualified personnel to carry out welding.

## REMOVING BATTERY TERMINALS

When repairing the electrical system or when carrying out electrical welding, remove the negative (-) terminal of the battery to prevent the flow of current.

## CAUTION ITEMS

 CAUTION

If the warning monitor flashes or lights up, carry out inspection and maintenance of the appropriate point as soon as possible.

If the problem is not corrected, it may lead to failure of the machine.

These are items which need to be observed when the engine is running. If any abnormality occurs, the item needing immediate repair is displayed. If there is any abnormality, the abnormal location on the monitor will flash or light up.

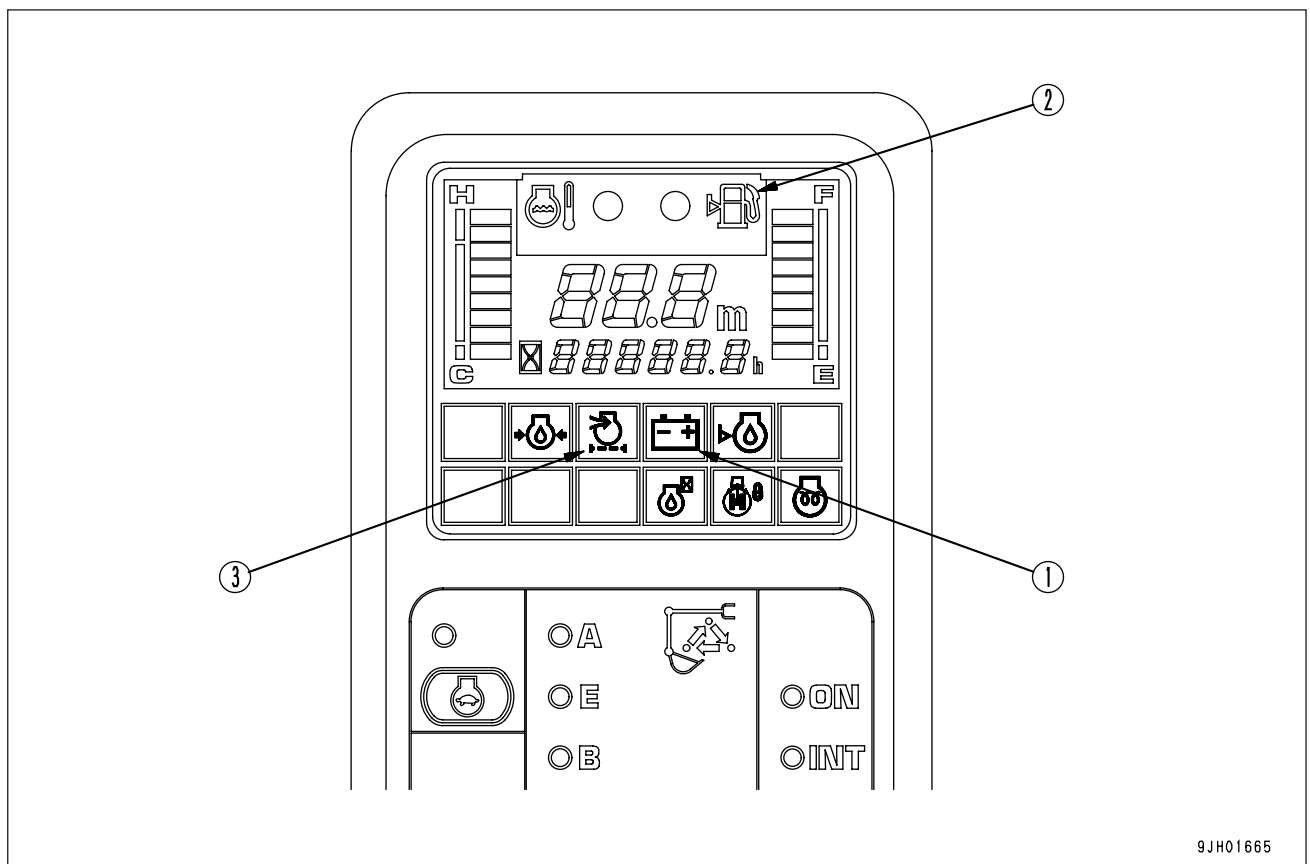

9JH01665

- (1) Charge level monitor
- (2) Fuel level monitor

- (3) Air cleaner clogging monitor

# SWITCHES

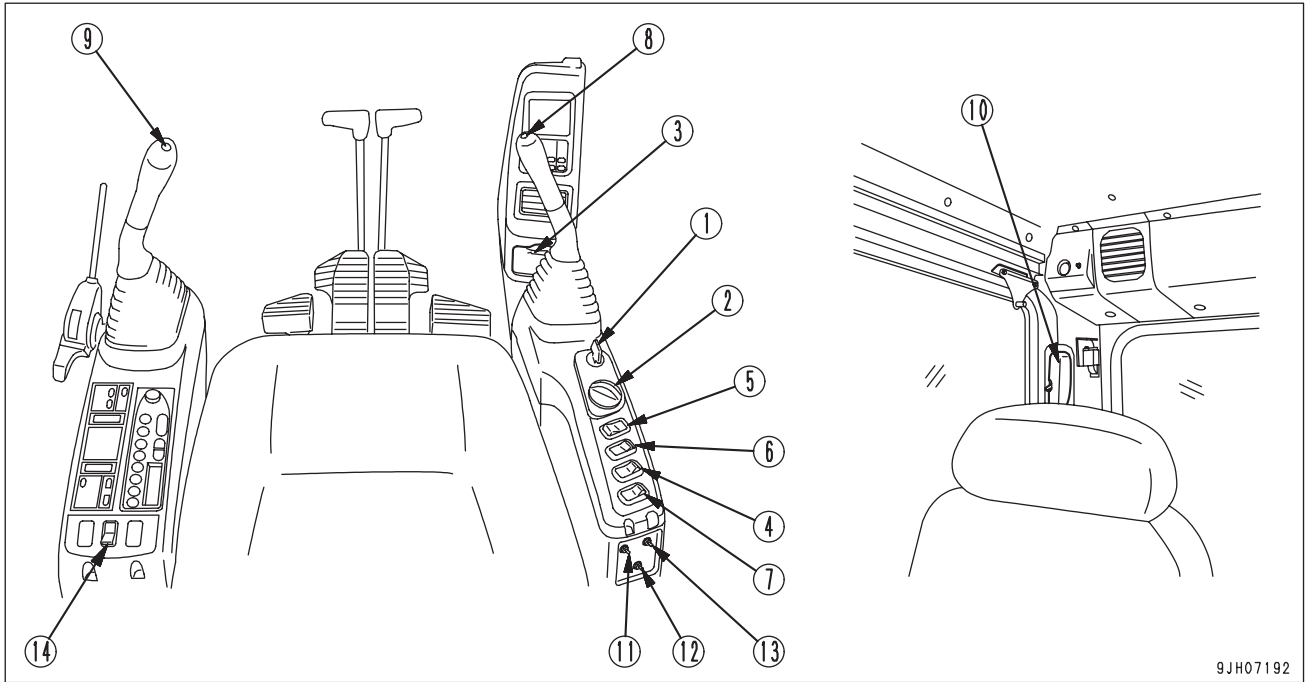

- |                              |   |
|------------------------------|---|
| (1) Starting switch          | (8) Horn switch                           |
| (2) Fuel control dial        | (9) Knob switch                           |
| (3) Cigarette lighter        | (10) Room lamp switch                     |
| (4) Swing lock switch        | (11) Emergency pump drive switch          |
| (5) Lamp switch              | (12) Emergency fuel solenoid drive switch |
| (6) Alarm buzzer stop switch | (13) Swing brake cancel switch            |
| (7) Machine push-up switch   | (14) Rotating lamp switch (if equipped)   |

## STARTING SWITCH

This switch (1) is used to start or stop the engine.

### OFF position

The key can be inserted or withdrawn. The switches for the electric system except the room lamp, are all turned off and the engine is stopped.

### ON position

Electric current flows in the charging and lamp circuits. Keep the starting switch key at the ON position while the engine is running.

### START position

This is the engine-start position. Keep the key at this position during cranking. Immediately after starting the engine, release the key. It will automatically return to the ON position.

### HEAT (preheat) position

When starting the engine in winter, set the key to this position. When the key is set to the HEAT position, the pre-heating monitor lights up. Keep the key at this position until the monitor lamp flashes. Immediately after the pre-heating monitor flashes, release the key. The key automatically returns to the OFF position. Then, start the engine by turning the key to the START position.

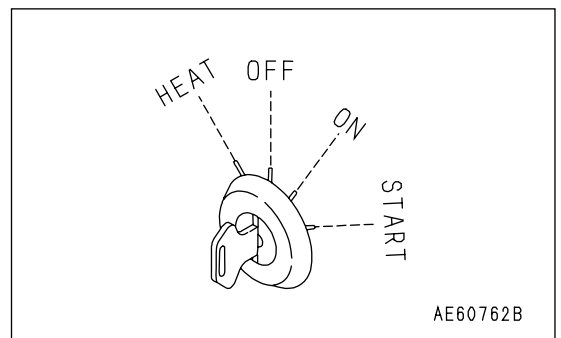

AE60762B

## FRONT WINDOW

### WARNING

- Before opening or closing the front window, bottom window, or door, always set lock lever (1) to the LOCK position. If the control levers are touched by mistake, it may lead to serious personal injury or death.
- Before opening or closing the front window of the cab, lower the work equipment to the ground at a horizontal place, then stop the engine.
- When opening the front window, hold the grips securely with both hands, pull up, and do not release until the window fits on the automatic lock catch.
- When closing the front window, there is danger of the window coming down under its own weight, so hold the grips securely with both hands and close the window.

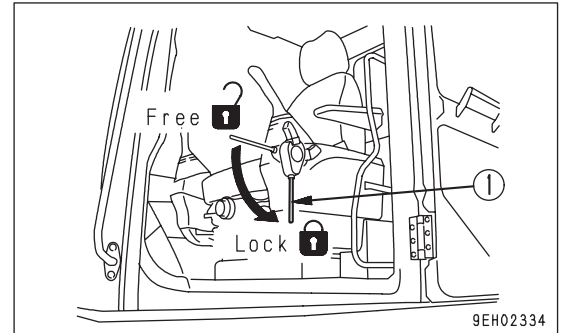

It is possible to store (pull up) the front window (top) in the roof of the operator's compartment.

### When opening

1. Move the machine to a horizontal place, lower the work equipment completely to the ground, then stop the engine.
2. Set the lock lever securely to the LOCK position.
3. Check that the wiper blade is stored in the right stay.

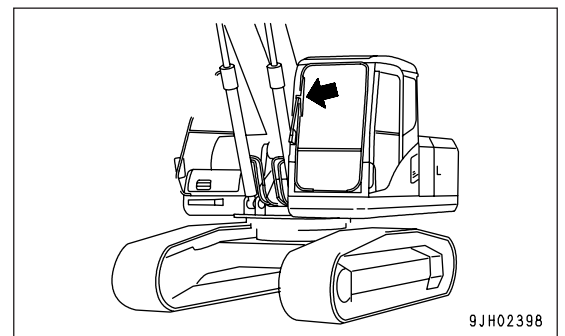

**VENT SELECTOR SWITCH**

This switch (4) is used to select the vents.

- When switch (4) is pressed, the display on monitor display (7) switches and air blows out from the vents displayed.
- During automatic operation, the vents are automatically selected.

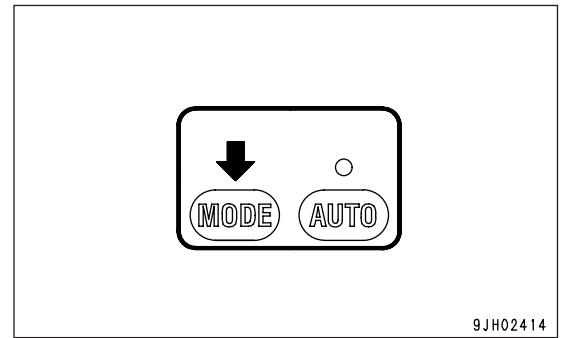

- (A): Rear vents (4 places)
- (B1): Face vent (1 place)
- (B2): Front window vent (1 place)
- (C): Foot vent (1 place)
- (D): Front window vent (1 place)

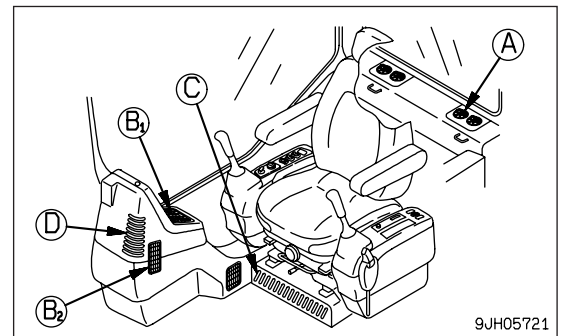

Liquid crystal display	Vent mode	Vent				Remarks
		(A)	(B)	(C)	(D)	
	Front vents		○			Cannot be selected for automatic operation
	Front and rear vents	○	○			-
	Front, rear and foot vents	○	○	○		-
	Foot vent			○		-
	Foot vent Defroster vent			○	○	Cannot be selected for automatic operation
	Defroster vent				○	Cannot be selected for automatic operation

Note 1: Air blows out from vents marked ○

## OTHER FUNCTIONS

### SELF-DIAGNOSTIC FUNCTION

It is possible to carry out troubleshooting of the various sensors and equipment used on the air conditioner.

1. Turn the starting switch key to the ON (B) position.
2. Press OFF switch (1). The temperature setting and air flow display on the liquid crystal display portion go out and operation stops.
3. If the "∨" and "∧" parts of temperature setting switch (3) are kept pressed at the same time for at least 3 seconds, the troubleshooting mode is displayed on the liquid crystal display portion.

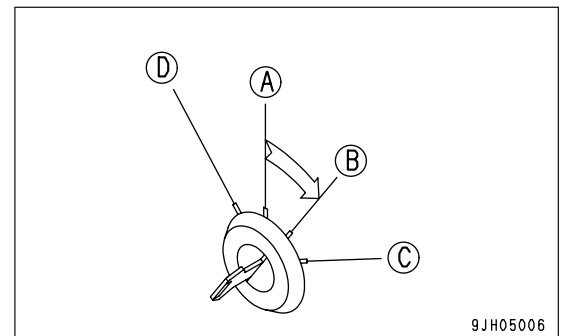

9JH05006

<Monitor display and failure mode>

Display	Failure mode
E--	No failure
E11	Disconnection in recirculated air sensor
E12	Short circuit in recirculated air sensor
E15	Disconnection in water temperature sensor
E16	Short circuit in water temperature sensor
E18	Short circuit in sunlight sensor
E43	Abnormality in vent damper
E44	Abnormality in air mix damper
E45	Abnormality in FRESH/RECIRC air damper

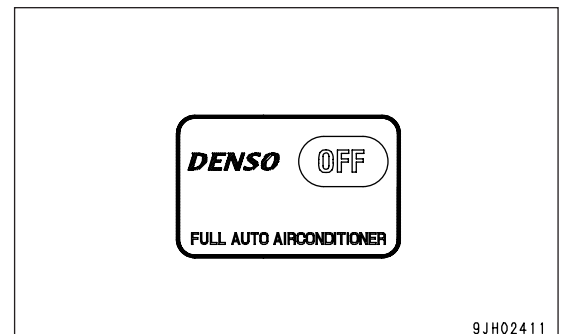

9JH02411

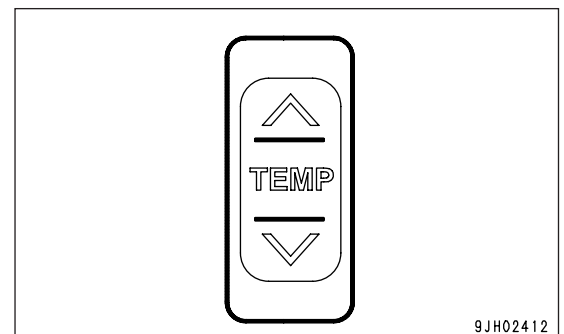

9JH02412

- When more than one failure is detected, press the "∨" or "∧" portion of temperature setting switch (3) to display the failures in turn.
- After completing the troubleshooting, press OFF switch (1) again to return to the normal display.

If any abnormality is detected by the self-diagnostic function, ask your Komatsu distributor to carry out inspection and repair.

## CONTROLLER (COMPUTER)

An engine throttle and pump controller is installed.

### NOTICE

- Be careful not to get water, mud, or juice on the controller. This will cause failure.
- If any abnormality occurs in the controller, do not disassemble it yourself. Contact your Komatsu distributor for repairs.

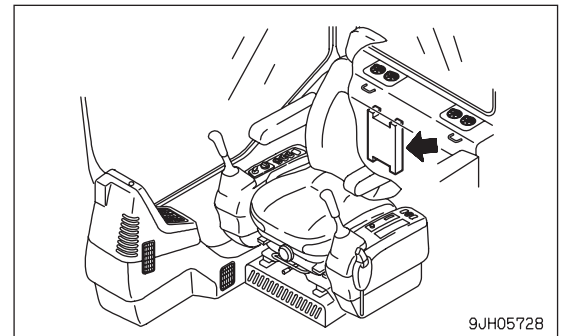

## TOOLBOX

Keep the tools in this toolbox.

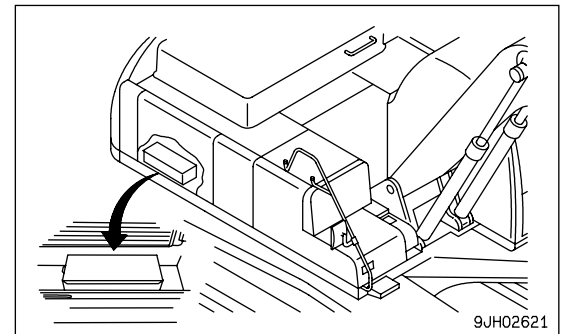

### NOTICE

Do not put large tools into the toolbox if they prevent the cover from closing. There is danger that the radiator fins may be damaged. Put large tools in the utility space. The utility space is inside the front door on the left side of the machine.

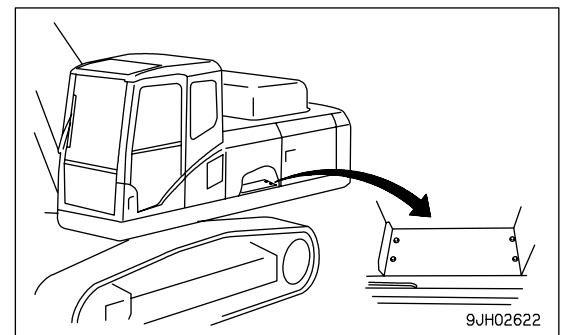

## GREASE GUN HOLDER

This is inside the front door on the right side of the machine. When not using the grease gun, fit it in this holder.

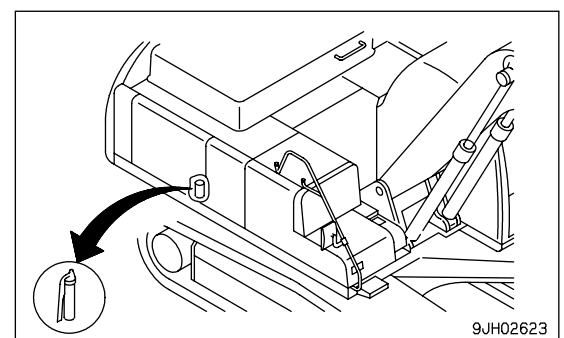

## ADJUST BEFORE OPERATION

### WARNING

When adjusting the position of the operator's seat, always set lock lever (1) to the LOCK position to prevent any movement of the machine if the control levers are touched by mistake.

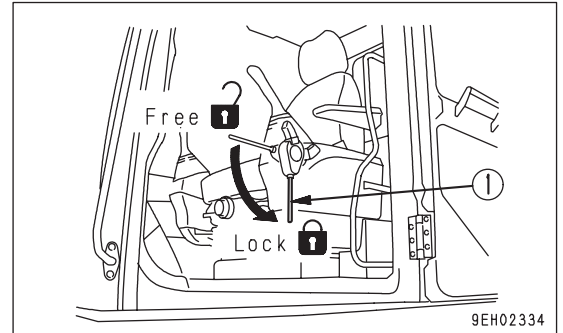

#### A: Fore-and-aft adjustment

Pull lever (1) up, set the seat to the desired position, then release the lever.

Fore-and-aft adjustment: 160 mm (6.3 in) (16 stages)

#### B: Adjusting reclining

##### NOTICE

The seat can be reclined to a large angle when the seat is pushed fully forward, but the reclining angle is reduced when the seat is moved back, so when moving the seat to the rear, return the seat back to its original position.

Pull lever (2) and set the seat back to a position which is comfortable for operation, then release the lever.

Sit with your back against the seat back when adjusting. If your back is not touching the seat back, the seat back may suddenly move forward.

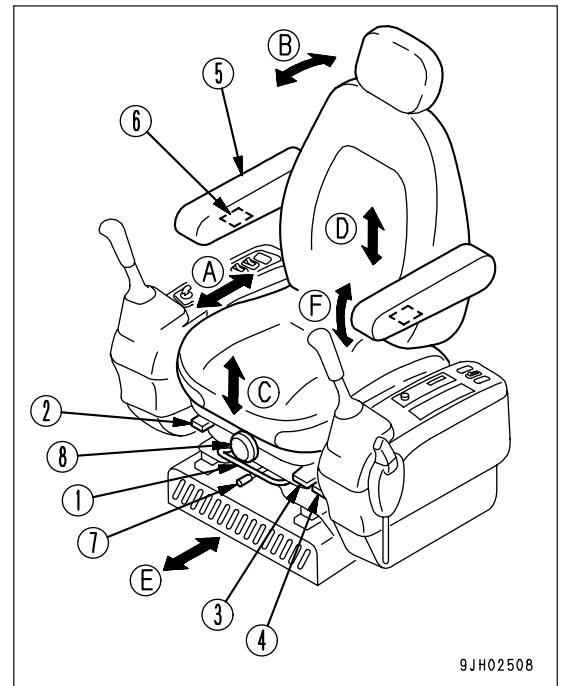

#### C: Adjusting seat tilt

##### ● Forward tilt

Push lever (3) up to adjust the angle of the front of the seat. (4 stages)

- To raise the angle at the front of the seat, keep the lever pushed up and apply your weight to the rear of the seat.
- To lower the angle at the front of the seat, keep the lever pushed up and apply your weight to the front of the seat.

##### ● Rear tilt

Pull lever (4) up to adjust the angle of the rear of the seat. (4stages)

- To raise the angle at the rear of the seat,keep the lever (3) pulled up and stand up slightly to remove your weight from the seat.
- To lower the angle at the rear of the seat,keep the lever (3) pulled up and apply your weight to the rear of the seat.

Amount of tilt: Up 13°, down 13°

##### ● Adjusting seat height

It is possible to move the seat up or down by combining adjustments 1 and 2.

After setting the forward tilt or rear tilt to the desired height, operate the opposite part to set the seat horizontal then secure in position.

Height adjustment: 60 mm (2.4 in)

## AFTER STARTING ENGINE

### ⚠ WARNING

- **Emergency stop**  
If there has been any abnormal actuation or trouble, turn the starting switch key to the OFF position.
- If the work equipment is operated without warming the machine up sufficiently, the response of the work equipment to the movement of the control lever will be slow, and the work equipment may not move as the operator desires, so always carry out the warming-up operation. Particularly in cold areas, be sure to carry out the warming-up operation fully.

## WARMING-UP OPERATION

### NOTICE

- When the hydraulic oil is at a low temperature, do not carry out operations or move the levers suddenly. Always carry out the warming-up operation. This will help to extend the machine life.
- Do not suddenly accelerate the engine before the warming-up operation is completed. Do not run the engine at low idling or high idling continuously for more than 20 minutes. This will cause leakage of oil from the turbocharger oil supply piping. If it is necessary to run the engine at idling, apply a load from time to time or run the engine at a mid-range speed.

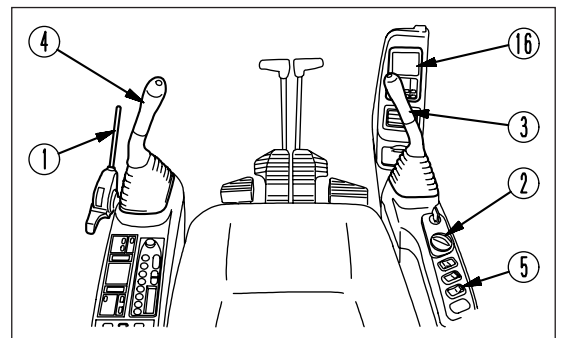

### REMARK

- If the engine water temperature is above 30°C, to protect the turbocharger, the engine speed does not rise for 2 seconds after starting, even if the fuel control dial is turned.
- If the hydraulic oil temperature is low, the hydraulic oil temperature monitor display will be white.

After starting the engine, do not immediately start operations. First, carry out the following operations and checks.

1. Turn fuel control dial (2) to the center position between LOW IDLING and HIGH IDLING and run the engine at medium speed for about 5 minutes with no load.

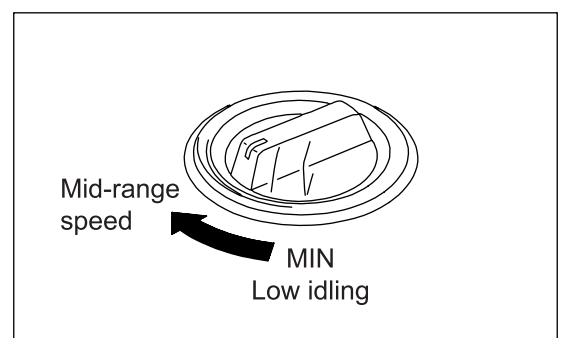

2. Move lock lever (1) slowly, set it securely to the FREE position, then raise the bucket from the ground surface.

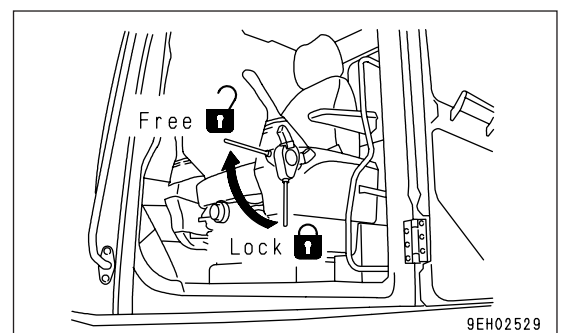

9EH02529

## STEERING THE MACHINE

### Steering

#### WARNING

Before operating the travel levers, check the position of the sprocket. If the sprocket is at the front, the operation of the travel levers is reversed.

Use the travel levers to change direction.

Avoid sudden changes of direction as far as possible. In particular, when carrying out counter-rotation (spin turn), stop the machine first before turning.

Operate two travel levers (1) as follows.

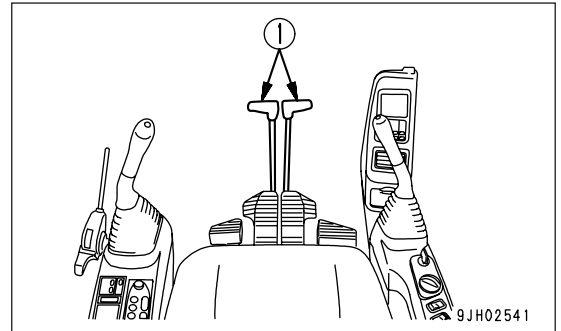

### Steering the Machine when Stopped

When turning to the left:

Push the right travel lever forward to turn to the left when traveling forward; and pull it back to turn left when traveling in reverse.

#### REMARK

When turning to the right, operate the left travel lever in the same way.

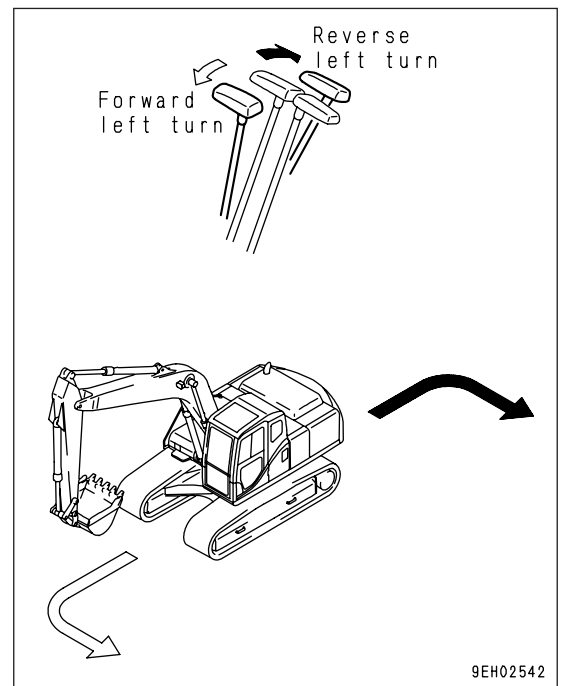

2. When traveling up a steep hill of more than 15°, set the work equipment to the posture shown in the diagram on the right.

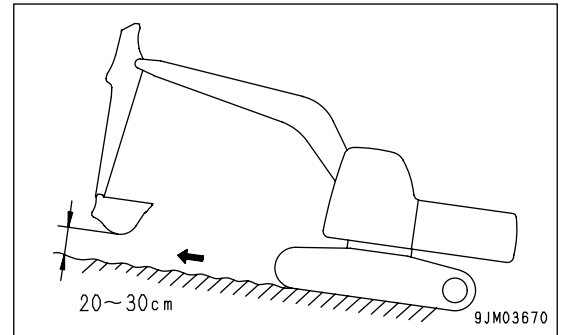

- When traveling up steep slopes, to ensure the balance, extend the work equipment to the front, keep it raised 20 - 30cm (10 - 20in) from the ground surface, and travel at low speed.

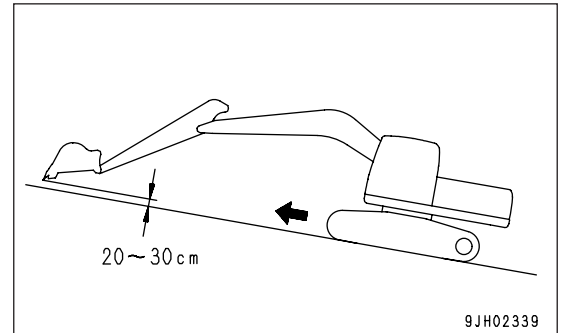

## TRAVELING DOWNHILL

To brake the machine during downhill runs, put the travel lever in the neutral position. This will cause the brake to be automatically applied.

## ENGINE STOPPED ON SLOPE

If the engine stops when traveling uphill, move the all levers to the neutral position, then start the engine again.

## PRECAUTIONS ON SLOPES

- If the engine stops when the machine is on a slope, never use the left work equipment control lever to carry out swing operations. The upper structure will swing under its own weight.
- Be extremely careful when opening or closing the door on slopes. The weight of the door may cause the door to open or close suddenly.  
Always set the door so that it is firmly locked in position.

## LOCKING

Always lock the following places.

- (1) Door of operator's cab  
Always remember to close the window.
- (2) Fuel tank filler port
- (3) Engine hood
- (4) Battery box cover
- (5) Left side door of the machine
- (6) Right side door of the machine
- (7) Battery box side cover  
(only machines equipped with fuel supply pump)
- (8) Hydraulic tank filler port

### REMARK

Use the starting switch key to open and close all these places.

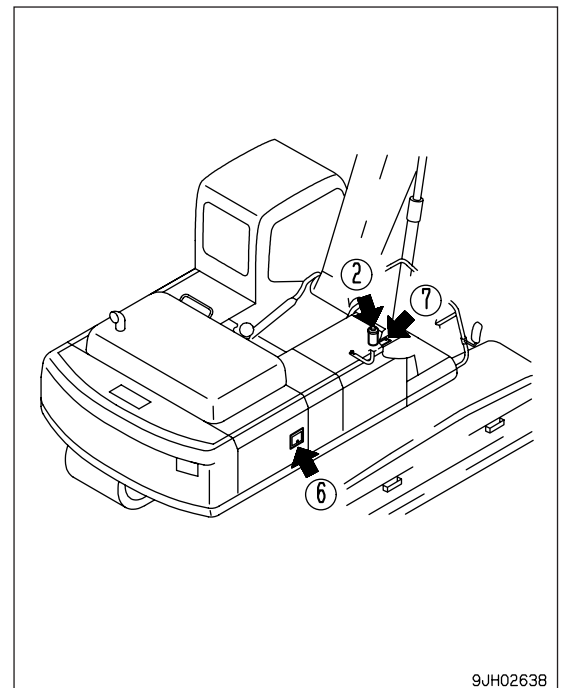
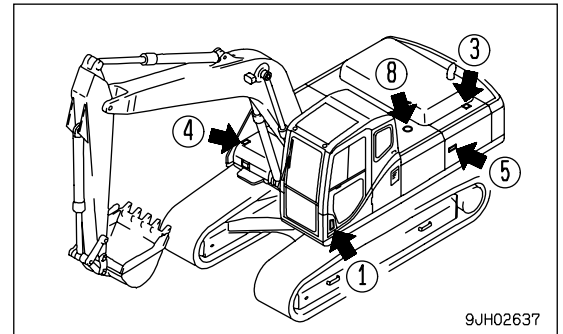

## LIFTING MACHINE

### WARNING

- The operator carrying out the lifting operation using a crane must be a properly qualified crane operator.
- Never raise the machine with any worker on it.
- Always make sure that the wire rope is of ample strength for the weight of this machine.
- When lifting, keep the machine horizontal.
- When carrying out lifting operations, set the lock lever to the LOCK position to prevent the machine from moving unexpectedly.
- Never enter the area under or around a raised machine.

Never try to lift the machine in any posture other than the posture given in the procedure below or using lifting equipment other than in the procedure below.

There is a hazard that the machine may lose its balance.

### NOTICE

The lifting procedure applies to machines with standard specifications.

The method of lifting differs according to attachments and options actually installed on the machine. For the proper lifting procedures, contact your Komatsu distributor.

For details of the weight, see "SPECIFICATIONS (PAGE 5-2)".

When lifting the machine, carry out the operation on flat ground as follows.

1. Start the engine, then swing the upper structure so that the work equipment will be on the side of sprocket (1).
2. Extend the bucket cylinder and arm cylinder fully, then lower the work equipment to the ground as shown in the diagram on the right using the boom cylinder.

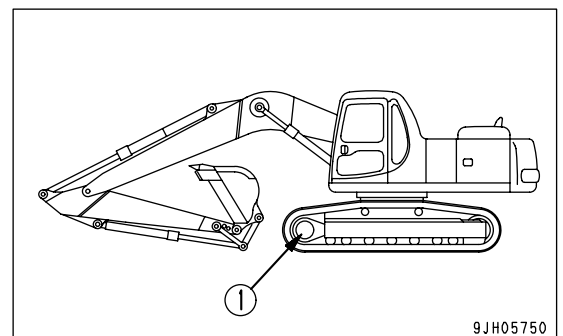

3. Set the lock lever securely to the LOCK position (L).

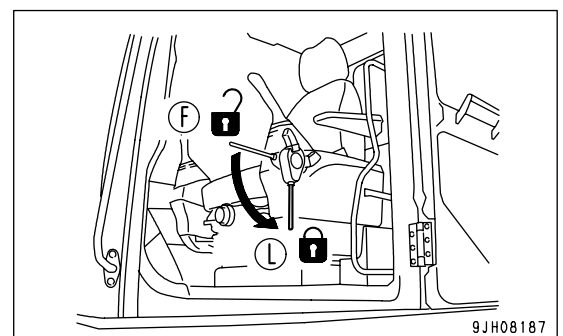

4. Stop the engine, check that there is nothing around the operator's compartment, then get off the machine. Close the cab door and front glass securely.

CLICK HERE TO **DOWNLOAD** THE COMPLETE MANUAL

- Thank you very much for reading the preview of the manual.
- You can download the complete manual from: [www.heydownloads.com](http://www.heydownloads.com) by clicking the link below



- Please note: If there is no response to CLICKING the link, please download this PDF first and then click on it.

CLICK HERE TO **DOWNLOAD** THE COMPLETE MANUAL

## DISCHARGED BATTERY

### WARNING

- It is dangerous to charge the battery while it is still mounted on the machine. Always remove the battery before charging it.
- When checking or handling the battery, stop the engine and turn the starting switch key to the OFF position.
- The battery generates hydrogen gas, so there is a hazard of explosion. Do not bring lighted cigarettes near the battery, or do anything that will cause sparks.
- Battery electrolyte is dilute sulphuric acid, and it will attack your clothes and skin. If it gets on your clothes or on your skin, wash it immediately off with large amounts of water. If it gets in your eyes, wash it out with fresh water, and consult a doctor.
- When handling batteries, always wear protective goggles and rubber gloves.
- When removing the battery, first disconnect the cable from the ground (normally the negative (-) terminal). When installing, install the positive (+) terminal first. If a tool touches the positive terminal and the chassis, there is danger that it will cause a spark, so be extremely careful.
- If the terminals are loose, there is danger that the defective contact may generate sparks that will cause an explosion.
- When installing the terminals, install them tightly. When removing or installing the terminals, check which is the positive (+) terminal and which is the negative (-) terminal.
- Green rust around the terminals is a cause of self-discharge of the battery. Polish the terminals with sandpaper. After removing the rust, coat the terminals thinly with grease before installing.

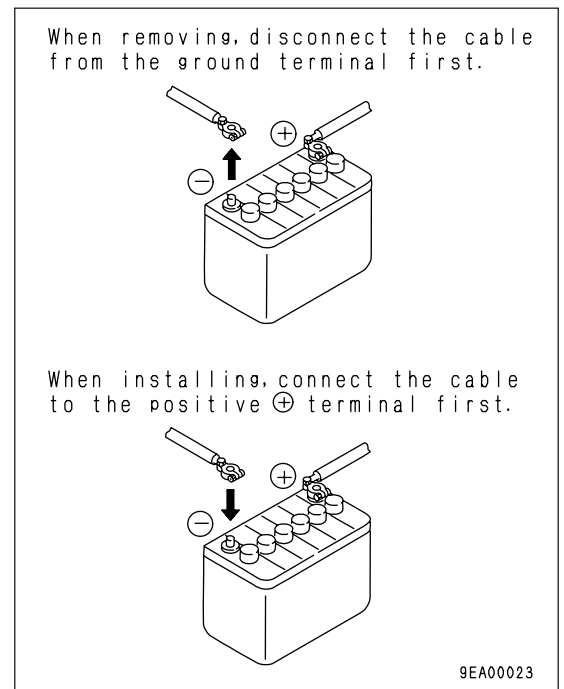

# MAINTENANCE INFORMATION

Do not carry out any inspection and maintenance operation that is not found in this manual.

## SERVICE METER READING

Check the service meter reading every day to see if the time has come for any necessary maintenance to be carried out.

## KOMATSU GENUINE REPLACEMENT PARTS

Use Komatsu genuine parts specified in the Parts Book as replacement parts.

## KOMATSU GENUINE LUBRICANTS

Use Komatsu genuine oils and grease. Choose oils and grease with proper viscosities specified for ambient temperature.

## WINDSHIELD WASHER FLUID

Use automobile windshield washer fluid, and be sure not to let any dirt get into it.

## FRESH AND CLEAN LUBRICANTS

Use clean oil and grease. Also, keep the containers of the oil and grease clean. Keep foreign materials away from oil and grease.

## CHECK DRAINED OIL AND USED FILTER

After oil is changed or filters are replaced, check the old oil and filters for metal particles and foreign materials. If large quantities of metal particles or foreign materials are found, always report to the person in charge, and carry out suitable action.

## FUEL STRAINER

If your machine is equipped with a fuel strainer, do not remove it while fueling.

## WELDING INSTRUCTIONS

- Turn off the engine starting switch.
- Do not apply more than 200V continuously.
- Connect grounding cable within 1m (3.3 ft) from the area to be welded. If grounding cable is connected near instruments, connectors, etc., the instruments may have troubles.
- Avoid seals or bearings from being between the area to be welded and the position of grounding point.
- Do not use the area around the work equipment pins or the hydraulic cylinders as the grounding point.

# RECOMMENDED FUEL, COOLANT AND LUBRICANTS

- Komatsu genuine oils are adjusted to maintain the reliability and durability of Komatsu construction equipment and components.

In order to keep your machine in the best conditioner for long periods of time, it is essential to follow the instructions in this Operation and Maintenance Manual.

- Failure to follow these recommendations may result in shortened life or excess wear of the engine, power train, cooling system, and/or other components.
- Commercially available lubricant additives may be good for the machine, but they may also cause harm.

Komatsu does not recommend any commercially available lubricant additive.

- Use the oil recommended according to the ambient temperature in the chart below.
- Specified capacity means the total amount of oil including the oil in the tank and the piping. Refill capacity means the amount of oil needed to refill the system during inspection and maintenance.
- When starting the engine in temperatures below 0°C (32°F), be sure to use the recommended multi-grade oil, even if the ambient temperature may become higher during the course of the day.
- If the machine is operated at a temperature below -20°C (-4°F), a separate device is needed, so consult your Komatsu distributor.
- When the fuel sulfur content is less than 0.5%, change the engine oil according to the period inspection table given in this Operation and Maintenance Manual.

If the fuel sulfur content is more than 0.5%, change the oil according to the following table.

Fuel sulfur content	Engine oil change interval
0.5 to 1.0%	1/2 of regular interval
Above 1.0%	1/4 of regular interval

# MAINTENANCE PROCEDURE

## INITIAL 250 HOURS MAINTENANCE (ONLY AFTER THE FIRST 250 HOURS)

Carry out the following maintenance only after the first 250 hours of operation on new machines.

- Replace fuel filter cartridge

Special tools are needed for inspection and maintenance, so contact your Komatsu distributor.

For details of the method of replacing or maintaining, see the section on EVERY 500 HOURS and 2000 HOURS SERVICE.

## INITIAL 1000 HOURS MAINTENANCE (ONLY AFTER THE FIRST 1000 HOURS)

Carry out the following maintenance only after the first 1000 hours of operation on new machines.

- Check engine valve clearance, adjust

Special tools are needed for inspection and maintenance, so contact your Komatsu distributor.

For details of the method of replacing or maintaining, see the section on EVERY 2000 HOURS SERVICE.

## CHECK AND ADJUST TRACK TENSION

### WARNING

For details of starting the engine and operating the work equipment, see "BEFORE STARTING ENGINE (PAGE 3-59)", "STARTING ENGINE (PAGE 3-73)", "AFTER STARTING ENGINE (PAGE 3-77)", and "WORK EQUIPMENT CONTROLS AND OPERATIONS (PAGE 3-90)" in the OPERATION section.

The wear of the pins and bushings on the undercarriage will vary with the working conditions and type of soil, so inspect the track tension frequently in order to maintain the standard tension. Stop the machine on firm, horizontal ground when carrying out the inspection and maintenance.

#### Checking

1. Run the engine at low idling, move the machine forward a distance equal to the length of track on ground, then stop the machine.
2. Choose wooden block (3) that will reach from idler (1) to carrier roller (2), then place it on top of the track.
3. Measure the maximum deflection between the top surface of the track and the bottom surface of the wooden block.
  - Standard deflection  
Deflection "a" should be 10 to 30 mm (0.4 to 1.2 in).

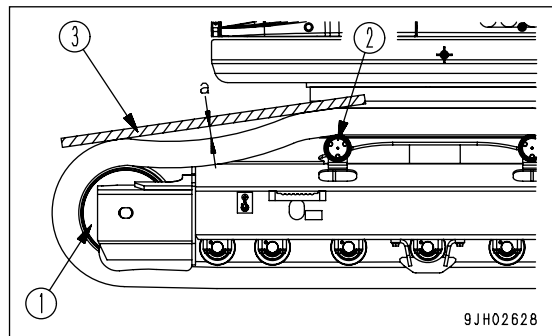

If the track tension is not at the standard value, adjust it in the following manner.

## CHECK AND ADJUST AIR CONDITIONER (ONLY MACHINES EQUIPPED WITH AIR CONDITIONER)

### CHECK LEVEL OF REFRIGERANT (GAS)

**⚠ WARNING**

If the refrigerant used in the cooler gets into your eyes or on your hands, it may cause loss of sight or frostbite. Do not touch the refrigerant. Never loosen any part of the refrigerant circuit.  
Do not bring any flame close to any point where the refrigerant gas is leaking.

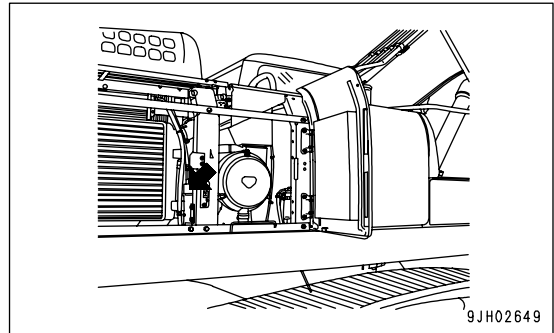

If there is a lack of refrigerant (Freon 134a), the cooling performance will be poor.

When operating the cooler at high speed, there should be no bubbles in the sight glass (inspection window) mounted on the condenser unit receiver.

- No bubbles in refrigerant flow: Correct
- Bubbles in refrigerant flow (bubbles continuously pass through): Refrigerant level low
- Colorless, transparent: No refrigerant

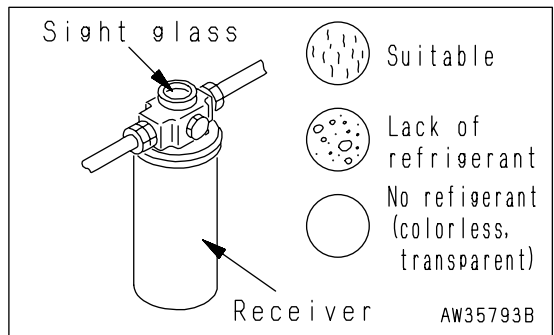

**REMARK**

When there are bubbles, the refrigerant gas level is low, so contact your refrigerant dealer to have refrigerant added. If the air conditioner is run with the refrigerant gas level low, it will cause damage to the compressor.

**Check in off-season**

When not being used for a long period, operate the cooler for 3 to 5 minutes once a month to supply lubricant to each component of the compressor.

**Inspection and maintenance items list for cooler**

Inspection and maintenance items	Contents	Maintenance interval
Refrigerant (gas)	Filling quantity	Twice a year; spring and autumn
Condenser	Clogging of fin	Every 500 hours
Compressor	Function	Every 4000 hours
V belt	Damage and tension	Every 250 hours
Blower motor and fan	Function (Check for abnormal sound)	When required
Control mechanism	Function (Check for normal function)	When required
Piping for connection	Installation condition looseness of tightening connection portions gas leakage, damage	When required

(6) Boom cylinder foot pin (2 places)

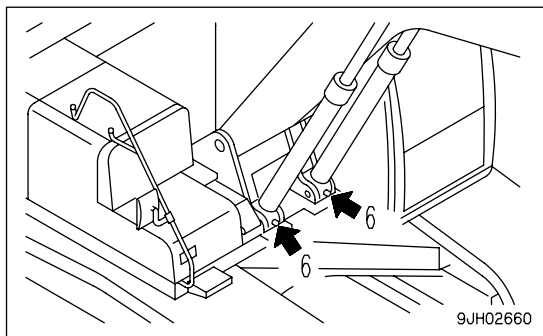

(7) Boom foot pin (2 places)

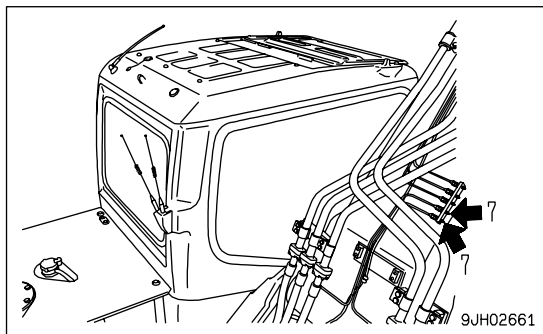

6. After replacing the filter cartridge, open the engine hood and add engine oil through oil filler (F) to between the H and L marks on dipstick (G).
7. Run the engine at idling for a short time, then stop the engine and check again that the oil level is between the H and L marks on dipstick (G).  
For details, see "CHECK OIL LEVEL IN ENGINE OIL PAN, ADD OIL (PAGE 3-62)".
8. Install the undercover.

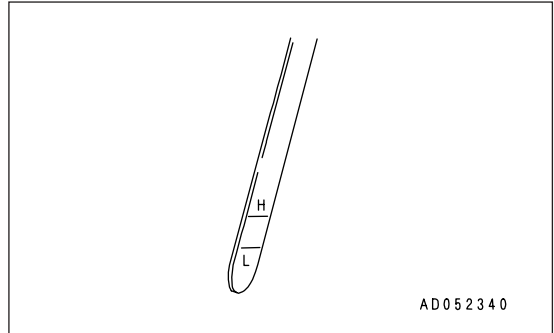

## EVERY 2000 HOURS MAINTENANCE

Maintenance for every 50, 100, 250, 500 and 1000 hours service should be carried out at the same time.

### CHANGE OIL IN FINAL DRIVE CASE

**⚠ WARNING**

- The oil is at high temperature after the engine is stopped. Wait for the temperature to go down before starting the operation.
- If there is pressure remaining inside the case, the oil or plug may fly out. Loosen the plug slowly to release the pressure.

- Refill capacity (each): 8.5 liters (2.25 US gal)
  - Hexagon wrench
1. Set the final drive the way TOP mark comes to the top and the mark and plug (P) are perpendicular to the ground.
  2. Set a container under plug (P) to catch the oil.
  3. Remove plugs (P) and (F) with the hexagon wrench and drain the oil.

**REMARK**

Check the O-rings in the plugs for damage. If necessary, replace with new ones.

4. Tighten plug (P).
5. Add engine oil trough the hole of plug (F).
6. When the oil overflows from the hole of plug (F), install plug (F).  
Plugs (P) and (F) are tightened to the torque of  $68.6 \pm 9.8 \text{ N}\cdot\text{m}$  ( $7 \pm 1 \text{ kgf}\cdot\text{m}$ ,  $50.6 \pm 7.2 \text{ lbf}\cdot\text{ft}$ ).

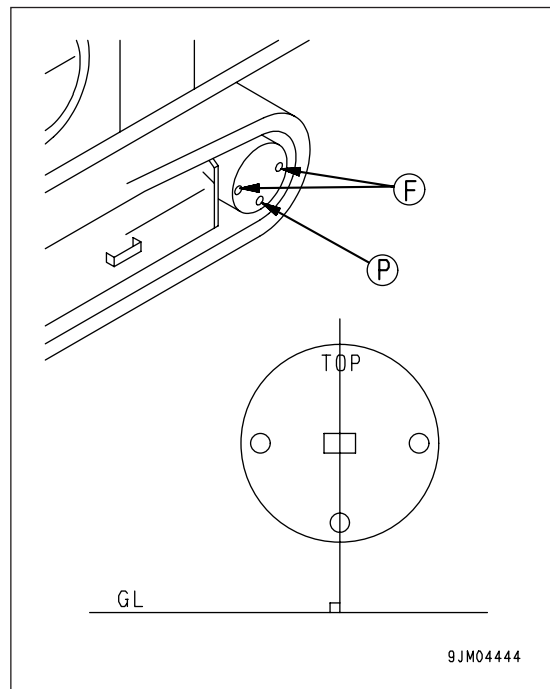

**REMARK**

There are two plugs (F). Add oil through the one easier to fill oil and through which no internal gears are to be seen.

**⚠ WARNING****Precautions for removal and installation operations**

When removing or installing the attachment, always do as follows to ensure safety in the operation.

- Carry out the removal and installation operation on firm, level ground.
- When carrying out the operation with two or more workers, determine the signals and follow these during the operation.
- Always use a crane when you lift or carrying heavy objects (more than 25kg or 55 lb).
- When removing heavy components, always support the component before removing it. When lifting with a crane, be particularly careful about the position of the center of gravity.
- It is dangerous to carry out operations with a load left raised by a crane. Always prepare a stand and ensure that the condition is safe.
- When leaving an attachment removed or when installing the attachment, make sure that it is in a stable condition and cannot fall over.
- Never go under a load raised by a crane. Stay in a safe place where there is no danger if the load should fall.

**NOTICE**

Qualifications are required to operate a crane. Never allow the crane to be operated by an unqualified person.

For details of removal and installation operations, contact your Komatsu distributor.

# ATTACHMENT MOUNTING/DISMOUNTING PROCEDURE

## DISMOUNTING PROCEDURE

1. Place the attachment on the ground and stop the engine.
2. Turn the starting switch to ON position and push down the lock lever to FREE position.
3. Operate each work equipment control lever and the attachment control pedal back and forth, left and right at full stroke 2 to 3 times to eliminate the internal pressure in the hydraulic circuit.

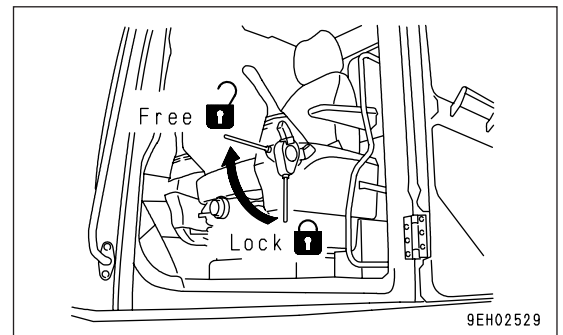
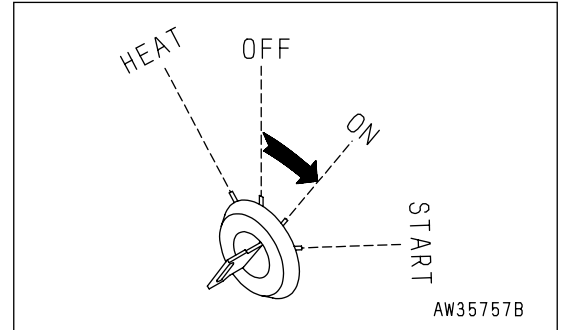

4. Loosen slowly oil filler cap (F) on top of the hydraulic tank to eliminate the internal pressure in the hydraulic circuit.

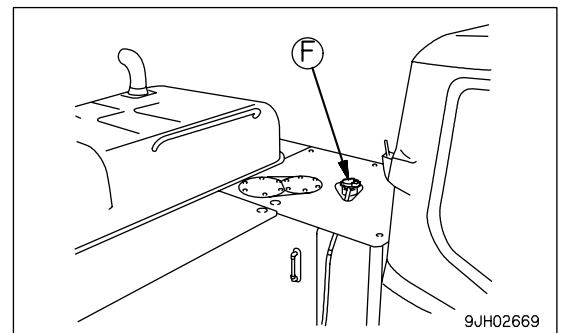

5. After confirming low oil temperature, turn the rotor of the stop valve connected to the inlet and outlet piping on the arm side face toward the lock side.
6. Remove the hoses on the attachment side. Install the blind plugs to the two outlets.

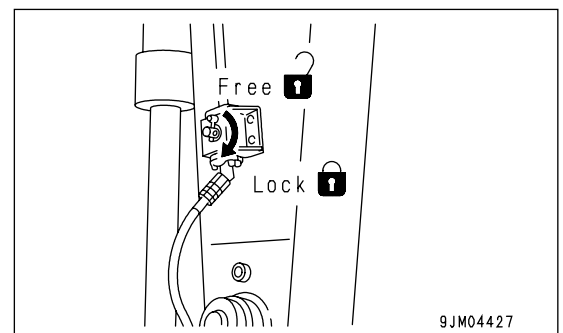

The blind plugs are used to prevent the attachment from incorrect operation caused by mixing in of foreign matter. After the plugs are correctly installed, store the attachment.

## SELECTING TRACK SHOE

Select the appropriate track shoe to match the operating conditions.

### METHOD OF SELECTING TRACK SHOE

Check the category from the usage table below and select the track shoe from the table at the bottom.

- Use category B is for wide shoes. There are limits for the use of wide shoes, so check carefully when using. Investigate the conditions of use carefully and consider the situation to select the most suitable track shoe.
- When selecting the shoe width, shoe possible that will cause no problem within the range for flotation and ground contact pressure of the machine. If a larger width of the necessary is used, there will be a greater load on the track shoe, and this will cause problems such as bending of the track shoes, cracking of the links, breakage of pins, and loosening of shoe bolts.

**Table 1**

Category	Use	Precautions for use
A	Rocky ground, riverbeds, normal soil	● On rough ground where there are large obstacles such as boulders or fallen trees, travel at Lo speed.
B	Normal soil, soft ground precautions for use	<ul style="list-style-type: none"> <li>● These shoes cannot be used on rough ground where there are large obstacles such as boulders or fallen trees.</li> <li>● Travel at Hi speed only on flat ground, and if it is impossible to avoid going over obstacles, shift down and travel at half speed in Lo.</li> </ul>
C	Paved road surface	● Be careful on slopes. Flat shoes have low gradeability

**Table 2**

	PC300-7		PC350-7		PC300LC-7		PC350LC-7	
	Specifications	Category	Specifications	Category	Specifications	Category	Specifications	Category
Standard	600mm Triple	A	600mm Triple	A	700mm Triple	B	600mm Triple	A
Option	700mm Triple	B	700mm Triple	B	600mm Triple	A	700mm Triple	B
Option	800mm Triple	B			800mm Triple	B		
Option	700mm Flat	C			700mm Flat	C		

## BASIC OPERATION OF MACHINE MONITOR

### If there is abnormality when starting engine

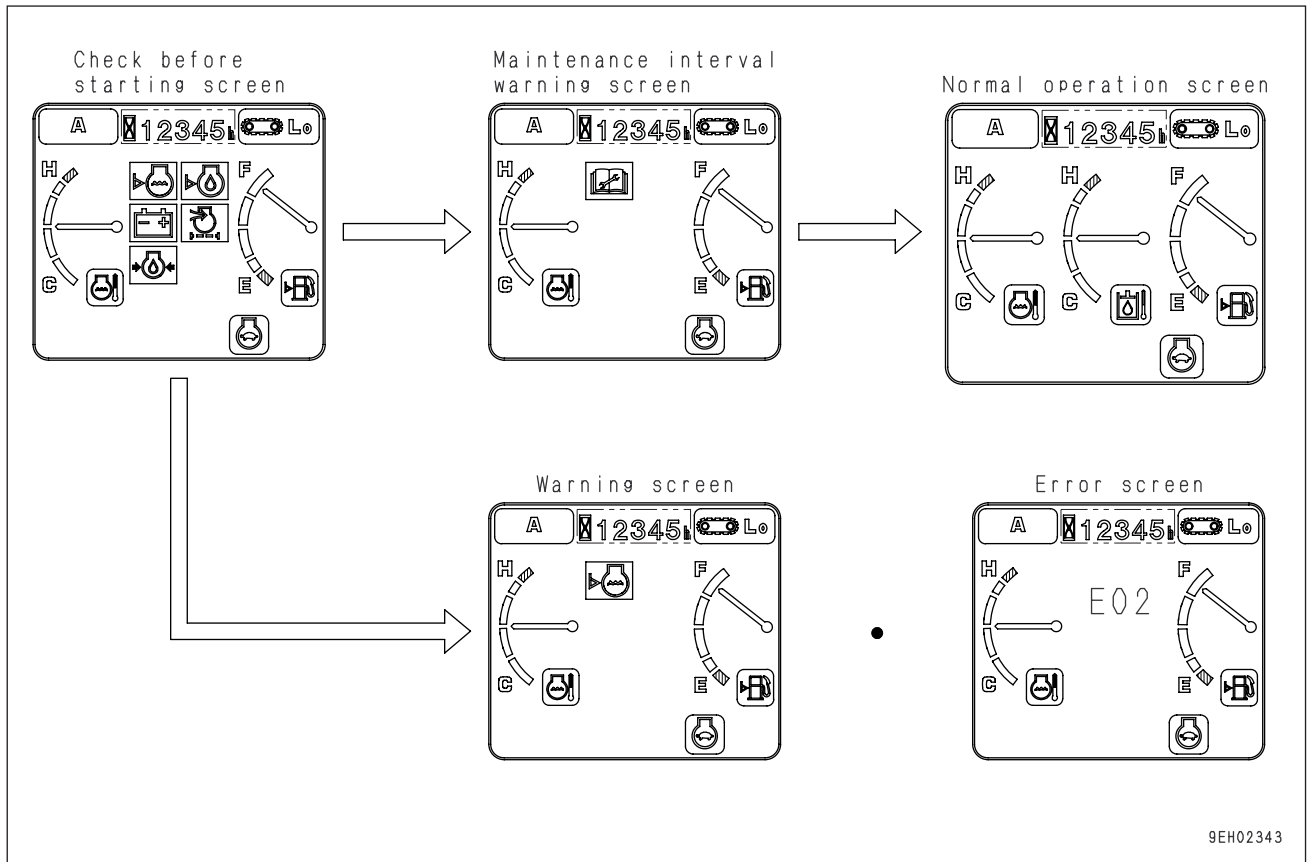

- If there is any abnormality when starting the engine, the check before starting screen changes to the maintenance interval warning screen, warning screen, or error screen.
- After displaying the check before starting screen for 2 seconds, the screen changes to the maintenance interval warning screen.
- After displaying the maintenance interval warning screen for 30 seconds, the screen returns to the normal screen.
- After displaying the check before starting screen for 2 seconds, the screen changes to the warning screen or error screen.

**TRAVEL SPEED MONITOR**

This monitor (6) displays the set mode for the travel speed.

The monitor display when the travel speed selector switch is operated is as follows.

- Lo : Low speed
- Mi : Medium speed
- Hi : High speed

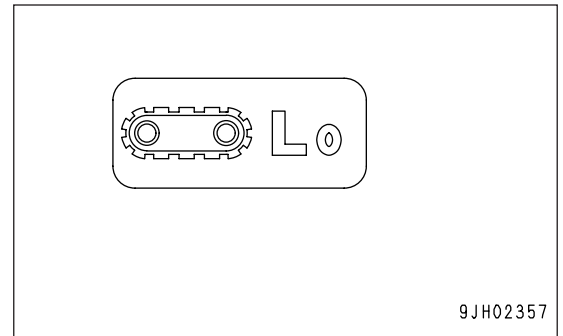

9JH02357

**ONE TOUCH POWER UP MONITOR**

This monitor (7) shows if the power max function is being actuated.

The monitor display when the knob switch on the left control lever is operated is as follows.

Monitor lights up: Digging power is increased while knob switch is kept pressed.

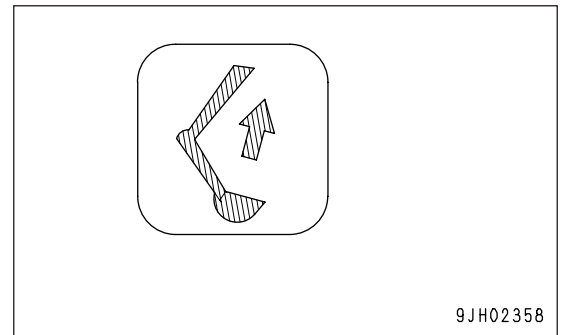

9JH02358

**REMARK**

The digging power is increased while the knob switch is being pressed only for working modes A and E. Note that even if the knob switch is kept pressed, the increase in power ends after 8.5 seconds.

Monitor goes out : Power max function stopped

**METERS**

**ENGINE WATER TEMPERATURE GAUGE**

This meter (8) indicates the engine cooling water temperature.

During normal operations, the indicator should be in the black range. If the indicator enters the red range during operations, the overheat prevention system is actuated.

The overheat prevention system acts as follows.

- Red range position (A) :  
Engine water temperature monitor (1) lights up red
- Red range position (B) :  
Engine speed is reduced to low idling, engine water temperature monitor lamp (C) lights up red, and the alarm buzzer sounds at same time.

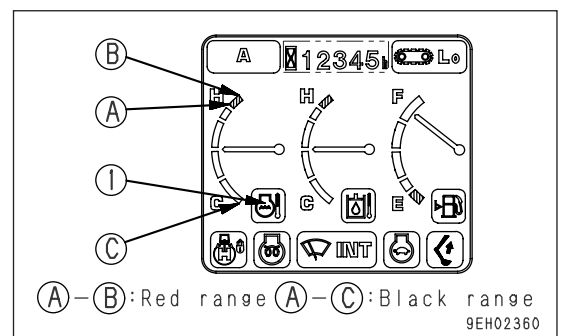

9EH02360

The overheat prevention system remains actuated until the indicator returns to the black range.

When the engine is started, if the indicator is at position (C), engine water temperature monitor (1) lights up white.

In this case, carry out the warming-up operation. For details, see "WARMING-UP OPERATION (PAGE 7-35)".

### BACK SWITCH

Press this switch (8) when in the maintenance mode, brightness/contrast adjustment mode, or select mode. The screen will return to the previous screen on the monitor display.

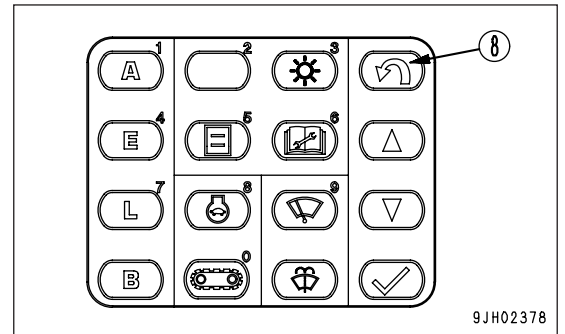

### UP SWITCH, DOWN SWITCH

Press up switch (9) or down switch (10) when in the maintenance mode, brightness/contrast adjustment mode, or select mode to move the cursor on the monitor display (colors of selected monitor are inverted) up, down, left, or right.

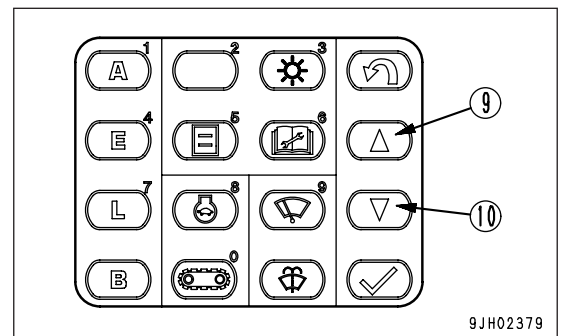

### INPUT CONFIRMATION SWITCH

Press this switch (11) to confirm the selected mode when in the maintenance mode, brightness/contrast adjustment mode, or select mode.

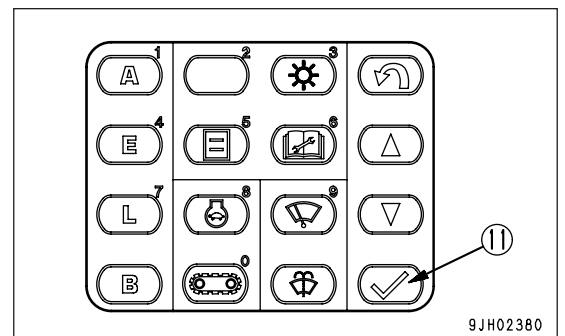

## AFTER STARTING ENGINE

### ⚠ WARNING

- **Emergency stop**  
If there has been any abnormal actuation or trouble, turn the starting switch key to the OFF position.
- If the work equipment is operated without warming the machine up sufficiently, the response of the work equipment to the movement of the control lever will be slow, and the work equipment may not move as the operator desires, so always carry out the warming-up operation. Particularly in cold areas, be sure to carry out the warming-up operation fully.

## WARMING-UP OPERATION

### NOTICE

- When the hydraulic oil is at a low temperature, do not carry out operations or move the levers suddenly. Always carry out the warming-up operation. This will help to extend the machine life.
- Do not suddenly accelerate the engine before the warming-up operation is completed.  
Do not run the engine at low idling or high idling continuously for more than 20 minutes. This will cause leakage of oil from the turbocharger oil supply piping. If it is necessary to run the engine at idling, apply a load from time to time or run the engine at a mid-range speed.

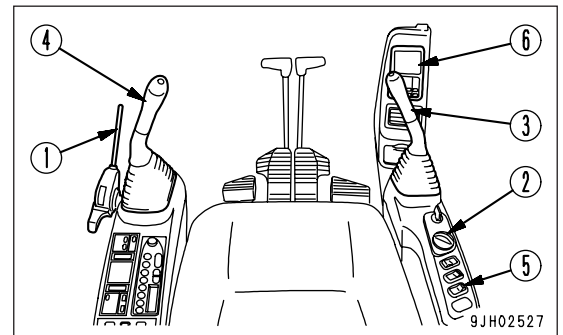

### REMARK

- If the engine water temperature is above 30°C, to protect the turbocharger, the engine speed does not rise for 2 seconds after starting, even if the fuel control dial is turned.
- If the hydraulic oil temperature is low, the hydraulic oil temperature monitor display will be white.

## MOVING MACHINE BACKWARD

1. Set lock lever (4) to the FREE position, set the work equipment to the travel posture, then raise 40 - 50 cm (16 - 20 in) above the ground.

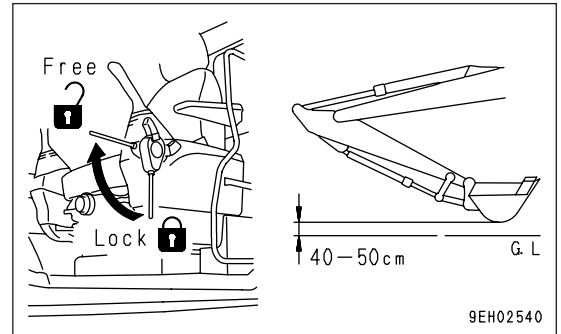

2. Operate right and left travel levers (5) or right and left travel pedals (6) as follows.

- When the sprocket is at the rear of the machine

Pull levers (5) backward slowly or depress the rear part of pedals (6) to move the machine off.

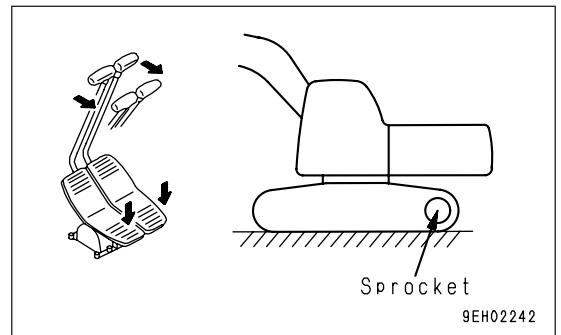

- When the sprocket is at the front of the machine

Push levers (5) forward slowly or depress the front part of pedals (6) to move the machine off.

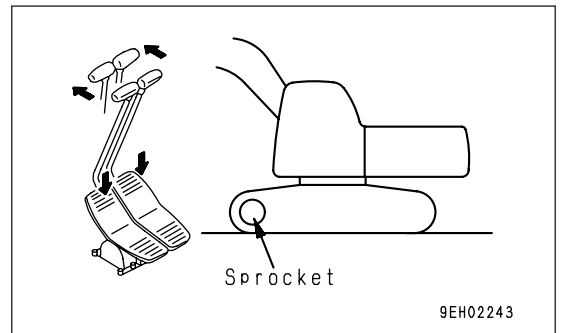

3. Check that the alarm sounds properly when the machine moves off. If the alarm does not sound, please ask your Komatsu distributor to carry out repairs.

### REMARK

In cold temperatures, if the machine travel speed is not normal, carry out the warming-up operation thoroughly. In addition, if the undercarriage is clogged with mud and the machine travel speed is not normal, remove the soil and mud from the undercarriage.

**REARVIEW MIRRORS**

The mirrors are at the positions shown in the diagram on the right.

If they are damaged, or are to be removed for shipment, or are to be installed again, use the following procedure.

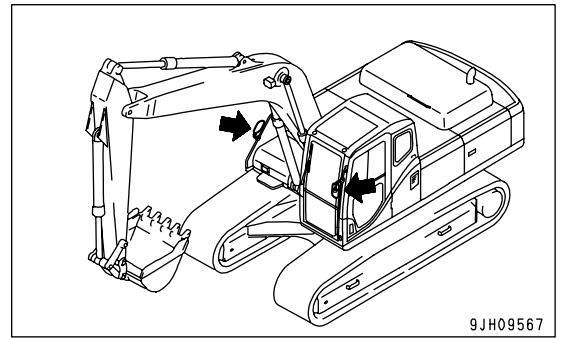

**Removal**

● Left mirrors

1. Loosen locknut (2) of mirror (1), then remove mirror (1) from support (3).
2. Loosen bolt (4), then remove support (3) and clamp (5) from the handrail.

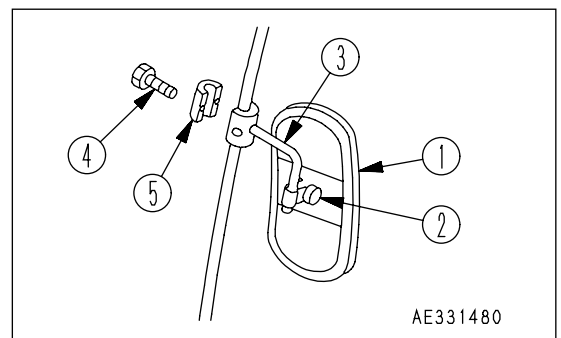

● Right mirror

3. Loosen locknut (2) of mirror (1), then remove mirror (1) from support (3).
4. Loosen bolt (4) and remove support (3) and clamp (5) from the handrail.

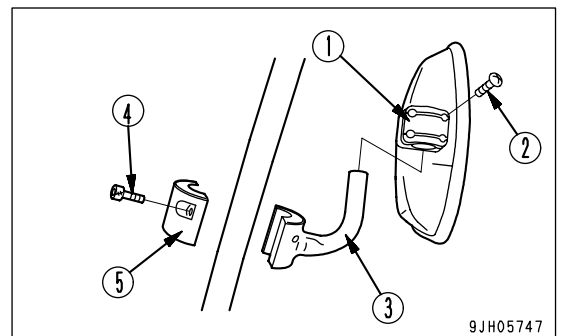

**Installation**

● Left mirrors

1. Install support (3) and clamp (5) to the handrail, then tighten bolt (4).
2. Install mirror (1) to support (3), then tighten locknut (2).

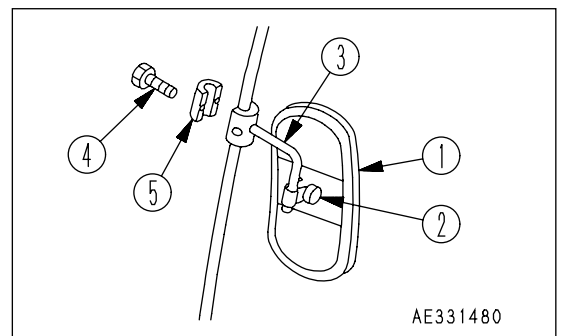

CLICK HERE TO **DOWNLOAD** THE COMPLETE MANUAL

- Thank you very much for reading the preview of the manual.
- You can download the complete manual from: [www.heydownloads.com](http://www.heydownloads.com) by clicking the link below



- Please note: If there is no response to CLICKING the link, please download this PDF first and then click on it.

CLICK HERE TO **DOWNLOAD** THE COMPLETE MANUAL