

Operation & Maintenance Manual

PC1800-6

HYDRAULIC EXCAVATOR

SERIAL NUMBERS **PC1800-6 -10002** and up

This material is proprietary to Komatsu Mining Systems and is not to be reproduced, used, or disclosed except in accordance with written authorization from Komatsu Mining Systems.

It is our policy to improve our products whenever it is possible and practical to do so. We reserve the right to make changes or add improvements at any time without incurring any obligation to install such changes on products sold previously.

Due to this continuous program of research and development, periodic revisions may be made to this publication. It is recommended that customers contact their distributor for information on the latest revision.

CLICK HERE TO **DOWNLOAD** THE COMPLETE MANUAL

- Thank you very much for reading the preview of the manual.
- You can download the complete manual from: www.heydownloads.com by clicking the link below



- Please note: If there is no response to CLICKING the link, please download this PDF first and then click on it.

CLICK HERE TO **DOWNLOAD** THE COMPLETE MANUAL

ALWAYS APPLY LOCK WHEN LEAVING OPERATOR'S SEAT

- When standing up from the operator's seat, always place the safety lock levers ① securely in the LOCK position. If you accidentally touch the levers when they are not locked, the work equipment may suddenly move and cause serious injury or damage.
- When leaving the machine, lower the blade and ripper completely to the ground, set the safety lock levers ① to the LOCK position, then stop the engine. Use the key to lock all the equipment. Always remove the key and take it with you.

Work equipment posture → See "12.16 PARKING MACHINE".

Locking → See "12.20 LOCKING"

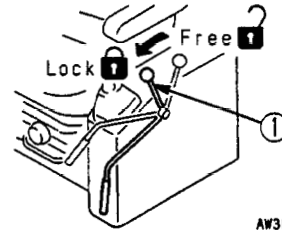

MOUNTING AND DISMOUNTING

- Never jump on or off the machine. Never get on or off a moving machine.
- When getting on or off the machine, always face the machine and use the handrails and steps.
- Never hold any control levers or lock levers when getting on or off the machine.
- To ensure safety, always maintain three-point contact (both feet and one hand, or both hands and one foot) with the handrails and steps to ensure that you support yourself.
- If there is any oil, grease, or mud on the handrails or steps, wipe it off immediately. Always keep these parts clean. Repair any damage and tighten any loose bolts.
- When getting on or off the machine, or when moving along the top of the track, if you hold the handrail inside the door when moving on top of the track shoe, and the door lock is not locked securely, the door may move and cause you to fall. Always lock the door securely.

Method of locking door → See "11.4 DOOR LOCK".

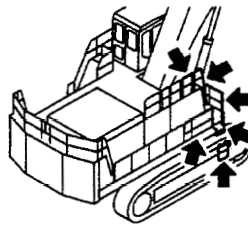
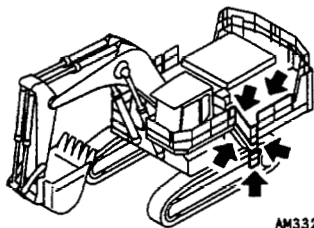

▲ WARNING: Failure to follow these safety precautions may lead to a serious accident.

7. PRECAUTIONS DURING OPERATION

TRAVELING ON SLOPES

- Traveling on slopes could result in the machine tipping over or slipping to the side.
- When traveling on slopes, keep the blade approximately 20 – 30 cm (8 – 12 in) above the ground. In case of emergency, quickly lower the bucket to the ground to help the machine to stop.
- Do not turn on slopes or travel across slopes. Always go down to a flat place to perform these operations.

Method of traveling on slopes → See "12.12 PRECAUTIONS WHEN TRAVELING UP OR DOWN HILLS".

- Do not travel on grass, fallen leaves, or wet steel plates. Even slight slopes may cause the machine to slip to the side, so travel at low speed and make sure that the machine is always traveling directly up or down the slope.
- If the engine stops on a slope, place the travel lever at the neutral position and lower the bucket to the ground. Do not operate the steering. There is danger that the machine will turn under its own weight.

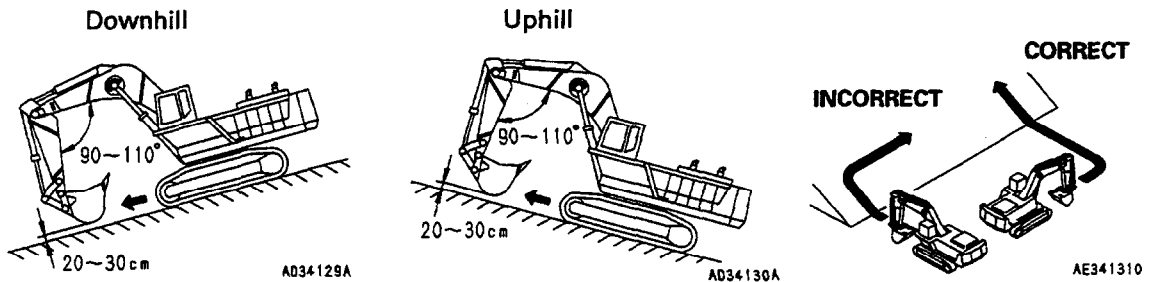

PROHIBITED OPERATIONS

- Do not dig the work face under an overhang. This may cause the overhang to collapse and fall on top of the machine.
- Do not carry out deep digging under the front of the machine. The ground under the machine may collapse and cause the machine to fall. Take emergencies into consideration and set with the travel motor at the rear and the track (undercarriage) at right angles to the road shoulder before digging to enable the machine to move back quickly. If the ground under the machine collapses and there is no time to drive in reverse, do not suddenly raise the arm and boom. In some cases, it may in fact be safer to lower the arm and boom.
- Do not swing the work equipment to the side when it is carrying a heavy load. The stability to the side is less than the stability to the front, so there is danger that the machine may turn over.
- Limits on use

To prevent accidents caused by breakage of the work equipment or tipping over of the machine under excessive load, do not use the machine in excess of its capacity. Always be sure to keep within the maximum specified load and safe angle determined for the structure.

INCORRECT

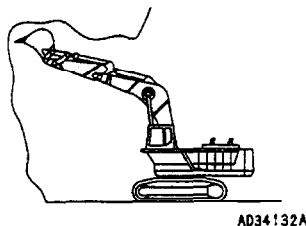

INCORRECT

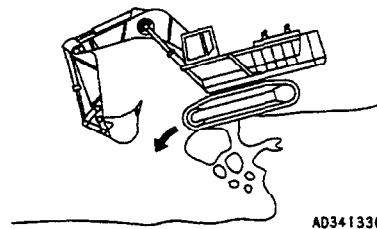

▲ WARNING: Failure to follow these safety precautions may lead to a serious accident.

8. PRECAUTIONS FOR MAINTENANCE

KEEP WORK PLACE CLEAN AND TIDY

Do not leave hammers or other tools lying around in the work place. Wipe up all grease, oil, or other substances that will cause you to slip. Always keep the work place clean and tidy to enable you to carry out operations safely.

If the work place is not kept clean and tidy, there is danger that you will trip, slip, or fall over and injure yourself.

APPOINT LEADER WHEN WORKING WITH OTHERS

When repairing the machine or when removing and installing the work equipment, appoint a leader and follow his instructions during the operation.

When working with others, misunderstandings between workers can lead to serious accidents.

RADIATOR WATER LEVEL

- When inspecting the radiator water level, stop the engine, and wait for the engine and radiator to cool down. Check the water level in the sub-tank. Under normal conditions, do not open the radiator cap.
- If there is no sub-tank, or the radiator cap must be removed, always do as follows.
- Wait for the radiator water temperature to go down before checking the water level. (When checking if the water temperature has gone down, put your hand near the engine or radiator and check the air temperature. Be careful not to touch the radiator or engine.)
- Release the internal pressure before removing the radiator cap, and remove the radiator cap slowly.



A0055050



A0067380

STOP ENGINE BEFORE CARRYING OUT INSPECTION AND MAINTENANCE

- When carrying out inspection and maintenance, park the machine on level ground where there is no danger of falling rocks or land slides, or of flooding if the land is low, then lower the work equipment to the ground and stop the engine.
- Operate the right work equipment control lever several times to the RAISE and LOWER positions to release the remaining pressure in the hydraulic circuit, then set safety lock lever ① to the LOCK position.
- Put blocks under the track to prevent the machine from moving.
- The worker carrying out the maintenance should be extremely careful not to touch or get caught in the moving parts.

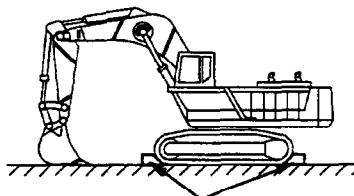

Blocks

AD34139A

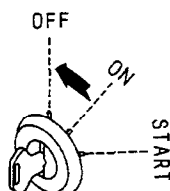

AW34987B

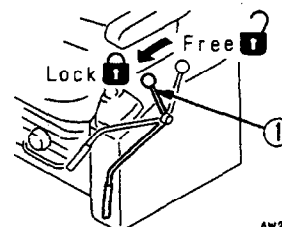

AW36415B

5. Warnings for hot oil hazard
(09653-03001)

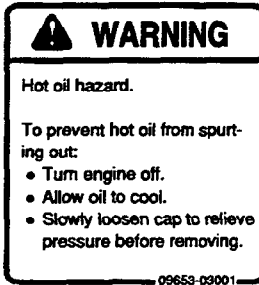

7. Warnings for handling accumulator
(09659-53000)



6. Warnings for hot water hazard
(09668-03001)

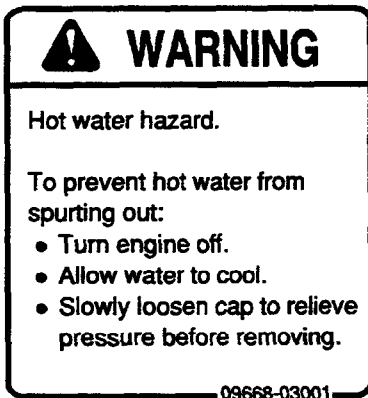

8. Warnings for adjusting track tension
(09657-03003)

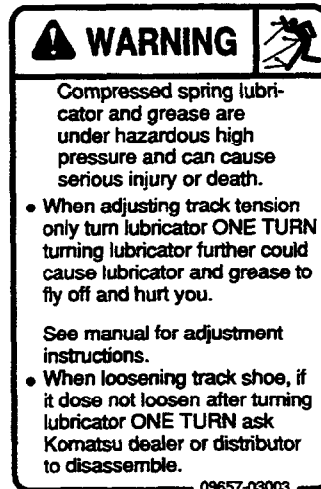

11. EXPLANATION OF COMPONENTS

11.1.2 B: CAUTION ITEMS

CAUTION

If the caution monitor lamp flashes, repair the problem as soon as possible.

1. CHARGE LEVEL

This monitor indicates an abnormality in the charging system while the engine is running.

If the monitor lamp flashes, check the V-belt tension. If any abnormality is found, see "16.6 OTHER TROUBLE".

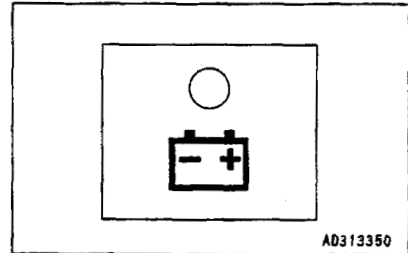

REMARK

While the starting switch is ON, the lamp will remain lit and will go off once the engine is started.

2. FUEL LEVEL

If the fuel drops below 169 liters (44.6 US gal, 37.5 UK gal), the lamp will flash. Top up the fuel before this.

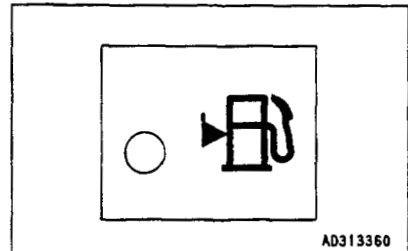

3. AIR CLEAN CLOGGING

If the air cleaner element clogged, the monitor lamp flashes. Stop the engine, check the air cleaner element and clean it.

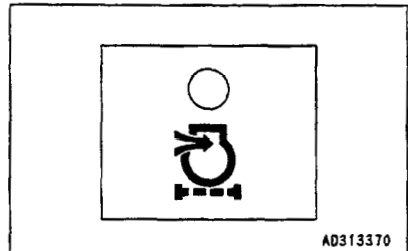

4. HYDRAULIC FILTER CLOGGING MONITOR

This monitor indicates clogging of the hydraulic filter.

If the monitor lamp flashes, stop the engine and check, clean the filter element.

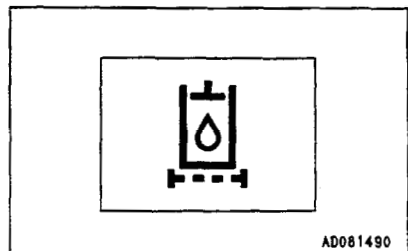

11. EXPLANATION OF COMPONENTS

14. ROTATING LAMP SWITCH

This lights up the rotating lamp.

ON position: Lamp lights up.

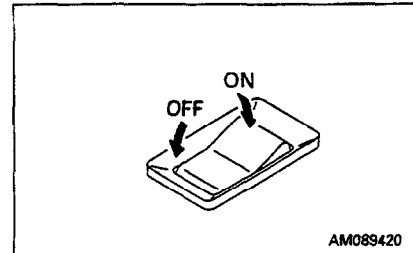

15. ALARM BUZZER STOP SWITCH

This is used to stop the alarm buzzer if it sounds to warn of an abnormality during operation.

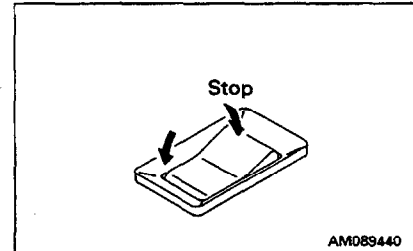

16. WIPER SWITCH

This actuates the wiper for the front glass.

- ① OFF: Wiper stops
- ② ON: Wiper moves continuously
- ③ Window washer fluid is sprayed out. When switch is released it returns to position ②.
- ④ ON: Wiper moves intermittently
- ⑤ Window washer fluid is sprayed out. When switch is released it returns to position ④.

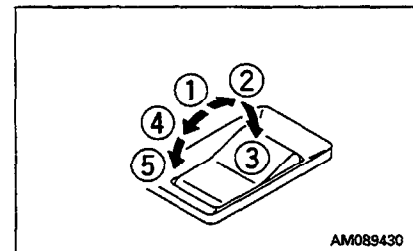

17. GREASING SWITCH

This actuates the grease pump.

- ① START: Greasing is started. When the switch is released, greasing will continue for 15 minutes and then stop.
- ② STOP: This switch is used to forcibly stop the grease pump during greasing operations.
- ③ Pilot lamp: This lights up when the grease pump is operating.

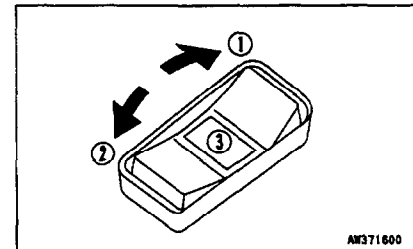

18. HORN SWITCH

Press the switch on the right work equipment control lever to sound the horn.

At the same time, the flashing light (option) at the top front of the cab will flash for approx. 5 seconds to give a signal to the dump truck.

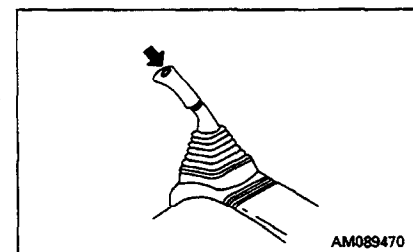

11. EXPLANATION OF COMPONENTS

5. AIR CONDITIONER SWITCH **A/C** (AIR CONDITIONER CONTROL PANEL 1 AND 2 THE SAME)

This is used to switch the air conditioner ON/OFF.

6. OFF SWITCH **OFF** (AIR CONDITIONER CONTROL PANEL 1 AND 2 THE SAME)

This switch is use to stop the fan.

7. DEFROSTER

This is used to clear the mist from the front glass in cold or rainy conditions.

- Open the defroster vent and adjust the direction so that the air blows on the front glass. (During normal operations, use with the defroster vent closed.)
- If it is desired to remove the mist quickly, close the other vents when using the defroster vent.

The defroster can be used under the following conditions:

When air conditioner control panel 1 vent selector is at 

When air conditioner control panel 2 vent selector is at 

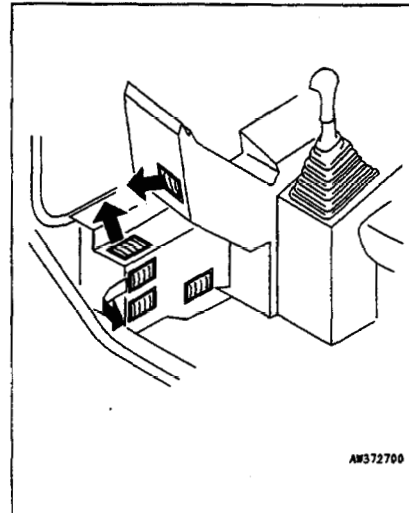

11.7.2 PRECAUTIONS WHEN USING AIR CONDITIONER

Carry out ventilation from time to time when using the cooler.

- If you smoke when the cooler is on, the smoke may start to hurt your eyes, so turn the lever to FRESH to remove the smoke while continuing the cooling.
- When running the air conditioner for a long time, turn the lever to the FRESH position once an hour to carry out ventilation and cooling.

Be careful not to make the temperature in the cab too low.

- When the cooler is on, set the temperature so that it feels slightly cool when entering the cab (5 – 6°C lower than the outside temperature). This temperature difference is considered to be the most suitable for your health, so always be careful to adjust the temperature properly.

11. EXPLANATION OF COMPONENTS

11.14 CIRCUIT-BREAKER (Installed outside cab)

If the engine does not start even when the starting switch is turned to the ON position, the electrical circuit has probably been cut by the circuit breaker. Open the side door closest to the front of the machine on the left side and check the breaker button under the battery.

If the button is protruding, push it in.

If the electrical circuit is working normally, the button will stay pushed in. If it springs out immediately after it is pushed in, it is necessary to check the electrical circuit.

REMARK

A circuit-breaker refers to the large-sized fuse breaker installed in the high current flow portion of the circuit to protect electrical components and wiring from burning, similarly to an ordinary fuse.

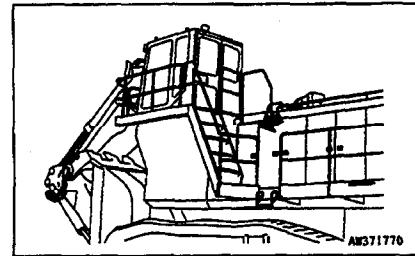

11.15 CONTROLLERS

The engine throttle and pump controller and the VHMS controller are installed inside the cab base.

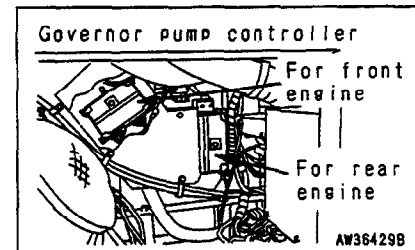

NOTICE

- Never splash or spill water, mud or drink over the controllers as this may cause a fault.
- If a fault occurs in the controller, do not attempt repair, but consult your Komatsu distributor.

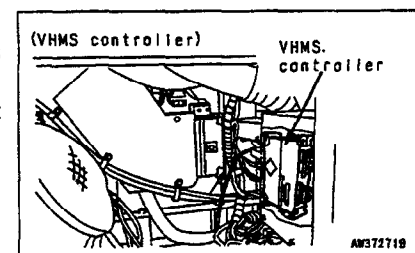

11.16 TOOL BOX

This is used for keeping the tools.

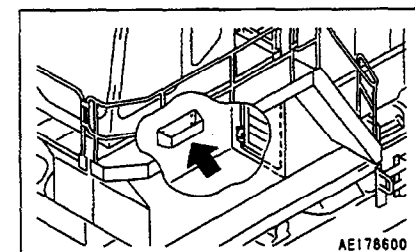

11. EXPLANATION OF COMPONENTS

- Ⓐ Maintenance items for every 250 h
 - Change oil in engine oil pan
 - Replace engine oil filter cartridge
 - Replace hydraulic filter element
 - Replace drain filter cartridge
 - Replace hydraulic tank breather filter element
- Ⓑ Maintenance items for every 500 h
 - Replace fuel filter
- Ⓒ Maintenance items for every 1000 h
 - Change oil in swing machinery case
 - Change oil in PTO case
 - Replace corrosion resistor cartridge
- Ⓓ Maintenance items for every 2000 h
 - Change oil in hydraulic tank
 - Wash engine breather element
 - Change oil in final drive case

This screen displays typical change and replacement items, but there are also other inspection and adjustment items. When carrying out maintenance, see the inspection and maintenance schedule chart in Section 23 of this manual.

- Ⓔ Normal screen display button: This switches to the normal screen. The item previously displayed on the normal screen is displayed.

CHECK OIL LEVEL IN HYDRAULIC TANK, ADD OIL

⚠ WARNING

- When removing the oil filler cap, oil may spurt out, so turn the cap slowly to release the internal pressure before removing the cap.
- If oil has been added to above the H mark, stop the engine and wait for the hydraulic oil to cool down, then drain the excess oil from the drain plug ⑥.

1. If the work equipment is not in the condition shown in the diagram on the right, start the engine, run the engine at low speed, retract the arm and bucket cylinders, then lower the boom, set the bucket teeth in contact with the ground, and stop the engine.
2. Within 15 seconds after stopping the engine, move each control lever (for work equipment and travel) to the full stroke in all directions to release the internal pressure.
3. Check sight gauge ③. The oil level is normal if between the H and L marks.

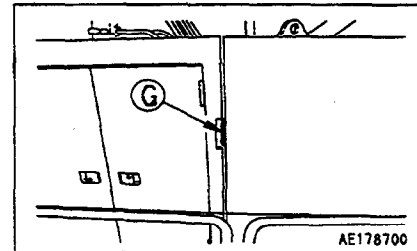
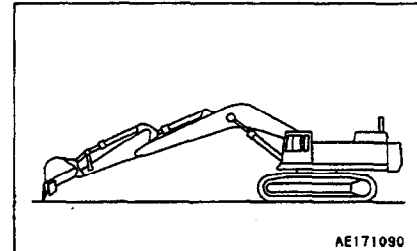

NOTICE

Do not add oil if the level is above the H line. This will damage the hydraulic equipment and cause the oil to spurt out.

4. If the level is below the L mark, remove the upper cover of the hydraulic tank and add oil through oil filler ⑦.

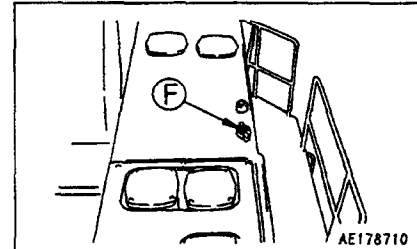

NOTICE

For details of the oil to use, see "20. USE OF FUEL, COOLANT AND LUBRICANTS ACCORDING TO AMBIENT TEMPERATURE".

REMARK

The oil level will vary depending upon the oil temperature. Accordingly, use the following as a guide:

- Before operation: around L level
(Oil temperature 10 to 30°C (50 to 86°F))
- Normal operation: around H level
(Oil temperature 50 to 80°C (122 to 176°F))

12.2 STARTING ENGINE

12.2.1 NORMAL STARTING

WARNING

Check that there are no persons or obstacles in the surrounding area, then sound the horn and start the engine.

NOTICE

Do not keep the starting motor rotating continuously for more than 20 seconds.

If the engine will not start, wait for at least 2 minutes before trying to start the engine again.

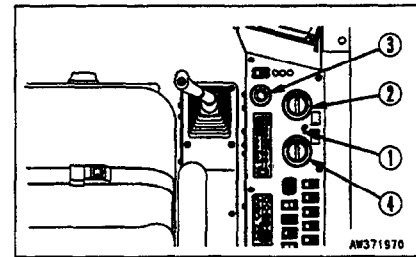

1. Turn the starter motor selector switch ① to FRONT engine.

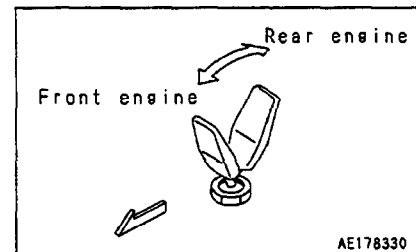

2. Set fuel control dial ② at the low idling (MIN) position.

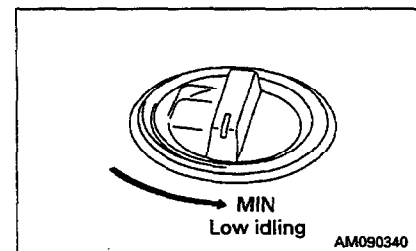

3. Turn the key in starting switch ③ to the START position. The engine will start.

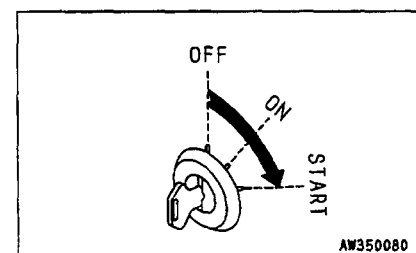

4. When the engine starts, release the key in starting switch ③. The key will return automatically to the ON position.

5. Turn the starter selector switch ① to REAR engine. Set fuel control dial ④ at the low idling (MIN) position, and repeat steps 3 - 4 to start the engine.

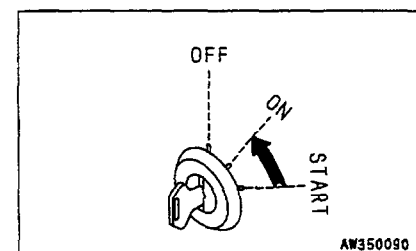

CLICK HERE TO **DOWNLOAD** THE COMPLETE MANUAL

- Thank you very much for reading the preview of the manual.
- You can download the complete manual from: www.heydownloads.com by clicking the link below



- Please note: If there is no response to CLICKING the link, please download this PDF first and then click on it.

CLICK HERE TO **DOWNLOAD** THE COMPLETE MANUAL

12. OPERATION

4. Operate right and left travel levers ⑤ or right and left travel pedals ⑥ as follows.

- **When the sprocket is at the rear of the machine**
Push levers ⑤ forward slowly or depress the front part of pedals ⑥ slowly to move the machine off.
- **When the sprocket is at the front of the machine**
Pull levers ⑤ backward slowly or depress the rear part of pedals ⑥ slowly to move the machine off.

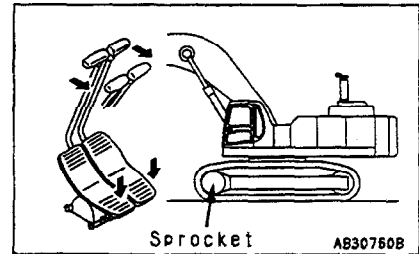
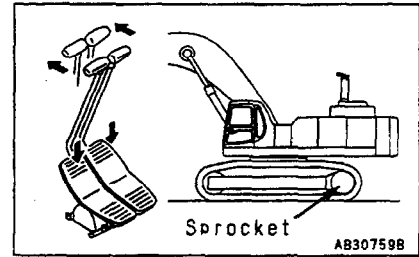

5. For machines equipped with the travel alarm (option), check that the alarm sounds.
If the alarm does not sound, please contact your Komatsu distributor for repairs.

12.4.2 MOVING MACHINE BACKWARD

WARNING

- Before operating the travel levers, check the direction of the track frame. If the sprocket is at the front, the operation of the travel levers is reversed.
- When moving off, check that the area around the machine is safe, and sound the horn before moving.
- Clear all personnel from the machine and the area.
- Clear all obstacles from the path of the machine.
- Use extreme care when reversing the machine. Note there is an blind spot behind the machine.
- If the lever is moved inside the deceleration range, engine speed will suddenly rise. Operate the levers carefully.
- For machines equipped with the travel alarm (option), check that the alarm works properly.

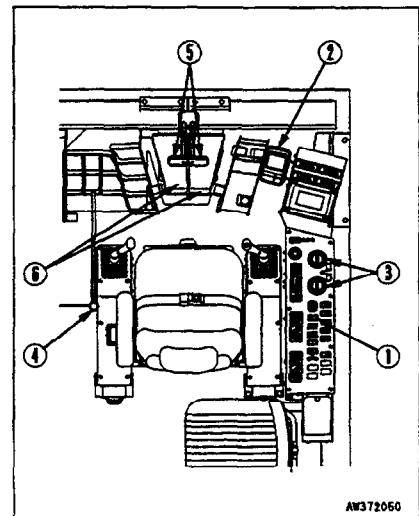

1. Set swing lock switch ① to the ON (actuated) position and confirm that swing lock monitor lamp ② lights up.

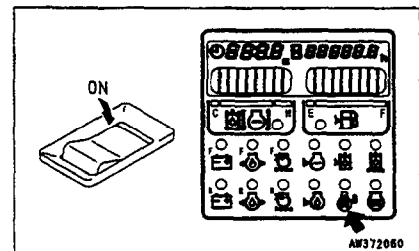

12.11 PRECAUTIONS FOR OPERATION

PRECAUTIONS WHEN TRAVELING

When traveling over obstacles such as boulders or tree stumps, the machine (in particular, the undercarriage) is subjected to a large shock, so reduce the travel speed and travel over the obstacle at the center of the tracks. As far as possible, remove such obstacles or avoid traveling over them.

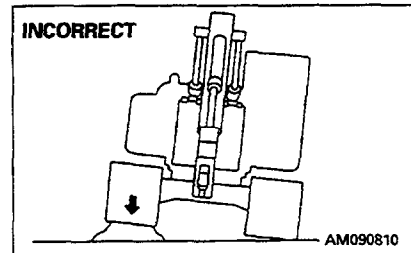

PERMISSIBLE WATER DEPTH NOTICE

When driving the machine out of water, if the angle of the machine exceeds 15°, the rear of the upper structure will go under water, and water will be thrown up by the radiator fan. This may cause the fan to break.

Be extremely careful when driving the machine out of water.

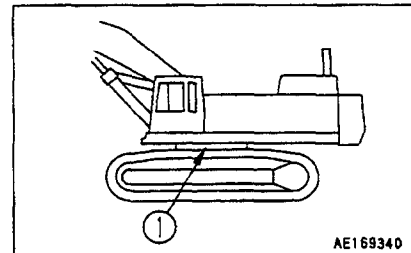

Do not immerse the machine in water by more than the permissible depth (under swing circle ①).

In addition, for parts that have been immersed in water for a long time, pump in grease until the old grease comes out from the bearings. (Around the bucket pins, and swing circle)

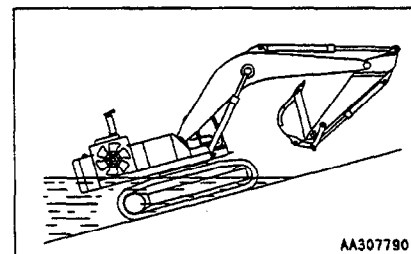

12.19 CHECK AFTER STOPPING ENGINE

1. Walk around the machine and check the work equipment, paintwork, and undercarriage, and check also for leakage of oil or water. If any abnormalities are found, repair them.
2. Fill the fuel tank.
3. Check the engine compartment for paper and debris. Clean out any paper and debris to avoid a fire hazard.
4. Remove any mud stuck to the undercarriage.

12.20 LOCKING

Always lock the following places.

- ① Door of operator's cab
Always remember to close the window.
- ② Fuel tank filler port
- ③ Battery box cover
- ④ Left side door of the machine (7 positions)
- ⑤ Right side door of the machine (2 positions)
- ⑥ Operator cab under box door
- ⑦ Engine hood (3 positions)
- ⑧ Box for storing emergency escape ladder

REMARK

Use the starting switch key to open and close all these places.

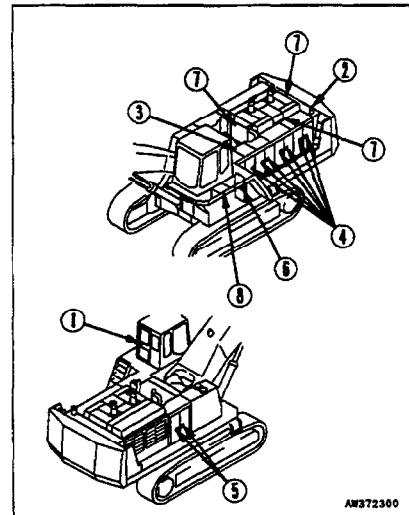

14. COLD WEATHER OPERATION

14.1 PRECAUTIONS FOR LOW TEMPERATURE

If the temperature is low, it becomes difficult to start the engine, and the coolant may freeze, so do as follows.

14.1.1 FUEL AND LUBRICANTS

Change to fuel and oil with low viscosity for all components. For details of the specified viscosity, see "20. USE OF FUEL, COOLANT AND LUBRICANTS ACCORDING TO AMBIENT TEMPERATURE".

14.1.2 COOLANT



WARNING

Keep antifreeze fluid away from an open flame. Never smoke when using antifreeze.

NOTICE

- Never use methanol, ethanol or propanol based antifreeze.
- Absolutely avoid using any water leak preventing agent irrespective of whether it is used independently or mixed with an antifreeze.
- Do not mix one antifreeze with a different brand.

For details of the antifreeze mixture when changing the coolant, see "24.3 WHEN REQUIRED".

Use a Permanent Antifreeze (ethylene glycol mixed with corrosion inhibitor, antifoam agent, etc.) meeting the standard requirements as shown below. With permanent antifreeze, no change of coolant is required for a year. If it is doubtful that an available antifreeze meets the standard requirements, ask the supplier of that antifreeze for information.

Standard requirements for permanent antifreeze

- SAE J1034
- FEDERAL STANDARD O-A-548D

REMARK

Where no permanent antifreeze is available, an ethylene glycol antifreeze without corrosion inhibitor may be used only for the cold season. In this case, clean the cooling system twice a year (in spring and autumn). When refilling the cooling system, add antifreeze in autumn, but do not add any in spring.

16. TROUBLESHOOTING

16.6.2 CHASSIS

- (): Always contact your Komatsu distributor when dealing with these items.
- In cases of abnormalities or causes which are not listed below, please contact your Komatsu distributor for repairs.

Problem	Main causes	Remedy
Speed of travel, swing, boom, arm, bucket is slow	<ul style="list-style-type: none"> ● Lack of hydraulic oil 	<ul style="list-style-type: none"> ● Add oil to specified level, see CHECK BEFORE STARTING
Pump generates abnormal noise	<ul style="list-style-type: none"> ● Clogged element in hydraulic tank strainer 	<ul style="list-style-type: none"> ● Clean, see EVERY 2000 HOURS SERVICE
Excessive rise in hydraulic oil temperature	<ul style="list-style-type: none"> ● Loose fan belt ● Dirty oil cooler ● Lack of hydraulic oil 	<ul style="list-style-type: none"> ● Adjust fan belt tension, see EVERY 250 HOURS SERVICE ● Clean, see EVERY 500 HOURS SERVICE ● Add oil to specified level, see CHECK BEFORE STARTING
Track comes off	<ul style="list-style-type: none"> ● Track too loose 	<ul style="list-style-type: none"> ● Adjust track tension, see WHEN REQUIRED
Abnormal wear of sprocket		
Bucket rises slowly, does not rise	<ul style="list-style-type: none"> ● Lack of hydraulic oil 	<ul style="list-style-type: none"> ● Add oil to specified level, see CHECK BEFORE STARTING

18.1.2 FUEL

- The fuel pump is a precision instrument, and if fuel containing water or dirt is used, it cannot work properly.
- Be extremely careful not to let impurities get in when storing or adding fuel.
- Always use the fuel specified in the Operation and Maintenance Manual.
Fuel may congeal depending on the temperature when it is used (particularly in low temperature below -15°C (5°F)), so it is necessary to change to a fuel that matches the temperature.
- To prevent the moisture in the air from condensing and forming water inside the fuel tank, always fill the fuel tank after completing the day's work.
- Before starting the engine, or when 10 minutes have passed after adding fuel, drain the sediment and water from the fuel tank.
- If the engine runs out of fuel, or if the filters have been replaced, it is necessary to bleed the air from the circuit.

18.1.3 COOLANT

- River water contains large amounts of calcium and other impurities, so if it is used, scale will stick to the engine and radiator, and this will cause defective heat exchange and overheating.
Do not use water that is not suitable for drinking.
- When using anti-freeze, always observe the precautions given in the Operation and Maintenance Manual.
- Komatsu machines are supplied with Komatsu original anti-freeze in the coolant when the machine is shipped.
This anti-freeze is effective in preventing corrosion of the cooling system.
The anti-freeze can be used continuously for two years or 4000 hours. Therefore, it can be used as it is even in hot areas.
- Anti-freeze is inflammable, so be extremely careful not to expose it to flame or fire.
- The proportion of anti-freeze to water differs according to the ambient temperature.
For details of the mixing proportions, see 24.3.2 CLEAN INSIDE OF COOLING SYSTEM.
- If the engine overheats, wait for the engine to cool before adding coolant.
- If the coolant level is low, it will cause overheating and will also cause problems with corrosion from the air in the coolant.

BLEEDING AIR FROM IDLER CUSHION CIRCUIT

Before pumping grease into the grease cylinder, always bleed the air.

1. Loosen grease fitting ① of the greae cylinder one turn. (left and right, 2 places)
Grease fitting ① can be loosened until it contacts the stopper, but do not remove the stopper and loosen it any further.
2. Open stop valves ② and ③ on the inside of the accelerator fully.
3. Loosen air bleed plug ④ of the cushion cylinder approx. one turn. (left and right, 2 places)
4. Start the engine and run at idling for 2 to 3 minutes.
5. When no more cloudy white oil comes out from air bleed plug ④ of the cushion cylinder, close stop valve ③. Leave stop valve ② open.
6. Operate the right travel lever 2 or 3 times to the FORWARD and REVERSE position.
7. Check that oil comes out from air bleed plugs ④ (left and right, 2 places) and ⑤, then close stop valve ② and air bleed plugs ④ and ⑤.
8. Tighten grease fittings ① (left and right, 2 places).

REMARKS

- Always tighten grease fitting ① last.
This completes bleeding of the air and pumping in of pressure oil.
- Check that all the stop valves and air bleed plugs are closed.
- Check that protrusion ① of the cushion cylinder plunger is 135 ± 5 mm (5.3 ± 0.2 in).

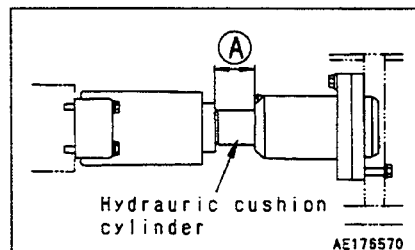
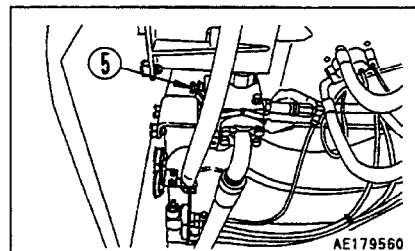
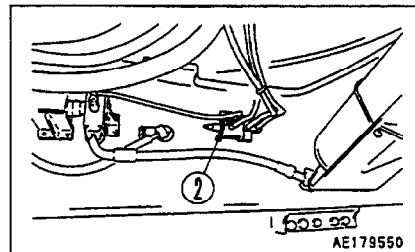
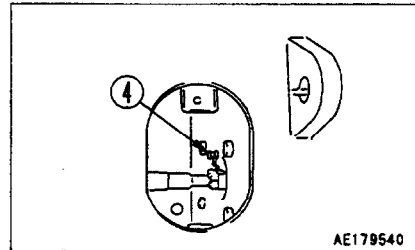
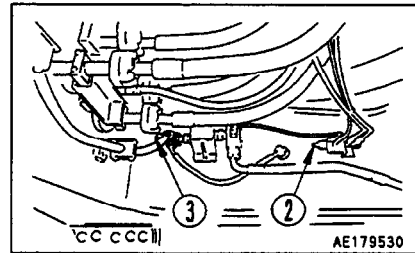
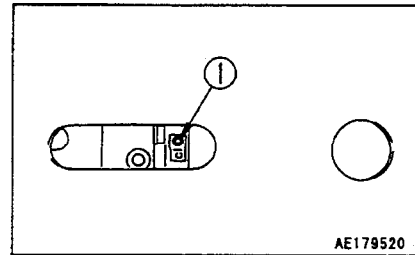

CRITICAL SAFETY PARTS

No.	Part name	Unit	Replacement intervals
①	Fuel hose (fuel tank – fuel strainer)	2	Every 4000 hours or every 2 years, whichever comes sooner
②	Fuel hose (fuel strainer – injection pump)	2	
③	Fuel hose (injection pump – fuel filter)	4	
④	Fuel return hose (fuel pump – adapter)	2	
⑤	Fuel return hose (adapter – fuel tank)	2	
⑥	Spill hose (between nozzles)	4	
⑦	Spill hose (nozzle – fuel tank)	2	
⑧	Turbocharger lubricating hose	2	
⑨	No.1 pump discharge port hose	2	
⑩	No.2 pump discharge port hose	2	
⑪	Swing No.1 pump discharge port hose	1	
⑫	Swing No.1 pump outlet branch hose	1	
⑬	No.3 pump discharge port hose	2	
⑭	No.4 pump discharge port hose	2	
⑮	Branch hose	4	
⑯	Swing No.2 pump discharge port hose	1	
⑰	Swing No.2 pump outlet branch hose	1	
⑱	Heater hose (engine – heater)	8	
⑲	Pump suction hose	8	
⑳	Swing line hose	4	
㉑	Boom cylinder line hose (B/H)	6	
㉒	Arm cylinder line hose (B/H)	8	
㉓	Bucket cylinder line hose (B/H)	8	
㉔	Bucket suction coupling	3	
㉕	Seat belt (option)	1	Every 3 years

- Prepare a container to catch drained coolant: Min. 85 ℓ capacity
 - Refill capacity: Each 85 ℓ (22.5 US gal) capacity.
1. Stop the engine, close valves ① on corrosion resistor.

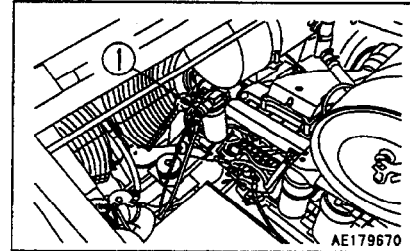

2. Turn cap ② slowly until it comes off.

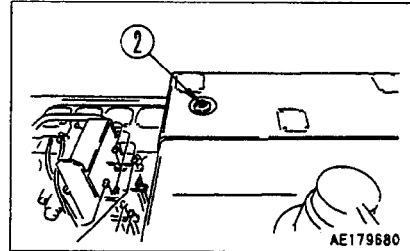

3. Loosen drain valve ③ and ④ at the bottom of engine and drain off the cooling water.

4. Close up drain valves ③ and ④ and pour in clean water (ex. city water) up to the vicinity of the water filler.

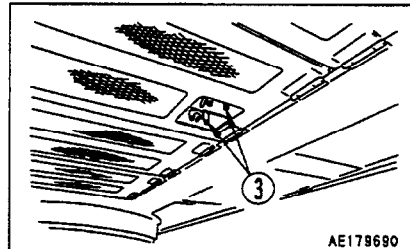

5. When the water reaches the vicinity of the water filler, put the engine at low idling, open drain valves ③ and ④, then pass water through the cooling system for 10 minutes. When doing this, keep the radiator filled up to the filler with water.

6. After washing the cooling system, stop the engine. Open drain valves ③ and ④ to drain water and close drain valves ③ and ④.

7. After draining off the cooling water, wash out the cooling system using commercially available detergent. Follow the instructions on the detergent container.

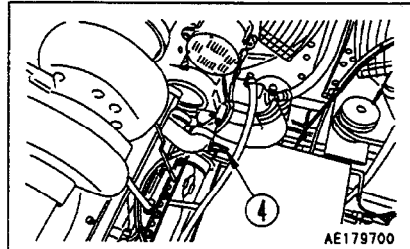

8. After washing the cooling system, drain off all the water, then close up drain valves ③ and ④ and pour in clean water (ex. city water) slowly up to the vicinity of the water filler.

9. When the water reaches the vicinity of the water filler, put the engine at low idling, open drain valves ③ and ④, then pass water through the cooling system until clean water comes out from the drain valves.

When doing this, keep the radiator filled up to the filler with water.

24.3.10 CLEANING, REMOVING DIRT FROM LINE FILTER

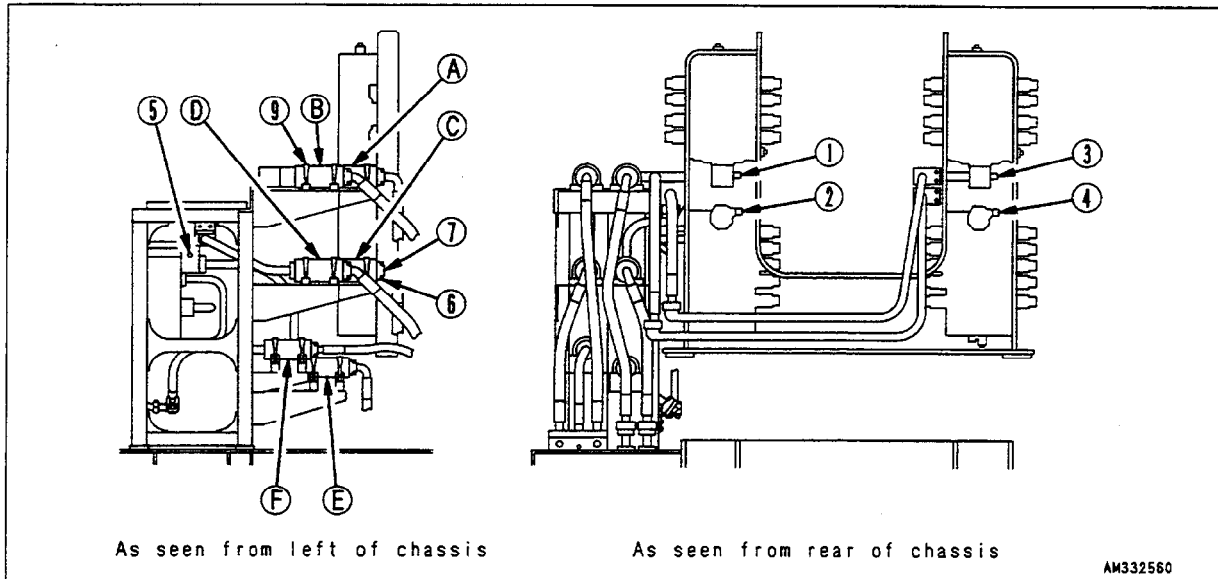

If there is any abnormality in the pumps or other hydraulic equipment, do as follows, and remove the dirt from inside the line filter.

1. Loosen the air suction plug (① - ⑤) corresponding to the line filter to be removed 1 - 2 turns.

- Relationship of line filter and air suction plug

Line filter A	→	plug ④
Line filter B	→	plug ①
Line filter C	→	plug ③
Line filter D	→	plug ②
Line filter E	→	plug ⑤
Line filter F	→	plug ⑥

2. Remove 4 bolts ⑥, and flange ⑦, then temporarily insert 2 of bolts ⑥ into cover ⑧.
Temporarily insert bolts ⑥ on diagonally opposite sides.
3. Loosen clamp ⑨.
4. Remove cover ⑧, and clean filter ⑩.
 - (1) When cleaning the filter, also clean off the dirt and dust stuck to the side face of the case.
 - (2) When assembling the case again, replace O-ring ⑪ and backup ring ⑫ together.
 - (3) Tightening torque for cover: $108 \pm 10 \text{ Nm}$
($11 \pm 1 \text{ kgm}$, ($79 \pm 7 \text{ lbft}$))
 - (4) After assembling the line filter again, bleed the air from the system. (For details, see "18.5 BLEEDING AIR FROM CIRCUIT")

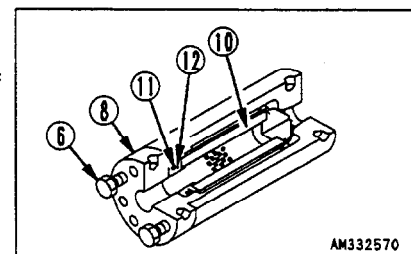

24.7.6 CHECK AIR CONDITIONER COMPRESSOR BELT TENSION, ADJUST (ONLY FOR MACHINES EQUIPPED WITH AIR CONDITIONER)

Checking

1. Remove bolts ② and ③, then remove cover ①.
2. The standard deflection for the drive belt is approx. 10 mm (0.4 in) when pressed with a thumb [at approx. 98.1 N (approx. 10 kgf)] at a point midway between the drive pulley and air conditioner compressor pulley.

Adjusting

1. Loosen bolts and nuts ④ – ⑧ in order, then turn nut ⑧ to move the compressor and adjust the belt tension.
Turn nut ⑧ as follows.
TIGHTEN to INCREASE belt tension
LOOSEN to DECREASE belt tension
2. After adjusting the belt tension, tighten the bolts and nuts in order from ⑦ to ④ to secure the compressor in position. Finally, tighten nut ⑧.
Check each pulley for damage, wear of the V-groove, and wear of the V-belt. Check in particular that the V-belt does not contact the bottom of the V-groove.
If the V-belt is elongated and there is no more allowance for adjustment, or if the belt is cracked or cut, replace the belt.
3. Install cover ①.

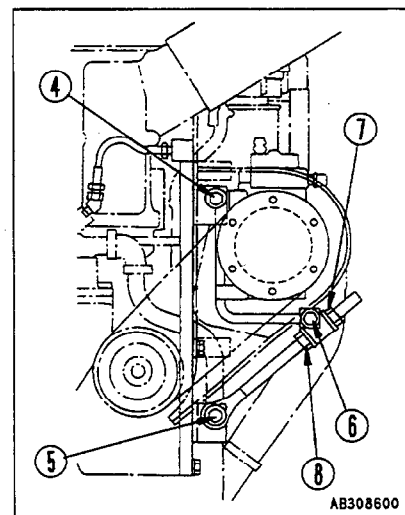
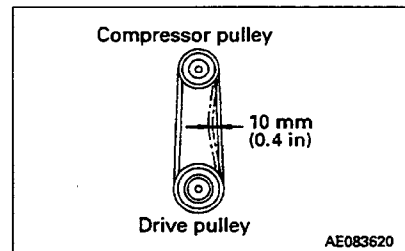
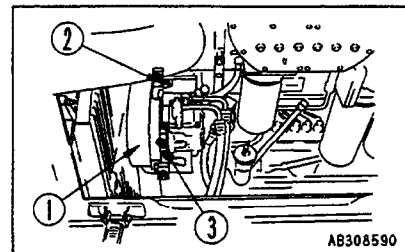

24.9.3 CHANGE OIL IN PTO CASE

⚠ WARNING

The oil is at high temperature immediately after the machine has been operated. Wait for the oil to cool down before carrying out maintenance.

NOTICE

Park the machine on flat ground and stop the engine. After waiting for more than 30 minutes after stopping the engine, check the oil level.

Prepare the following.

- Contain to catch drain oil: Min. 40 ℓ capacity
- Refill capacity: 20 ℓ each (10.6 US gal)

1. Drain oil from drain plug **(P)** at the bottom of the PTO case. After draining, tighten drain plug **(P)**.
2. Pour in the specified amount of engine oil through oil filler **(F)**.

NOTICE

For details of the oil to use, see "20. USE OF FUEL, COOLANT AND LUBRICANTS ACCORDING TO AMBIENT TEMPERATURE".

24.9.4 REPLACE CORROSION RESISTOR CARTRIDGE

1. Screw in valve **(2)** (2 pieces) at the top of the corrosion resistor **(1)**.
2. Using a filter wrench, turn cartridge to the left to remove it.
3. Coat the seal surface of the new filter cartridge with engine oil, then install it.
When installing, bring the packing surface into contact with the seal surface of the filter holder, then tighten a further 2/3 turn. Always use a genuine Komatsu cartridge.
4. Open valve **(2)**.
5. Run the engine and check that there is no leakage of water from the seal surface.

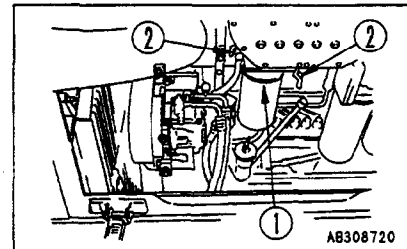
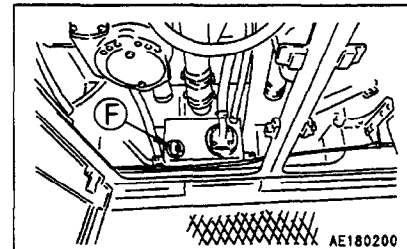
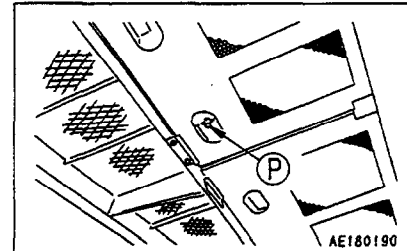

24.9.5 CHECK INSPECTION OF WELDING STRUCTURE (COLOR CHECK)

When the service meter over 4000 hours, check every 1000 hours.

CLICK HERE TO **DOWNLOAD** THE COMPLETE MANUAL

- Thank you very much for reading the preview of the manual.
- You can download the complete manual from: www.heydownloads.com by clicking the link below



- Please note: If there is no response to CLICKING the link, please download this PDF first and then click on it.

CLICK HERE TO **DOWNLOAD** THE COMPLETE MANUAL