

Operation & Maintenance Manual

HYDRAULIC
EXCAVATOR

PC09-1

SERIAL NUMBERS 12001 and up

⚠ WARNING

Unsafe use of this machine may cause serious injury or death. Operators and maintenance personnel must read this manual before operating or maintaining this machine. This manual should be kept near the machine for reference and periodically reviewed by all personnel who will come into contact with it.

NOTICE

Komatsu has Operation & Maintenance Manuals written in some other languages. If a foreign language manual is necessary, contact your local distributor for availability.

KOMATSU

CLICK HERE TO **DOWNLOAD** THE COMPLETE MANUAL

- Thank you very much for reading the preview of the manual.
- You can download the complete manual from: www.heydownloads.com by clicking the link below



- Please note: If there is no response to CLICKING the link, please download this PDF first and then click on it.

CLICK HERE TO **DOWNLOAD** THE COMPLETE MANUAL

YOUR MACHINE SERIAL NUMBERS AND DISTRIBUTOR

Machine serial No.	
Engine serial No.	
Product identification number (PIN)	
Distributor name Address Service Personnel Phone/Fax	----- ----- ----- -----

(4) Precautions for operating pattern (21S-98-32210)

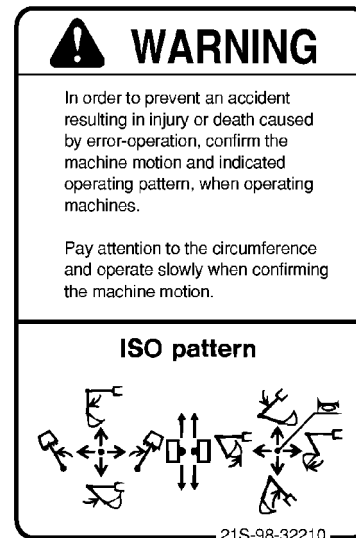

(5) Precautions for high-temperature Cooling water (20M-98-83250)

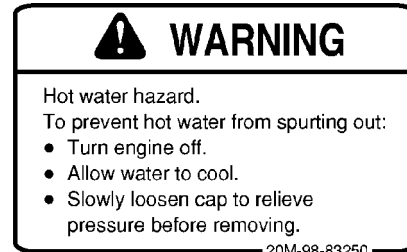

Hydraulic oil (21S-98-32160)

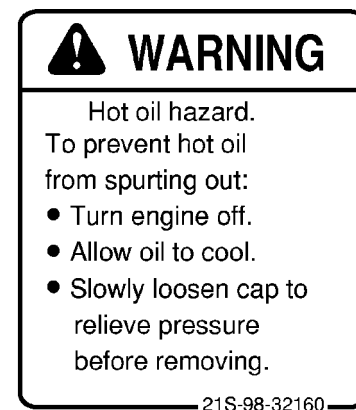

(6) Precautions for handling electric wires (09808-03000)

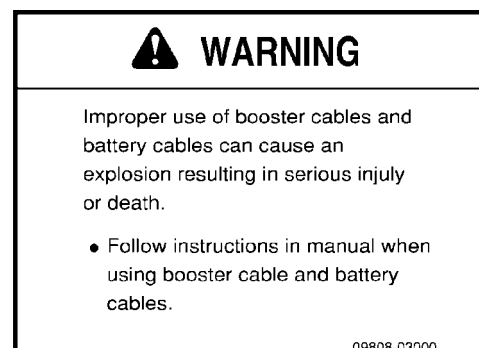

SAFETY MACHINE OPERATION

STARTING ENGINE

If there is a warning tag hanging from the work equipment control lever, do not start the engine or touch the levers.

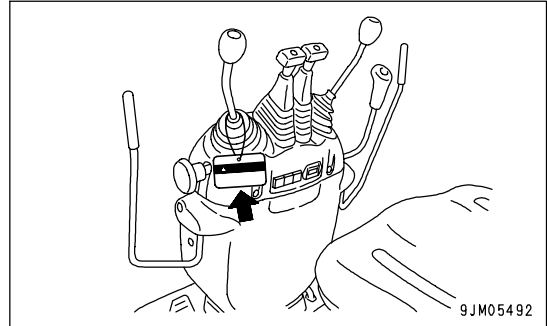

CHECKS BEFORE STARTING ENGINE

Carry out the following checks before starting the engine at the beginning of the day's work.

- Remove all dirt from the surface of the lens of the front lamps and working lamps, and check that they light up correctly.
- Check the coolant level, fuel level, and oil level in engine oil pan, check for clogging of the air cleaner, and check for damage to the electric wiring.
- Check that the gauges work properly, check the angle of the lights and working lamps, and check that the control levers are all at the neutral position.
- Before starting the engine, check that the lock lever is at the LOCK position.
- Check that there are no persons or obstacles above, below, or in the area around the machine.

SAFETY RULES FOR STARTING ENGINE

- When starting the engine, sound the horn as a warning.
- Start and operate the machine only while seated.
- Do not allow anyone apart from the operator to ride on the machine.
- Do not short circuit the starting motor circuit to start the engine. Short circuit can cause fire.

STARTING ENGINE IN COLD WEATHER

- Carry out the warming-up operation thoroughly. If the machine is not thoroughly warmed up before the control levers are operated, the reaction of the machine will be slow, and this may lead to unexpected accidents.
- If the battery electrolyte is frozen, do not charge the battery or start the engine with a different power source. There is a hazard that this will ignite the battery.

Before charging or starting the engine with a different power source, melt the battery electrolyte and check for frost and leakage of battery electrolyte before starting.

STARTING ENGINE WITH BOOSTER CABLES

If any mistake is made in the method of connecting the booster cables, it may cause the battery to explode, so always do as follows.

- When starting with a booster cable, carry out the starting operation with two workers (one worker sitting in the operator's seat and the other working with the battery).
- When starting from another machine, do not allow the two machines to touch.
- When connecting the booster cables, turn the starting switch OFF position for both the normal machine and problem machine. There is a hazard that the machine will move when the power is connected.
- Be sure to connect the positive (+) cable first when installing the booster cables. Disconnect the negative (-) cable (ground side) first when removing them.
- When removing the booster cables, be careful not to let the booster cable clips touch each other or to let the clips touch the machine.
- Always wear safety glasses and rubber gloves when starting the engine with booster cables.
- When connecting a normal machine to a problem machine with booster cables, always use a normal machine with the same battery voltage as the problem machine.
- For details of the starting procedure when using booster cables, see "Starting Engine with Booster Cables (PAGE 3-76)" in the OPERATION section.

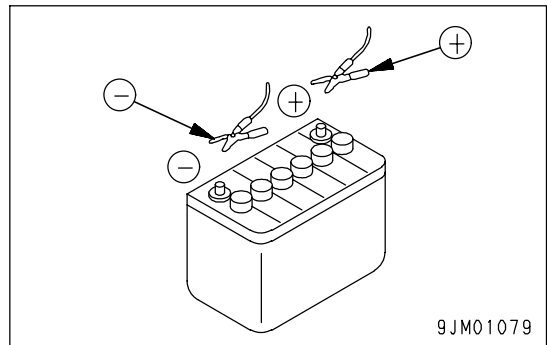
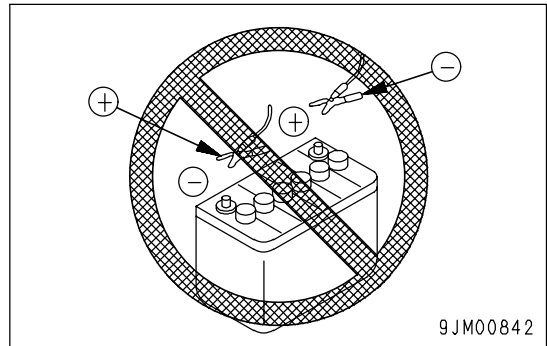

MACHINE VIEW ILLUSTRATIONS

OVERALL MACHINE VIEW

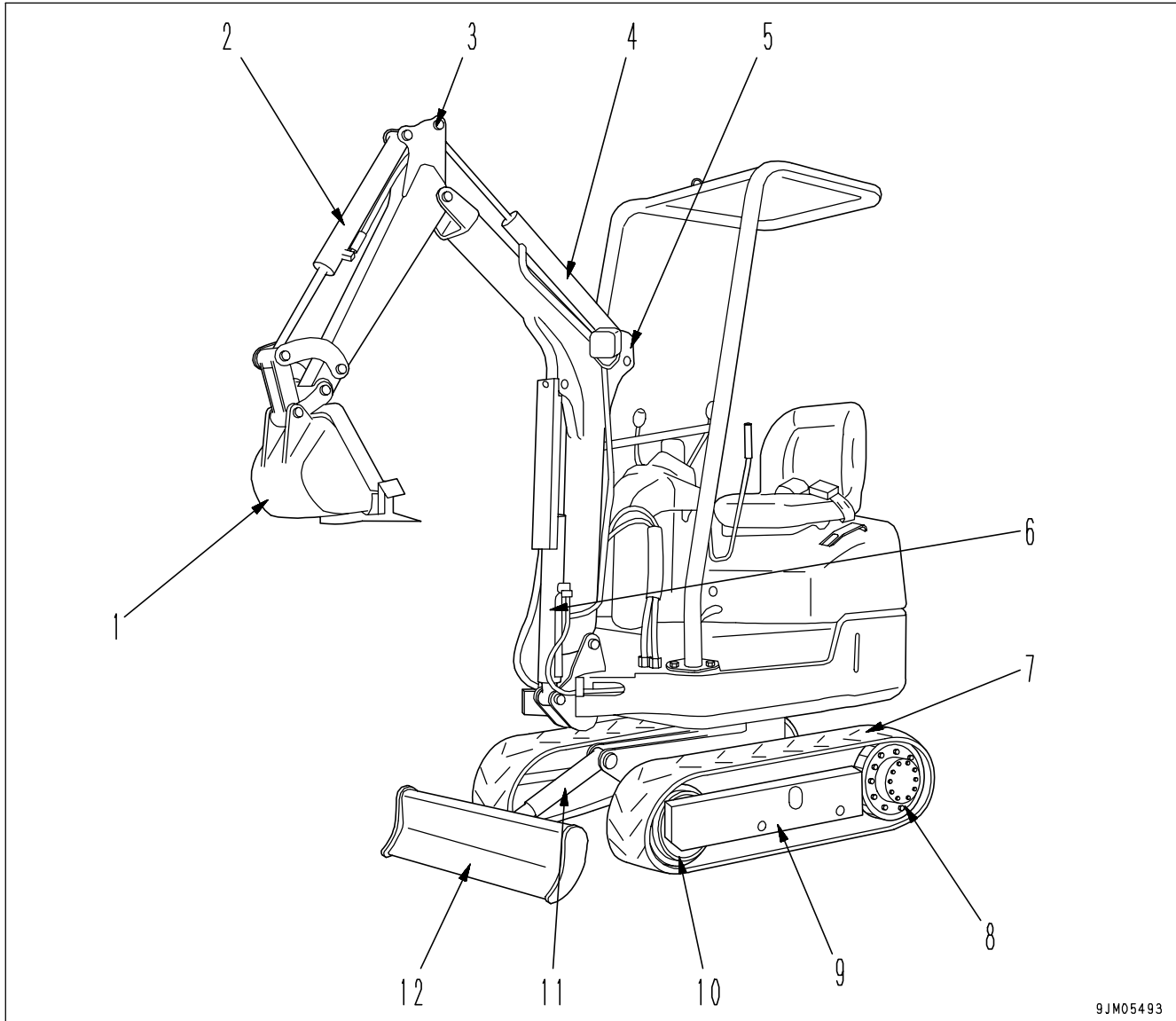

9JM05493

- (1) Bucket
- (2) Bucket cylinder
- (3) Arm
- (4) Arm cylinder
- (5) Boom
- (6) Boom cylinder

- (7) Track shoe
- (8) Sprocket
- (9) Track frame
- (10) Idler
- (11) Blade cylinder
- (12) Blade

Travel Levers



If the track frame is facing the rear, the direction of travel operations will be reversed.

When operating the travel levers, check if the track frame and blade are facing the front or the rear.

(If sprocket (A) is at the rear, the track frame is facing the front.)

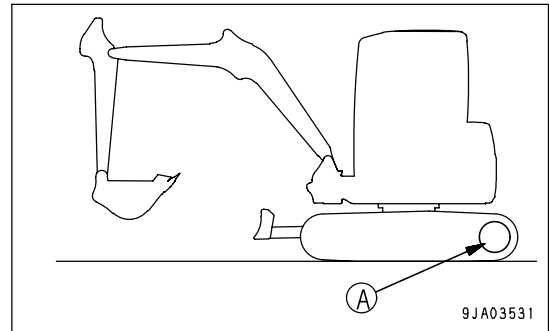

Use this lever (7) to driver the machine.

(a) FORWARD: The lever is pushed forward

(b) REVERSE: The lever is pulled back

N (Neutral): The machine stops

REMARK

When the travel lever is operated, the alarm buzzer sounds.

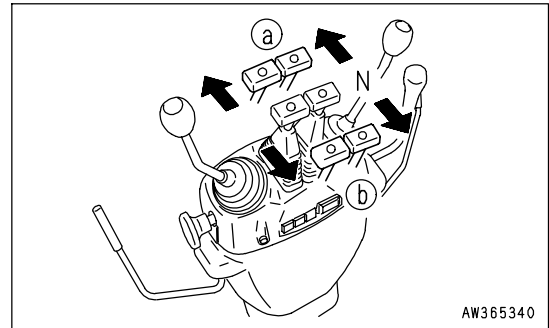

Pedal Lock

(For boom swing control pedal)



When the boom swing is not being used, lock the boom swing with the swing lock cover. If the control pedal is accidentally depressed when it is not locked, it may lead to a serious accident or injury.

This cover (8) is used to lock the boom swing control pedal.
The pedal is locked by fitting the cover over the pedal.

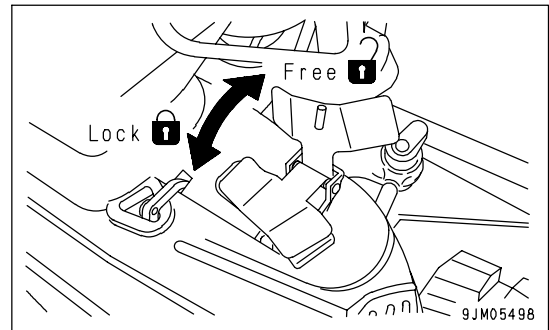

Boom Swing Control Pedal

This pedal (9) swings the boom to the left and right.

(a): Right swing

(b): Left swing

N (Neutral): Boom is stopped and held in this position.

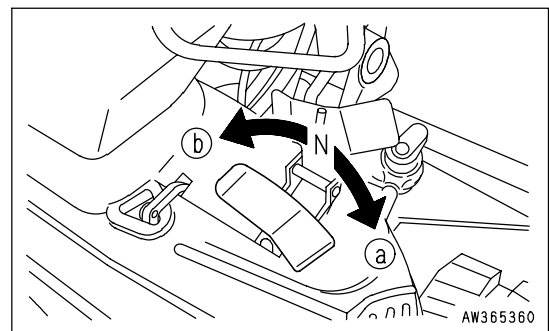

Check Oil Level in Hydraulic Tank, Add Oil



WARNING

When removing the oil filler cap, oil may spurt out, so turn the cap slowly to release the internal pressure before removing the cap.

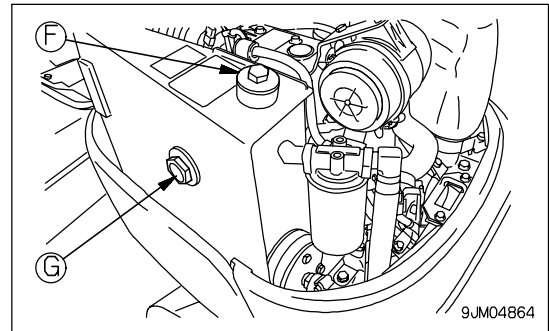

1. If the work equipment is not in the position shown in the diagram on the right, start the engine, run the engine at low speed, retract the arm and bucket cylinder rods fully, then lower the boom, set the bucket teeth in contact with the ground, and stop the engine.

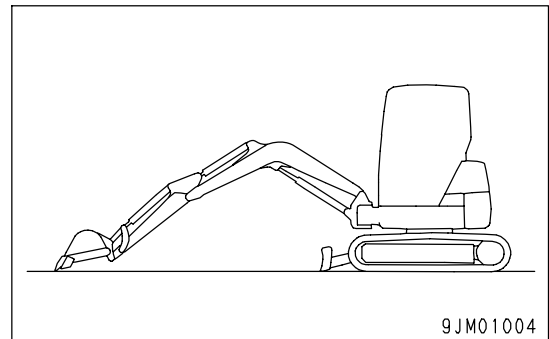

2. Confirm that the oil level is between the H and L marks of sight gauge (G).

NOTICE

Do not add oil if the level is above the H line. This will damage the hydraulic equipment and cause the oil to spurt out.

3. If the level is below that L mark, remove the upper cover of the hydraulic tank, add oil through oil filler (F).

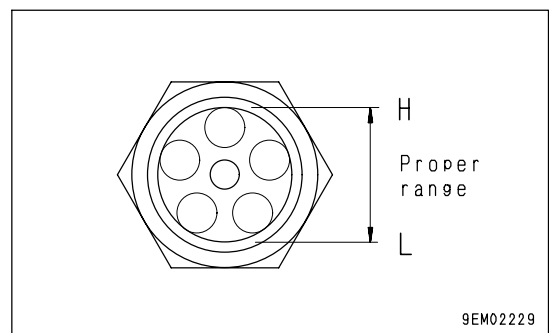

REMARK

The oil level will vary depending upon the oil temperature.

Accordingly, use the following as the guide:

- Before operation: around L level
(Oil temperature 10 to 30°C (50 to 86°F))
- Normal operation: around H level
(Oil temperature 50 to 80°C (122 to 176°F))

AFTER STARTING ENGINE



WARNING

- **Emergency stop**
If there has been any abnormal action or trouble, turn the starting switch key to the OFF position.
 - If the work equipment is operated without warming the machine up sufficiently, the response of the work equipment to the movement of the control lever will be slow, and the work equipment may not move as the operator desires, so always carry out the warming-up operation, particularly in cold areas, be sure to carry out the warming-up operation fully.
 - For operation patterns other than the standard one (ISO pattern), refer to the chapter of ATTACHMENTS AND OPTIONS in this manual.
-

Breaking-in the New Machine



CAUTION

Your Komatsu machine has been thoroughly adjusted and tested before shipment. However, operating the machine under severe conditions at the beginning can adversely affect the performance and shorten the machine life.

Be sure to break-in the machine for the initial 100 hours (as indicated by the service meter).

During break-in operations, follow the precautions described in this manual.

- Idle the engine for 5 minutes after starting it up.
- Avoid operation with heavy loads or at high speeds.
- Immediately after starting the engine, avoid sudden starts, sudden acceleration, unnecessary sudden stops, and sudden changes in direction.

SWINGING



WARNING

- The tail of the machine extends outside the tracks. Before operating the swing, check that the area around the machine is safe.
- If the swing control lever is operated quickly, the upper structure will swing quickly; and if it is operated slowly, the upper structure will swing slowly.

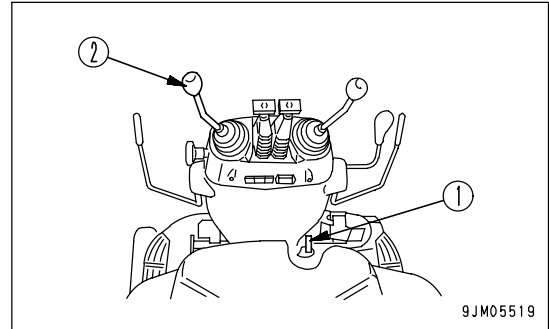

1. Before operating the swing, move swing lock lever (1) to the FREE position.

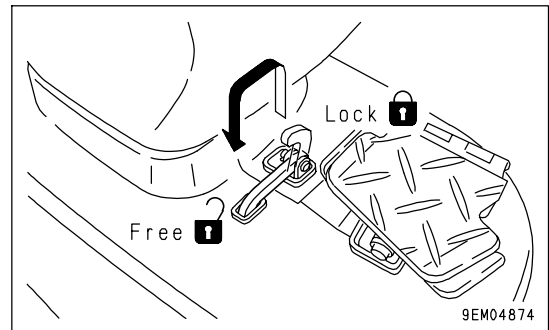

2. Operate left work equipment control lever (1) to swing the upper structure.

NOTICE

When using the swing on a slope, run the engine at low idling and operate the swing lever extremely slowly.

Be particularly careful to avoid sudden movement when the bucket is loaded.

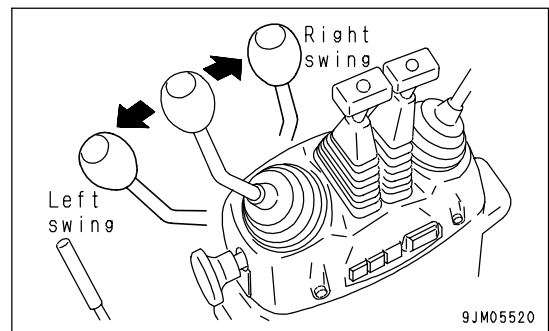

3. When not using the swing operation, set the upper structure parallel to the track frame, then set swing lock lever (1) to the LOCK position.

When setting to the LOCK position, always set the upper structure parallel to the track frame, then push the lever down fully. If the upper structure and track frames are not parallel, the lock will not be applied even if the lever is pushed to the LOCK position.

Do not operate the swing with the lock applied. The lock pin may break.

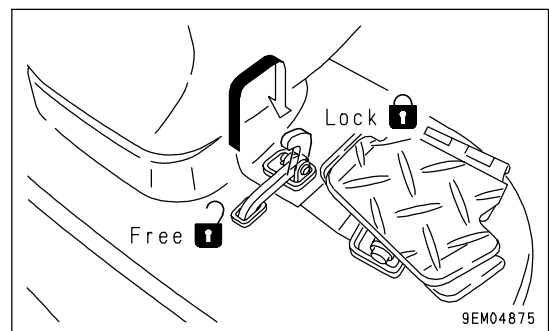

CLICK HERE TO **DOWNLOAD** THE COMPLETE MANUAL

- Thank you very much for reading the preview of the manual.
- You can download the complete manual from: www.heydownloads.com by clicking the link below



- Please note: If there is no response to CLICKING the link, please download this PDF first and then click on it.

CLICK HERE TO **DOWNLOAD** THE COMPLETE MANUAL

WORK POSSIBLE USING COMPACT HYDRAULIC EXCAVATOR

In addition to the following, it is possible to further increase the range of applications by using various attachments.

Backhoe Work

When condition of the machine is as shown in the diagram at right, each cylinder's maximum pushing excavation force is obtained when the bucket cylinder and link, arm cylinder and arm are at 90° .

When excavating, use this angle effectively to optimize your work efficiency.

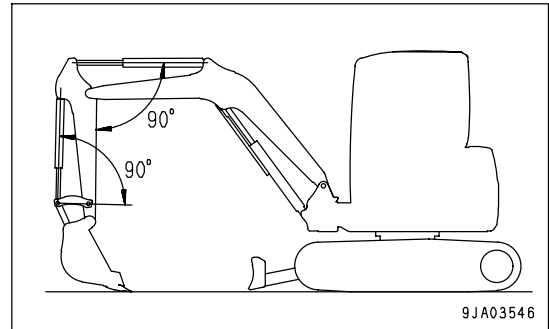

The range for excavating with the arm is from a 45° angle away from the machine to a 30° angle toward the machine.

There may be some differences depending on the digging depth, try to keep within the above range rather than operating to the end of the cylinder stroke.

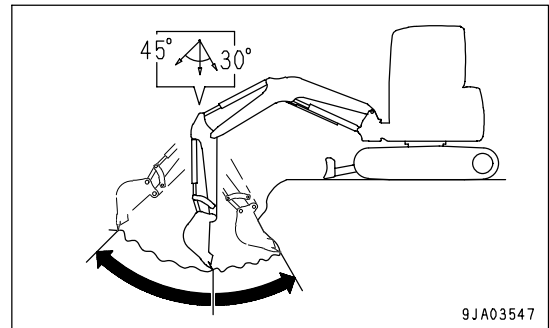

Ditching Work

Ditching work can be performed efficiently by attaching a bucket which matches the digging operation and then setting the tracks parallel to the line of the ditch to be excavated.

To excavate a wide ditch, first dig both sides and then finally remove the center portion.

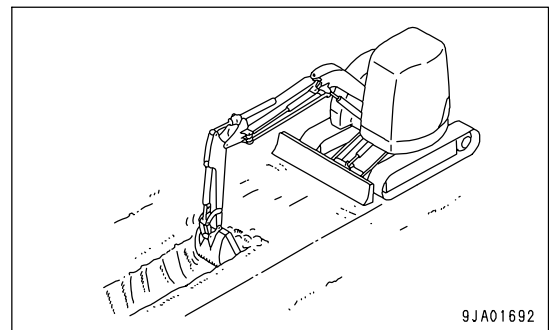

Loading Work

In places where the swing angle is small, work efficiency can be enhanced by locating the dump truck in a place easily visible to the operator.

Loading dump trucks is easier and the loading capacity is greater if the hydraulic excavator loads from the rear of the dump truck rather than from the side.

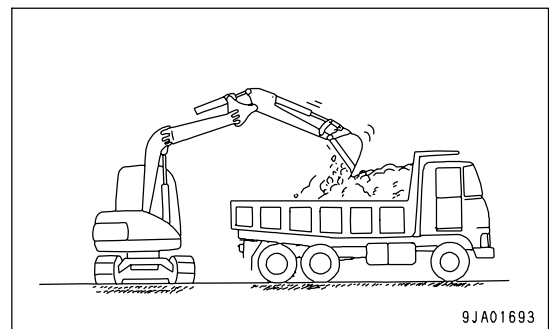

- If the machine is turned in this condition, the rubber shoe will come off.

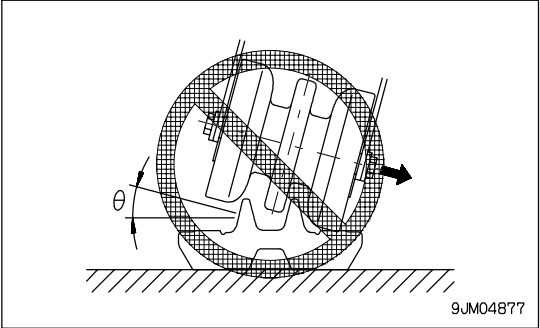

TROUBLES AND ACTIONS

RUNNING OUT OF FUEL

When starting the engine after running out of fuel, fill with fuel and bleed the air from the fuel system before starting. For details of bleeding the air, see "Air Bleeding (PAGE 4-43)".

PHENOMENA THAT ARE NOT FAILURES

Note that the following phenomena are not failures:

- When the arm is pulled in, the speed of movement will drop momentarily when the arm is more or less vertical.

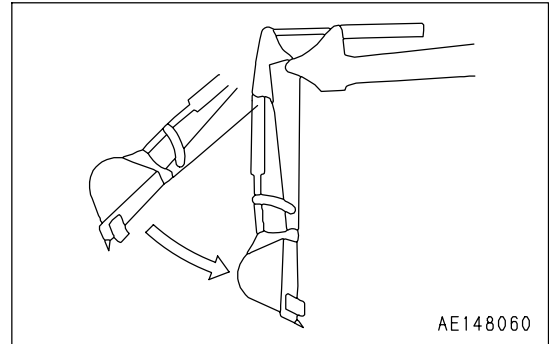

- The arm speed will drop momentarily when the bucket teeth are more or less horizontal.

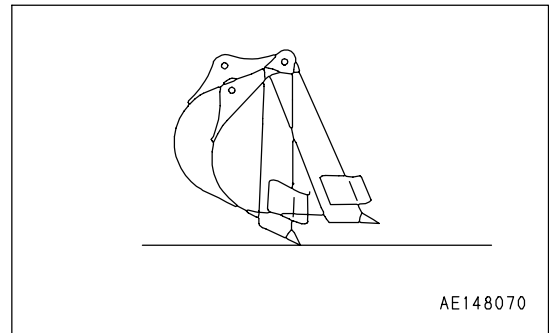

- When starting or stopping the swing, noise will be emitted from the brake valve.
- When going down a steep slope at low speed, a noise will be emitted from the travel motor.

REMARK

- When fuel sulphur content is less than 0.5%, change oil in the oil pan according to the periodic maintenance hours described in this manual.
Change oil according to the following table if fuel sulfur content is above 0.5%.
- When starting the engine with an atmospheric temperature of lower than 0°C (32°F), be sure to use engine oil of SAE10W, SAE10W-30 and SAE15W-40, even though the atmospheric temperature goes up to 10°C (50° F) more or less during the day.
- Use API classification CD as engine oil and if API classification CC, reduce the engine oil change interval to half.
- There is no problem if single grade oil is mixed with multigrade oil (SAE10W-30, 15W-40), but be sure to add single grade oil that matches the temperature range in the table.
- We recommend Komatsu genuine oil which has been specifically formulated and approved for use in engine and hydraulic work equipment applications.

Specified capacity: Total amount of oil including oil for components and oil in piping.

Refill capacity: Amount of oil needed to refill system during normal inspection and maintenance.

ASTM: American Society of Testing and Material

SAE: Society of Automotive Engineers

API: American Petroleum Institute

Fuel sulfur content	Engine oil change interval
0.5 to 1.0%	1/2 of regular interval
Above 1.0%	1/4 of regular interval

CLEAN INSIDE OF COOLING SYSTEM



WARNING

- Immediately after the engine is stopped, the coolant is at high temperature and the radiator under pressure. If the radiator cap is removed in this condition, boiling water may spurt out and cause burns. Wait for the temperature to go down, then turn the cap slowly to release the pressure.
- Start the engine and flush the system. When standing up from the operator's seat, or when leaving the operator's seat, always set the lock lever to the LOCK position.
- When starting the engine, see "BEFORE STARTING ENGINE (PAGE 3-18)" and "STARTING ENGINE (PAGE 3-29)" in the OPERATION section of the Operation and Maintenance Manual.
- Never enter the area at the rear of the machine when the engine is running.

Stop the machine on level ground when cleaning or changing the coolant.

Clean the inside of the cooling system, change the coolant according to the table below.

Coolant	Interval for cleaning inside of cooling system and changing antifreeze coolant
Komatsu genuine SUPERCOOLANT (AF-NAC)	Every two years or every 4000 hours whichever comes first

Komatsu genuine SUPERCOOLANT (AF-NAC) has the important function of preventing corrosion as well as preventing freezing. Even in the areas where freezing is not an issue, the use of antifreeze COOLANT is essential. Komatsu machines are supplied with SUPERCOOLANT (AF-NAC). SUPERCOOLANT (AF-NAC) has excellent anticorrosion, antifreeze and cooling properties and can be used continuously for two years or 4000 hours. As a basic rule, we do not recommend the use of any COOLANT other than SUPERCOOLANT (AF-NAC). If you use another COOLANT, it may cause serious problems, such as corrosion of the engine and aluminum parts of the cooling system.

To maintain the anticorrosion properties of COOLANT, always keep the density of COOLANT between 30% and 68%.

When selecting COOLANT, investigate the lowest temperature in the past and decide the density for the COOLANT from the COOLANT density table below. When actually deciding the density for the COOLANT, set it about 10°C (18°F) below lowest temperature. The density must be over 30% at least. If the density of obtained COOLANT is higher than the necessary density for lowest temperature, dilute it with adequate distilled water, and then fill it into the tank.

If there is any unclear point, please contact your Komatsu distributor.

Coolant density table

Minimum Temp	°C	Above -10	-15	-20	-25	-30	-35	-40	-45	-50
	°F	Above 14	5	-4	-13	-22	-31	-40	-49	-58
Concentration (%)		30	36	41	46	50	54	58	61	64

1. Loosen plug (1) gradually to release the grease.
2. When loosening plug (1), turn it a maximum of one turn.
3. If the grease does not come out smoothly, move the machine forwards and backwards a short distance.
4. Tighten plug (1).
5. To check if the tension is correct, run the engine at low idle, move the machine slowly forward (by an amount equal to the length of track on ground), then stop the machine.
6. Check the track tension again, and if the tension is not correct, adjust it again.

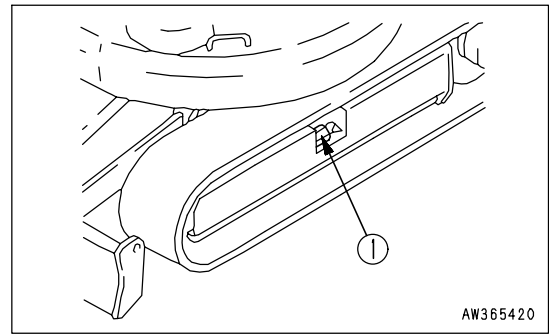

REPLACE RUBBER SHOES

WARNING

- Carry out this operation with two workers. The operator must move the machine in accordance with the signals from the other worker.
- The track tension is checked with the machine raised, so it is extremely dangerous if the machine comes down by mistake during the inspection. Stop the engine and set the lock lever to the LOCK position to prevent the machine from moving. Never put any part of your body under the track or track frame while measuring, and be extremely careful when taking the measurements.

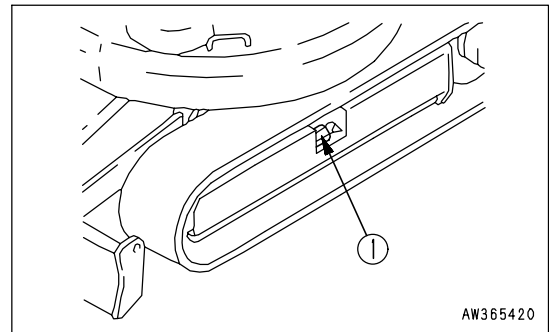

- Prepare a grease gun
- Prepare a steel pipe

Rubber Shoes Removal

WARNING

- It is extremely dangerous to release the grease by any method except the procedure given below. If the track tension is not relieved by this procedure, please contact your Komatsu distributor.
- Check that all the grease has been released before rotating the sprocket to remove the rubber shoe.

1. Raise the chassis with the boom and arm.
When doing this, operate the levers slowly.

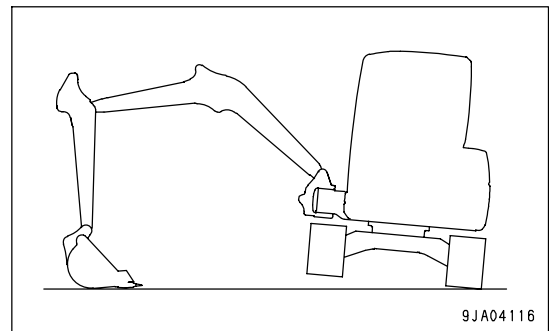

EVERY 500 HOURS MAINTENANCE

Maintenance for every 100 and 250 hours should be carried out at the same time.

LUBRICATING

(1) Boom cylinder foot pin (1 place)

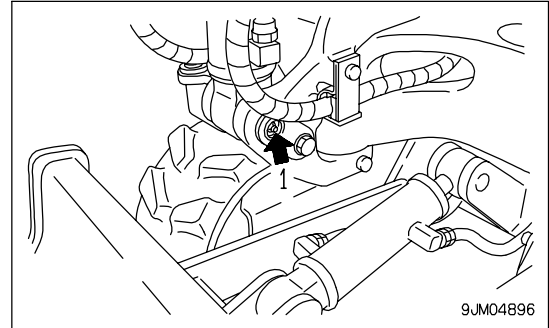

(2) Boom swing bracket pin (1 place)

(3) Boom foot pin (1 place)

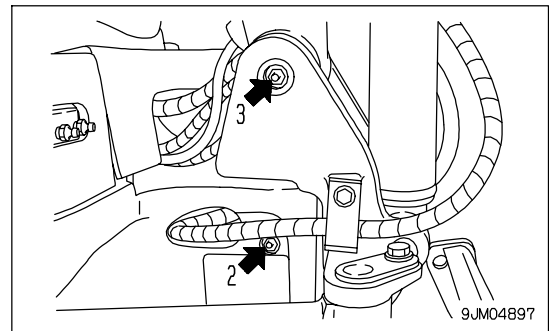

(4) Arm cylinder foot pin (1 place)

(5) Boom cylinder rod end (1 place)

(6) Arm cylinder rod end (1 place)

(7) Boom - Arm coupling pin (1 place)

(8) Bucket cylinder foot pin (1 place)

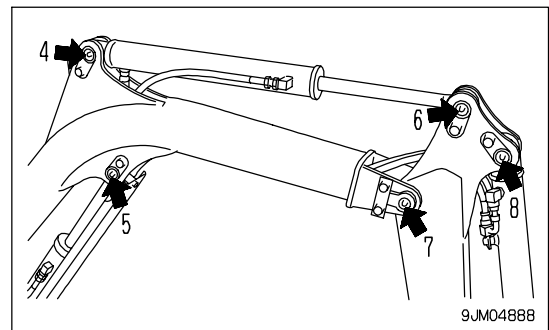

HANDLING ARM WITH BUILT-IN BREAKER

Using the arm with built-in-pin breaker, it is possible to carry out breaker operations without removing the bucket.

BUCKET POSTURE

Extend the bucket cylinder fully and pull in the bucket.

(For details, see "WORK EQUIPMENT CONTROLS AND OPERATIONS (PAGE 3-43)".

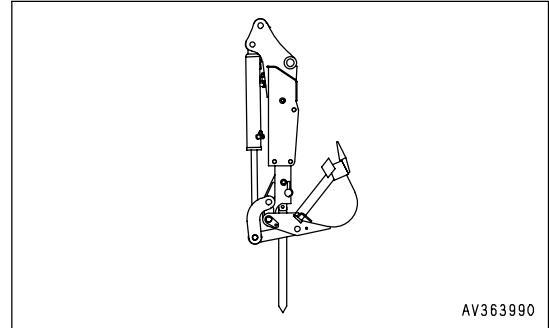

REMOVING AND INSTALLING CHISEL



WARNING

Always secure chisel lock lever (1) with lock plate (2). If the lock is not fitted securely, there is danger that the chisel may come out during breaker operations.

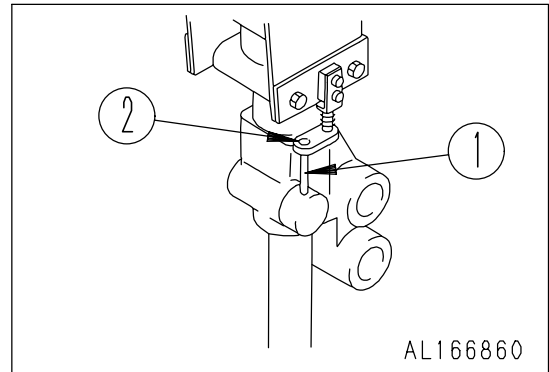

1. Turn the lock plate (2) 90° and insert chisel (3).

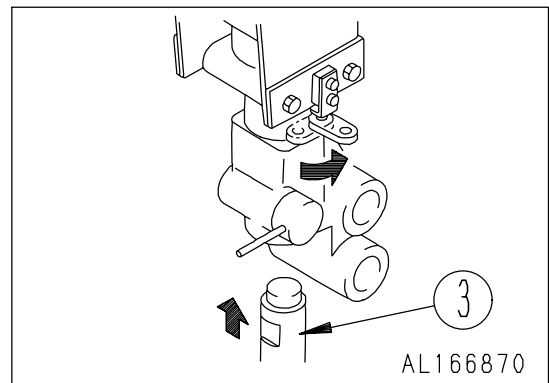

2. Set chisel lock lever (1) to the LOCK position.

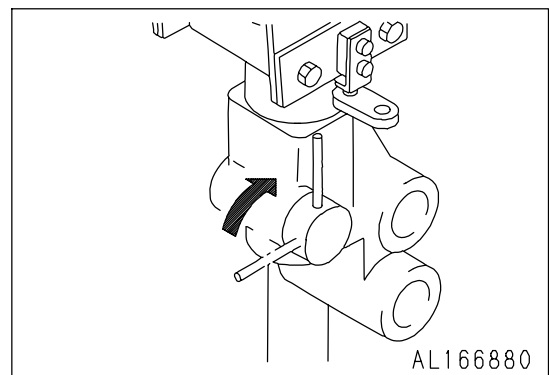

- 5. Insert bucket link pin (2).
- 6. Insert link pin (1), then push the ring in securely to lock in position.

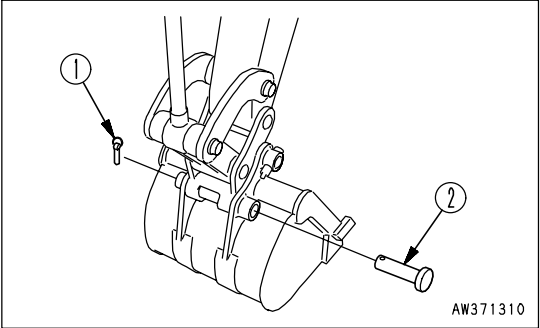

CLICK HERE TO **DOWNLOAD** THE COMPLETE MANUAL

- Thank you very much for reading the preview of the manual.
- You can download the complete manual from: www.heydownloads.com by clicking the link below



- Please note: If there is no response to CLICKING the link, please download this PDF first and then click on it.

CLICK HERE TO **DOWNLOAD** THE COMPLETE MANUAL