

Operation & Maintenance Manual

BULLDOZER

D85EX -15

D85PX -15

SERIAL NUMBERS

D85EX- 10250

D85PX- 1109

and up

NOTICE

Komatsu has Operation & Maintenance Manuals written in some other languages . If a foreign language manual is necessary , contact your local distributor for availability .

WARNING

Unsafe use of this machine may cause serious injury or Death. Operators and maintenance personnel must read this manual before operating or maintaining this machine. This manual should be kept near the machine for reference and periodically reviewed by all personnel who will come into contact with it .

KOMATSU

CLICK HERE TO **DOWNLOAD** THE COMPLETE MANUAL

- Thank you very much for reading the preview of the manual.
- You can download the complete manual from: www.heydownloads.com by clicking the link below



- Please note: If there is no response to CLICKING the link, please download this PDF first and then click on it.

CLICK HERE TO **DOWNLOAD** THE COMPLETE MANUAL

CONTENTS

FOREWORD	1- 1
FOREWORD	1- 2
SAFETY INFORMATION	1- 5
INTRODUCTION	1- 7
FRONT/REAR, LEFT/RIGHT DIRECTIONS OF MACHINE	1- 7
BREAKING IN THE MACHINE	1- 7
NECESSARY INFORMATION	1- 8
PRODUCT IDENTIFICATION NUMBER (PIN), MACHINE SERIAL NO. PLATE	1- 8
ENGINE SERIAL NO. PLATE	1- 8
POSITION OF SERVICE METER	1- 9
TABLE TO ENTER SERIAL NO. AND DISTRIBUTOR	1- 9
SAFETY	2- 1
SAFETY	2- 2
SAFETY LABELS	2- 4
POSITIONS OF SAFETY PICTOGRAMS	2- 4
SAFETY LABELS	2- 5
GENERAL PRECAUTIONS	2- 9
PRECAUTIONS FOR OPERATION	2- 17
BEFORE STARTING ENGINE	2- 17
OPERATION	2- 19
TRANSPORTATION	2- 23
BATTERY	2- 24
TOWING	2- 26
PRECAUTIONS FOR MAINTENANCE	2- 27
OPERATION	3- 1
GENERAL VIEW	3- 2
GENERAL VIEW OF MACHINE	3- 2
GENERAL VIEW OF CONTROLS AND GAUGES	3- 3
EXPLANATION OF COMPONENTS	3- 5
FRONT PANEL	3- 5
SWITCHES	3- 34
CONTROL LEVERS, PEDALS	3- 38
FUSE	3- 45
MAIN POWER CIRCUIT BREAKERS	3- 47
CIRCUIT BREAKER	3- 47
POWER SOURCE	3- 48
CAP WITH LOCK	3- 49
DOOR OPEN LOCK	3- 51
SASH GLASS INTERMEDIATE LOCK	3- 51
DOOR POCKET	3- 52
ASHTRAY	3- 52
TOOL BOX	3- 52
AIR CONDITIONER	3- 53
HEATER, HANDLING	3- 59
CAR STEREO, HANDLING	3- 60
EXTERNAL POWER SOURCE TYPE ENGINE PREHEATING HEATER	3- 68
OPERATION	3- 76
CHECK BEFORE STARTING ENGINE, ADJUST	3- 76
STARTING ENGINE	3- 95

(12) Roll-over precautions (09805-C0881)



Sign indicates a hazard of falling.

Do not stand in this place here.

(13) Jump start prohibited (09842-A0481)



Start the engine only after sitting down in the operator's seat.

Do not attempt to start the engine by short-circuiting the engine starting circuit. Such an act may cause a serious bodily injury or fire.

PRECAUTIONS WHEN STARTING

- Start and operate the machine only while seated.
- Do not attempt to start the engine by short-circuiting the engine starting circuit. Such an act may cause a serious bodily injury or fire.
- When starting the engine, sound the horn as a warning.
- Do not allow anyone apart from the operator to ride on the machine.

PRECAUTIONS IN COLD AREAS

- Carry out the warming-up operation thoroughly. If the machine is not thoroughly warmed up before the control levers are operated, the reaction of the machine will be slow, and this may lead to unexpected accidents.
- If the battery electrolyte is frozen, do not charge the battery or start the engine with a different power source. There is a hazard that this will ignite the battery and cause the battery to explode. Before charging or starting the engine with a different power source, melt the battery electrolyte and check that there is no leakage of electrolyte before starting.

STOP ENGINE BEFORE CARRYING OUT INSPECTION AND MAINTENANCE

- Stop the machine on firm, level ground.
- Select a place where there is no hazard of landslides, falling rocks, or flooding.
- Lower the work equipment completely to the ground and stop the engine.
- After stopping the engine, operate the work equipment control lever to the RAISE and LOWER positions 2 or 3 times to release the pressure remaining in the hydraulic circuit, then set the work equipment lock lever and Parking brake lever to LOCK position.

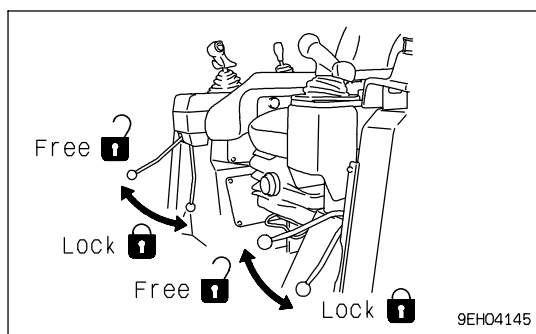
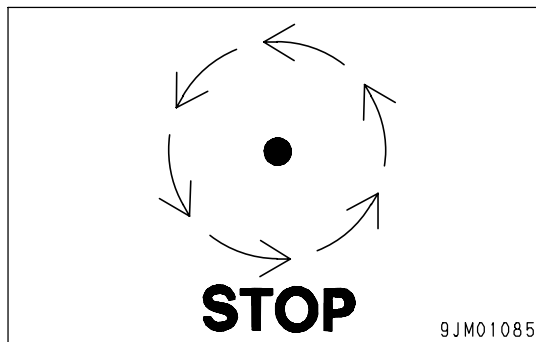

- Put blocks under the track to prevent the machine from moving.

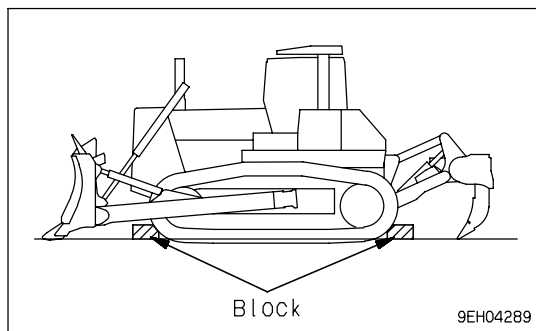

FRONT PANEL

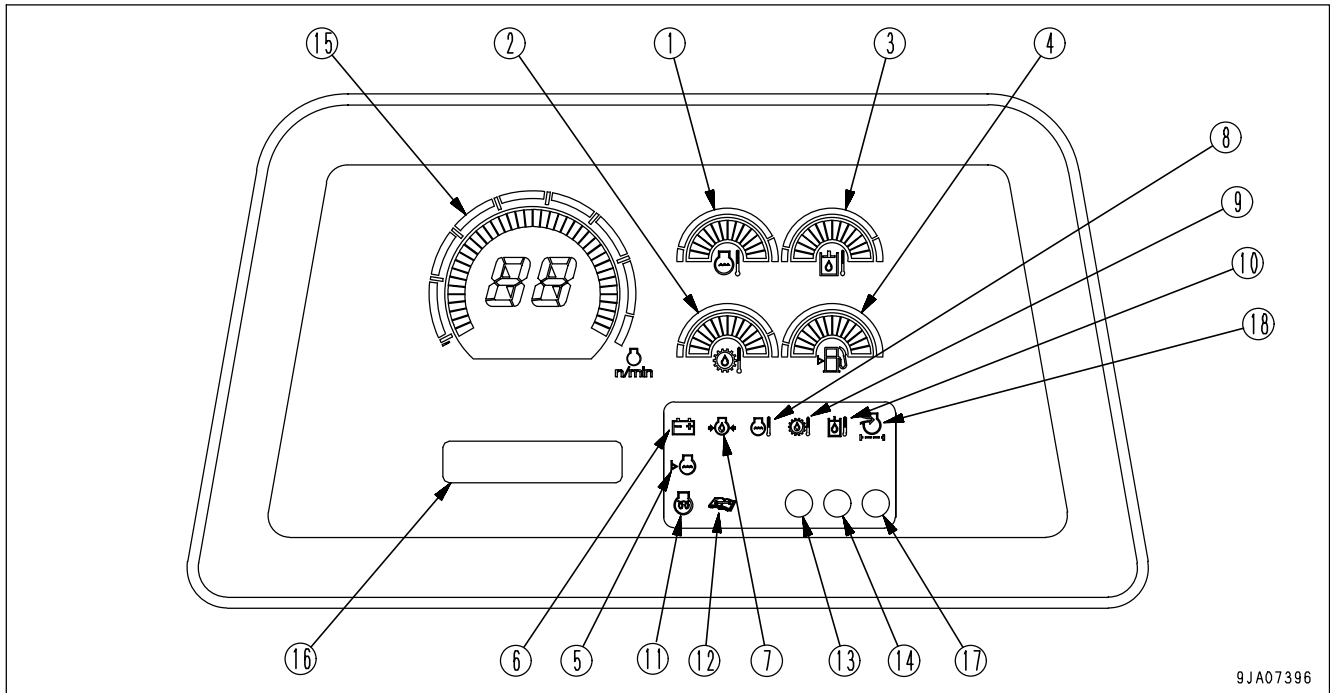

9JA07396

- | | |
|--|---|
| (1) Engine coolant temperature gauge | (11) Engine pre-heating pilot lamp |
| (2) Power train oil temperature gauge | (12) Maintenance caution lamp |
| (3) Hydraulic oil temperature gauge | (13) Warning lamp |
| (4) Fuel level gauge | (14) Filter / oil change interval lamp |
| (5) Radiator coolant level monitor | (15) Display panel A
(Speed range display, Engine speed) |
| (6) Charge level caution lamp | (16) Display panel B (Multi-information) |
| (7) Engine oil pressure caution lamp | (17) Fan operation confirmation lamp |
| (8) Engine coolant temperature caution lamp | (18) Air cleaner clogging caution lamp (If equipped) |
| (9) Power train oil temperature caution lamp | |
| (10) Hydraulic oil temperature caution lamp | |

ENGINE COOLANT TEMPERATURE GAUGE

NOTICE

If the coolant temperature gauge often enters red range (C), check the radiator for clogging.

Gauge (1) indicates temperature of the engine coolant.

If the temperature is normal during operation, green range (B) will light.

If red range (C) lights during operation, move the fuel control dial to lower engine speed to approx. 3/4 of the full speed, and run until the coolant temperature enters green range (B).

During operation, if red range (C) lights, engine coolant temperature monitor flashes and the alarm buzzer sounds, stop the machine and run at low idle until coolant temperature enters green range (B).

(A): White range

(B): Green range

(C): Red range

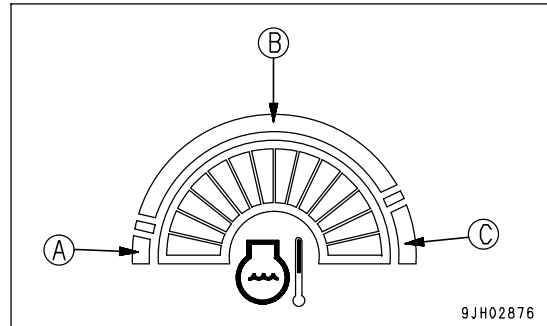

POWER TRAIN OIL TEMPERATURE GAUGE

NOTICE

If the power train oil temperature gauge often enters red range (C), shift down one speed range to reduce the load on the power train when operating.

Gauge (2) indicates the torque converter outlet oil temperature.

If the temperature is normal during operation, green range (B) will light.

If red range (C) lights up during operation, move the fuel control dial to lower engine speed to approx. 3/4 of the full speed, reduce the load and run until the oil temperature enters green range (B).

If red range (C) lights up, the power train oil temperature caution lamp flashes and the alarm buzzer sounds during operations, stop the machine, and run the engine at low idling until the oil temperature goes down to green range (B).

(A): White range

(B): Green range

(C): Red range

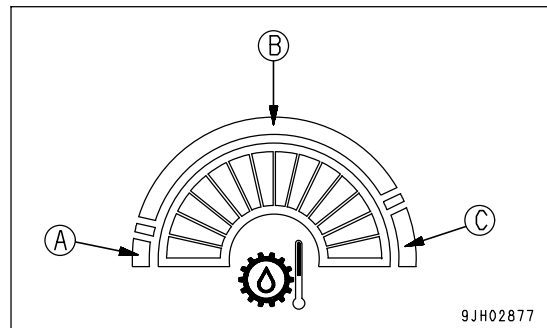

FILTER/OIL CHANGE INTERVAL LAMP

(Yellow)

This lamp (2) lights up when the time for replacing the filter or oil is near.

REMARK

This lamp (2) lights up if there is less than 30 hours remaining until replacement, and flashes when the replacement interval has passed.

At the same time, maintenance caution lamp (A) also lights up.

After replacing the indicated filter or oil displayed on display panel B (multi-information), reset the interval. For details, see "METHOD OF USING MAINTENANCE MODE (PAGE 3-27)".

The lamp goes out.

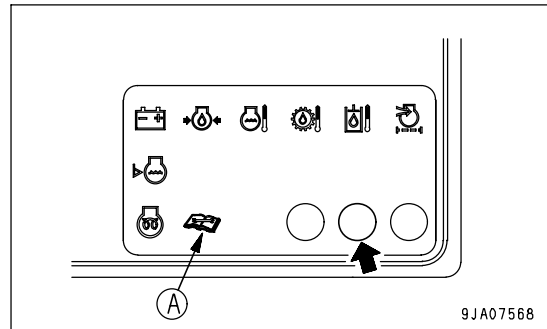
**FAN OPERATION CONFIRMATION LAMP**

(Orange)

If the fan rotation selector switch is operated when the engine is running, this lamp flashes to warn the operator that the fan operation cannot be switched.

- Before the engine starts, if the starting switch is turned to the ON position and the fan rotation selector switch is set to the reverse mode (REV) position or clean mode (CLN) position, lamp (3) lights up to inform the operator that the fan is set to reverse mode (REV) or clean mode (CLN). After the engine starts, the lamp goes out.

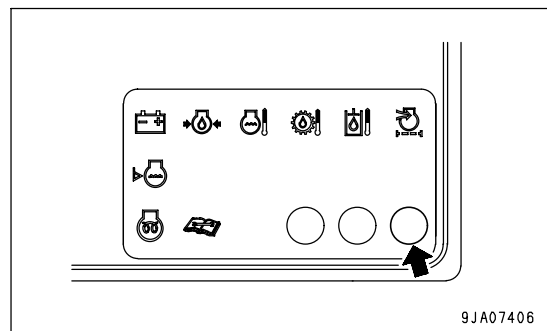

SWITCHES

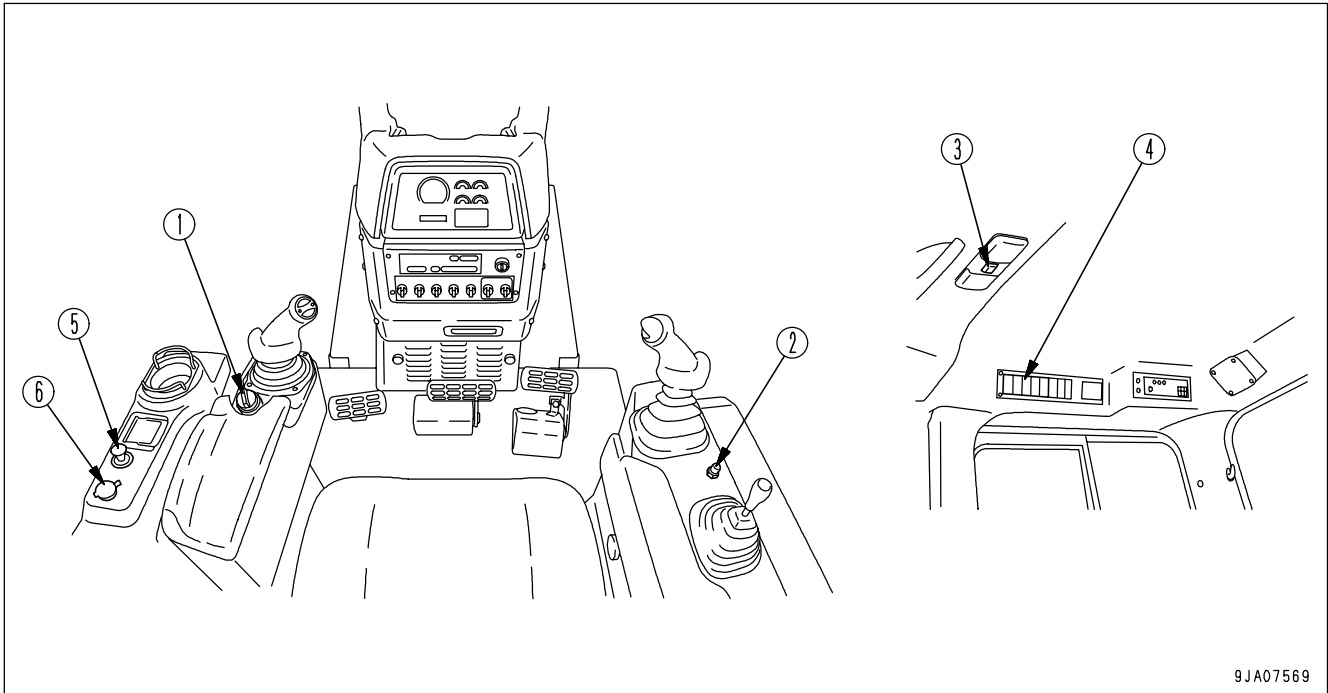

9JA07569

- (1) Fuel control dial
- (2) Horn switch
- (3) Room lamp switch
- (4) Wiper switch
- (5) Cigarette lighter
- (6) Accessory socket

FUEL CONTROL DIAL

Dial (1) is used to control the engine speed and output.

- (a) Low idling position: Turn fully to the left
- (b) High idling position: Turn fully to the right

REMARK

To stop the engine, turn the starting switch to the OFF position.

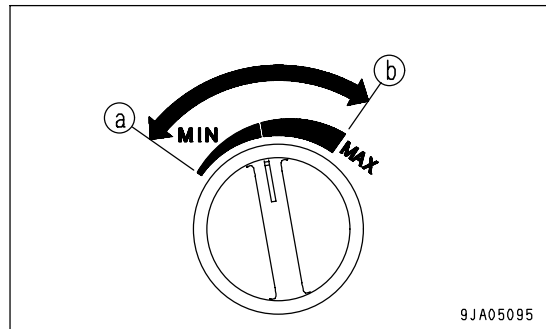

9JA05095

HORN SWITCH

The horn sounds when the button (2) at the rear of the blade control lever at the right side of the operator's seat is pressed.

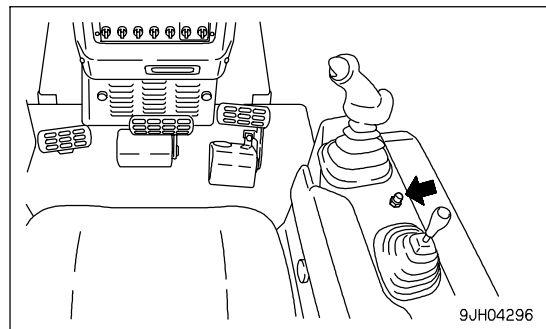

9JH04296

VARIABLE MULTI-SHANK RIPPER SPECIFICATION

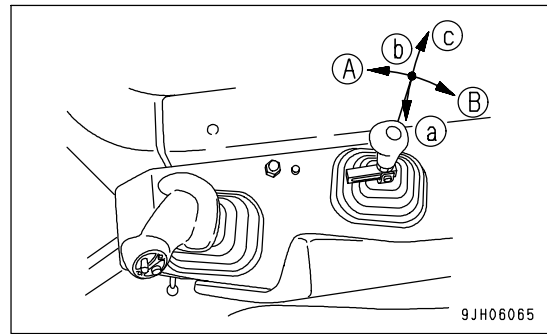

9JH06065

• Lift operation

- (a) RAISE
- (b) HOLD: Ripper is stopped and held in the same position.
- (c) LOWER

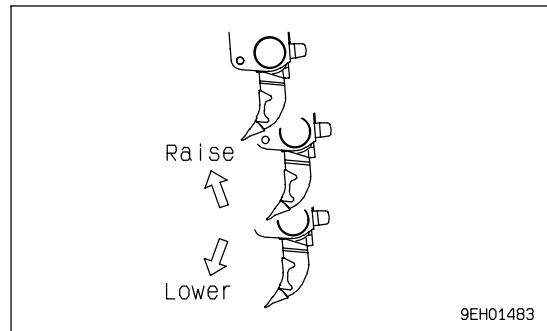

9EH01483

• Tilt operation

- (A) Tilt in
- (B) Tilt back

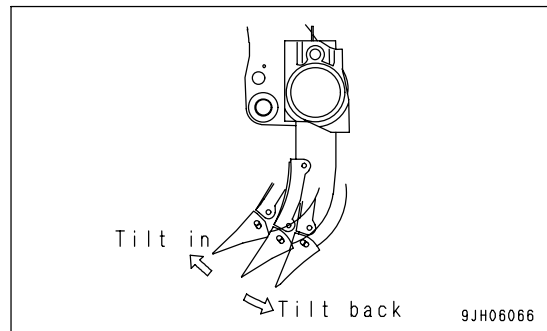

9JH06066

AIR CONDITIONER SWITCH

This switch (2) is used to start or stop the cooling or dehumidifying function.

When the fan switch is turned ON and the air conditioner switch is pressed, the indicator lamp above the switch lights up. When the switch is pressed again, the switch is turned OFF and the indicator lamp goes out.

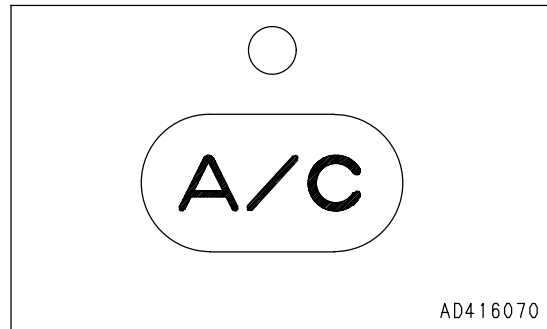
**FRESH/RECIRC SELECTOR SWITCH**

This switch (3) is used to select between recirculation of the air inside the cab or intake of fresh air from outside.

When the switch is pressed, indicator lamp (A) at the top of the switch lights up.

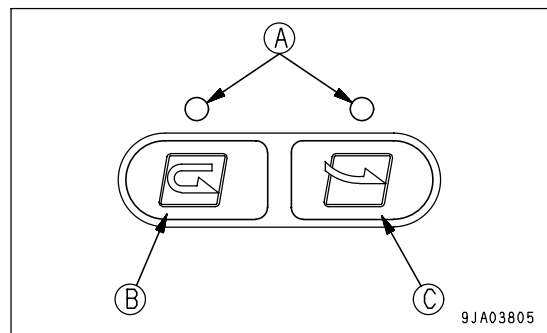
**Recirculation of air inside cab**

Press this switch (B) to use only the air inside the cab. Use this position to carry out rapid heating or cooling of the cab or when the outside air is dirty.

Intake of fresh air from outside

Press this switch (C) to carry out heating or cooling with fresh air taken in from the outside. Use this position when fresh air is taken in from outside the cab, or when removing the mist from the cab windows.

REMARK

When fresh air is taken into the cab, air pressure in the cab increases, which prevents the dust from entering. When neither heating nor cooling is needed, bring in clean fresh air, with your preferred air flow, to prevent dust from entering the cab.

METAL TAPE BUTTON

(used also for preset button No. 5)

This button (11) is used when playing a metal or chrome tape. This button is also used for preset button No. 5. When it is pressed, "MTL" appears on the display.

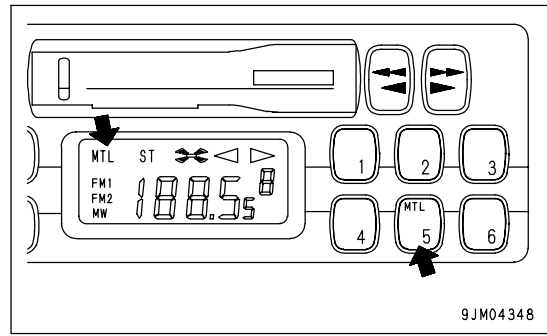

MANUAL TUNING BUTTONS

These buttons (12) are used for manual tuning.

When "TUN ^" button is pressed, the frequency goes up; when "TUN v" button is pressed, the frequency goes down. If the button is pressed down and held, the frequency will change continuously.

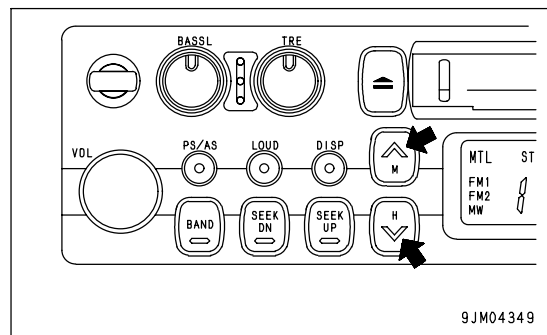

SEEK TUNING BUTTONS

These buttons (13) are used to seek tuning.

When the "SEEK UP" button is pressed, the search automatically goes up; when the "SEEK DN" button is pressed, the search automatically goes down.

When the next station that can be received is found, it automatically stops.

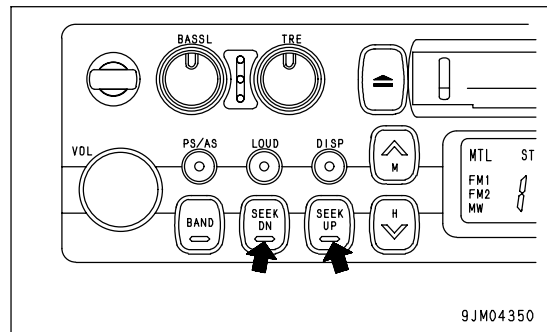

BAND SELECTOR BUTTON

When this button (14) is pressed, the band is switched between FM1, FM2, and MW (AM). The band is shown on the display.

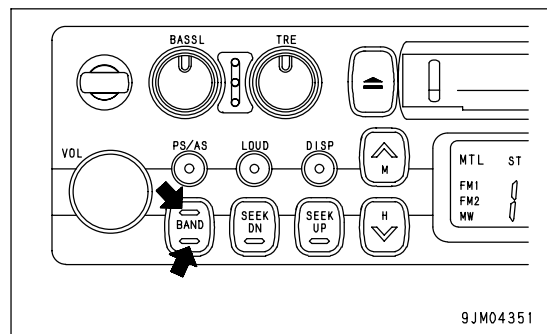

2. Turn the power for the engine preheating heater on several hours before starting the engine to warm up the coolant and oil in the engine oil pan.

1) Connect the power supply to the input socket on the machine with a cable.

The input socket on the machine is inside the battery cover on the left side of the machine.

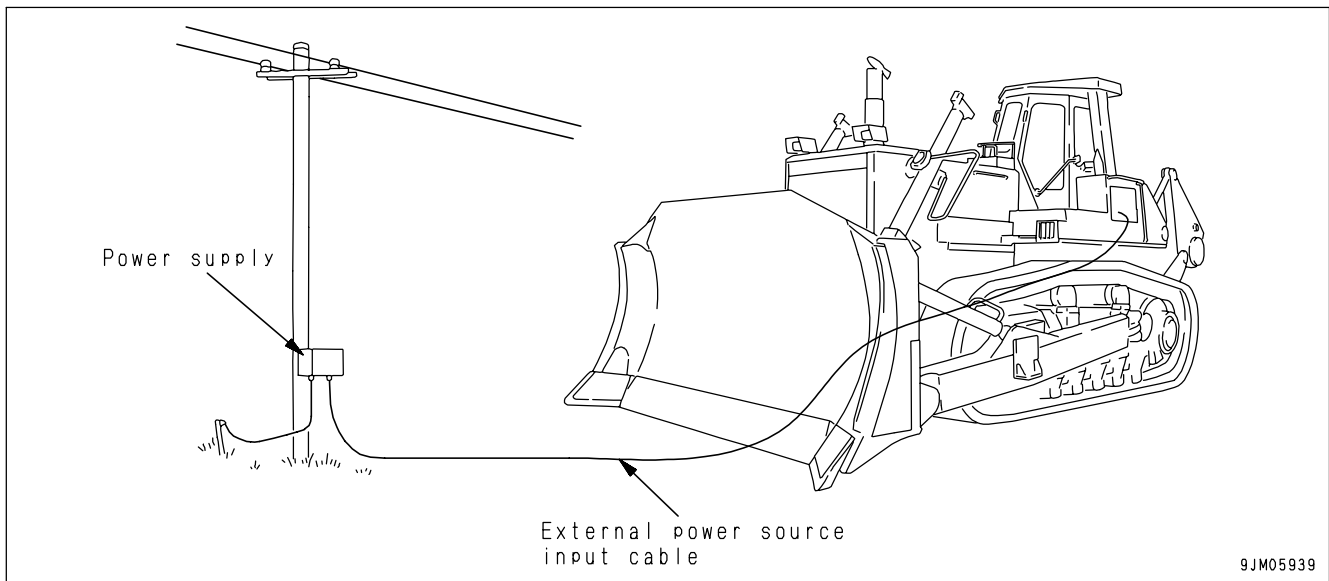
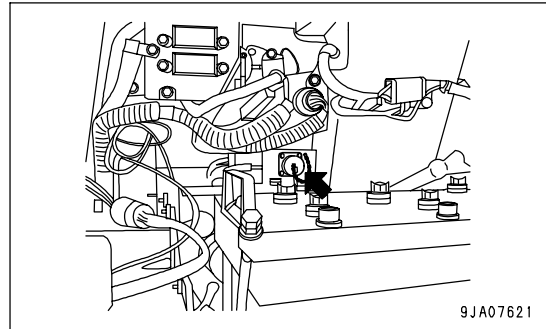

2) Use the standby switch (if available) or the power switch (main switch) on the power supply equipment to start the supply of electricity.

- Never connect the cables after the power switch has been turned ON. This is dangerous.
- Check that the grounding wiring is properly grounded before turning the power switch ON.

CHECK ELECTRIC WIRING



WARNING

- If fuses are frequently blown or if there is a short circuit in the electrical wiring, locate the cause and repair or contact your Komatsu distributor.
- Accumulation of flammable material (dead leaves, twigs, grass, etc.) around the battery may cause fire, so always check and remove such material.
- Keep the top surface of the battery clean and check the breather hole in the battery cap. If it is clogged with dirt or dust, wash the battery cap to clear the breather hole.

Check for damage and wrong capacity of the fuse and any sign of disconnection or short circuit in the electric wiring. Check also for loose terminals and tighten any loose parts.

Check the wiring of the "battery", "starting motor" and "alternator" carefully in particular.

Always check if there is any accumulation of flammable material around the battery, and remove such flammable material.

Please contact your Komatsu distributor for investigation and correction of the cause.

CHECK MACHINE MONITOR

1. Turn starting switch (1) to the ON position.
2. Check that the monitor and gauges light for 3 seconds, and the alarm buzzer sounds for 1 seconds.

REMARK

If the lamps do not light up, there may be a failure or disconnection in the monitor, please contact your Komatsu distributor.

NOTICE

Do not simply use the monitor to carry out the check before starting. Always carry out the check before starting according to the procedure on the following pages.

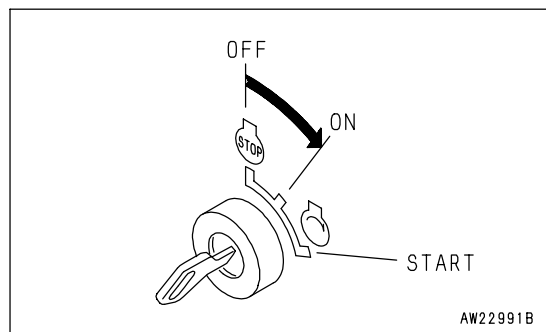
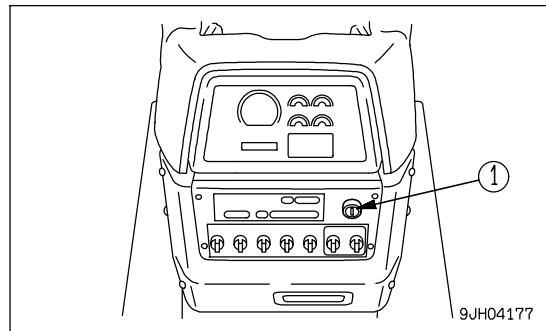

CLICK HERE TO **DOWNLOAD** THE COMPLETE MANUAL

- Thank you very much for reading the preview of the manual.
- You can download the complete manual from: www.heydownloads.com by clicking the link below



- Please note: If there is no response to CLICKING the link, please download this PDF first and then click on it.

CLICK HERE TO **DOWNLOAD** THE COMPLETE MANUAL

3. Check that the blade is lowered to the ground and that blade control lever (3) is in the HOLD position.

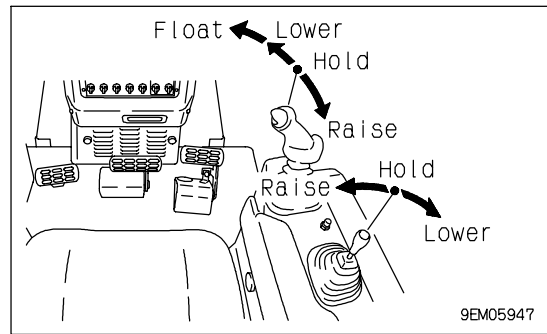

4. Check that the ripper is lowered to the ground.
5. Check that work equipment lock lever (4) is locked. If work equipment lock lever (4) is locked, the blade control lever is returned to the HOLD position even if it is in the FLOAT position.

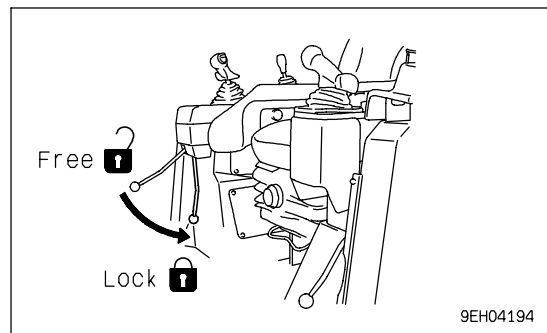

MACHINE OPERATION

MOVING MACHINE

WARNING

- Before moving the machine, check that the area around the machine is safe, and always sound the horn before moving.
Do not allow anyone to enter the area around the machine.
The rear of the machine is a blind spot, so be extremely careful when traveling in reverse.
- When moving the machine down a slope, always keep brake pedal (8) depressed, even after releasing parking brake lever (1).
- When moving the machine up a steep slope, turn fuel control dial (5) to high idling (MAX) position and run the engine at full speed, and keep brake pedal (8) and decelerator pedal (6) depressed. Then operate steering, directional, and gearshift lever (4) from the N (neutral) position to the direction of travel and slowly release brake pedal (8). When the travel speed rises, slowly release decelerator pedal (6).

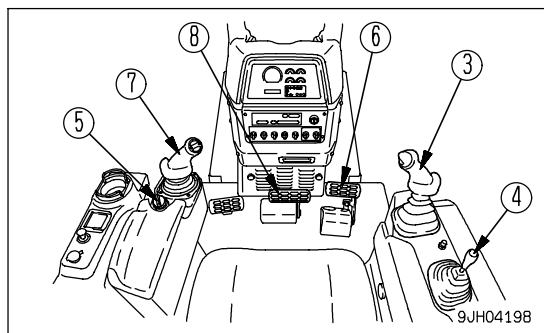
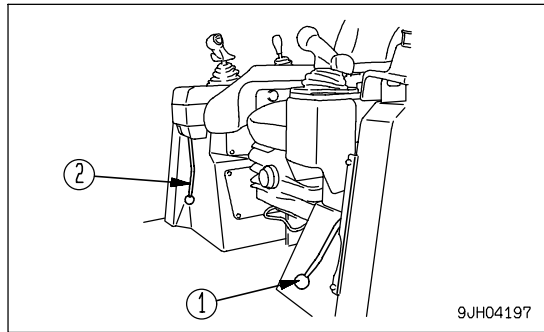

1. Set parking brake lever (1) to the FREE position.

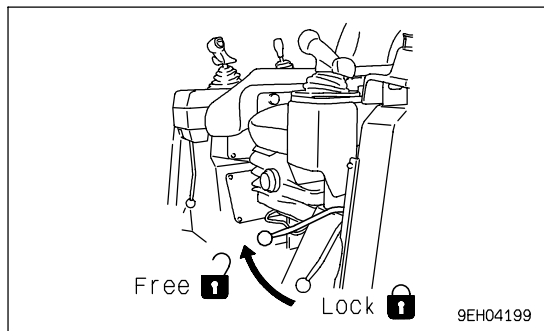

2. Set work equipment lock lever (2) for blade control lever (3) and ripper control lever (4) to the FREE position.

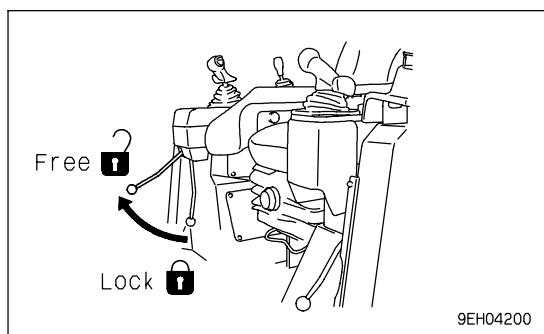

COUNTERROTATION TURNS TO LEFT WHEN TRAVELING FORWARD

NOTICE

When carrying out a counterrotation turn, if the load is not equal on the left and right sides, the machine may carry out a pivot turn, so check the ground conditions and be careful not to hit any obstacles.

With steering, forward-reverse, gear shift lever (1) in the N position, operate the lever partially to the left (L). The left and right tracks will rotate in opposite directions, and the machine will make a slow counterrotation turn. If the lever is moved further, the speed of the counterrotation turn will increase.

REMARK

When making a right counterrotation turn, move the steering, forward-reverse, gear shift lever (1) to the right (R) in the same way.

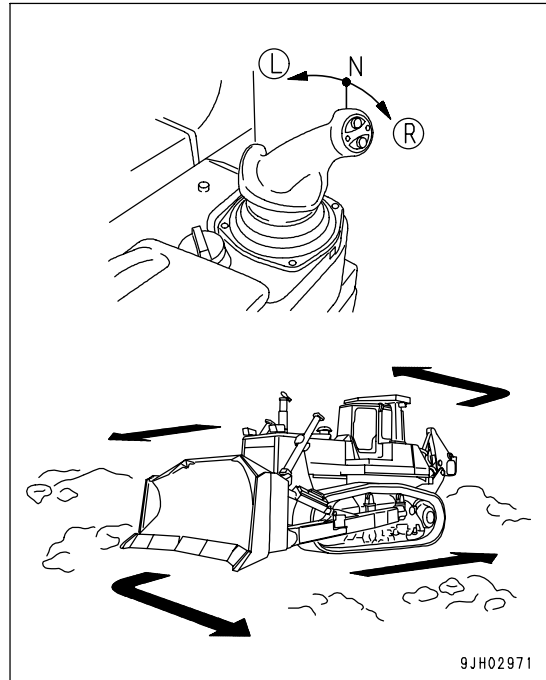

TURNING WHILE DESCENDING A SLOPE

TURNING GRADUALLY TO LEFT WHILE TRAVELING FORWARD

If steering, forward-reverse, gear shift lever (1) is moved to the FORWARD position (F) and moved partially to the left (L), the machine will start to turn gradually. After that, the lever can be moved further towards the end of its travel to set the desired turning radius.

REMARK

To turn gradually to the right while traveling forward, if the steering, forward-reverse, gear shift lever (1) is operated to the FORWARD position (F) and moved slowly to the right, the machine will start to turn gradually. After that, the lever can be moved further towards the end of its travel to set the desired turning radius.

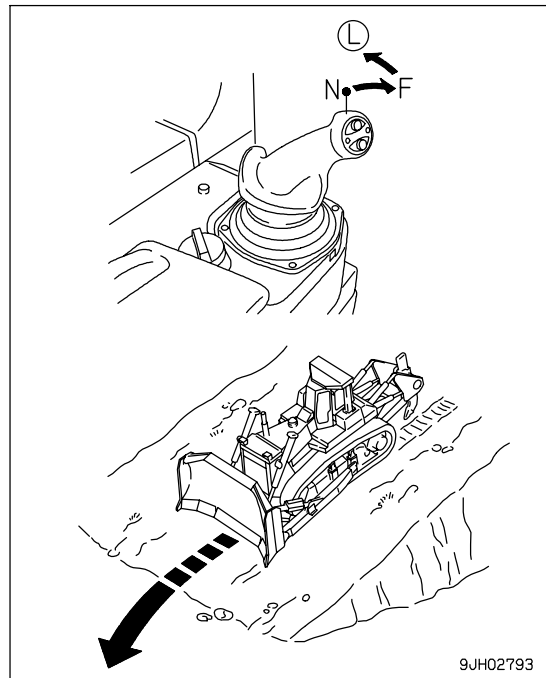

PARKING MACHINE

WARNING

- Avoid stopping suddenly. Give yourself ample room when stopping.
- When stopping the machine, select flat hard ground and avoid dangerous places. If it is unavoidably necessary to park the machine on a slope, place the parking brake lever (4) in the LOCK position and insert blocks underneath the track shoes. As an additional safety measure, thrust the blade into the ground.
- If the work equipment control lever is touched by accident, the work equipment may suddenly move, and may cause damage, serious injury, or death. Before leaving the operator's seat, always secure work equipment lock lever (7) in the LOCK position.

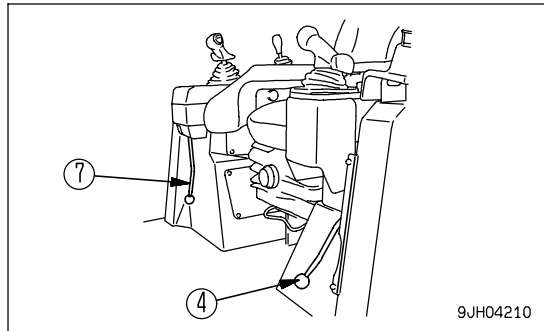
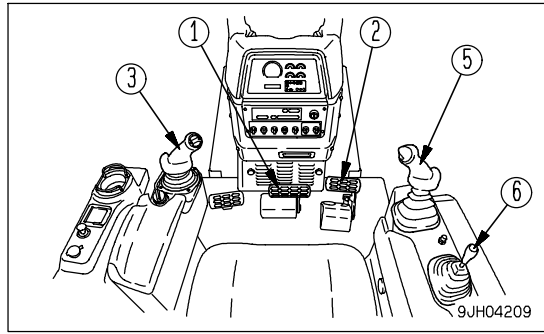

1. Depress brake pedal (1) to stop the machine.

NOTICE

If the brake pedal is depressed when the engine speed or machine travel speed is high, the brake disc may produce a slipping sound. When depressing the brake pedal, usually depress decelerator pedal (2) to reduce the engine speed and machine travel speed.

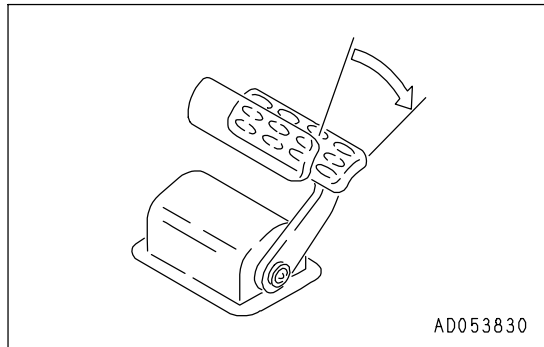

2. Place joystick (3) at the neutral position and set the speed range to 1st.

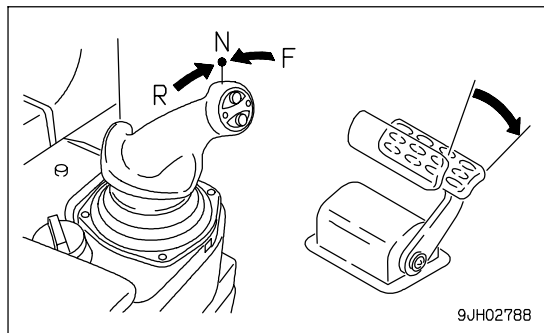

- 4) Secure the attachment at two places with a chain or wire rope.

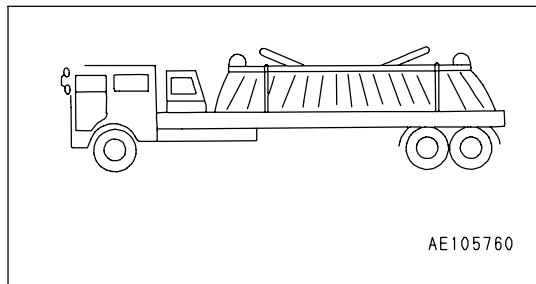

UNLOADING

1. Load and unload on firm level ground only. Maintain a safe distance from the edge of a road.
2. Properly apply the brakes on the trailer and put blocks under the tires to ensure that the trailer does not move. Make the slope of the ramps a maximum of 15°.
3. Remove the chains and wire ropes fastening the machine.

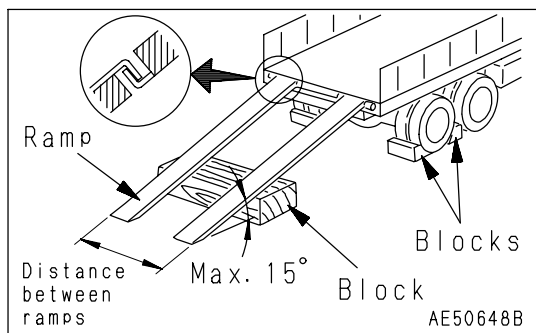

4. Start the engine.
Warm the engine up fully.
5. Set main work equipment lock lever to FREE position (F), and raise the work equipment.
(When transporting with work equipment installed)

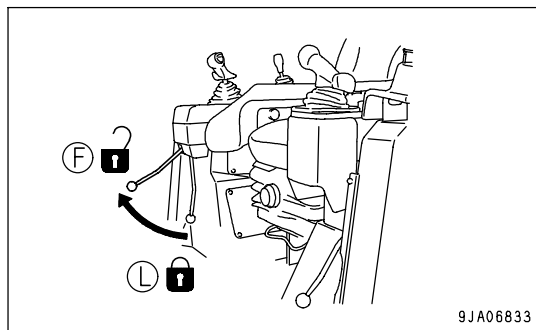

6. Set parking brake lever to the FREE position (F).
7. Set the transmission in the 1st gear and run the engine at low idle.
8. Set the travel direction toward the ramps and drive slowly.
9. The center of gravity of the machine shifts suddenly at the border between the ramps and trailer, and the machine is unbalanced and becomes dangerous. Accordingly, pass the border slowly.
10. Drive down the ramps slowly and carefully until the machine leaves the ramps perfectly.

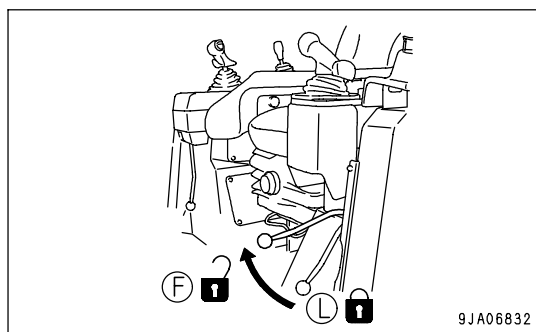

IF BATTERY IS DISCHARGED



WARNING

- It is dangerous to charge a battery when mounted on a machine. Make sure that it is dismantled before charging.
- When checking or handling the battery, stop the engine and turn the starting switch key to the OFF position.
- The battery generates hydrogen gas, so there is a hazard of explosion. Do not bring lighted cigarettes near the battery, or do anything that will cause sparks.
- Battery electrolyte is dilute sulfuric acid, and it will attack your clothes and skin. If it gets on your clothes or on your skin, immediately wash it off with a large amount of water. If it gets in your eyes, wash it out with fresh water and consult a doctor.
- When handling batteries, always wear safety glasses and rubber gloves.
- When removing the battery, first disconnect the cable from the ground (normally the negative (-) terminal). When installing, install the positive (+) terminal first.
If a tool touches the positive terminal and the chassis, there is danger that it will cause a spark, so be extremely careful.
- If the terminals are loose, there is danger that the defective contact may generate sparks that will cause an explosion.
- When removing or installing the terminals, check which is the positive (+) terminal and which is the negative (-) terminal.

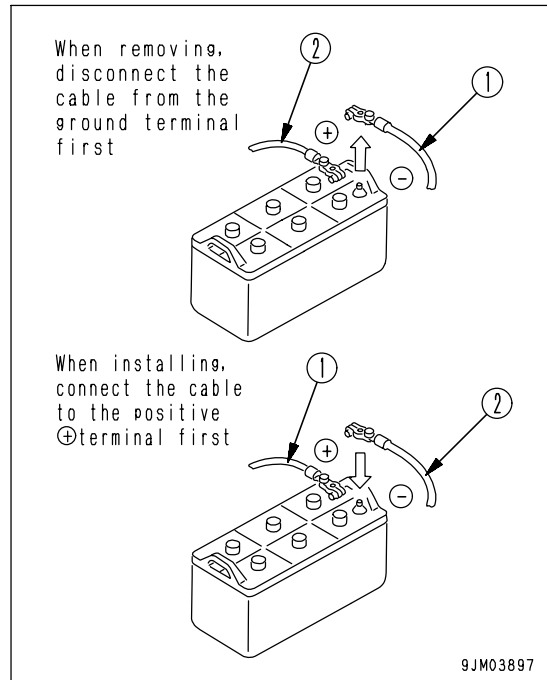

REMOVAL AND INSTALLATION OF BATTERY

- Before removing the battery, remove the ground cable (normally connected to the negative (-) terminal).
If any tool touches between the positive terminal and the chassis, there is a hazard of sparks being generated.
- When installing the battery, connect the ground cable last.
- When replacing the battery, secure it with battery hold-down.
Tightening torque: Tightening battery terminal: 9.8 to 14.7 Nm (1 to 1.5 kgm, 7.2 to 10.8 lbf)

REMOVAL, INSTALLATION OF BATTERY CABLE

1. Open the battery cover (1).
2. Before removing the battery, remove the ground cable (normally connected to the negative (-) terminal). If any tool touches between the positive terminal and the chassis, there is danger of sparks being generated. Loosen the nut of the terminal and remove the wires from the battery.
3. When installing the battery, connect the ground cable last.
Insert the hole of the terminal on the battery and tighten the nut.
Tightening torque: 9.8 to 19.6 Nm (1 to 2 kgm, 7.2 to 14.5 lbf)
4. Close the cover.

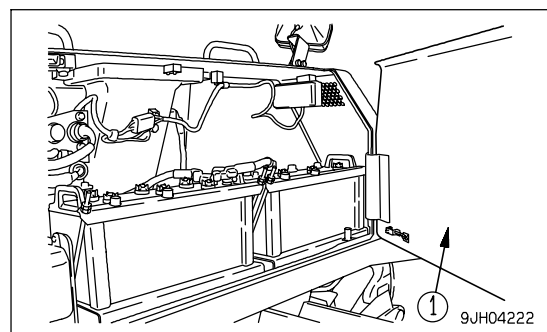

GUIDES TO MAINTENANCE

Do not perform any inspection and maintenance operation that is not found in this manual.
Stop the machine on flat hard ground when performing inspections and maintenance.

CHECK SERVICE METER:

Check the service meter reading every day to see if the time has come for any necessary maintenance to be performed.

KOMATSU GENUINE REPLACEMENT PARTS:

Use Komatsu genuine parts specified in the Parts Book as replacement parts.

KOMATSU GENUINE OILS:

For lubrication of the machine, use the Komatsu genuine lubricants. Moreover use oil of the specified viscosity according to the ambient temperature.

ALWAYS USE CLEAN WASHER FLUID:

Use automobile window washer fluid, and be careful not to let any dirt get into it.

CLEAN OIL AND GREASE:

Use clean oil and grease. Also, keep the containers of the oil and grease clean. Keep foreign materials away from oil and grease.

CHECK FOREIGN MATERIAL IN DRAINED OIL:

After oil is changed or filters are replaced, check the old oil and filters for metal particles and foreign materials. If large quantity of metal particles or foreign materials are found, always report to the person in charge, and carry out suitable action.

FUEL STRAINER:

If your machine is equipped with a fuel strainer, do not remove it while fueling.

WELDING INSTRUCTIONS:

- Turn off the engine starting switch.
- Do not apply more than 200 V continuously.
- Connect grounding cable within 1 m (3.3 ft) of the area to be welded. If grounding cable is connected near instruments, connectors, etc., the instruments may malfunction.
- If a seal or bearing happens to come between the part being welded and grounding point, change the grounding point to avoid such parts.
- Do not use the area around the work equipment pins or the hydraulic cylinders as the grounding point.

OBJECTS IN YOUR POCKETS:

- When opening inspection windows or the oil filler port of the tank to carry out inspection, be careful not to drop nuts, bolts, or tools inside the machine.
If such things are dropped inside the machine, it may cause damage and/or malfunction of the machine, and will lead to failure. If you drop anything inside the machine, always remove it immediately.
- Do not put unnecessary things in your pockets. Carry only things which are necessary for inspection.

		Engine oil pan	Damper case	Idler (each)	Power train oil pan (incl. transmission, torque converter and bevel gear cases)	Final drive case (each)	Hydraulic system	Fuel tank	Cooling system
Specified amount	liter	44	1.5	0.35	90	(EX)26 (PX)36	(EX)120 (PX)106	490	82
	US gal	11.62	0.40	0.09	23.78	(EX)6.87 (PX)9.51	(EX)31.70 (PX)28.01	129.46	21.66
Refill capacity	liter	38	1.5	0.35	60	(EX)26 (PX)36	71	-	-
	US gal	10.04	0.40	0.09	15.85	(EX)6.87 (PX)9.51	18.76	-	-

NOTICE

Always use diesel oil for the fuel.

To ensure good fuel consumption characteristics and exhaust gas characteristics, the engine mounted on this machine uses an electronically controlled high-pressure fuel injection device. This device requires high precision parts and lubrication, so if low viscosity fuel with low lubricating ability is used, the durability may drop markedly.

Note 1: HTHS (High-Temperature High-Shear Viscosity 150°C), specified by ASTM D4741 must be equal to or higher than 3.5 mPa-S. Komatsu EOS0W30 and EOS5W40 are the most suitable oils.

Note 2: Powertrain oil has different properties from engine oil. Be sure to use the recommended oils.

Note 3: Hyper grease (G2-T, G2-TE) has a high performance.

When it is necessary to improve the lubricating ability of the grease in order to prevent squeaking of pins and bushings, the use of G2-T or G2-TE is recommended.

Note 4: Supercoolant (AF-NAC)

1) Coolant has the important function of anticorrosion as well as antifreeze.

Even in the areas where freezing is not an issue, the use of antifreeze coolant is essential.

Komatsu machines are supplied with Komatsu Supercoolant (AF-NAC). Komatsu Supercoolant (AF-NAC) has excellent anticorrosion, antifreeze and cooling properties and can be used continuously for 2 years or 4000 hours. Komatsu Supercoolant (AF-NAC) is strongly recommended wherever available.

2) For details of the ratio when diluting super coolant with water, see "CLEAN INSIDE OF COOLING SYSTEM (PAGE 4-20)".

When the machine is shipped from the factory, it may be filled with coolant containing 30% or more Supercoolant (AF-NAC). In this case, no adjustment is needed for temperatures down to -10°C (14°F). (never dilute with water)

3) To maintain the anticorrosion properties of Supercoolant (AF-NAC), always keep the density of Supercoolant between 30% and 68%.

Note 5: In this range, preheating with a starting aid is necessary.

RECOMMENDED BRANDS, RECOMMENDED QUALITY FOR PRODUCTS OTHER THAN KOMATSU GENUINE OIL

When using commercially available oils other than Komatsu genuine oil, or when checking the latest specifications, refer to the Komatsu web page or consult your Komatsu distributor.

1. Stop the engine, wait for the coolant to cool completely, then turn valve (2) of corrosion resistor (1) to the Close stopper position.

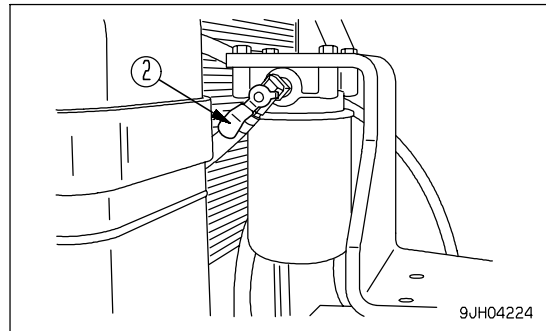
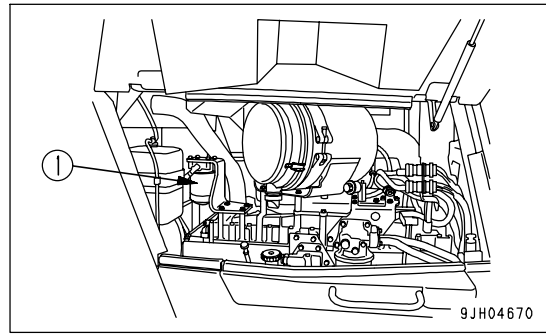

2. Turn main radiator cap (3) slowly, and remove.

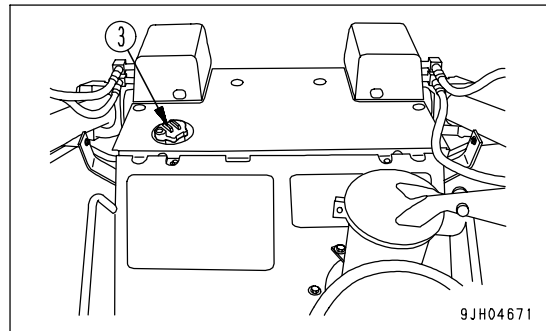

3. Prepare a container to catch the coolant, pull out hose (4) of the main radiator at the bottom front right of the machine, then open drain valve (5) and drain the water.
4. Open the drain valve (6) in the water pump piping on the right side of the engine, and drain the water.
5. After draining, close up drain valve (5), (6) and pour in clean water up to the vicinity of the water filler.
6. After the radiator is filled with water, start the engine and run it at low idle. After the water temperature rises above 90°C (194 °F), run the engine for approx. 10 minutes.
7. Stop the engine and open drain valve (5), (6) to drain the water.
8. After draining the water, clean the cooling system with cleaning agent.
For the cleaning method, see the instructions for the cleaning agent.

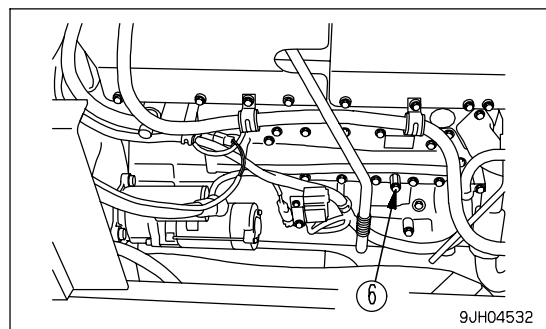
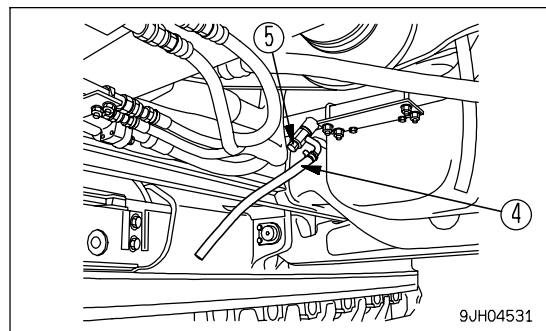

ADJUSTING IN VERTICAL DIRECTION

1. To determine the amount of adjustment, measure clearance B, then subtract 2 mm and record the result (amount of adjustment).

Example

If clearance B = 5 mm (0.197 in):

Amount of adjustment = 5 - 2 = 3 mm (0.118 in)

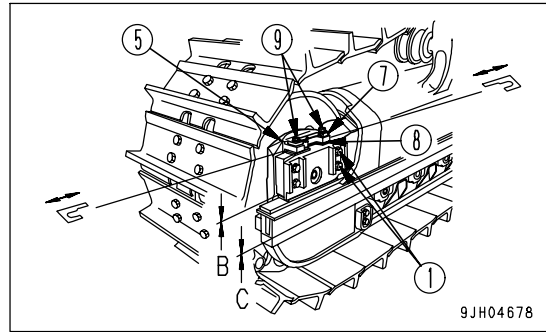

2. Loosen bolts (9) (inside, outside: Total 4) to a point where there is no more reaction from the spring.
3. Loosen bolt (1) (inside, outside: Total 8) . When doing this, do not loosen it more than 3 turns.
4. Using a bar, pull up up-down guide (5) to set clearance C to 0, then remove shims of a thickness equal to the amount of adjustment measured in Step 1.
5. After removing shims (7), add them on top of shim (8).

(Left, right, inside, outside: Total 8 places)

When doing this, check that the total thickness of shim (7) and shim (8) is the same after adjustment as it was before adjustment at all places.

Discarding shims or adding shims will result in improper function of the built-in spring.

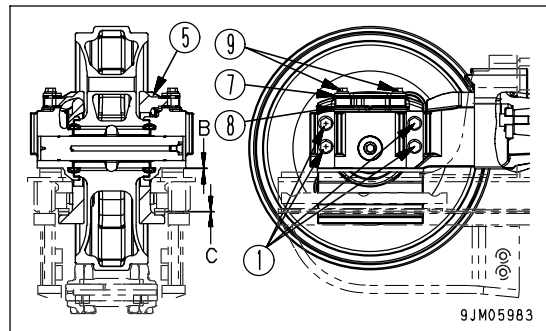

REMARK

There are two types of shim thickness: 1 mm (0.039 in) and 2 mm (0.079 in).

REPLACE WIPER BLADE

If the blade is damaged, it will not wipe the window clean, so replace the blade.

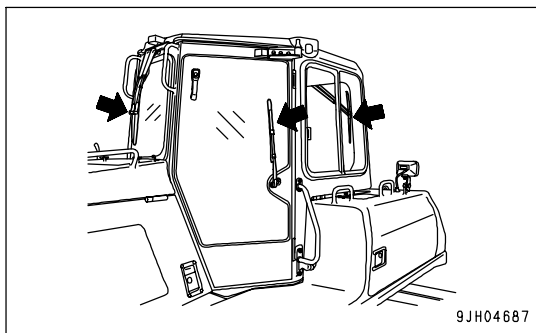

9JH04687

REPLACEMENT

FRONT, REAR WIPER

1. It is hooked at portion (A), so move the blade in the direction of the arrow to remove it.
2. Install the new blade and hook it securely.

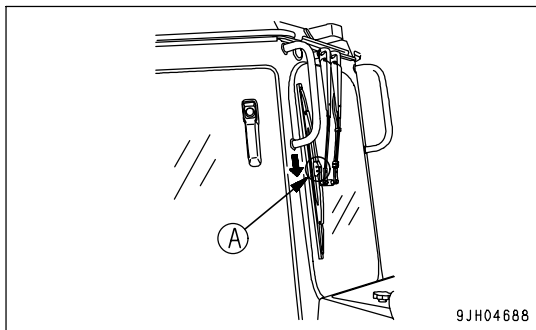

9JH04688

REAR WIPER

1. Remove E-ring (1).
The blade can then be removed.
2. Install a new blade, then install securely with E-ring (1).

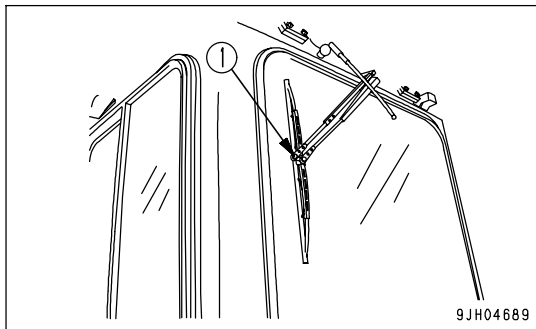

9JH04689

DOOR WIPER

1. It is hooked at portion (A), so move the blade in the direction of the arrow to remove it.
2. Install the new blade and hook it securely.

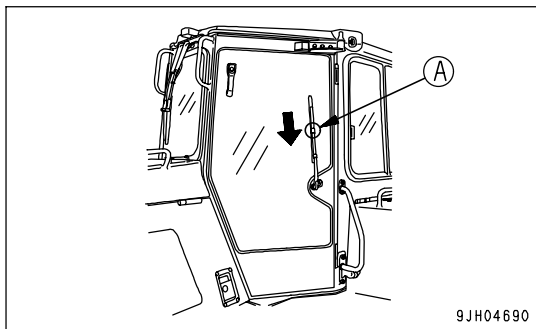

9JH04690

EVERY 500 HOURS SERVICE

Maintenance for every 250 hours should be performed at the same time.

CHANGE OIL IN ENGINE OIL PAN, REPLACE ENGINE OIL FILTER CARTRIDGE

(including engine by-pass filter cartridge)



WARNING

Parts and oil are at high temperature immediately after the engine is stopped and may cause serious burns. Wait for the oil temperature to go down before performing this operation.

- Refill capacity: 38 liters (10.04 US gal)
 - Prepare a socket wrench and filter wrench.
1. Remove the covers at the bottom left at the front of the machine and on the side face, and put a container directly underneath to catch the drained oil.
 2. Loosen drain plug (P) (with a slit) slowly to avoid getting oil on yourself, and drain the oil.
 3. Check the drained oil, if there is excessive metal particles or foreign material, contact your Komatsu distributor.
 4. Install drain plug (P).
 5. Using a filter wrench, turn filter cartridge (1) counterclockwise to remove it.
 6. Clean the filter holder, fill the new filter cartridge with clean oil, coat the thread and packing portion of the new filter cartridge with oil (or coat thinly with grease), then install.
 7. When installing the filter cartridge, bring the packing surface into contact with the filter holder, then tighten a further 3/4 to 1 turn.
 8. After replacing the filter cartridge, add oil through oil filler (F) until the oil level is between the H and L marks on the dipstick (G).
 9. Run the engine at idling for a short time, then stop the engine, and check that the oil level is between the H and L marks on the dipstick. For details, see "CHECK OIL LEVEL IN ENGINE OIL PAN, ADD OIL (PAGE 3-78)".

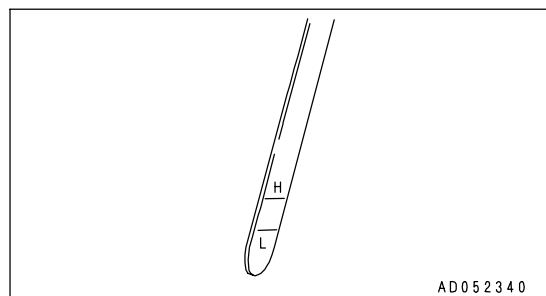
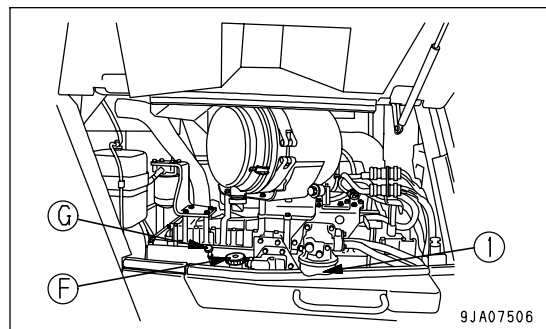
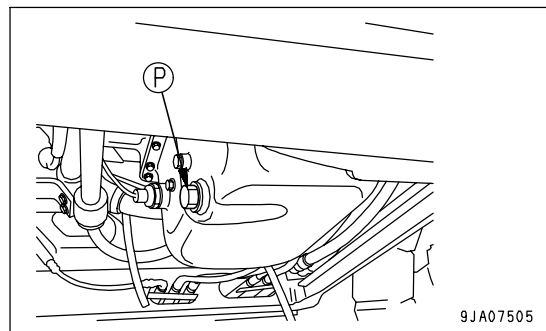

REPLACE CORROSION RESISTOR CARTRIDGE

**WARNING**

If the engine has been operated, all parts will be at a high temperature, so never try to replace the cartridge immediately after stopping the engine.

Always wait for the engine and other parts to cool down.

- Container to catch drained coolant
 - Prepare a filter wrench for fuel filter element.
1. Turn valve (2) of corrosion resistor (1) as far as the CLOSE stopper.
 2. Set a container to catch the coolant under the cartridge.
 3. Using a filter wrench, turn cartridge (3) to the left to remove it.
 4. Clean the filter holder, coat the packing surface and thread of the new cartridge with oil, then install it to the filter holder.
 5. When installing, tighten until the packing surface contacts the seal surface of the filter holder, then tighten it up 2/3 of a turn. If the filter cartridge is tightened too far, the packing will be damaged and this will lead to leakage of coolant. If the filter cartridge is too loose, coolant will also leak from the packing, so always tighten to the correct amount.
 6. Turn valve (2) of the cartridge to the OPEN position.
 7. After replacing the cartridge, start the engine and check for any coolant leakage from the filter seal surface. If there is any leakage, check if the cartridge is tightened properly.

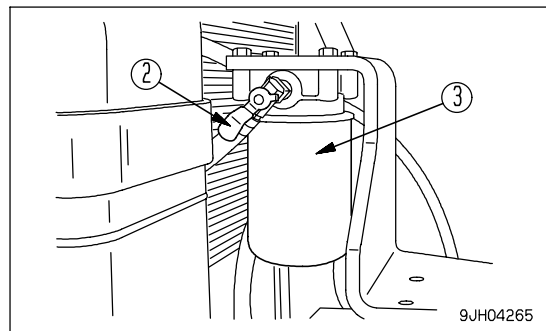
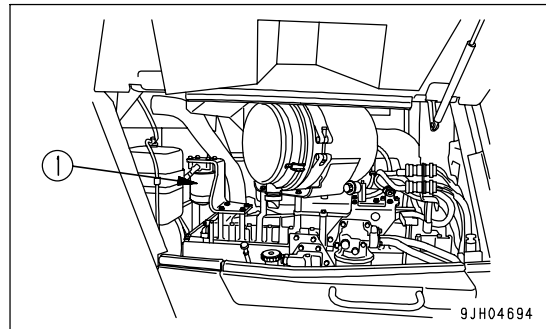

CHECKING FOR MISSING FUEL SPRAY PREVENTION CAP, HARDENING OF RUBBER

Fuel spray prevention caps (1) - (16) and fuel spray prevention cover (17) are protective parts installed to prevent fire caused by fuel leaking and spraying out on to high temperature parts of the engine. Check visually that there are no missing caps or loose bolts, and feel with your finger to check that the rubber has not hardened. If there is any problem, the problem part must be replaced. Contact your Komatsu distributor for part replacement.

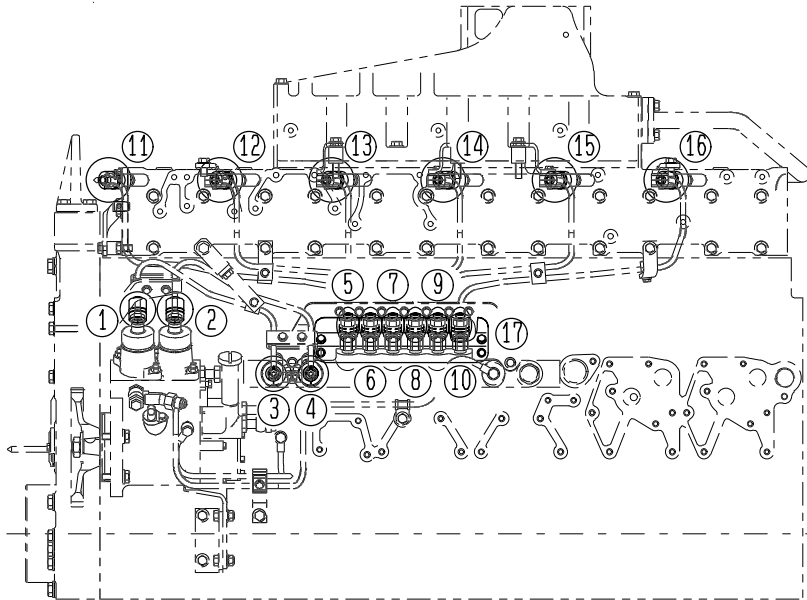

9JH01926

EXPLANATION OF COMPONENTS

The following is an explanation of devices needed for operating the machine.

To perform suitable operations correctly and safely, it is important to completely understand methods of operating the equipment, and the meanings of the displays.

CONTROL LEVERS AND PEDALS

WORK EQUIPMENT LOCK LEVER



WARNING

When standing up from the operator's seat, lower the blade to the ground and set the work equipment lock lever securely to the LOCK position. If the work equipment is not locked securely, there is danger of serious injury if the blade control lever is touched by mistake.

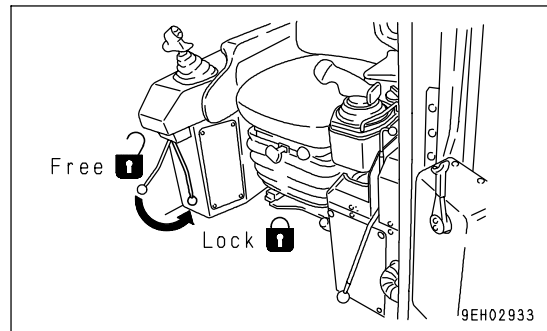

The work equipment lock lever is a device to lock the blade control lever. If it is set to the LOCK position, operations of the trimming dozer are locked.

REMARK

When starting the engine, to ensure safety, always set the work equipment lock lever to the LOCK position.

BLADE CONTROL LEVER

Use the blade control lever to operate the trimming dozer.

- (a) RAISE:
- (b) HOLD: Blade is stopped and held in this position.
- (c) LOWER:
- (d) FLOAT: Blade will move freely according to external force.
- (A) Tilted forward: Blade is tilted forward
- (B) Tilted back: Blade is tilted back

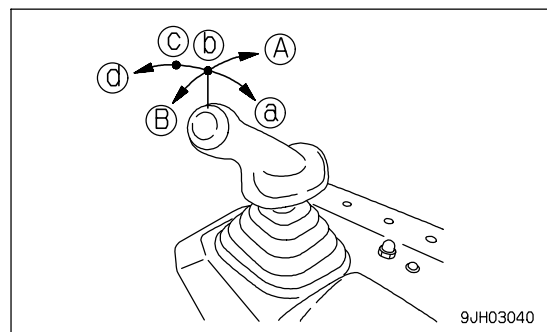

CAUTION

- Do not use this machine for dozing operations or digging operations.
- Do not operate the machine in forward or reverse with the machine jacked up by the blade.

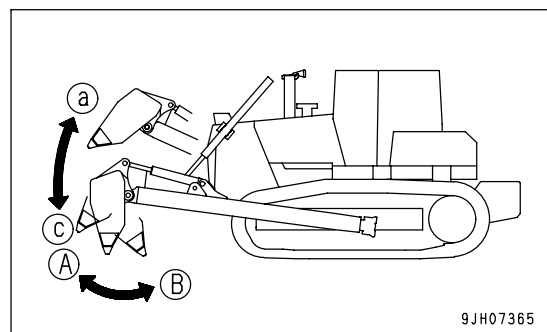

CLICK HERE TO **DOWNLOAD** THE COMPLETE MANUAL

- Thank you very much for reading the preview of the manual.
- You can download the complete manual from: www.heydownloads.com by clicking the link below



- Please note: If there is no response to CLICKING the link, please download this PDF first and then click on it.

CLICK HERE TO **DOWNLOAD** THE COMPLETE MANUAL